

THE INFORMATION CONTAINED HEREIN IS CONSIDERED "PROPRIETARY" TO BEL FUSE INC. AND SHALL NOT BE COPIED, REPRODUCED OR DISCLOSED WITHOUT THE WRITTEN APPROVAL OF BEL FUSE INC.

RoHS



ELECTRICAL CHARACTERISTICS @ 25°C
TURNS RATIO

TP1	1CT : 1CT	±2%
TP2	1CT : 1CT	±2%
TP3	1CT : 1CT	±2%
TP4	1CT : 1CT	±2%

QCL @ 100kHz/100mVRMS
FOR CHANNEL 1 AND CHANNEL 2
11mA DC BIAS 350μH MIN.
Compliant to IEEE 802.3at specification
FOR CHANNEL 3 AND CHANNEL 4
8mA DC BIAS 350μH MIN.
INS. LOSS

0.1MHz TO 1MHz	-1.1 dB MAX
1MHz TO 65MHz	-0.5 dB MAX
65MHz TO 100MHz	-0.8 dB MAX
100MHz TO 125MHz	-1.2 dB MAX

RET. LOSS (MIN) @ 100OHMS ±15%

0.5MHz-40MHz	-18 dB
40MHz-100MHz	-12+20LOG(f/80MHz) dB

CM TO CM REJ
100kHz - 100MHz -30 dB MIN

CM TO DM REJ
100kHz - 100MHz -35 dB MIN

HIPOT (Isolation Voltage): 2250 VDC
100% OF PRODUCTION TESTED TO COMPLY WITH
IEEE 802.3 ISOLATION REQUIREMENTS.

BALANCED DC LINE CURRENT 600mA MAX. CONTINUOUS
LED 1 & 2 & 3 & 4 1.2A MAX. FOR 200 MILLISECONDS

VF (FORWARD VOLTAGE)	IF=20mA	GREEN	2.2V TYP.
		YELLOW	2.1V TYP.
λD (DOMINANT WAVELENGTH)	IF=20mA	GREEN	570nm TYP.
		YELLOW	590nm TYP.

OPERATING TEMPERATURE -40°C TO +85°C

LED 2 & 4 POLARITY			LED 1 & 3 POLARITY		
PIN 13	PIN 14	COLOR	PIN 15	PIN 16	COLOR
+	-	YELLOW	+	-	YELLOW
-	+	GREEN	-	+	GREEN

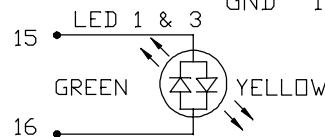
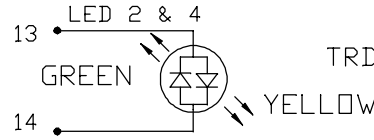

SCHEMATIC

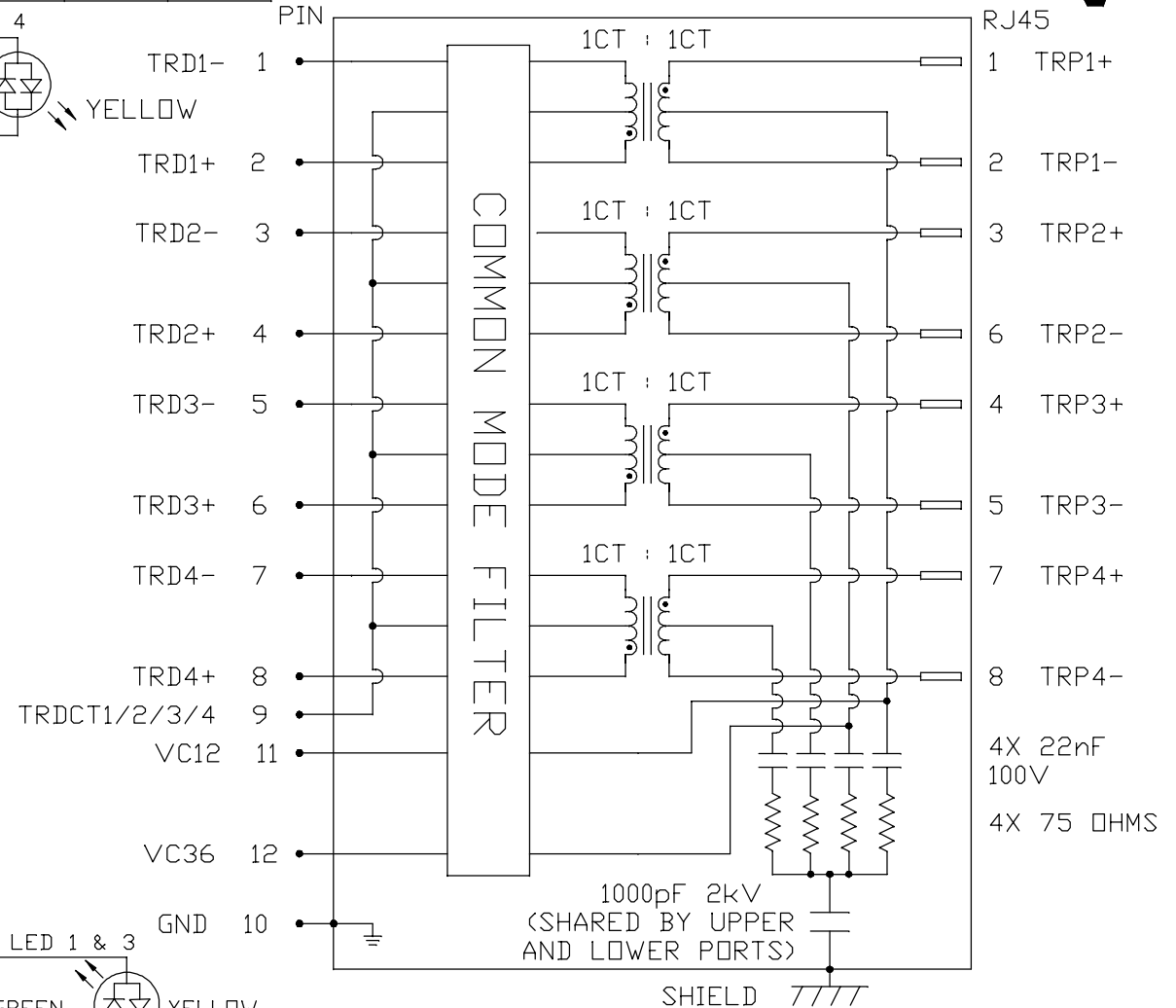

ORIGINATED BY
CHOW WANCHUNG
DATE 2019-10-16

TITLE
2X6 gigabit MagJack®
PoEp
(WITH EXTENDED TEMPERATURE)
PATENTED

PART NO. / DRAWING NO.
0895-2C6R-GK

FILE NAME
0895-2C6R-GK_B.DWG

STANDARD DIM. TOL. IN INCH	[] METRIC DIM. AS REF.
.X	UNIT : INCH [mm]
.XX	SCALE : N/A
.XXX	SIZE : A4

REV. : B PAGE : 2

a bel group

THE INFORMATION CONTAINED HEREIN IS CONSIDERED "PROPRIETARY" TO BEL FUSE INC. AND SHALL NOT BE COPIED, REPRODUCED OR DISCLOSED WITHOUT THE WRITTEN APPROVAL OF BEL FUSE INC.

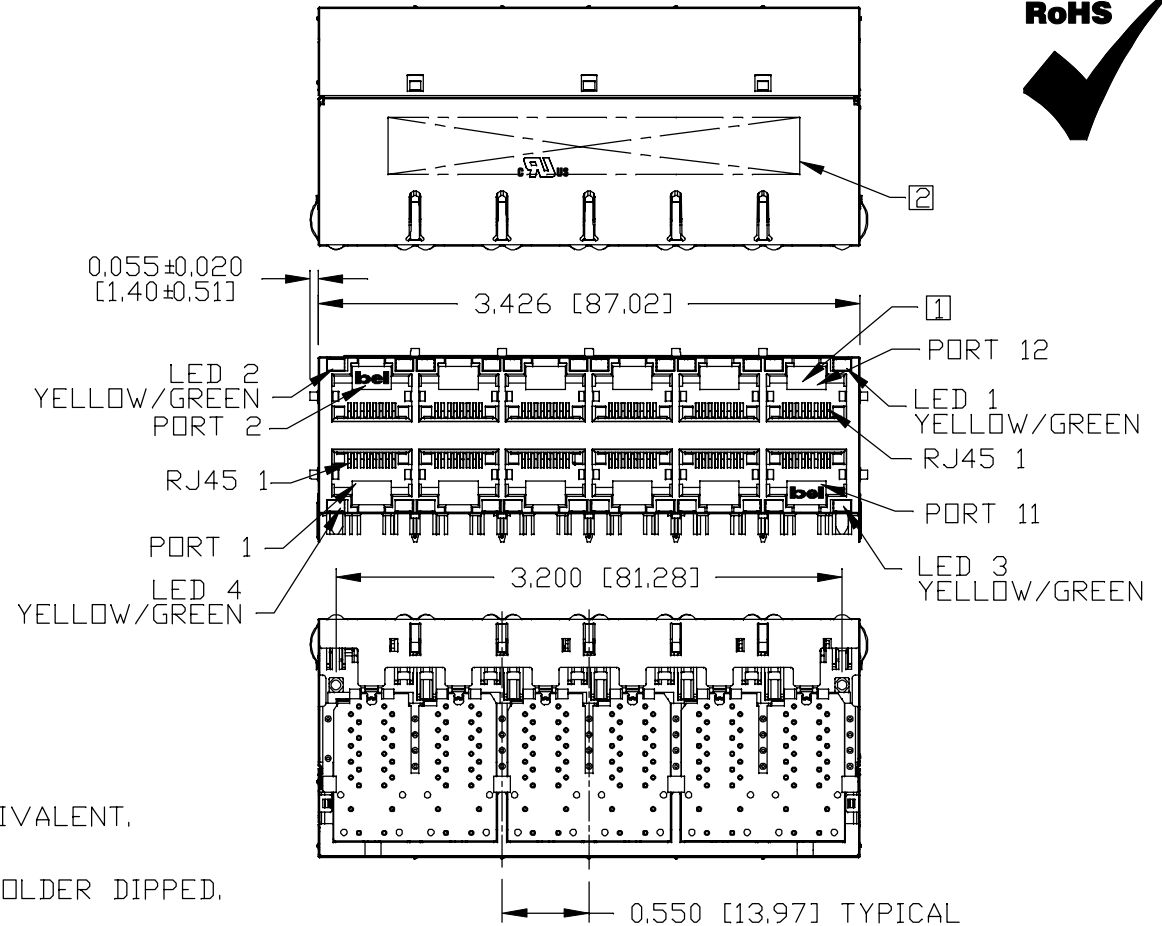
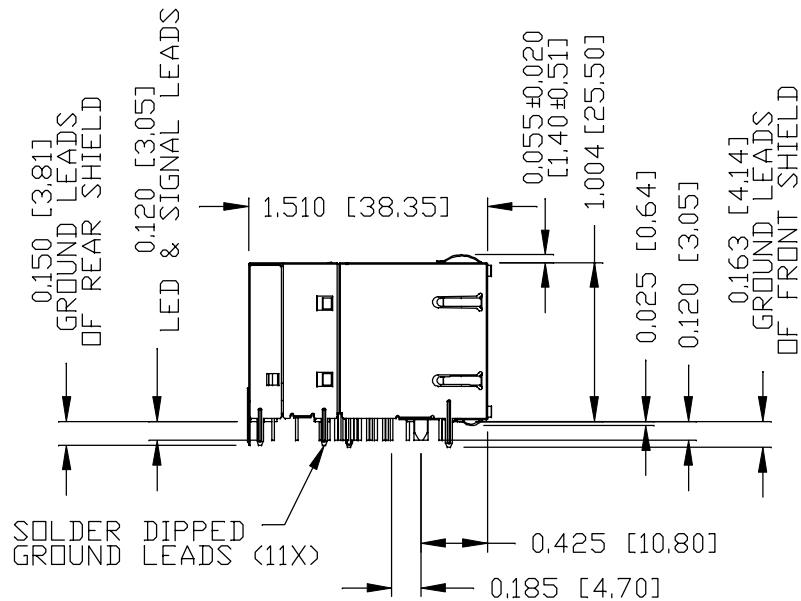

NOTES:

- PLASTIC HOUSING: THERMOPLASTIC PBT, BLACK
 FLAMMABILITY RATING UL 94V-0
- CONTACT PLATING: 50 MICRO-INCH HARD GOLD PLATING OR EQUIVALENT.
- OUTPUT PINS: TIN-COATED COPPER WIRE, DIA 0.018 INCH.
 100 MICRO-INCH MIN MATTE TIN. PINS ARE SOLDER DIPPED.
- METAL SHIELD: NICKEL PLATED ON COPPER ALLOY.
 (ALL GROUND LEADS ARE SOLDER DIPPED)

- 1. JACK CAVITY CONFORMS TO FCC RULES AND REGULATIONS, PART 68 SUBPART F.
- 2. MARK PART WITH MFG LOGO, MFG NAME, PART NUMBER, DATE CODE AND PATENTED.
- 3. THE PRODUCT IS RoHS COMPLIANT.

- 4. THE PRODUCT IS PATENTED. THE PATENT NUMBER ARE U.S. PAT. 6,840,817 AND U.S. PAT. 7,123,117.
- 5. REVERSED POLARITY OF GENERAL 'C' LED.
- 6. THE PART IS RECOMMENDED FOR WAVE SOLDERING. THE SUGGESTED PEAK WAVE SOLDERING CONDITION IS 260°C MAX AND 10 SECONDS MAX.

UL UL RECOGNIZED - FILE #E196366 AND E169987.

REV. : B PAGE : 3

ORIGINATED BY SANDY LIN DATE 2019-10-16	TITLE 2X6 gigabit MagJack® PoEp (WITH EXTENDED TEMPERATURE) PATENTED	PART NO. / DRAWING NO. 0895-2C6R-GK	STANDARD DIM. TOL. IN INCH	[] METRIC DIM. AS REF.
		FILE NAME 0895-2C6R-GK_B.DWG	.X	UNIT : INCH [mm]
			.XX	SCALE : N/A
DRAWN BY RUAN WENJUN DATE 2019-10-16			.XXX	±0.010



THE INFORMATION CONTAINED HEREIN IS CONSIDERED "PROPRIETARY" TO BEL FUSE INC. AND SHALL NOT BE COPIED, REPRODUCED OR DISCLOSED WITHOUT THE WRITTEN APPROVAL OF BEL FUSE INC.

RoHS



PORT ASSIGNMENT
(COMPONENT SIDE VIEW)

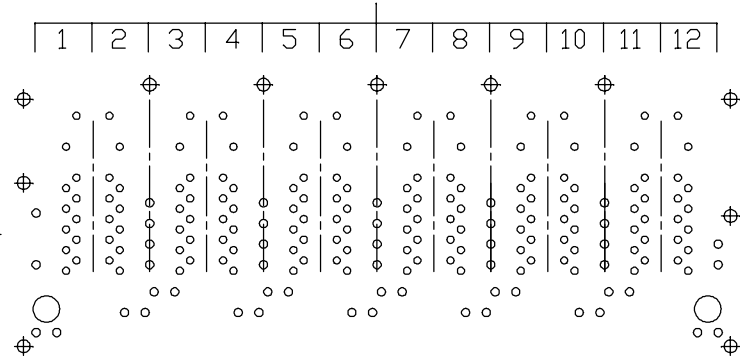
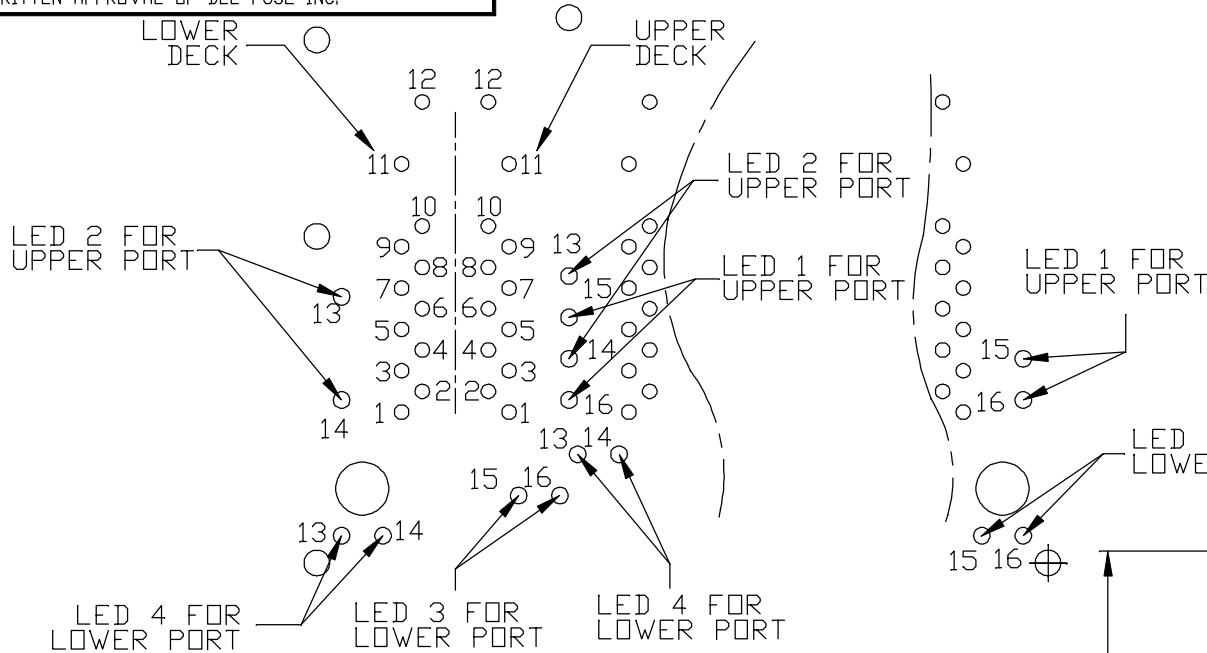

PIN-OUT INFORMATION
(COMPONENT SIDE VIEW)

12	VC36		
11	VC12		
10	GND		
9	TRDCT1/2/3/4		
8	TRD 4+		
7	TRD 4-		
6	TRD 3+		
5	TRD 3-		
4	TRD 2+	16	YEL(-) GRN(+)
3	TRD 2-	15	YEL(+) GRN(-)
2	TRD 1+	14	YEL(-) GRN(+)
1	TRD 1-	13	YEL(+) GRN(-)

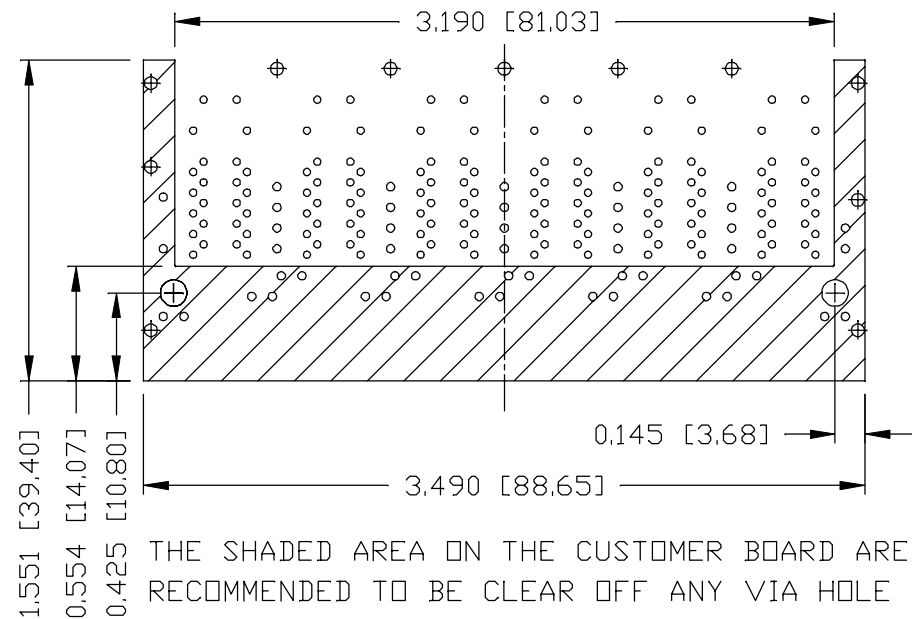

THE SHADED AREA ON THE CUSTOMER BOARD ARE RECOMMENDED TO BE CLEAR OFF ANY VIA HOLE OR COMPONENT PAD.

REV. : B PAGE : 4

ORIGINATED BY
SANDY LIN
DATE 2019-10-16

DRAWN BY
RUAN WENJUN
DATE 2019-10-16

TITLE
2X6 gigabit MagJack®
PoEp
(WITH EXTENDED TEMPERATURE)
PATENTED

PART NO. / DRAWING NO.
0895-2C6R-GK

FILE NAME
0895-2C6R-GK_B.DWG

STANDARD DIM. [] METRIC DIM.
TOL. IN INCH AS REF.
.X UNIT : INCH [mm]
.XX SCALE : N/A
.XXX ±0.004 SIZE : A4



THE INFORMATION CONTAINED HEREIN IS CONSIDERED "PROPRIETARY" TO BEL FUSE INC. AND SHALL NOT BE COPIED, REPRODUCED OR DISCLOSED WITHOUT THE WRITTEN APPROVAL OF BEL FUSE INC.

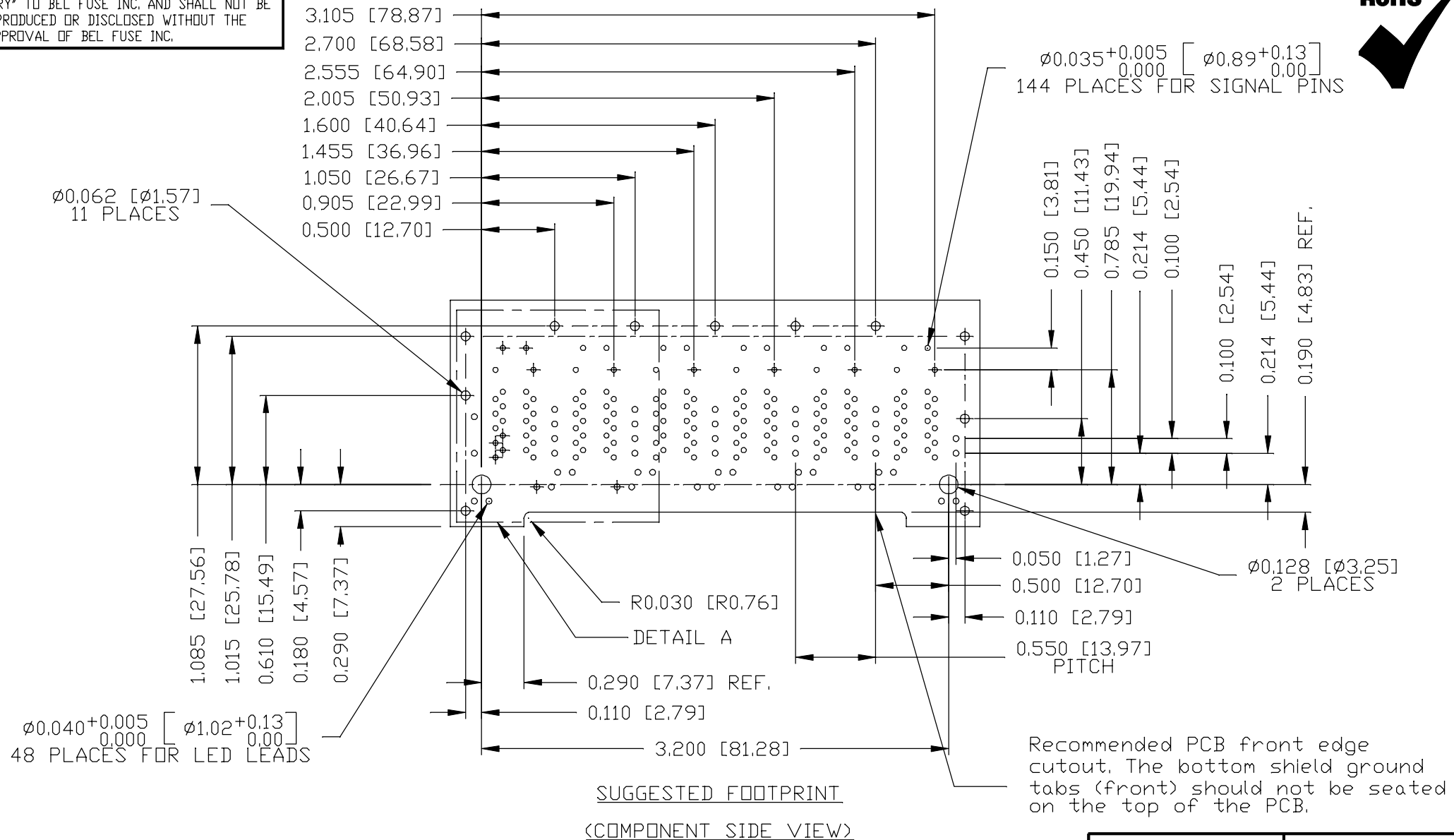

SUGGESTED FOOTPRINT
(COMPONENT SIDE VIEW)

REV. : B PAGE : 5

ORIGINATED BY
SANDY LIN
DATE 2019-10-16
DRAWN BY
RUAN WENJUN
DATE 2019-10-16

TITLE
2X6 gigabit MagJack®
PoEp
(WITH EXTENDED TEMPERATURE)
PATENTED

PART NO. / DRAWING NO.
0895-2C6R-GK
FILE NAME
0895-2C6R-GK_B.DWG

STANDARD DIM. TOL. IN INCH	[] METRIC DIM. AS REF.
.X	UNIT : INCH [mm]
.XX	SCALE : N/A
.XXX	±0.004
	SIZE : A4



THE INFORMATION CONTAINED HEREIN IS CONSIDERED "PROPRIETARY" TO BEL FUSE INC. AND SHALL NOT BE COPIED, REPRODUCED OR DISCLOSED WITHOUT THE WRITTEN APPROVAL OF BEL FUSE INC.

RoHS

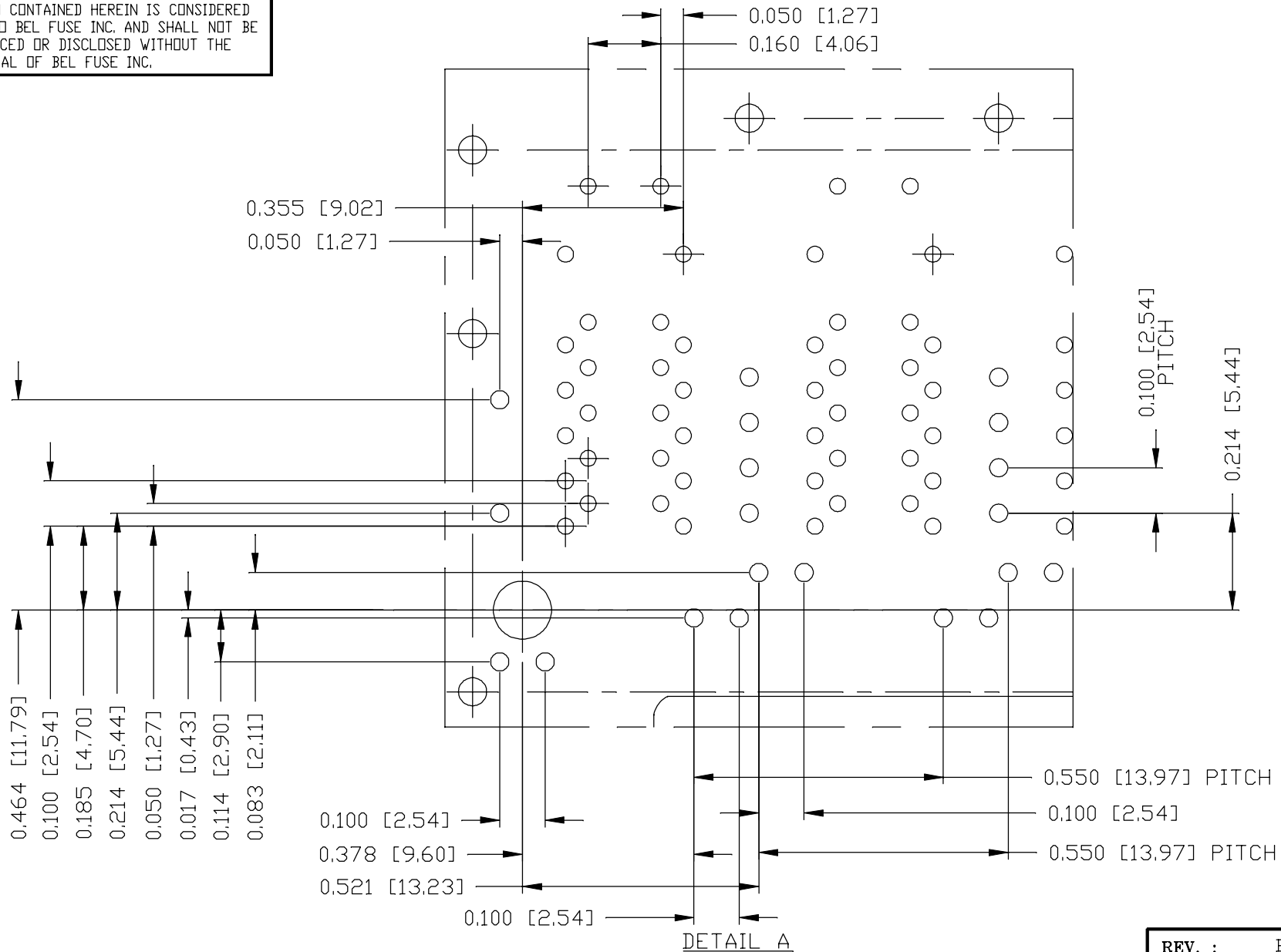

DETAIL A

REV. :	B	PAGE :	6
--------	---	--------	---

ORIGINATED BY
SANDY LIN
DATE 2019-10-16

DRAWN BY
RUAN WENJUN
DATE 2019-10-16

TITLE
2X6 gigabit MagJack®
PoEp
(WITH EXTENDED TEMPERATURE)
PATENTED

PART NO. / DRAWING NO.
0895-2C6R-GK

FILE NAME
0895-2C6R-GK_B.DWG

STANDARD DIM. TOL. IN INCH	[] METRIC DIM. AS REF.
.X	UNIT : INCH [mm]
.XX	SCALE : N/A
.XXX	±0.004
	SIZE : A4



THE INFORMATION CONTAINED HEREIN IS CONSIDERED "PROPRIETARY" TO BEL FUSE INC. AND SHALL NOT BE COPIED, REPRODUCED OR DISCLOSED WITHOUT THE WRITTEN APPROVAL OF BEL FUSE INC.

RoHS



SUGGESTED PANEL OPENING

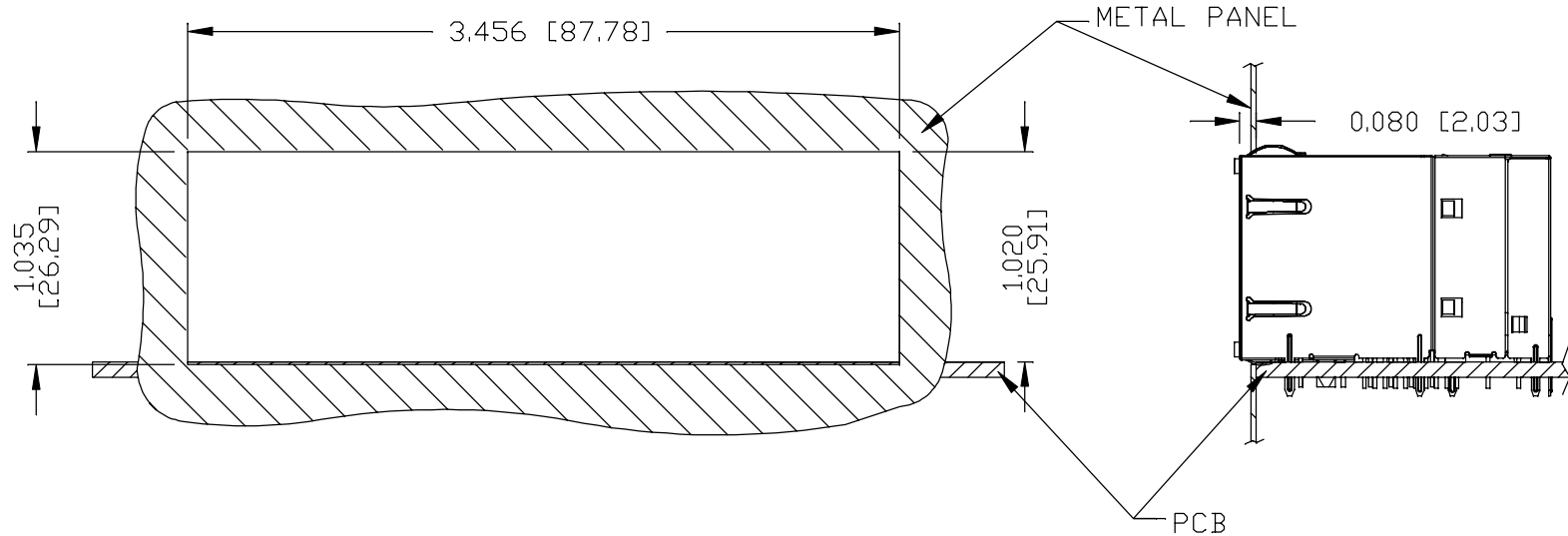

NOTE:

THE DISTANCE OF PANEL INSIDE SURFACE RELATIVE TO FRONT SURFACE OF PART IS ONLY A SUGGESTION. IN CASE THIS DISTANCE IS DIFFERENT, THE REQUIRED PANEL OPENING DIMENSIONS CHANGE ACCORDINGLY.

PACKING INFORMATION

PACKING TRAY : 0200-9999-B7 (TOP)

0200-9999-B8 (BOTTOM)

PACKING QUANTITY : 15 PCS FINISHED GOODS PER TRAY.

5 TRAYS (75 PCS FINISHED GOODS) PER CARTON BOX.

NOTE : CARDBOARDS ARE PLACED BETWEEN LAYERS OF PACKING TRAY INSIDE CARTON BOX.
(INCLUDE THE UPPERMOST AND LOWERMOST TRAY)

REV. :	B	PAGE :	7
--------	---	--------	---

ORIGINATED BY SANDY LIN DATE 2019-10-16 DRAWN BY RUAN WENJUN DATE 2019-10-16	TITLE 2X6 gigabit MagJack® PoEp (WITH EXTENDED TEMPERATURE) PATENTED	PART NO. / DRAWING NO. 0895-2C6R-GK FILE NAME 0895-2C6R-GK_B.DWG	STANDARD DIM. TOL. IN INCH	[] METRIC DIM. AS REF.
			.X	UNIT : INCH [mm]
			.XX	SCALE : N/A
		.XXX ±0.005	⊕ □	SIZE : A4

