

ISO METRIC VIEW

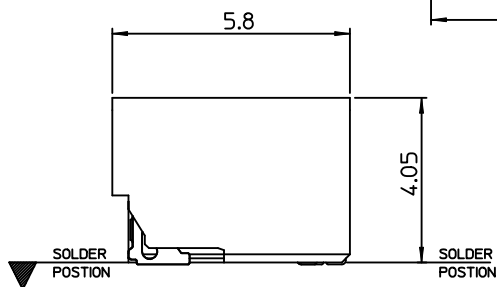

RECOMMEND PATTERN [REF.]

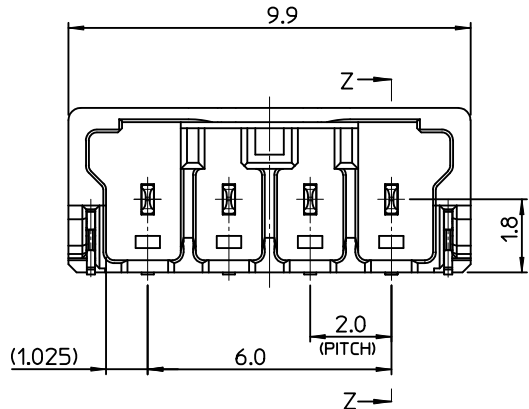
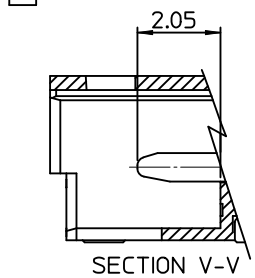
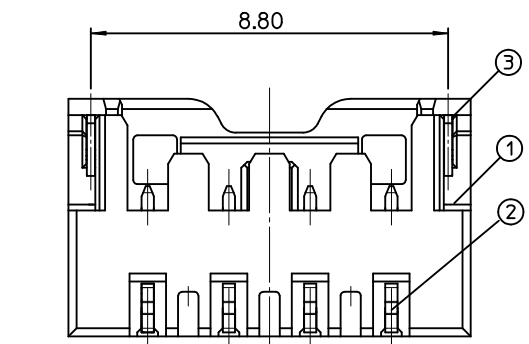
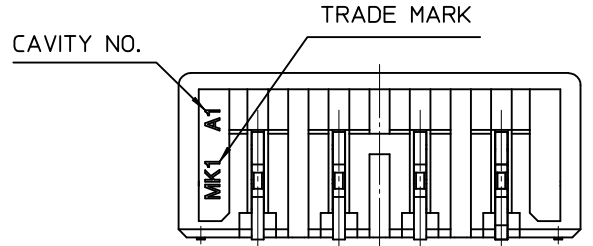

SECTION V-V

NOTES.

- MATED WITH : 104047-0490
- MATERIALS
 HEADER : LCP, GLASS FILLED, UL94V-0
 COLOR OF NATURAL
 CONTACT TERMINAL : POSPHOR BRONZE
 FITTING NAIL : PHOSPHOR BRONZE

3. FINISHES

- CONTACT TERMINAL : PURE-TIN PLATING ON OVERALL.
 THICKNESS 3.0µm~5.0µm
 UNDER PLATING Ni OVERALL.
 THICKNESS 1.25µm~3.75µm
- FITTING NAIL : PURE-TIN PLATING ON OVERALL.
 THICKNESS 3.0µm~5.0µm
 UNDER PLATING Ni OVERALL.
 THICKNESS 1.25µm~3.75µm

- PRODUCT SPECIFICATION No. : PS-104046-001
- PACKAGING SPECIFICATION No. : PK-104046-001

3	FITTING NAIL	104465-8002	4
2	CONTACT TERMINAL	104464-8002	
1	HEADER	104046-0490	
NO	PART NAME	MATERIAL NO.	CKT

REVISED	EC NO: KOR2010-0143	2010/03/23	QUALITY SYMBOLS
	DRW: JHPARK01	2010/03/25	
B	CHK: WYANG	2010/03/25	DESCRIPTION
	APPR: YUNSIKKIM	2010/03/25	

QUALITY SYMBOLS	▽=0	▽C=0
	DRAFT WHERE APPLICABLE MUST REMAIN WITHIN DIMENSIONS	

GENERAL TOLERANCES (UNLESS SPECIFIED)		DIMENSION STYLE MM ONLY	
	mm	INCH	
4 PLACES	± ---	± ---	DRAWN BY SK.HAN
3 PLACES	± ---	± ---	DATE 2009/03/11
2 PLACES	± 0.20	± ---	CHECKED BY WY.YANG
1 PLACE	± 0.25	± ---	DATE 2009/03/11
ANGULAR ± 3 °		APPROVED BY WY.YANG	
		DATE 2009/03/11	
		MATERIAL NO. 1040460417	

SCALE 8:1	DESIGN UNITS METRIC	THIRD ANGLE PROJECTION
TITLE 2.0 W-T-B CONN. HEADER ASS'Y-4P		
MOLEX INCORPORATED		SHEET NO. 1 OF 01
DOCUMENT NO. SD-104046-001		
THIS DRAWING CONTAINS INFORMATION THAT IS PROPRIETARY TO MOLEX INCORPORATED AND SHOULD NOT BE USED WITHOUT WRITTEN PERMISSION		

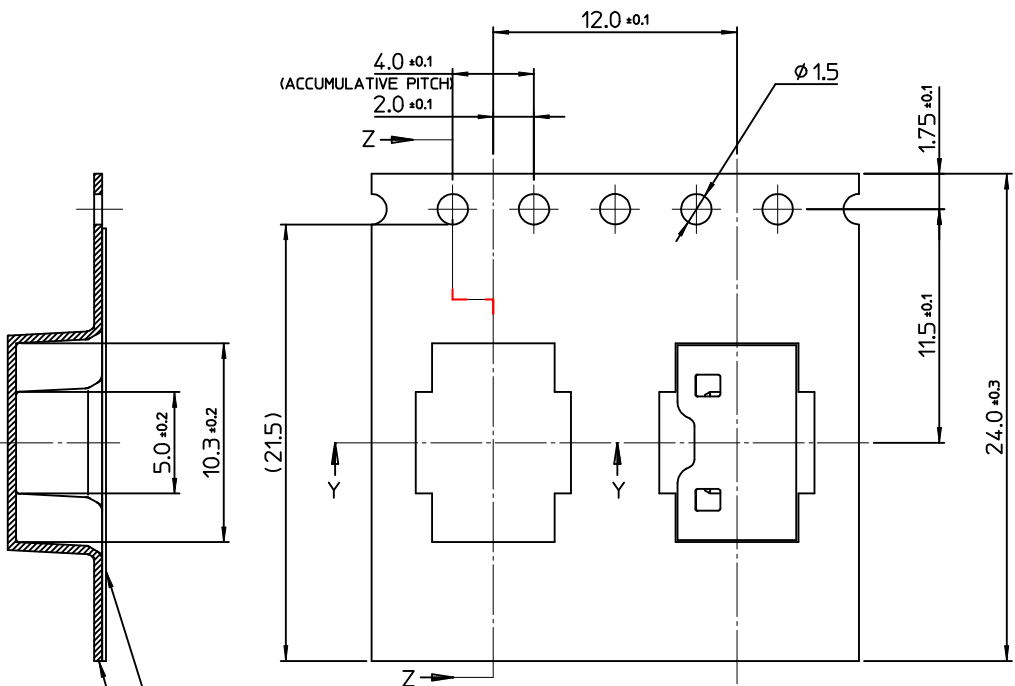

SECTION Z-Z

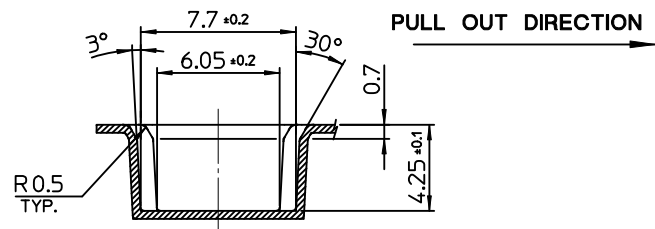

SECTION Y-Y

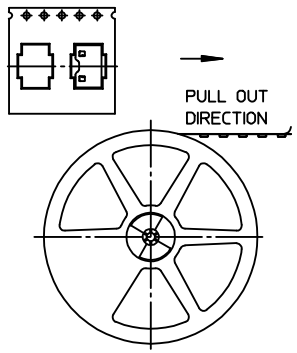

PLASTIC BOBBIN

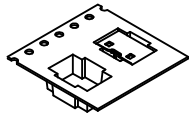

NOTES

1. QUANTITY OF CONNECTORS : 1500 PCS/REEL
2. LEAD LENGTH
3. PEELING OFF FORCE OF COVER TAPE : 0.1N~0.59N(10.2GF~60GF)
 (PEELING DIRECTION AS SHOW IN FOLLOW FIG.)
 PEELING OFF SPEED : 300mm/Min.(Ref.)
4. FLASH IN ANY PORTION SHOULD BE LESS THAN 0.20mm MAX.
5. UNLESS OTHERWISE SPECIFIED INNER R0.2 MAX
6. DRAFT ANGLE 3°MAX

[TABLE]

1040460417	104046-0417	24.0mm	104046-9004
MATERIAL NO.	CONNECTOR	TAPE WIDTH	EMBOSS TAPE

3	PLASTIC BOBBIN	HI P.S	WHITE
2	COVER TAPE	PET ANTISTATIC	21.3m
1	CARRIER (EMBOSS) TAPE	PET ANTISTATIC	
NO.	DESCRIPTION	MATERIAL	REMARK

NEW RELEASED EC NO: KOR2010-0066 DRAWN: CBCHIN 2009/10/15 CHKD: WYANG 2009/10/20 APPR: YUNSIKKIM 2009/10/21	QUALITY SYMBOLS ▽=0 ▽=0	GENERAL TOLERANCES (UNLESS SPECIFIED)		DIMENSION STYLE MM ONLY		SCALE 4:1	DESIGN UNITS METRIC	THIRD ANGLE PROJECTION		
		4 PLACES ± --- ± ---	3 PLACES ± --- ± ---	2 PLACES ± 0.20 ± ---	1 PLACE ± 0.25 ± ---	DRAWN BY SK.HAN	DATE 2009/03/11	TITLE EMBOSSED PACKAGE 20 W-T-B CONN HEADER ASS'Y-4P		
		ANGULAR ± 3 °				CHECKED BY WY.YANG	DATE 2009/03/11			
		DRAFT WHERE APPLICABLE MUST REMAIN WITHIN DIMENSIONS				SEE TABLE		MOLEX INCORPORATED		
				MATERIAL NO.		DOCUMENT NO.		SHEET NO.		