

8 PIN DIP HIGH SPEED LOW INPUT CURRENT LOGIC GATE PHOTOCOUPLER EL220X SERIES

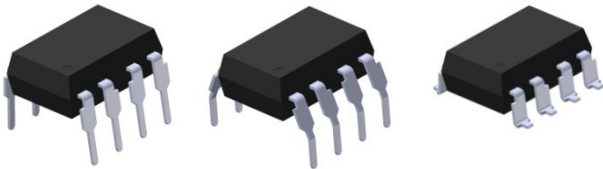

Features

- 1kV/ μ s min. common mode transient immunity
- Guaranteed performance from -40 to 85°C
- Wide V_{CC} range (4.5V to 20V)
- 5Mbd typical signal rate
- Low input current (1.6mA)
- High isolation voltage between input and output (Viso = 5000 V rms)
- Pb free and RoHS compliant.
- UL 1577 approved (No. 214129)
- VDE approved (No. 40028391)
- SEMKO approved
- NEMKO approved
- DEMKO approved
- FIMKO approved

Description

The EL220X are consists of an infrared emitting diode optically coupled to a high speed integrated photo detector logic gate. It is packaged in an 8-pin DIP package and available in SMD options. The detector of EL2200 has a three state output stage and has a detector threshold with hysteresis. The three state output eliminates the need for a pull up resistor and allows for direct drive of data busses. The hysteresis provides differential mode noise immunity and eliminates the potential for output signal chatter.

Applications

- Ground Loop Elimination
- LSTTL to LSTTL or CMOS
- Line Receiver, Data Transmission
- Isolated Buss Driver
- Pulse Transformer Replacement
- Microprocessor System Interface
- Computer Peripheral Interface
- High Speed Logic Ground Isolation

Functional Diagram

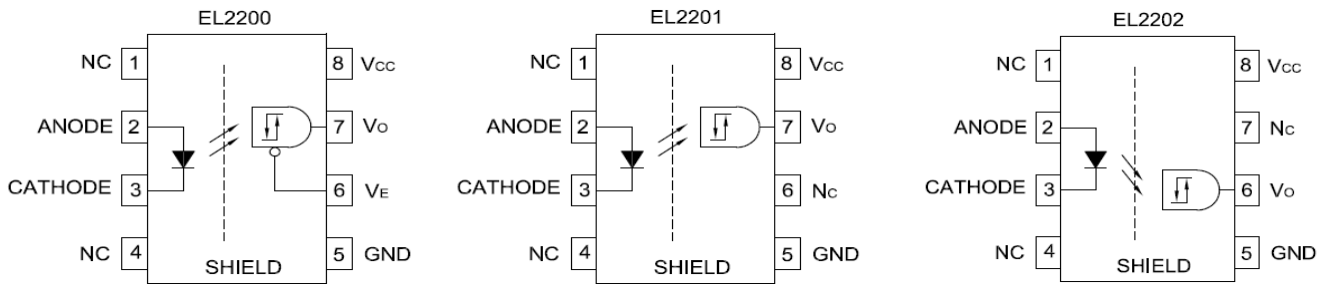

Schematic

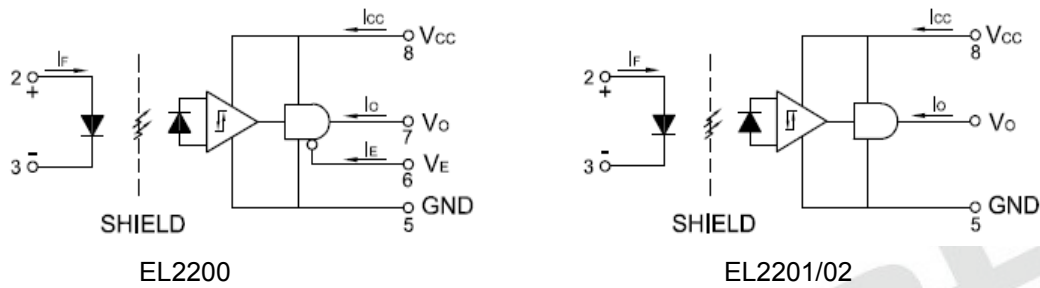

Truth Table

EL2200

Input	Enable	Output
H	H	Z
L	H	Z
H	L	H
L	L	L

EL2201/02

Input	Output
H	H
L	L

Absolute Maximum Ratings (T_A=25°C)

	Parameter	Symbol	Rating	Unit
Input	Forward Current	I _F	50	mA
	Reverse Voltage	V _R	5	V
	Three State Enable Voltage	V _E	20	V
Output	Output Current	I _O	25	mA
	Output Voltage	V _O	20	V
	Supply Voltage	V _{CC}	20	V
Total Package Power dissipation(Note 1)		P _T	210	mW
Isolation Voltage (Note 2)		V _{ISO}	5000	V rms
Operating Temperature		T _{OPR}	-40 ~ +85	°C
Storage Temperature		T _{STG}	-55 ~ +125	°C
Soldering Temperature (Note 3)		T _{SOL}	260	°C

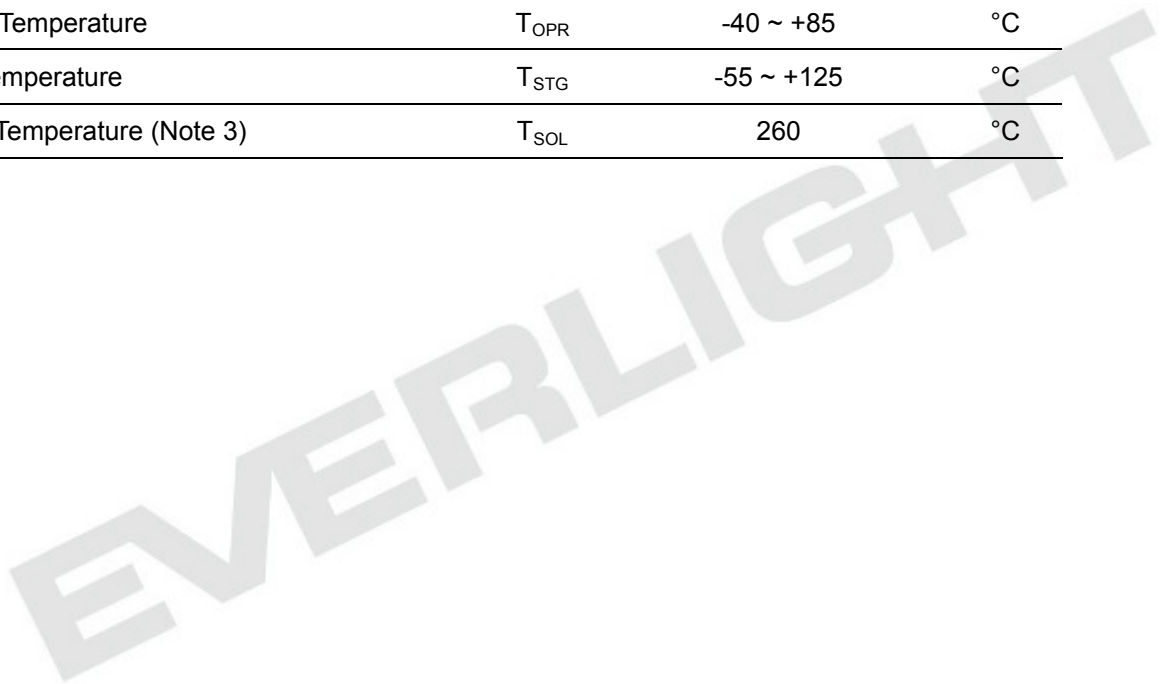

Electrical Characteristics ($T_A = -40$ to 85°C , $V_{CC} = 4.5\text{V}$ to 20V , $I_{F(\text{ON})} = 1.6\text{mA}$ to 5mA ,
 $V_{EH} = 2\text{V}$ to 20V , $V_{EL} = 0\text{V}$ to 0.8V , $I_{F(\text{OFF})} = 0\text{mA}$ unless otherwise specified) (Note 4)

Input

Parameter	Symbol	Min.	Typ.	Max.	Unit	Condition
Forward Voltage	V_F	-	1.4	1.7	V	$I_F = 5\text{mA}$
Reverse Voltage	V_R	5.0	-	-	V	$I_R = 10\mu\text{A}$
Temperature Coefficient of Forward Voltage	$\Delta V_F / \Delta T_A$	-	-1.8	-	mV/ $^\circ\text{C}$	$I_F = 10\text{mA}$
Input Capacitance	C_{IN}	-	60	-	pF	$V_F = 0$, $f = 1\text{MHz}$

Output

Parameter	Symbol	Min.	Typ.	Max.	Unit	Condition
High Level Supply Current	I_{CCH}	-	2.3 3	4.5 6	mA	$V_{CC} = 5.5\text{V}$ $V_{CC} = 20\text{V}$ $I_F = 5\text{mA}$, $I_O = \text{Open}$ $V_E = \text{Don't care}$
Low Level Supply Current	I_{CCL}	-	3.7 4.5	6 7.5	mA	$V_{CC} = 5.5\text{V}$ $V_{CC} = 20\text{V}$ $I_F = 0\text{mA}$, $I_O = \text{Open}$ $V_E = \text{Don't care}$
High Level Enable Current(EL2200 only)	I_{EL}	-	-0.1	-0.32	mA	$V_E = 0.4\text{V}$
Low Level Enable Current(EL2200 only)	I_{EH}	-	-	20	μA	$V_E = 2.7\text{V}$
		-	-	100		$V_E = 5.5\text{V}$
		-	0.005	250		$V_E = 20\text{V}$
High Level Enable Voltage(EL2200 only)	V_{EH}	2.0	-	-	V	
Low Level Enable Voltage(EL2200 only)	V_{EL}	-	-	0.8	V	

Transfer Characteristics ($T_A = -40$ to 85°C , $V_{CC} = 4.5\text{V}$ to 20V , $I_{F(\text{ON})} = 1.6\text{mA}$ to 5mA ,
 $V_{EH} = 2\text{V}$ to 20V , $V_{EL} = 0\text{V}$ to 0.8V , $I_{F(\text{OFF})} = 0\text{mA}$ unless otherwise specified) (Note 4)

Parameter	Symbol	Min.	Typ.	Max.	Unit	Condition
Output Leakage Current	I_{OHH}	-	1.5 2	100 500	μA	$V_{\text{O}}=5.5\text{V}$ $V_{\text{CC}}=4.5\text{V}$ $V_{\text{O}}=20\text{V}$ $I_{\text{F}}=5\text{mA}$
Low Level Output Current	V_{OL}	-	0.33	0.5	V	$V_{\text{CC}} = 4.5\text{V}$, $I_{\text{F}}=0\text{mA}$, $V_{\text{E}}=0.4\text{V}$, $I_{\text{OL}}=6.4\text{mA}$
Input Threshold Current	I_{FT}	-	-	1.6	mA	$V_{\text{CC}} = 4.5\text{V}$, $V_{\text{O}} = 0.5\text{V}$, $V_{\text{E}} = 0.4\text{V}$, $I_{\text{OL}} = 6.4\text{mA}$
Logic High Output Voltage	V_{OH}	2.4	$V_{\text{CC}} - 1.8$	-	V	$I_{\text{OH}} = -2.6\text{mA}$
High Impedance State Output Current (EL2200 only)	I_{OZL}	-	-	-20	μA	$V_{\text{O}} = 0.4\text{V}$, $I_{\text{F}} = 5\text{mA}$, $V_{\text{EN}} = 2\text{V}$
	I_{OZH}	-	-	20	μA	$V_{\text{O}} = 2.4\text{V}$
		-	-	100		$V_{\text{O}} = 5.5\text{V}$ $I_{\text{F}} = 5\text{mA}$, $V_{\text{EN}} = 2\text{V}$
Logic Low Short Circuit Output Current	I_{OSL}	25 40	-	-	mA	$V_{\text{O}} = V_{\text{CC}} = 5.5\text{V}$ $I_{\text{F}} = 0\text{mA}$ $V_{\text{O}} = V_{\text{CC}} = 20\text{V}$ (Note 5)
Logic High Short Circuit Output Current	I_{OSH}	-10 -25	-	-	mA	$V_{\text{CC}} = 5.5\text{V}$ $I_{\text{F}} = 5\text{mA}$, $V_{\text{CC}} = 20\text{V}$ $V_{\text{O}} = \text{GND}$ (Note 5)
Input Current Hysteresis	I_{HYS}	-	0.03	-	mA	$V_{\text{CC}} = 4.5\text{V}$

Switching Characteristics ($T_A = -40$ to 85°C , $V_{CC} = 4.5\text{V}$ to 20V , $I_{F(\text{ON})} = 1.6\text{mA}$ to 5mA , $I_{F(\text{OFF})} = 0\text{mA}$ unless otherwise specified) (Note 4)

Parameter	Symbol	Min.	Typ.	Max.	Unit	Condition
Propagation Delay Time to Output High Level	T_{PLH}	-	100	300	ns	(Note 6&8) , Fig. 11
Propagation Delay Time to Output Low Level	T_{PHL}	-	105	300	ns	(Note 7&8), Fig. 11
Output Rise Time	t_r	-	45	-	ns	(Note 9) , Fig. 11
Output Fall Time	t_f	-	10	-	ns	(Note 10) , Fig. 11
Enable Propagation Delay Time to Output High Level (EL2200 only)	t_{PZH}	-	20	-	ns	Fig. 12
Enable Propagation Delay Time to Output Low Level (EL2200 only)	t_{PZL}	-	25	-	ns	Fig. 12
Disable Propagation Delay Time to Output High Level (EL2200 only)	t_{PHZ}	-	130	-	ns	Fig. 12
Disable Propagation Delay Time to Output Low Level (EL2200 only)	t_{PLZ}	-	35	-	ns	Fig. 12
Common Mode Transient Immunity at Output High	CM_H	1000	-	-	V/ μS	$I_F=5\text{mA}$ $V_{OH(\text{Min.})}=2\text{V}$ (Note 11)
Common Mode Transient Immunity at Output Low	CM_L	1000	-	-	V/ μS	$I_F=0\text{mA}$ $V_{OL(\text{Max.})}=2\text{V}$ (Note 12)

$|V_{CM}|=50\text{V}$
 $V_{CC}=5\text{V}$
 $T_A = 25^\circ\text{C}$
 (Fig. 13)

Typical Electro-Optical Characteristics Curves

Figure 1. Input Forward Current vs. Forward Voltage

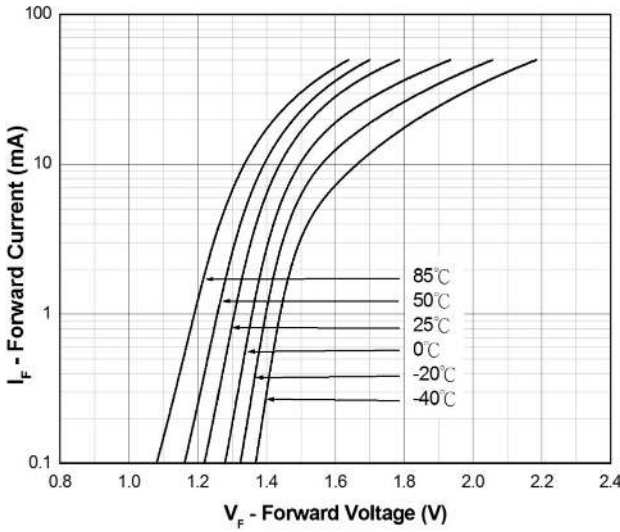

Figure 2. Output Voltage vs. Input Forward Current

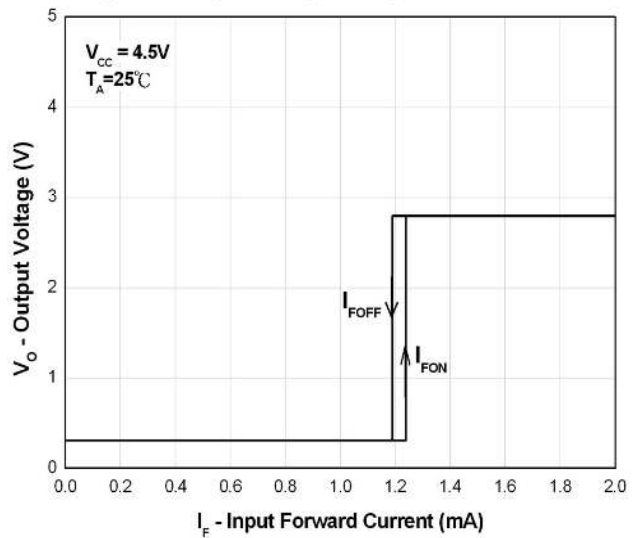

Figure 3. Input Threshold Current vs. Ambient Temperature

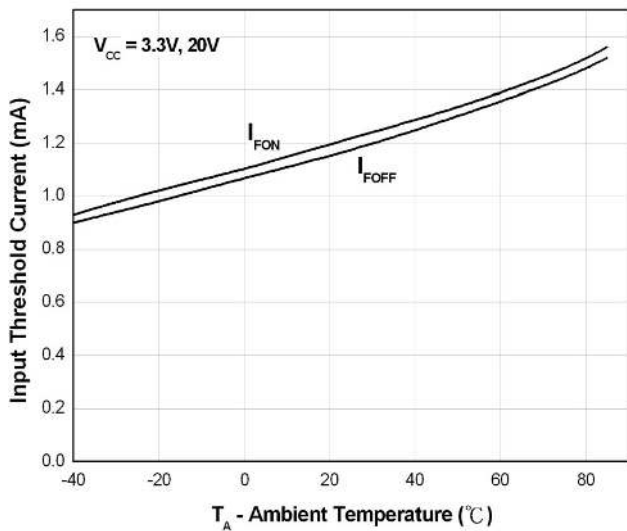

Figure 4. Logic Low Output Voltage vs. Ambient Temperature

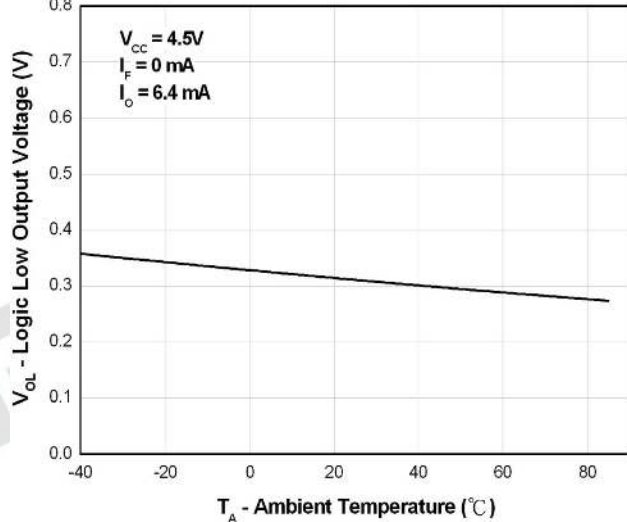

Figure 5. Logic High Output Voltage vs. Supply Voltage

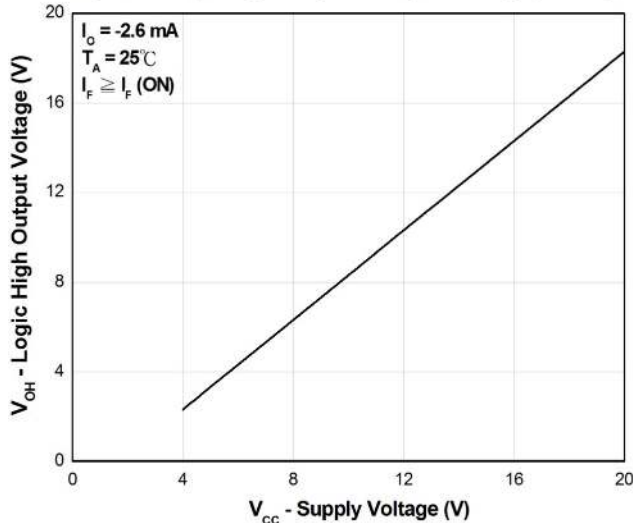

Figure 6. Logic High Output Current vs. Ambient Temperature

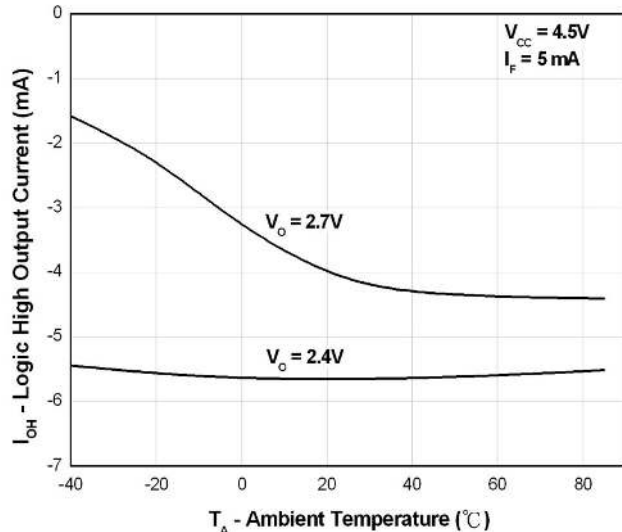

Figure 7. Propagation Delay vs. Ambient Temperature

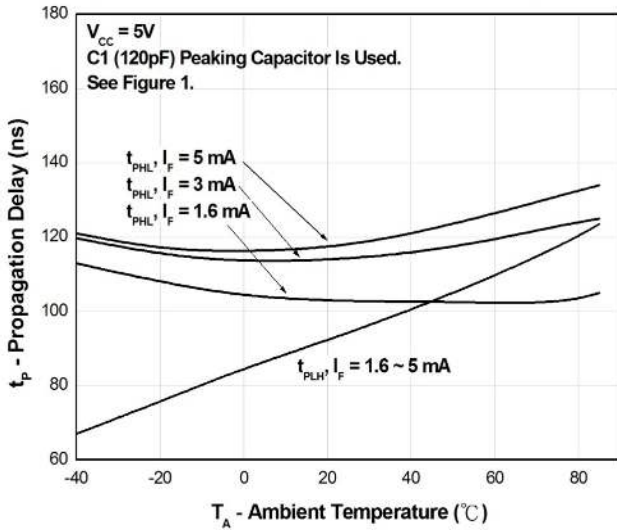

Figure 8. Typical Logic Low Enable Propagation Delay vs. Temperature.

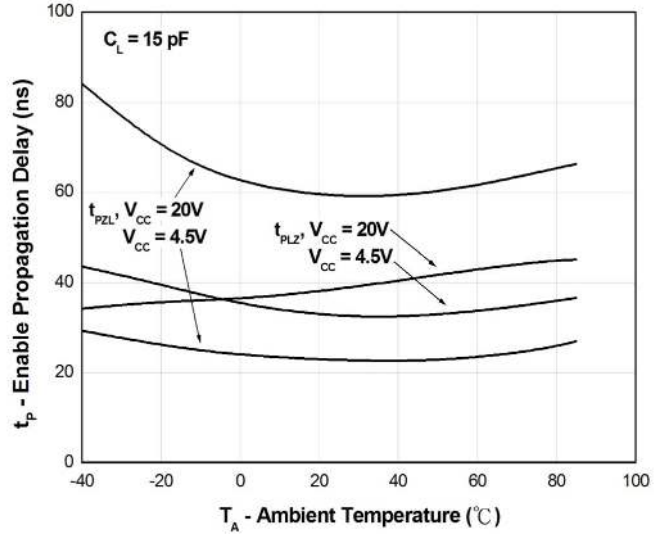

Figure 9. Typical Logic Low Enable Propagation Delay vs. Temperature.

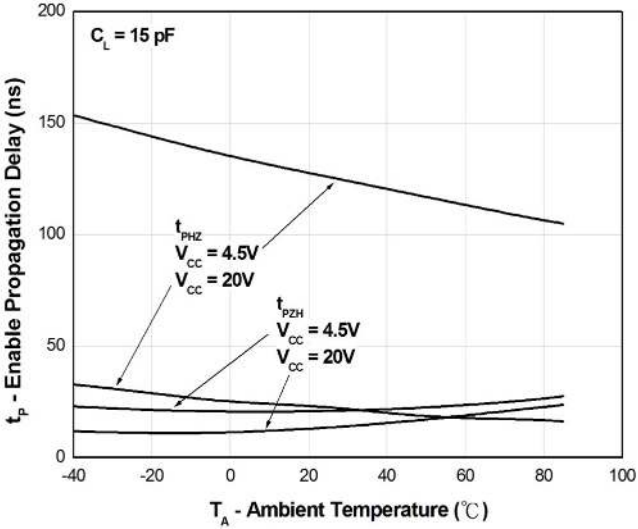
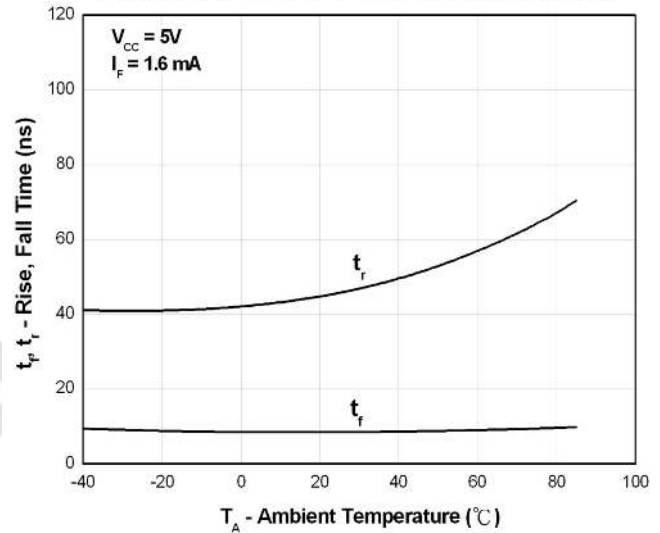
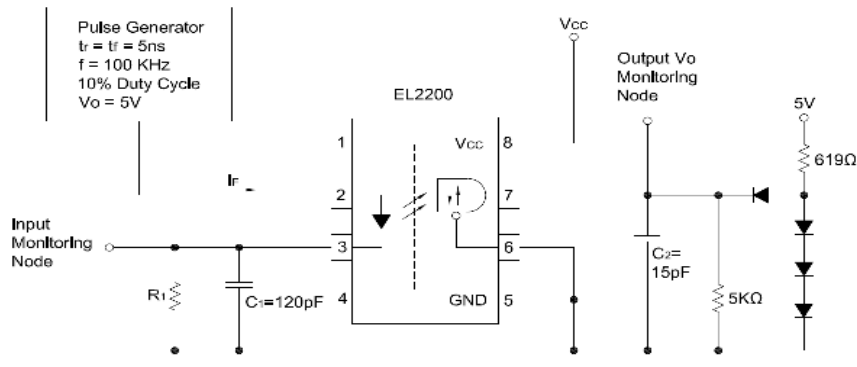

Figure 10. Rise, Fall Time vs Ambient Temperature





The Probe and Jig Capacitances are Included in C_1 and C_2
 All Diodes are 1N916 and 1N3064.

R_1	2.25K Ω	1.2K Ω	720 Ω
$I_{F(ON)}$	1mA	3mA	5mA

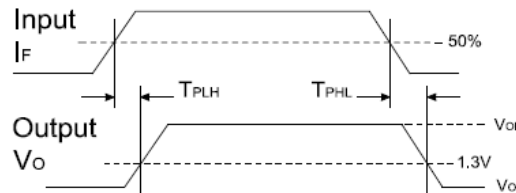

Fig. 11 Test Circuit and Waveforms for t_{PLH} , t_{PHL} , t_r , and t_f (Note 13)

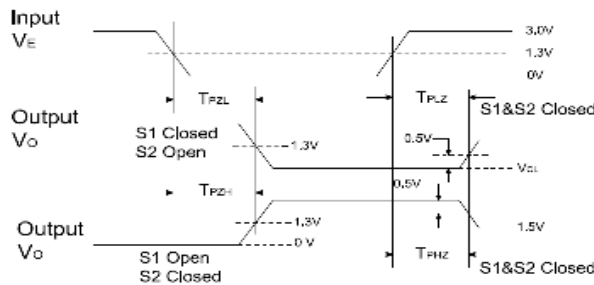
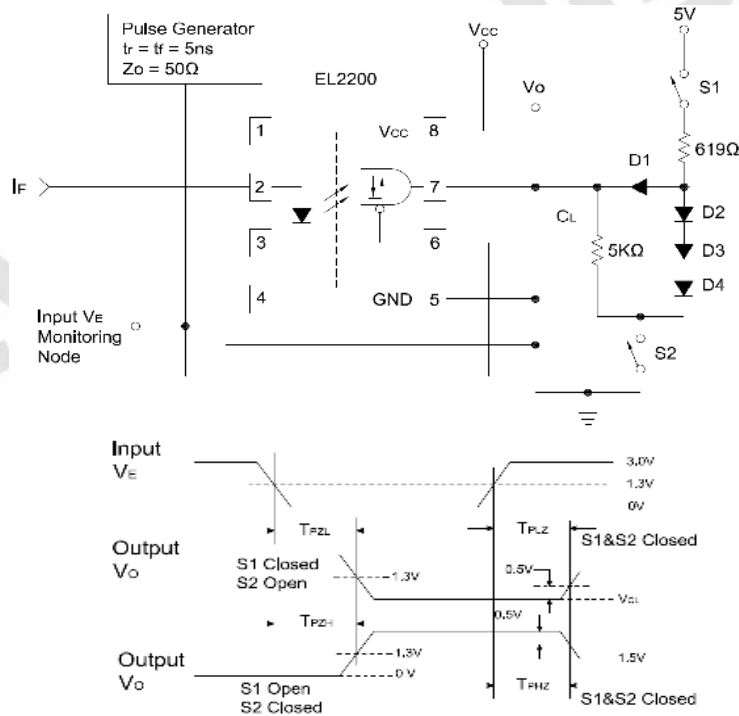

Fig. 12 Test Circuit and Waveform for t_{PHZ} and t_{PLZ} , t_{PLZ} and t_{PZL}

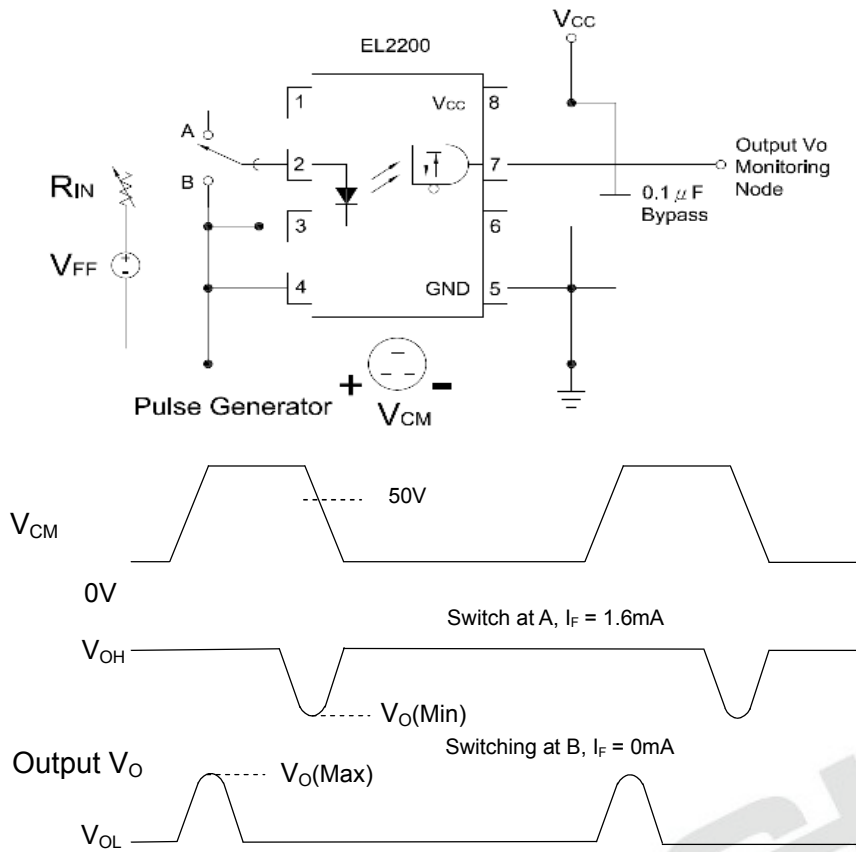

Fig. 13 Test Circuit Common Mode Transient Immunity (Note 13)

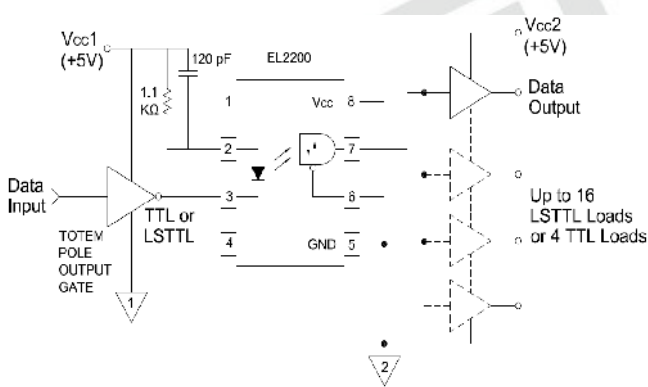

Fig. 14 Recommended LSTTL to LSTTL Circuit.
 (Note 13)

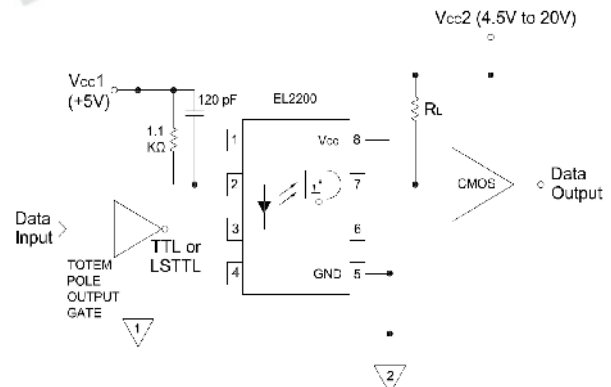

Fig. 15 LSTTL to CMOS Interface Circuit.
 (Note 13)

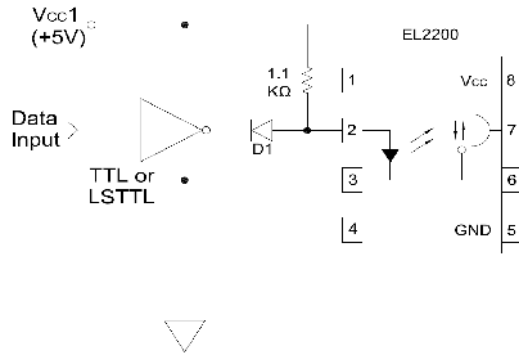

Fig. 16 Recommended LED Drive Circuit.

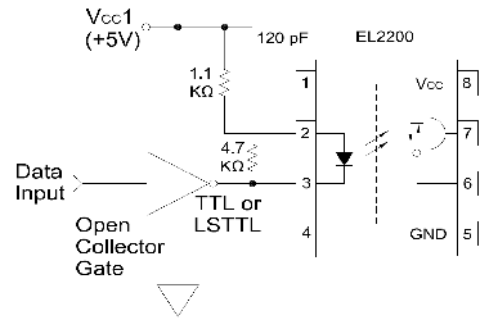

Fig. 17 Series LED Drive With Open Collector Gate.
 (4.7KΩ Resistor Shunts I_{OH} from the LED)

Note

1. Derate total package power dissipation, P_T , linearly above 70°C free air temperature at a rate of 4.5 mW/°C.
2. AC for 1 minute, R.H.= 40 ~ 60% R.H. In this test, pins 1, 2, 3 & 4 are shorted together, and pins 5, 6, 7 & 8 are shorted together.
3. For 10 seconds.
4. The VCC supply must be bypassed by a 0.1μF capacitor or larger. This can be either a ceramic or solid tantalum capacitor with good high frequency characteristic and should be connected as close as possible to the package V_{CC} and GND pins.
5. Duration of output short circuit time should not exceed 10 ms.
6. t_{PLH} Propagation delay is measured from the 50% level on the LOW to HIGH transition of the input current pulse to the 1.3 V level on the LOW to HIGH transition of the output voltage pulse.
7. t_{PHL} Propagation delay is measured from the 50% level on the HIGH to LOW transition of the input current pulse to the 1.3 V level on the HIGH to LOW transition of the output voltage pulse.
8. When the peaking capacitor is omitted, propagation delay times may increase by 100 ns.
9. t_r Rise time is measured from the 10% to the 90% levels on the LOW to HIGH transition of the output pulse.
10. t_f Fall time is measured from the 90% to the 10% levels on the HIGH to LOW transition of the output pulse.
11. CM_H – The maximum tolerable rate of rise of the common mode voltage to ensure the output will remain in the HIGH state (i.e., $V_{OUT} > 2.0V$).
12. CM_L – The maximum tolerable rate of rise of the common mode voltage to ensure the output will remain in the LOW output state (i.e., $V_{OUT} < 0.8V$).
13. For testing EL2201/02 the enable pin must be floating.

Order Information

Part Number

EL2200Y(Z)-V

EL2201Y(Z)-V

EL2202Y(Z)-V

Note

- Y = Lead form option (S, S1, M or none)
- Z = Tape and reel option (TA, TB or none).
- V = VDE (optional)

Option	Description	Packing quantity
None	Standard DIP-8	45 units per tube
M	Wide lead bend (0.4 inch spacing)	45 units per tube
S (TA)	Surface mount lead form + TA tape & reel option	1000 units per reel
S (TB)	Surface mount lead form + TB tape & reel option	1000 units per reel
S1 (TA)	Surface mount lead form (low profile) + TA tape & reel option	1000 units per reel
S1 (TB)	Surface mount lead form (low profile) + TB tape & reel option	1000 units per reel

Package Dimension
(Dimensions in mm)

Standard DIP Type

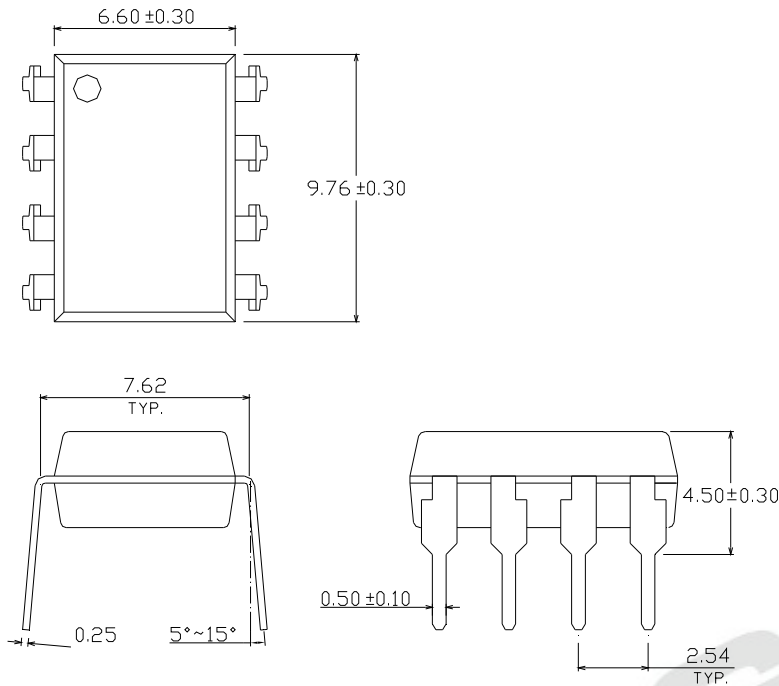

Option M Type

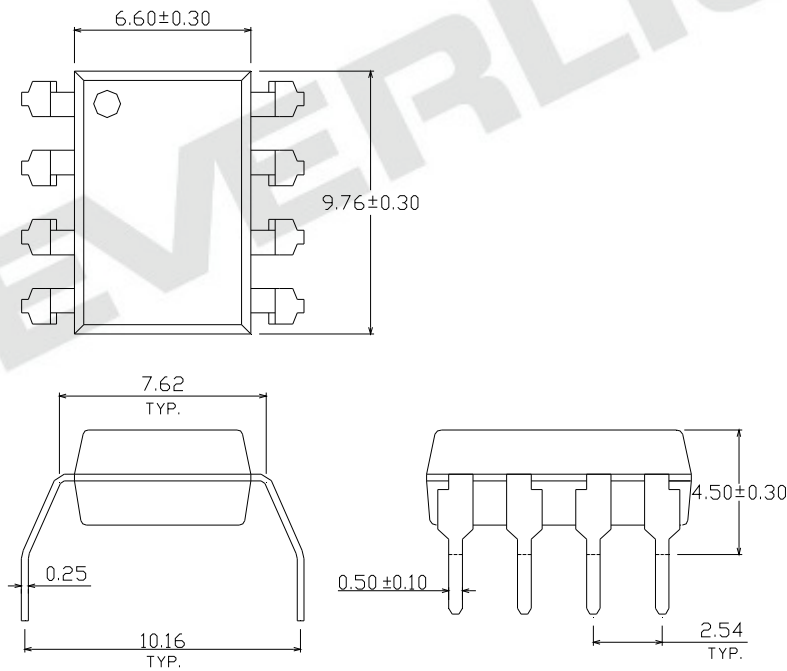

Option S Type

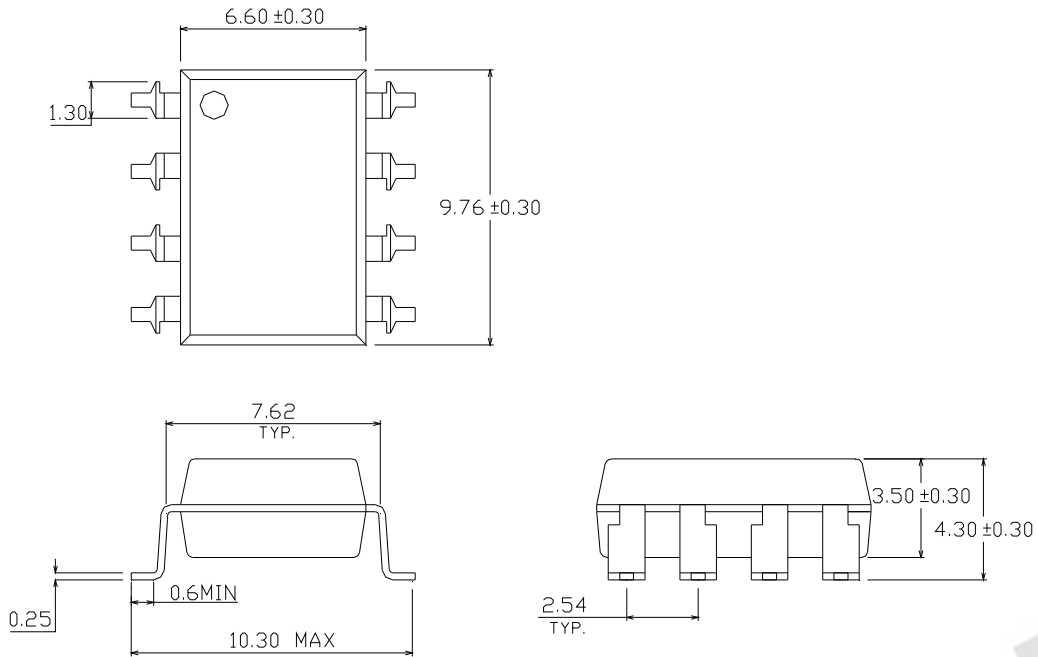

Option S1 Type

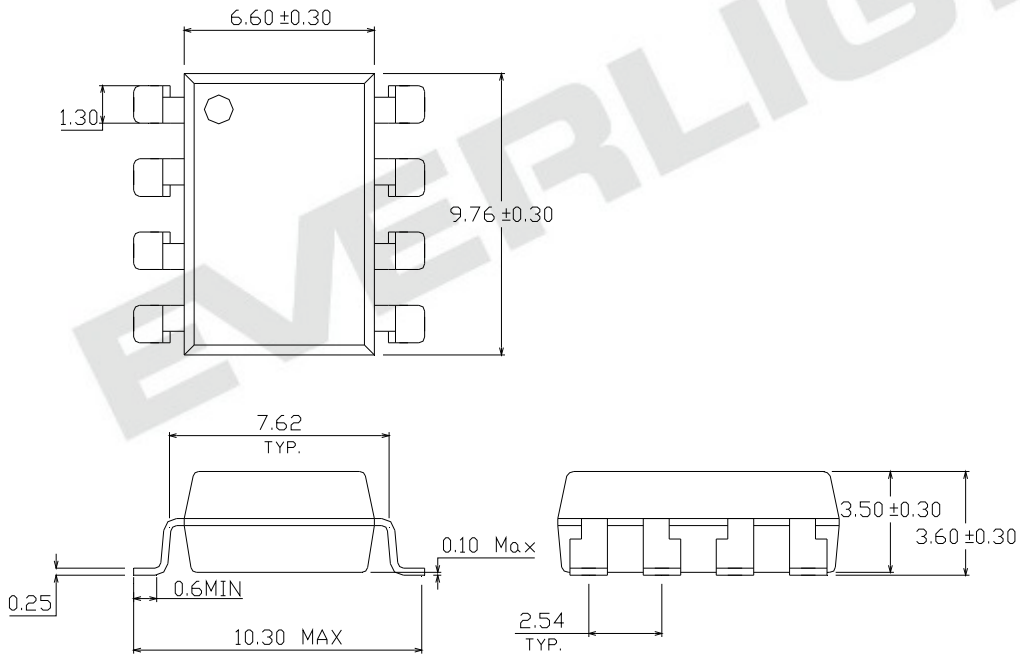

Recommended Pad Layout for Surface Mount Leadform

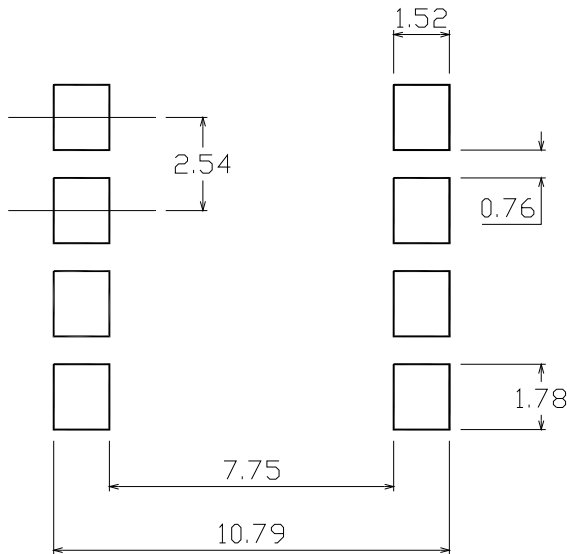

Device Marking

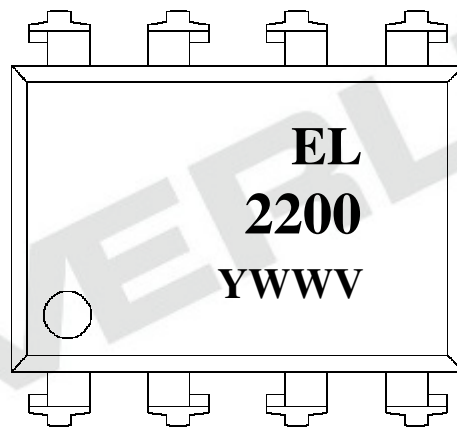

Notes

- EL denotes EVERLIGHT
- 2200 denotes Device Number
- Y denotes 1 digit Year code
- WW denotes 2 digit Week code
- V denotes VDE (optional)

Tape & Reel Packing Specifications

Option TA

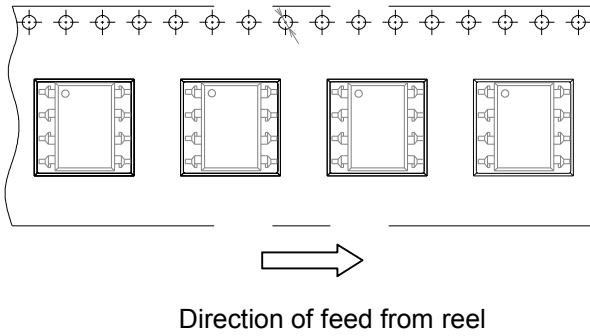

Option TB

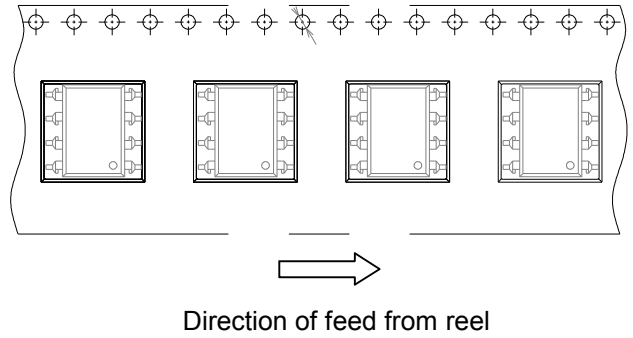

Tape Dimension

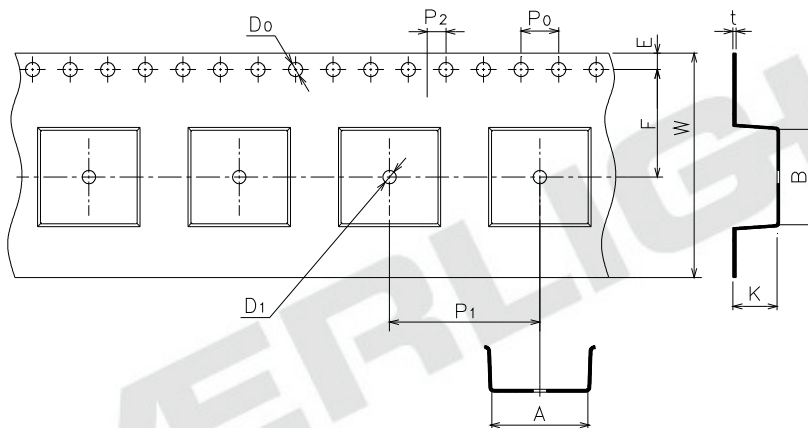

Dimension No.	A	B	D₀	D₁	E	F
Dimension(mm)	10.4±0.1	10.0±0.1	1.5+0.1/-0	1.5±0.25/-0	1.75±0.1	7.5±0.1
Dimension No.	P₀	P₁	P₂	t	W	K
Dimension(mm)	4.0±0.1	12.0±0.1	2.0±0.05	0.4±0.05	16.0±0.3/	4.5±0.1

Precautions for Use

1. Soldering Condition

1.1 (A) Maximum Body Case Temperature Profile for evaluation of Reflow Profile

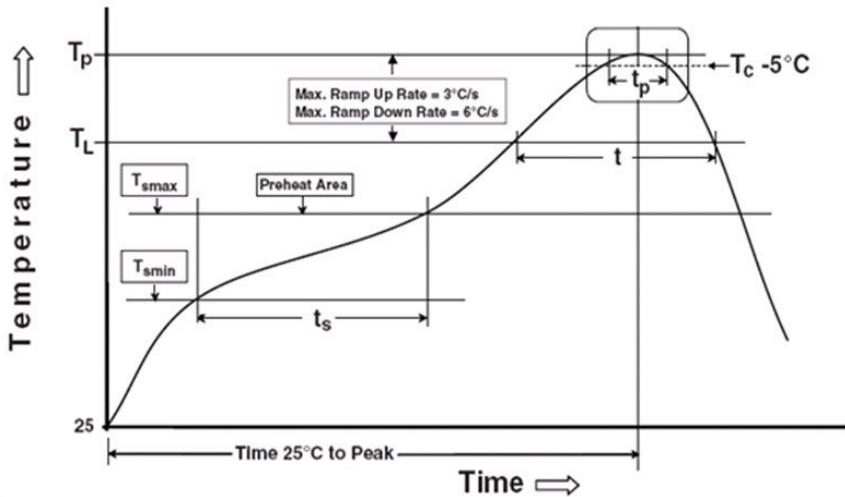

Note:

Reference: IPC/JEDEC J-STD-020D

Preheat

Temperature min (T_{smin})	150 °C
Temperature max (T_{smax})	200°C
Time (T_{smin} to T_{smax}) (t_s)	60-120 seconds
Average ramp-up rate (T_{smax} to T_p)	3 °C/second max

Other

Liquidus Temperature (T_L)	217 °C
Time above Liquidus Temperature (t_L)	60-100 sec
Peak Temperature (T_p)	260°C
Time within 5 °C of Actual Peak Temperature: $T_p - 5^\circ\text{C}$	30 s
Ramp- Down Rate from Peak Temperature	6°C /second max.
Time 25°C to peak temperature	8 minutes max.
Reflow times	3 times

DISCLAIMER

1. Above specification may be changed without notice. EVERLIGHT will reserve authority on material change for above specification.
2. When using this product, please observe the absolute maximum ratings and the instructions for using outlined in these specification sheets. EVERLIGHT assumes no responsibility for any damage resulting from use of the product which does not comply with the absolute maximum ratings and the instructions included in these specification sheets.
3. These specification sheets include materials protected under copyright of EVERLIGHT corporation. Please don't reproduce or cause anyone to reproduce them without EVERLIGHT's consent.

EVERLIGHT