

4

3

2

1

REVISIONS			
REV.	DESCRIPTION	DATE	DWN
-	INITIAL RELEASE	8/31/2020	FY

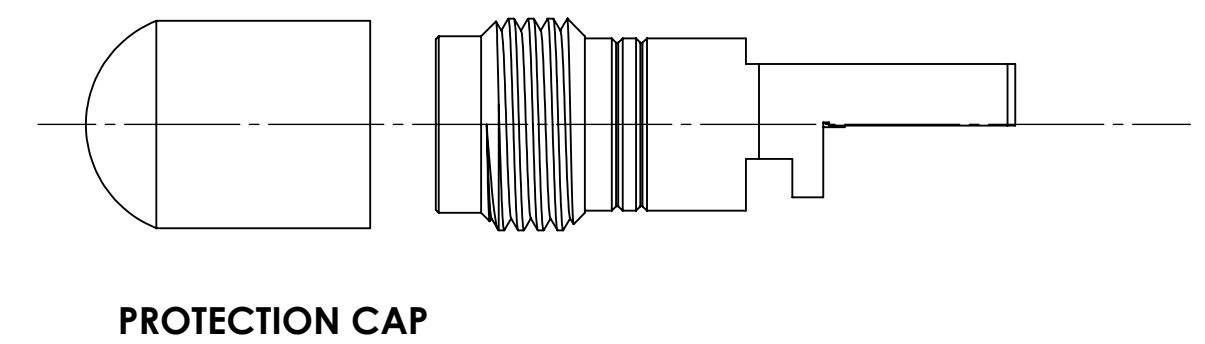
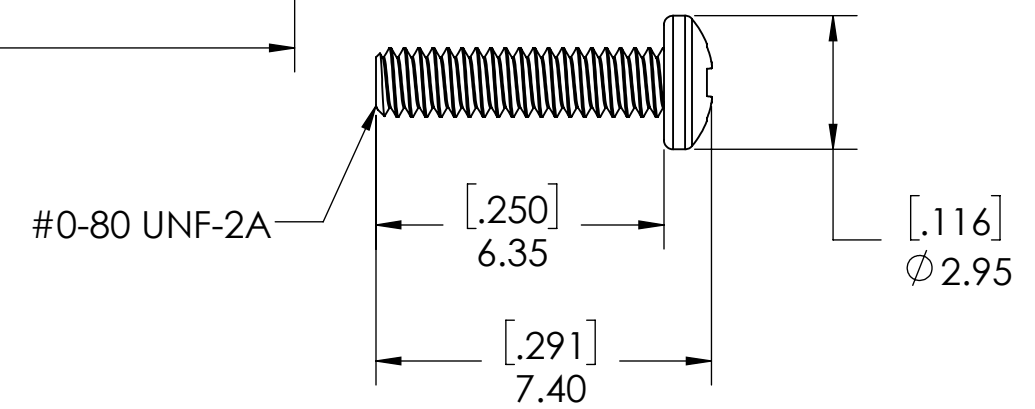
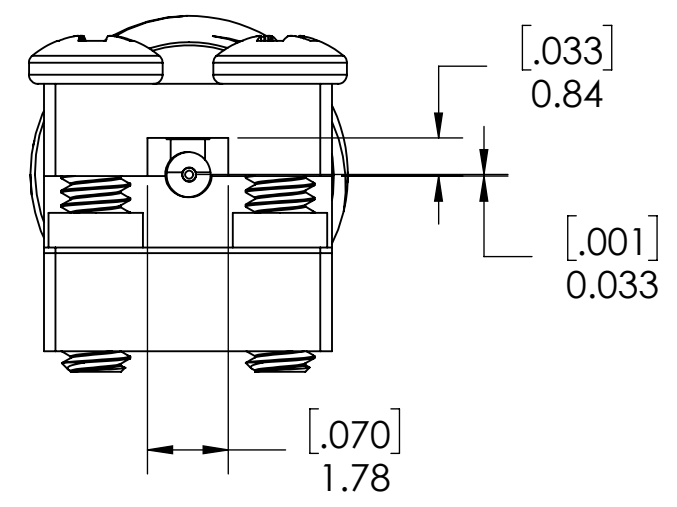
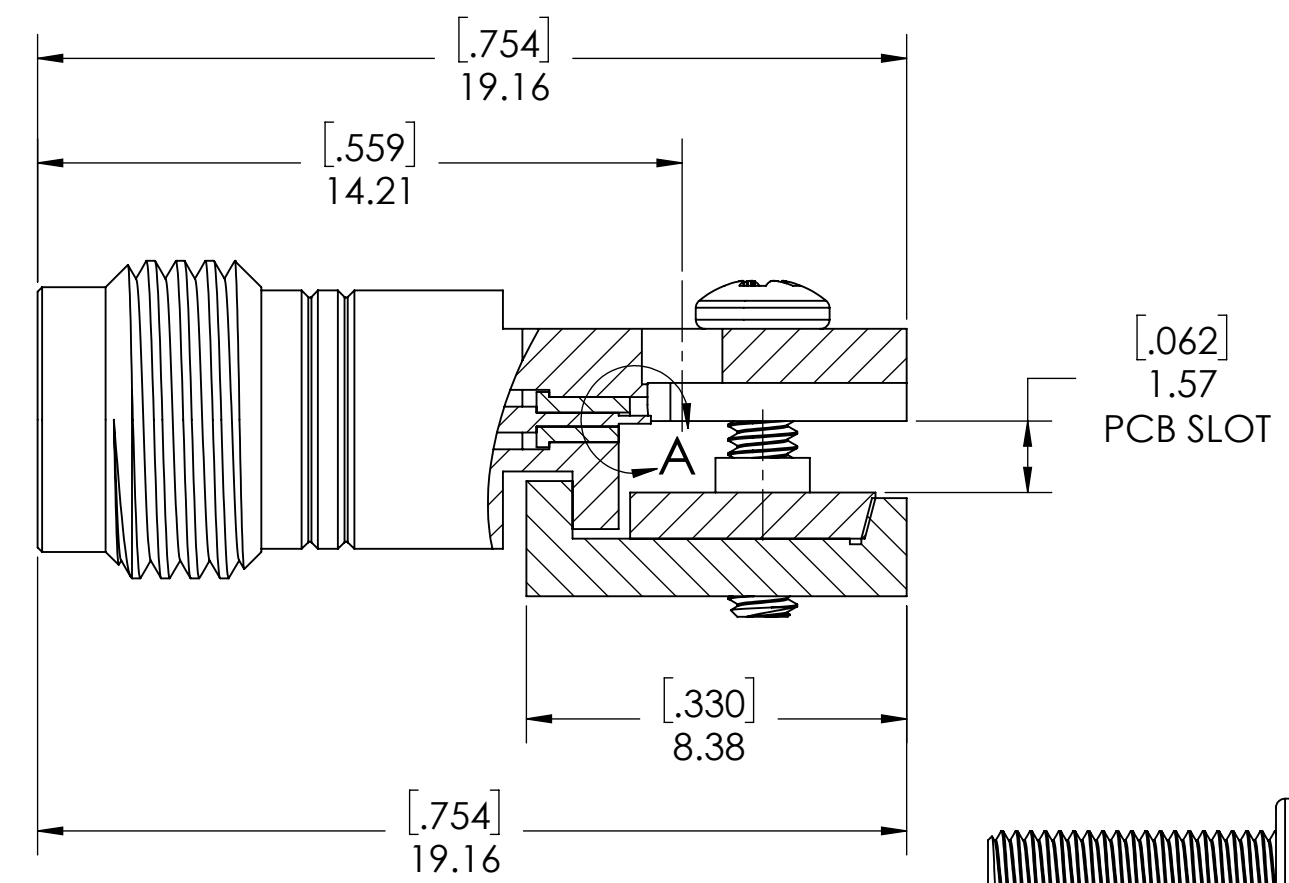
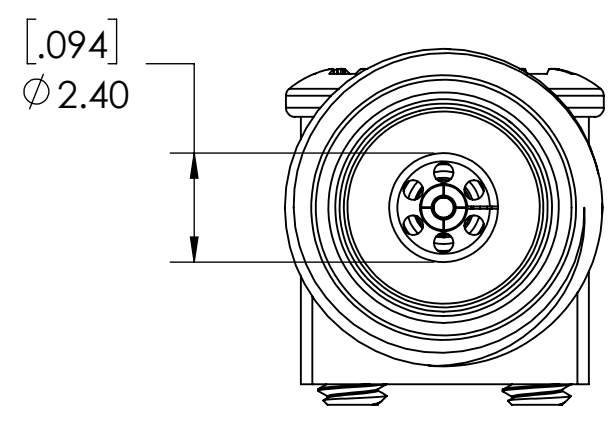
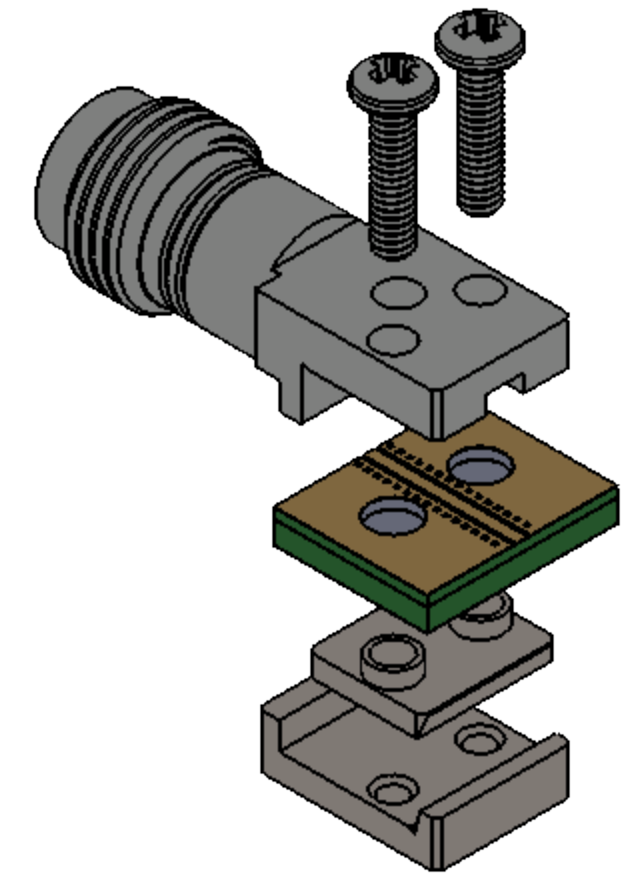
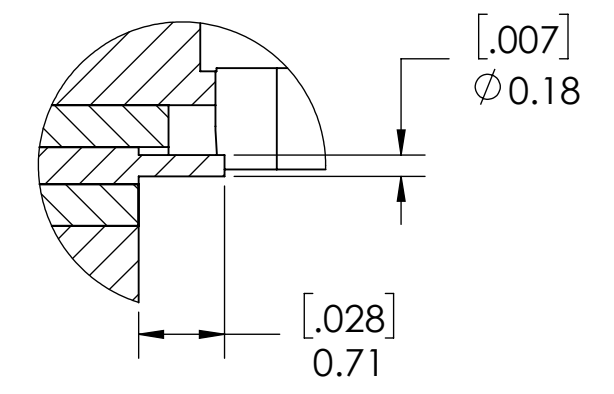
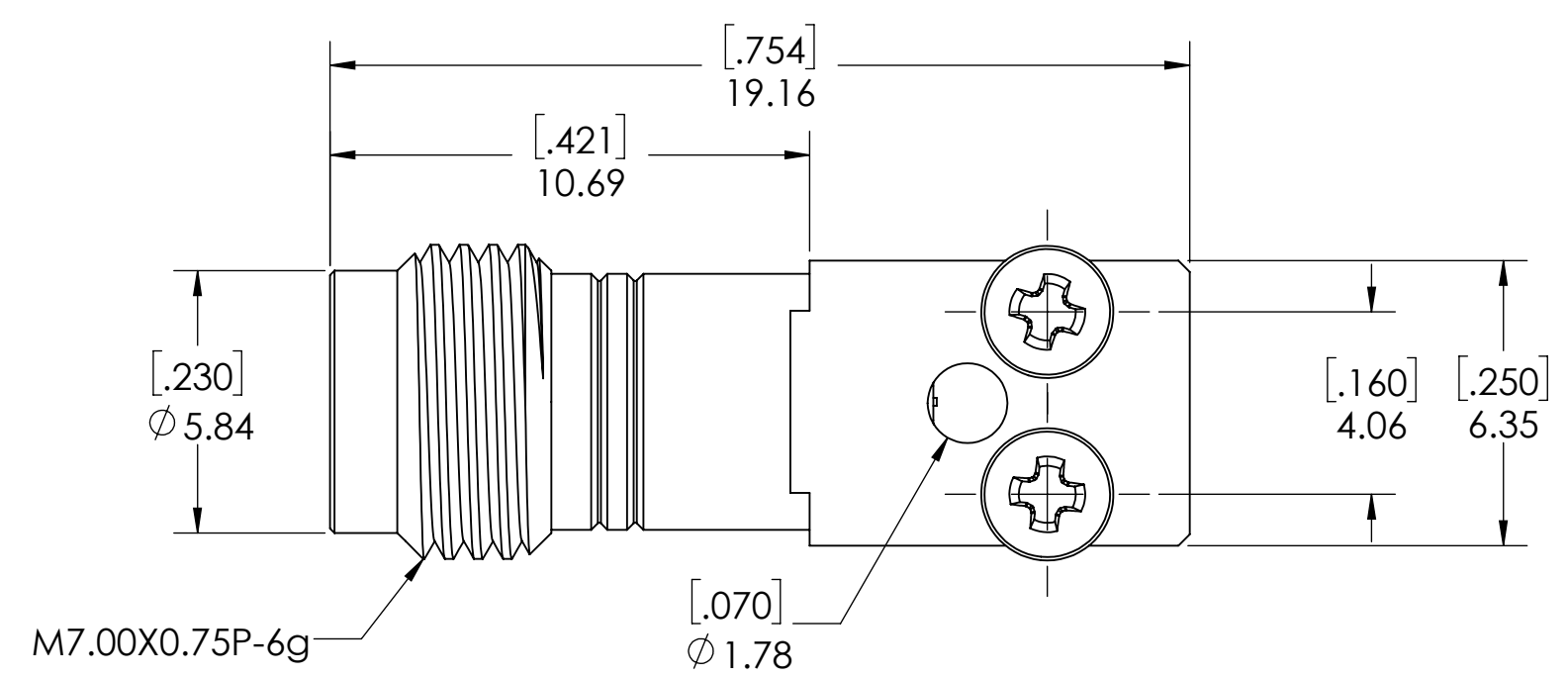

NOTE(S):  
 1. These characteristics are typical and for reference.  
 2. DYH: 60-20028-44070A  
 3. See sheet 2 for standard PCB interface definition.  
 4. See sheet 3 for non-standard PCB interface definition.

MATERIAL(S):	ELECTRICAL(S):	MECHANICAL(S):	ENVIRONMENTAL(S):
Body/Screws: Stainless Steel Locking Block: Brass Center Conductor: Beryllium Copper Insulator: PCTFE, white RoHS Compliant Protective Cap: Soft PVC Color: Blue	Impedence: 50 Ohms Nominal Frequency Range: DC to 50 GHz VSWR: 1.30 max at 50 GHz Working Voltage: 500 V RMS max @ Sea Level Dielectric Withstand Voltage: 500 V RMS max. Insulation Resistance: 5000 megaohms min. Contact Resistance: Initial: Center Contact: 1.5 Milliohms max Outer Contact: 0.8 Milliohms max	Mating Characteristics: Interface per MIL-STD-348 Force to Engage & Disengage: Torque: 2 inch-pounds max Longitudinal Force: NA Connector Durability: 500 Cycles min. Permeability: Less than 2.0 mu. Center Contact Retention: Axial Force: 6 pounds min. Radial Force: NA	Temperature Range: -55 °C to +85 °C Moisture Resistance: MIL-STD-202, Method 103, Test Condition B Corrosion: MIL-STD-202, Method 101, Test Condition B Vibration: MIL-STD-202, Method 204, Test Condition A Shock: MIL-STD-202, Method 213, Test Condition 1

FINISH(ES):
Body/Screw: Passivated Locking Block: Nickel plating Center Conductor: Becu ,Gold Plating

APPLICABLE CARLISLE IT DOCUMENTS		
WORK STANDARD	PROD INSTRUC	ASSY INSTRUC
NA	NA	NA
-		

**NOTICE**  
 THIS DRAWING EMBODIES A CONFIDENTIAL PROPRIETARY DESIGN ORIGINATED BY CARLISLE INTERCONNECT TECHNOLOGIES & ALL DESIGN, MANUFACTURING, REPRODUCTION, USE & SALE RIGHTS REGARDING THE SAME ARE EXPRESSLY RESERVED. IT IS SUBMITTED UNDER A CONFIDENTIAL RELATIONSHIP FOR A SPECIFIED PURPOSE & THE RECIPIENT AGREES BY ACCEPTING THIS DRAWING NOT SUPPLY OR DISCLOSE ANY INFORMATION REGARDING IT TO ANY UNAUTHORIZED PERSON TO INCORPORATE IN OTHER PROJECTS ANY SPECIAL FEATURES PECULIAR TO THIS DESIGN. ALL PATENT RIGHTS HERETO ARE EXPRESSLY RESERVED BY CARLISLE INTERCONNECT TECHNOLOGIES, CERRITOS, CALIFORNIA 90703.

TOLERANCES AND NOTES	APPROVAL	INITIALS	DATE
EXCEPT AS NOTED	DRAWN BY	FY	8/31/2020
THIRD ANGLE PROJECTION	CHECKED BY		
SCALE 8:1	DESIGN ENG	PV	9/26/2019
DIMENSIONS ARE IN [INCHES] ANGLES ±2° MM	APPR BY		
.XX DECIMALS ±.063 .XXX DECIMALS ±.01			

Dongguan City, Guangdong P.R. China 523533

TITLE: Edge Launch, Narrow Body, Solderless, 2.4mm, Connector

SCALE: 8:1  
SUB-DIRECTORY/ \_OUTLINE/

SHEET 1 OF 3  
DRAWING NO. TMB-E4F2-1L1-01

4

3

2

1

D

C

B

A

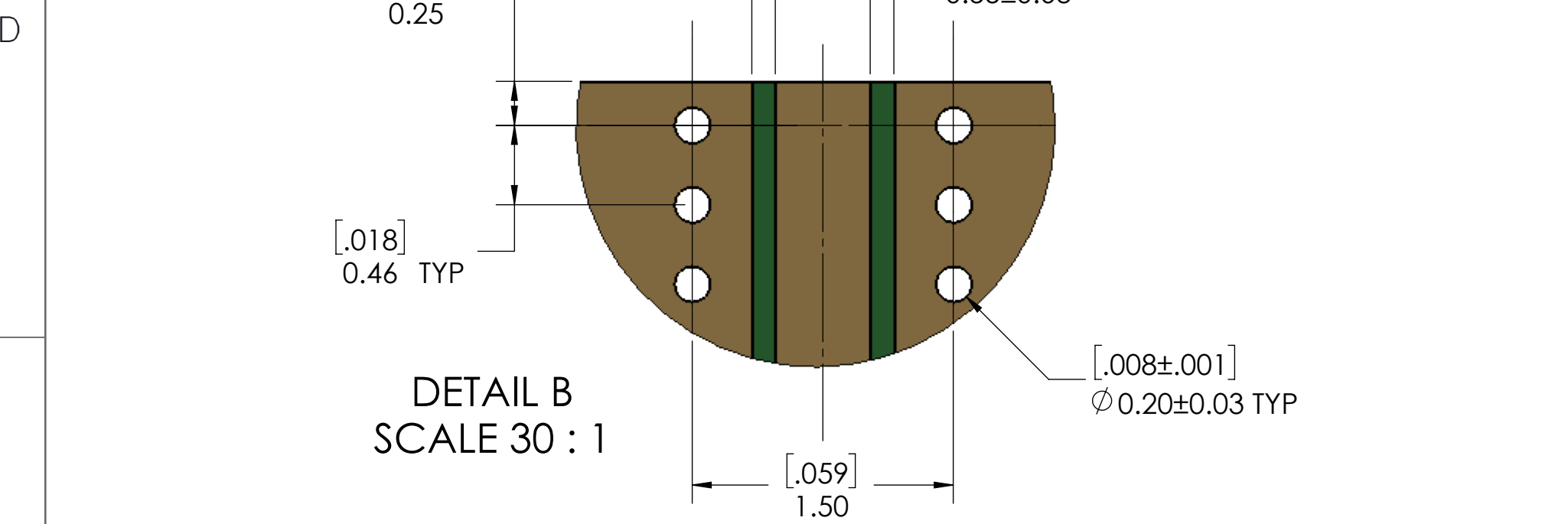

DETAIL B  
SCALE 30 : 1

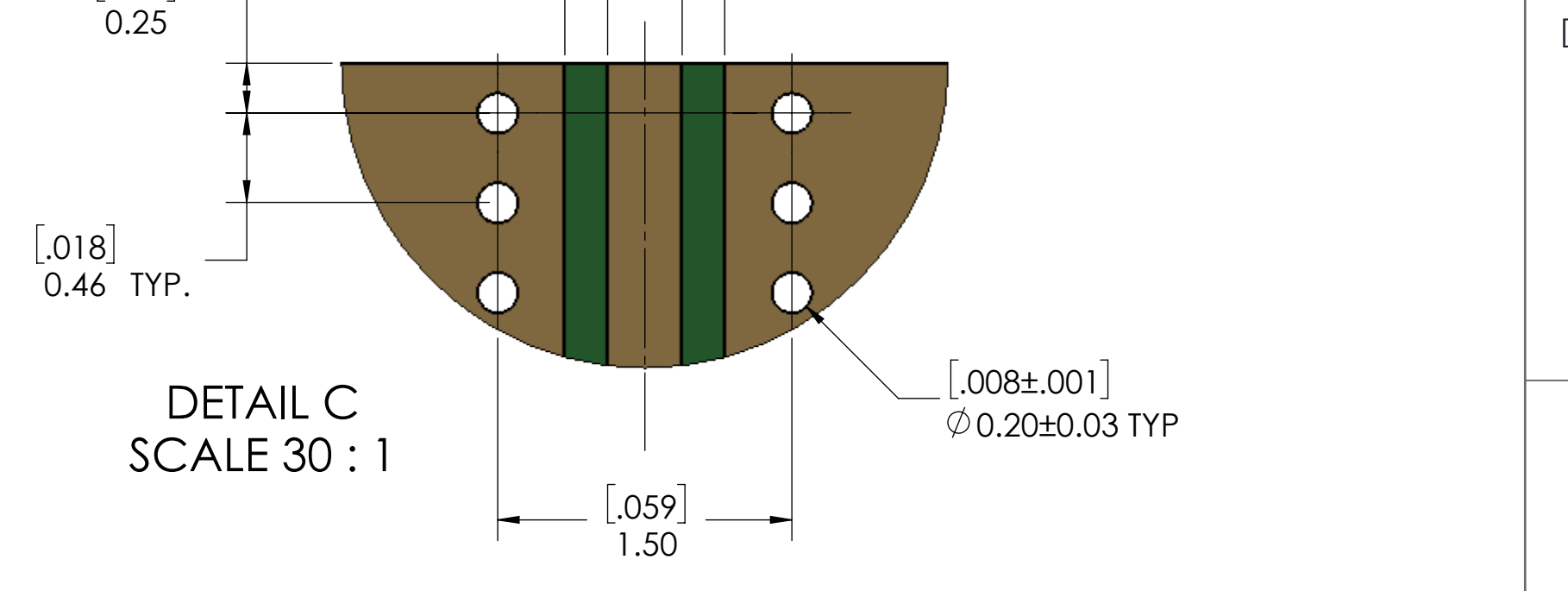

DETAIL C  
SCALE 30 : 1

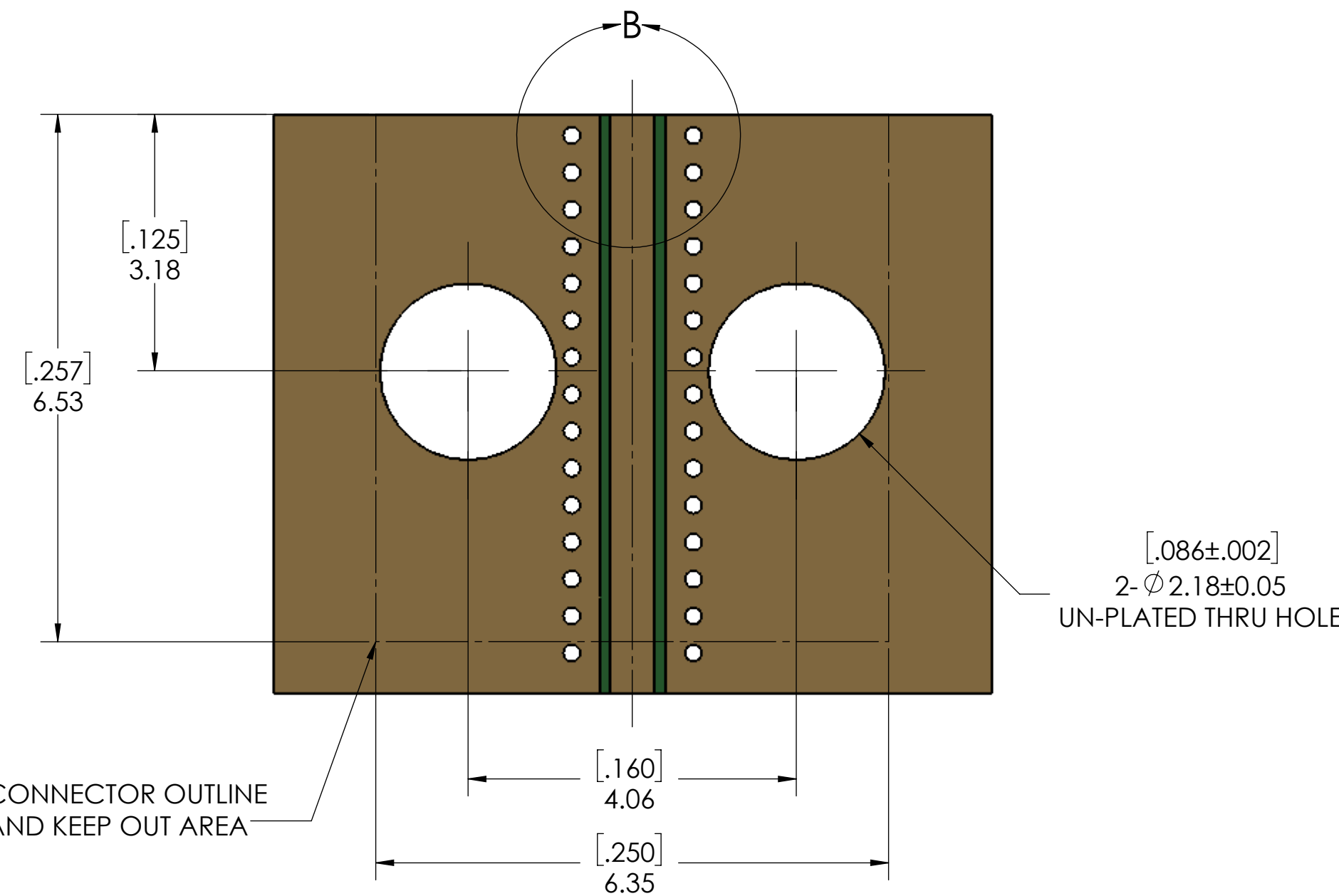

[0.086±.002]  
2- Ø2.18±0.05  
UN-PLATED THRU HOLE

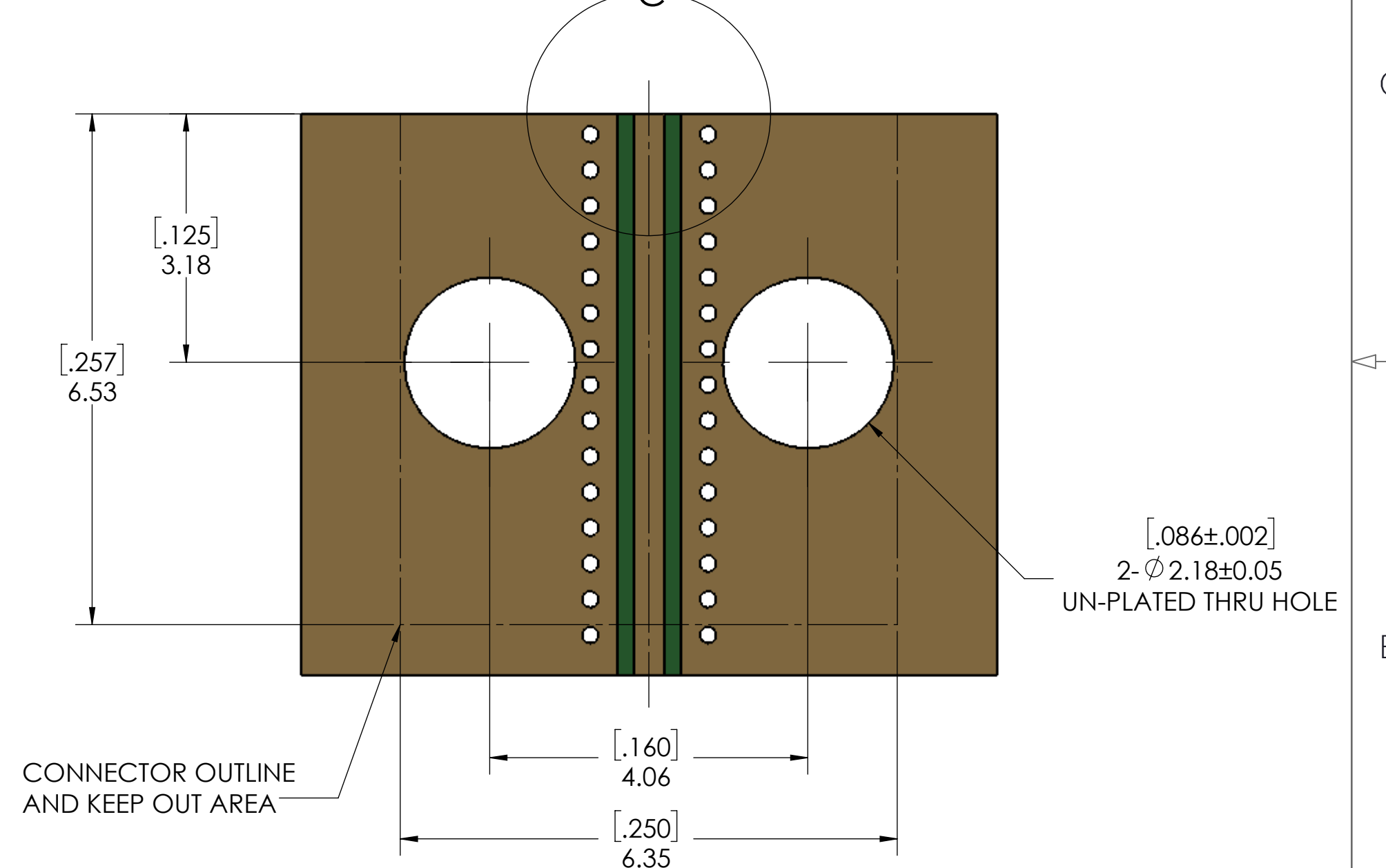

[0.086±.002]  
2- Ø2.18±0.05  
UN-PLATED THRU HOLE

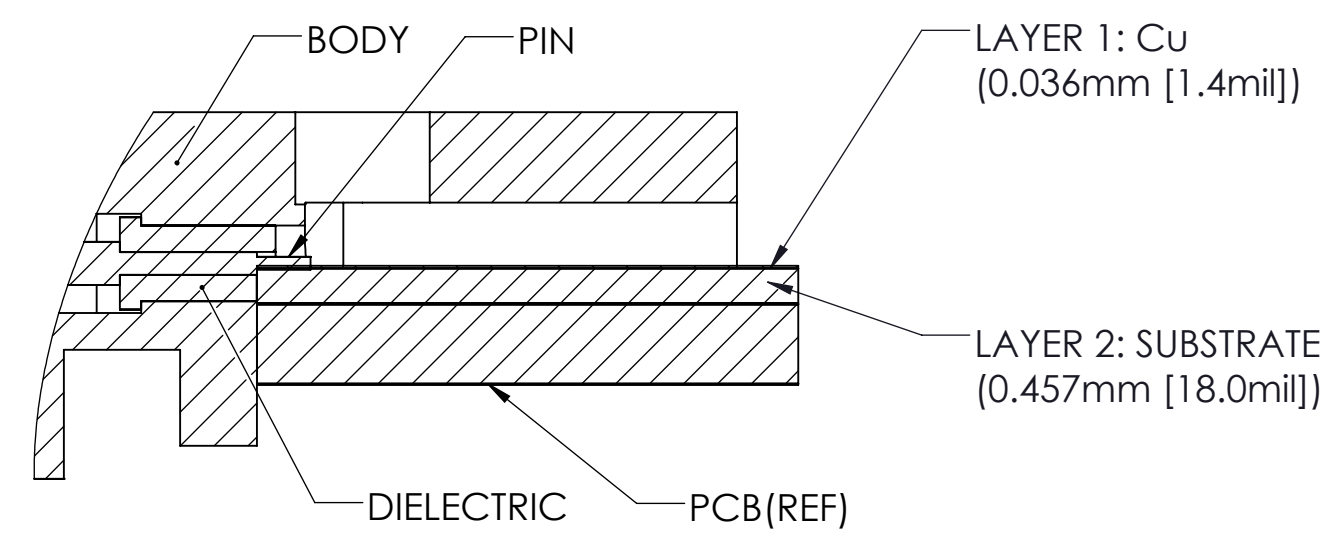

OPTION 1 : 0.457mm [18.0mil] THICK SUBSTRATE (LAYER 2)

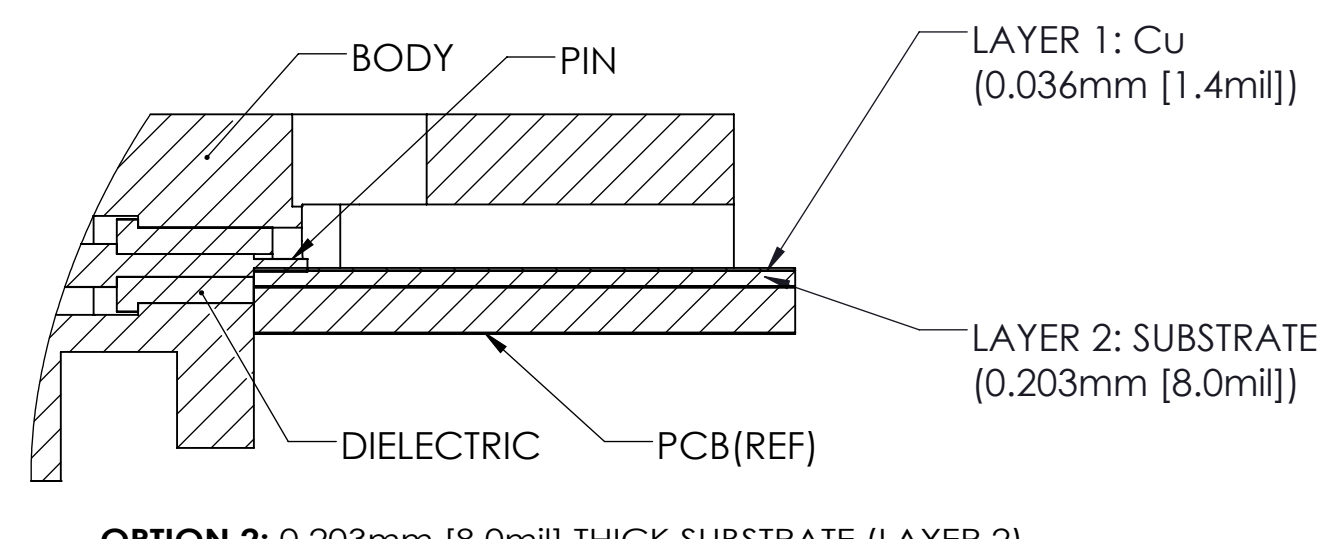

OPTION 2: 0.203mm [8.0mil] THICK SUBSTRATE (LAYER 2)

**Standard PCB LAYOUT**  
(FOR REFERENCE ONLY)

SCALE	SUB-DIRECTORY/		SHEET 2 OF 3
10:1			
SIZE	CAGE CODE	DRAWING NO.	REV.
C		<b>TMB-E4F2-1L1-01</b>	-

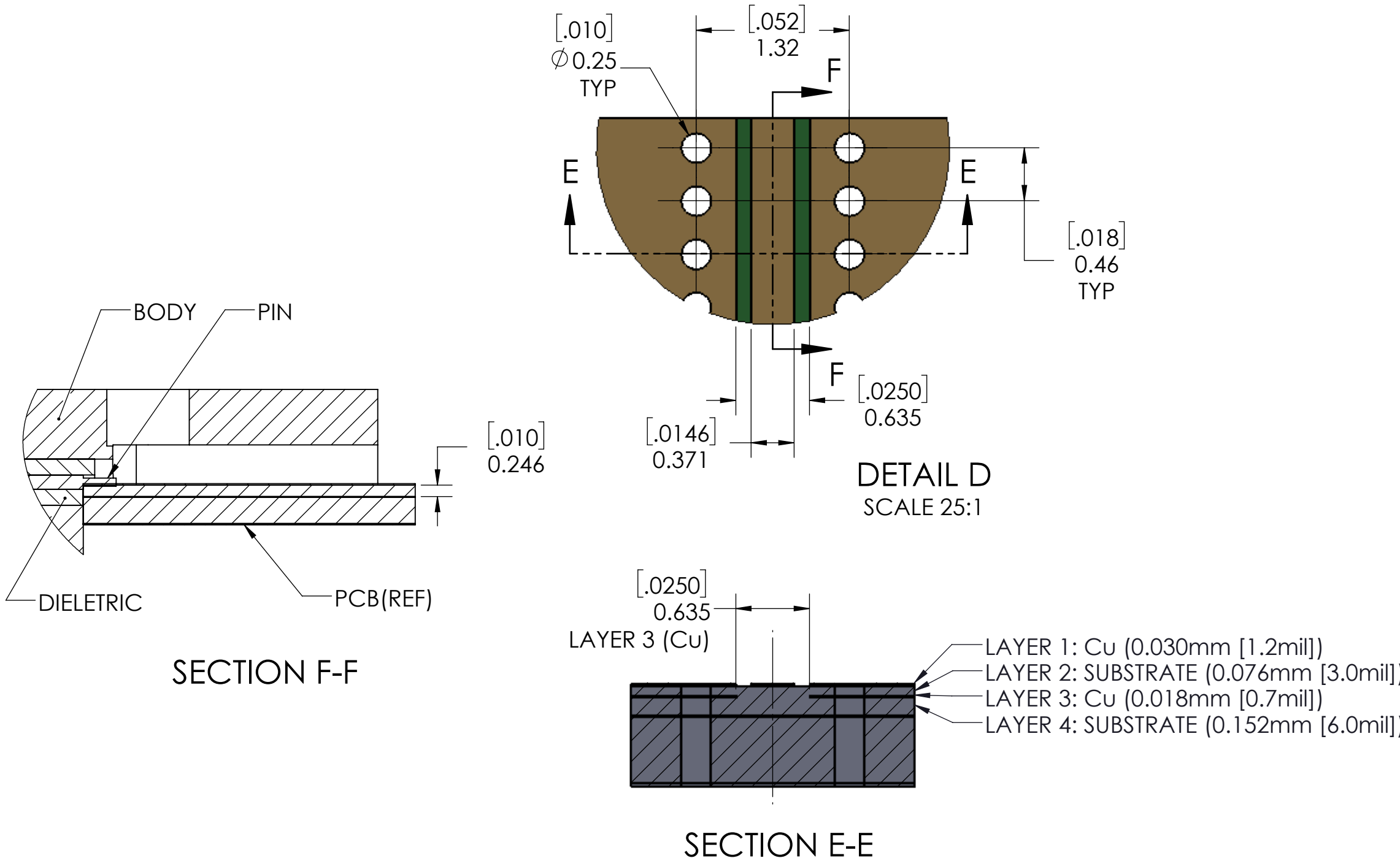

**PCB 9mil Option**  
 0.246mm [9.7mil] Dielectric  
 SUBSTRATE LAYERS 2 AND 4

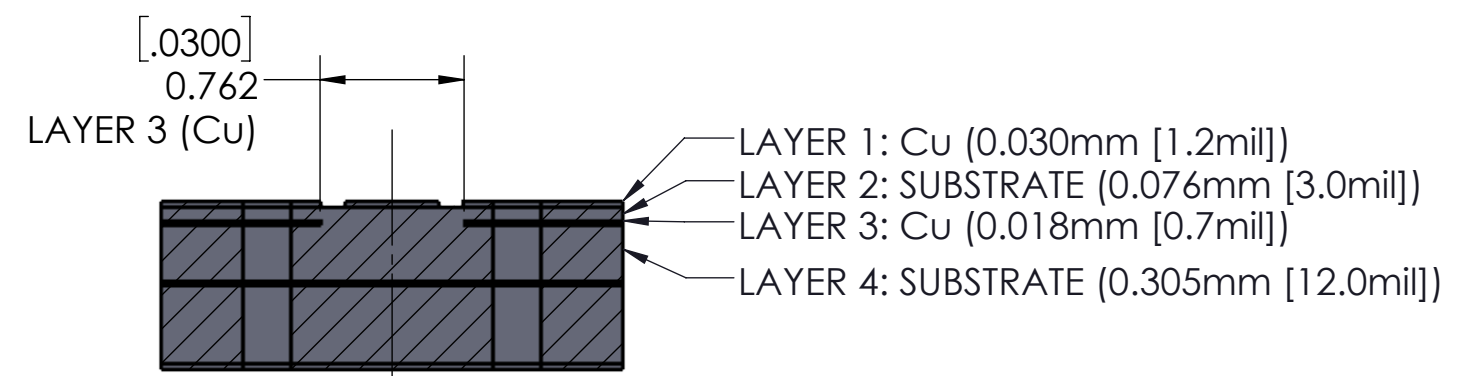
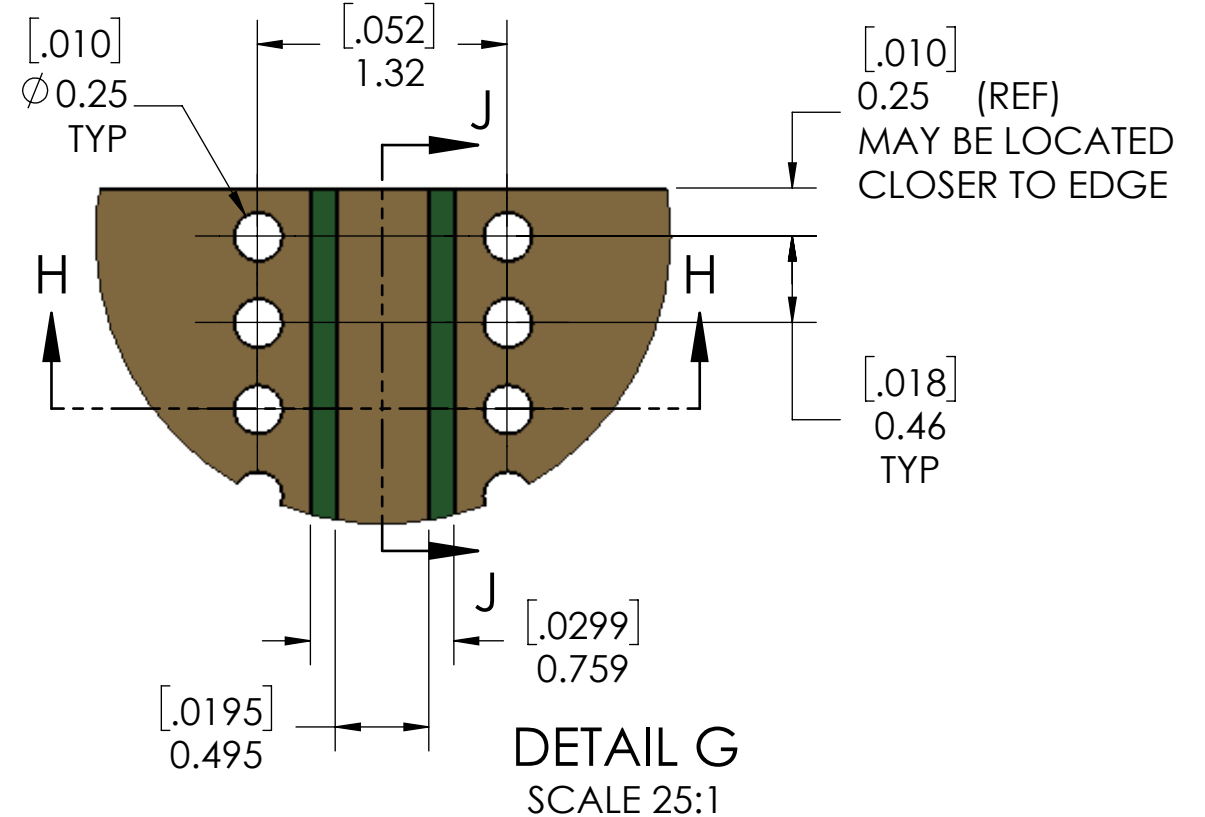
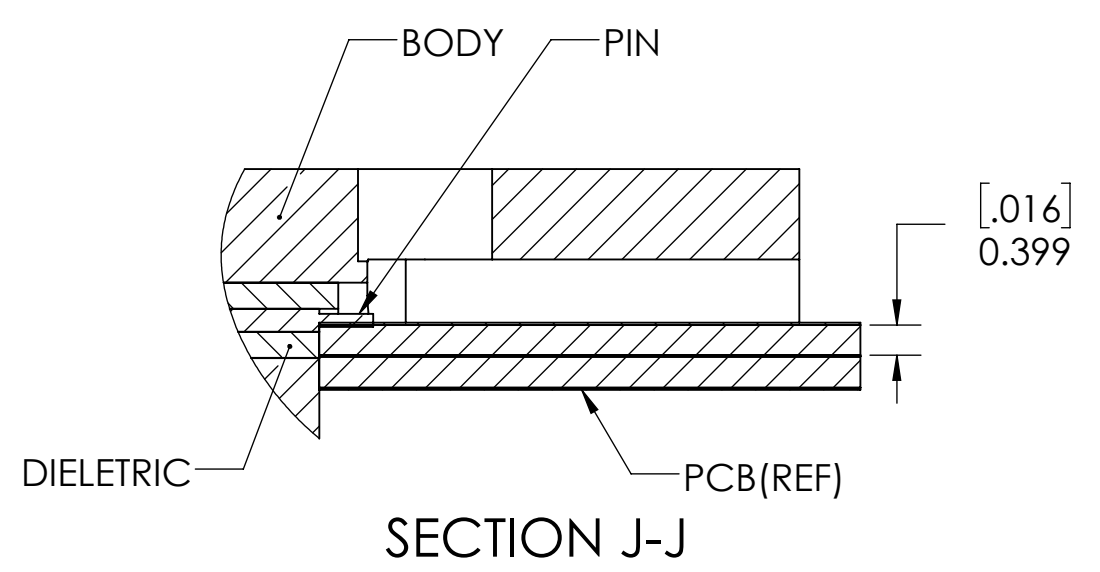

**PCB 15mil Option**  
 0.399mm [15.7mil] Dielectric  
 SUBSTRATE LAYERS 2 AND 4

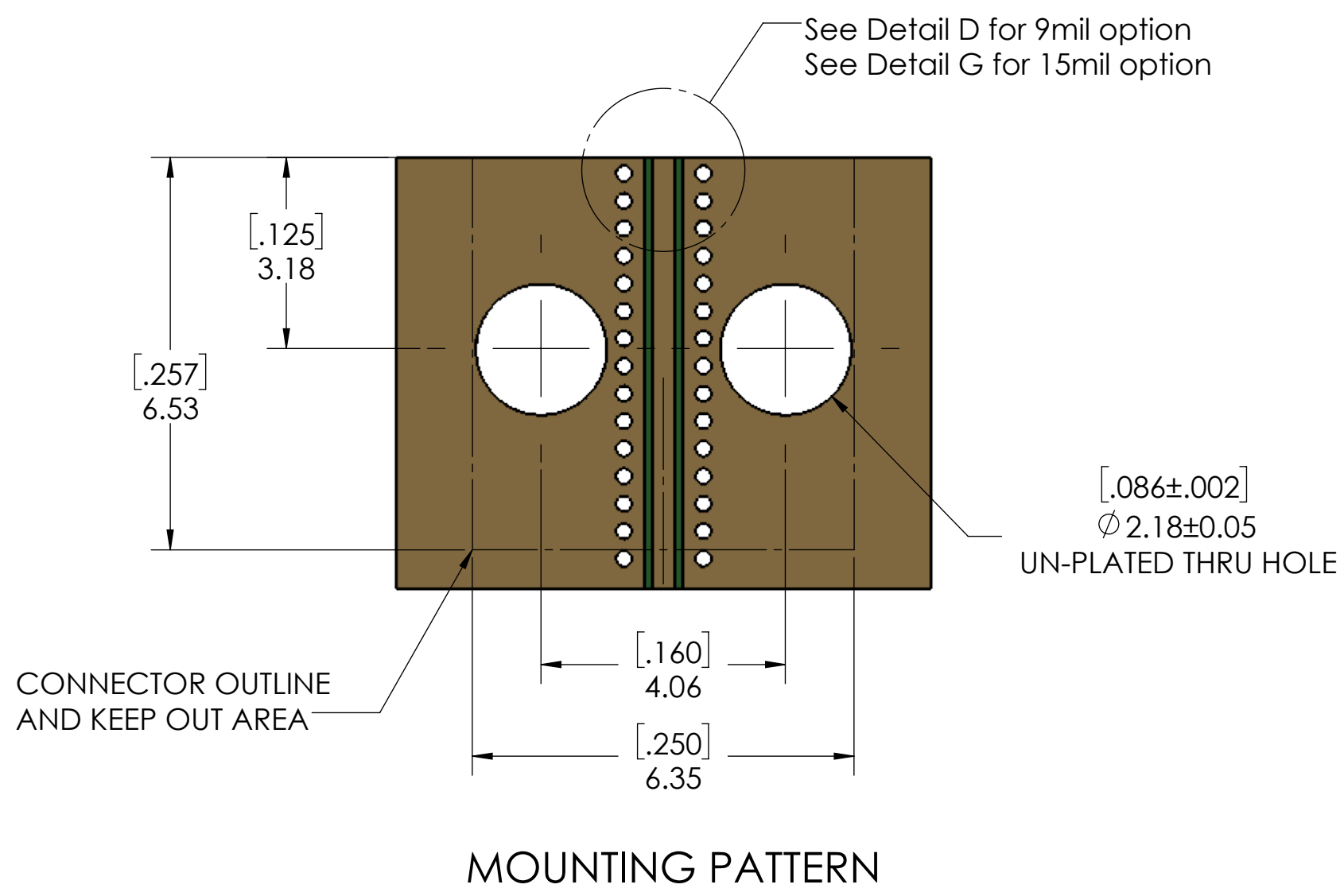

**PCB LAYOUT**  
**Non-standard board stackup**  
**(Reference)**

SCALE	SUB-DIRECTORY/		SHEET 3 OF 3
10:1			
SIZE	CAGE CODE	DRAWING NO.	REV.
C		<b>TMB-E4F2-1L1-01</b>	-