

4 A DC step-down switching regulator

Datasheet — production data

Features

- 4 A DC output current
- 2.8 V to 5.5 V input voltage
- Output voltage adjustable from 0.8 V
- 1.5 MHz switching frequency
- Internal soft-start and enable
- Integrated 60 mΩ and 45 mΩ Power MOSFETs
- All ceramic capacitor
- Power Good (POR)
- Cycle-by-cycle current limiting
- Current foldback short-circuit protection
- VFDFPN 8 4x4x1.0 package

Applications

- μP/ASIC/DSP/FPGA core and I/O supplies
- Point of Load for: STB, TV, DVD
- Optical storage, hard disk drives, printers, audio/graphic cards

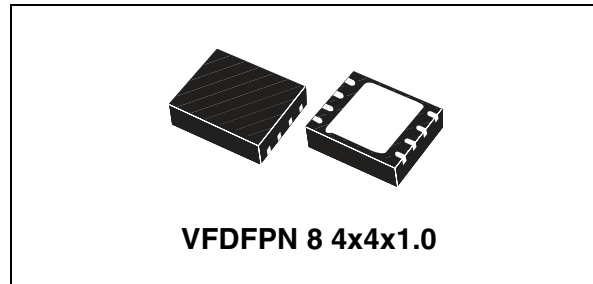

Description

The ST1S32 is an internally compensated 1.5 MHz fixed-frequency PWM synchronous step-down regulator. The ST1S32 operates from 2.8 V to 5.5 V input, while it regulates an output voltage as low as 0.8 V and up to V_{IN} .

The ST1S32 integrates a 60 mΩ high-side switch and a 45 mΩ synchronous rectifier, allowing very high efficiency with very low output voltages.

The peak current mode control with internal compensation delivers a very compact solution with a minimum component count.

The ST1S32 is available in 4 mm x 4 mm, 8-lead VFDFPN package.

Figure 1. Application circuit

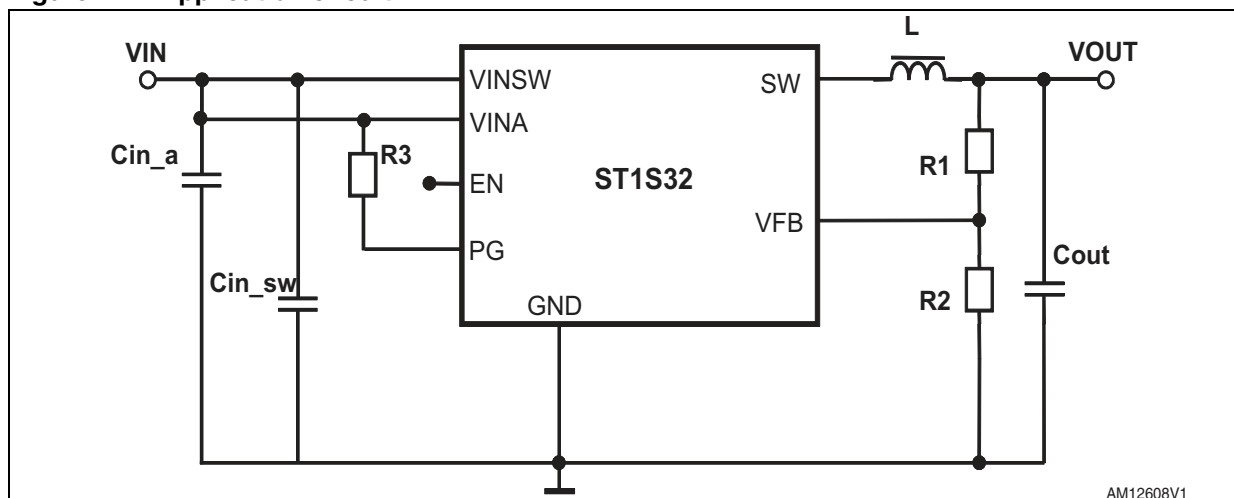

Contents

1	Pin settings	3
1.1	Pin connection	3
1.2	Pin description	3
2	Maximum ratings	4
2.1	Thermal data	4
3	Electrical characteristics	5
4	Functional description	7
4.1	Soft-start	8
4.2	Error amplifier and control loop stability	8
4.3	Overcurrent protection	13
4.4	Enable function	14
4.5	Light load operation	14
4.6	Hysteretic thermal shutdown	14
5	Application information	15
5.1	Input capacitor selection	15
5.2	Inductor selection	16
5.3	Output capacitor selection	17
5.4	Thermal dissipation	18
5.5	Layout considerations	20
6	Demonstration board	22
7	Typical characteristics	24
8	Package mechanical data	26
9	Order codes	28
10	Revision history	28

1 Pin settings

1.1 Pin connection

Figure 2. Pin connection (top view)

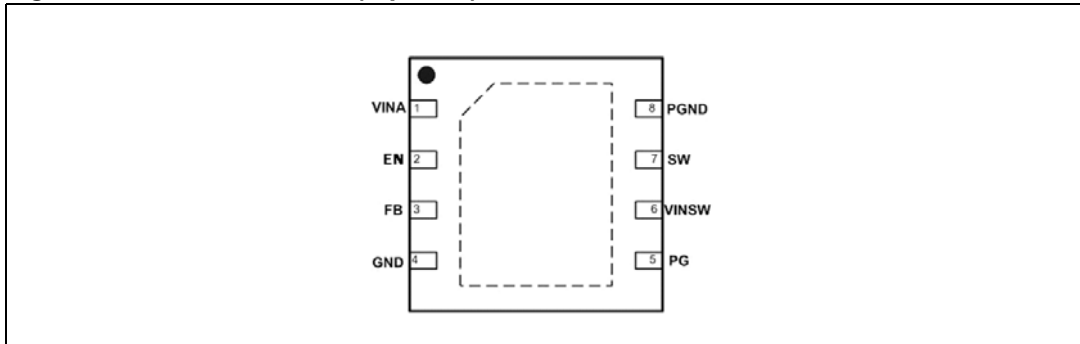

1.2 Pin description

Table 1. Pin description

No.	Type	Description
1	VINA	Unregulated DC input voltage.
2	EN	Enable input. With EN higher than 1.5 V the device in ON and with EN lower than 0.5 V the device is OFF.
3	FB	Feedback input. Connecting the output voltage directly to this pin the output voltage is regulated at 0.8 V. To have higher regulated voltages an external resistor divider is required from V_{OUT} to the FB pin.
4	AGND	Ground.
5	PG	Open drain Power Good (POR) pin. It is released (open drain) when the output voltage is higher than $0.92 * V_{OUT}$ with a delay of 170 us. If the output voltage is below $0.92 * V_{OUT}$, the POR pin goes to low impedance immediately. If not used, it can be left floating or to GND.
6	VINSW	Power input voltage.
7	SW	Regulator output switching pin.
8	PGND	Power Ground.

2 Maximum ratings

Table 2. Absolute maximum ratings

Symbol	Parameter	Value	Unit
V_{IN}	Input voltage	-0.3 to 7	V
V_{EN}	Enable voltage	-0.3 to V_{IN}	
V_{SW}	Output switching voltage	-1 to V_{IN}	
V_{PG}	Power-on reset voltage (Power Good)	-0.3 to V_{IN}	
V_{FB}	Feedback voltage	-0.3 to 1.5	
P_{TOT}	Power dissipation at $T_A < 60\text{ °C}$	2.25	W
T_{OP}	Operating junction temperature range	-40 to 150	°C
T_{stg}	Storage temperature range	-55 to 150	°C

2.1 Thermal data

Table 3. Thermal data

Symbol	Parameter	Value	Unit
R_{thJA}	Maximum thermal resistance junction-ambient ⁽¹⁾	40	°C/W

1. Package mounted on demonstration board.

3 Electrical characteristics

$T_J=25\text{ }^\circ\text{C}$, $V_{IN}=5\text{ V}$, unless otherwise specified.

Table 4. Electrical characteristics

Symbol	Parameter	Test condition	Values			Unit
			Min.	Typ.	Max.	
V_{IN}	Operating input voltage range	(1)	2.8		5.5	V
V_{INON}	Turn-on V_{CC} threshold	(1)		2.4		
V_{INOFF}	Turn-off V_{CC} threshold	(1)		2.0		
R_{DSON-P}	High-side switch on-resistance	$I_{SW}=300\text{ mA}$		60		$\text{m}\Omega$
R_{DSON-N}	Low-side switch on-resistance	$I_{SW}=300\text{ mA}$		45		$\text{m}\Omega$
I_{LIM}	Maximum limiting current	(2)	5.0			A
Oscillator						
F_{SW}	Switching frequency		1.2	1.5	1.9	MHz
D_{MAX}	Maximum duty cycle	(2)	95		100	%
Dynamic characteristics						
V_{FB}	Feedback voltage		0.792	0.8	0.808	V
		$I_O=10\text{ mA to }4\text{ A}^{(1)}$	0.776	0.8	0.824	
$\%V_{OUT}/\Delta I_{OUT}$	Reference load regulation	$I_O=10\text{ mA to }4\text{ A}^{(2)}$		0.2	0.6	%
$\%V_{OUT}/\Delta V_{IN}$	Reference line regulation	$V_{IN}=2.8\text{ V to }5.5\text{ V}^{(2)}$		0.2	0.3	%
DC characteristics						
I_Q	Quiescent current	Duty cycle=0, no load $V_{FB}=1.2\text{ V}$		630	1200	μA
I_{QST-BY}	Total standby quiescent current	OFF			10	μA
Enable						
V_{EN}	EN threshold voltage	Device ON level	1.5			V
		Device OFF level			0.5	
I_{EN}	EN current				0.1	μA

Table 4. Electrical characteristics (continued)

Symbol	Parameter	Test condition	Values			Unit
			Min.	Typ.	Max.	
Power Good						
PG	PG threshold			92		%V _{FB}
	PG hysteresis		30	50		mV
	PG output voltage low	I _{sink} = 6 mA open drain			400	
	PG rise delay			170		μs
Soft-start						
T _{SS}	Soft-start duration			400		μs
Protection						
T _{SHDN}	Thermal shutdown			150		°C
	Hysteresis			20		

1. Specifications referred to T_J from -40 to +125 °C. Specifications in the -40 to +125 °C temperature range are assured by design, characterization and statistical correlation.

2. Guaranteed by design.

4.1 Soft-start

The soft-start is essential to assure the correct and safe startup of the step-down converter. It avoids inrush current surge and makes the output voltage rise monotonically.

The soft-start is managed by ramping the reference of the error amplifier from 0 V to 0.8 V. The internal soft-start capacitor is charged with a resistor to 0.8 V, then the FB pin follows the reference so that the output voltage is regulated to rise to the set value monotonically.

4.2 Error amplifier and control loop stability

The error amplifier provides the error signal to be compared with the high-side switch current through the current sense circuitry. The non-inverting input is connected with the internal 0.8 V reference, whilst the inverting input is the FB pin. The compensation network is internal and connected between the E/A output and GND.

The error amplifier of the ST1S32 is a transconductance operational amplifier, with high bandwidth and high output impedance.

The characteristics of the uncompensated error amplifier are:

Table 5. Characteristics of the uncompensated error amplifier

Description	Value
DC gain	94 dB
gm	238 μ A/V
Ro	96 M Ω

The ST1S32 embeds the compensation network that assures the stability of the loop in the whole operating range. Here below are all the tools needed to check the loop stability.

In [Figure 4](#), the simple small signal model for the peak current mode control loop is shown.

Figure 4. Block diagram of the loop for the small signal analysis

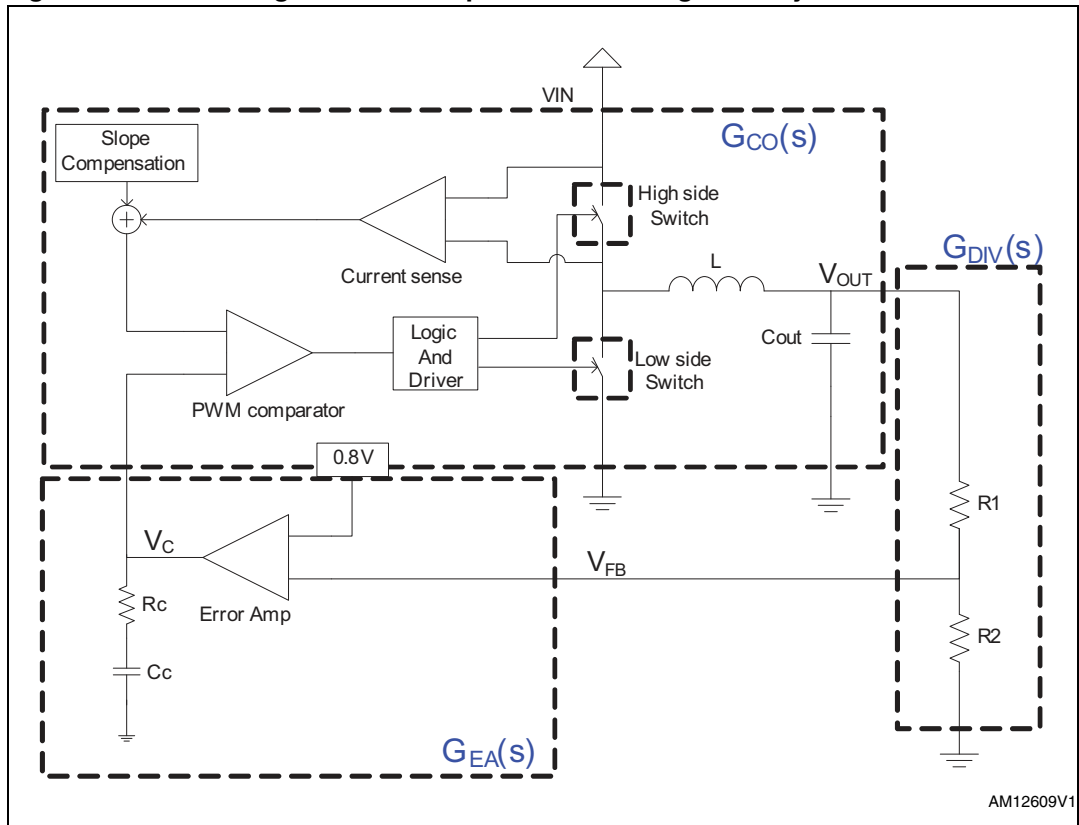

Three main terms can be identified to obtain the loop transfer function:

1. from control (output of E/A) to output, $G_{CO}(s)$;
2. from output (V_{OUT}) to the FB pin, $G_{DIV}(s)$;
3. from the FB pin to control (output of E/A), $G_{EA}(s)$.

The transfer function from control to output $G_{CO}(s)$ results:

Equation 1

$$G_{CO}(s) = \frac{R_{LOAD}}{R_i} \cdot \frac{1}{1 + \frac{R_{out} \cdot T_{SW}}{L} \cdot [m_C \cdot (1 - D) - 0.5]} \cdot \frac{\left(1 + \frac{s}{\omega_z}\right)}{\left(1 + \frac{s}{\omega_p}\right)} \cdot F_H(s)$$

where R_{LOAD} represents the load resistance, R_i the equivalent sensing resistor of the current sense circuitry (0.369Ω), ω_p the single pole introduced by the LC filter and ω_z the zero given by the ESR of the output capacitor.

$F_H(s)$ accounts for the sampling effect performed by the PWM comparator on the output of the error amplifier that introduces a double pole at one half of the switching frequency.

Equation 2

$$\omega_z = \frac{1}{ESR \cdot C_{OUT}}$$

Equation 3

$$\omega_p = \frac{1}{R_{LOAD} \cdot C_{OUT}} + \frac{m_C \cdot (1-D) - 0.5}{L \cdot C_{OUT} \cdot f_{SW}}$$

where:

Equation 4

$$\begin{cases} m_C = 1 + \frac{S_e}{S_n} \\ S_e = V_{pp} \cdot f_{SW} \\ S_n = \frac{V_{IN} - V_{OUT}}{L} \cdot R_i \end{cases}$$

S_n represents the ON-time slope of the sensed inductor current, S_e the slope of the external ramp (V_{pp} peak-to-peak amplitude - 0.535 V) that implements the slope compensation to avoid sub-harmonic oscillations at duty cycle over 50%.

The sampling effect contribution $F_H(s)$ is:

Equation 5

$$F_H(s) = \frac{1}{1 + \frac{s}{\omega_h \cdot Q_P} + \frac{s^2}{\omega_h^2}}$$

where:

Equation 6

$$Q_P = \frac{1}{\pi \cdot [m_C \cdot (1-D) - 0.5]}$$

and

Equation 7

$$\omega_h = \pi \cdot f_{SW}$$

The transfer function $G_{DIV}(s)$ from V_{OUT} to FB results:

$$G_{DIV}(s) = \frac{R_2}{R_1 + R_2}$$

The transfer function from FB to V_c (output of E/A) introduces the singularities (poles and zeroes) to stabilize the loop. In [Figure 5](#), the small signal model of the error amplifier with the internal compensation network is shown.

Figure 5. Small signal model for the error amplifier

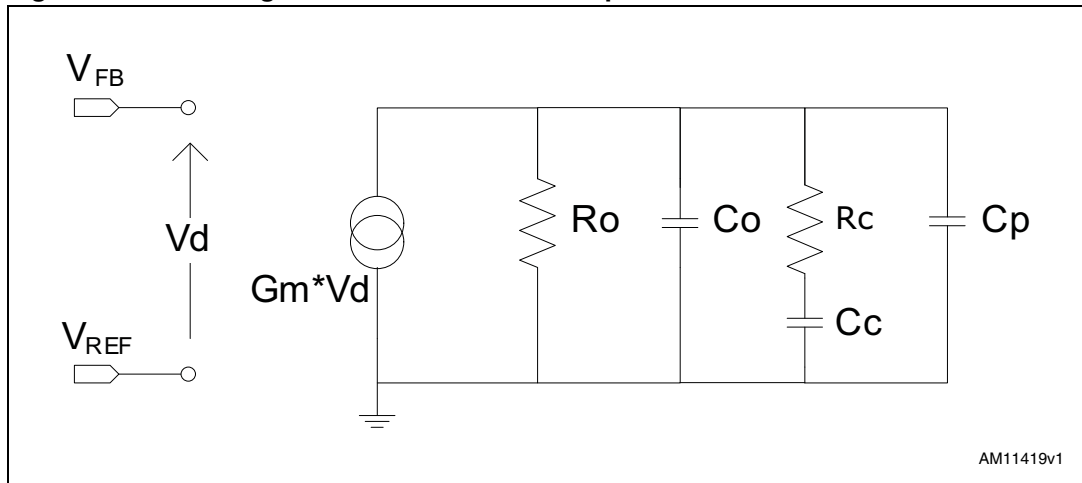

R_C and C_C introduce a pole and a zero in the open loop gain. C_P does not significantly affect system stability and can be neglected.

So, $G_{EA}(s)$ results:

Equation 8

$$G_{EA}(s) = \frac{G_{EA0} \cdot (1 + s \cdot R_C \cdot C_C)}{s^2 \cdot R_O \cdot (C_O + C_P) \cdot R_C \cdot C_C + s \cdot (R_O \cdot C_C + R_O \cdot (C_O + C_P) + R_C \cdot C_C) + 1}$$

where $G_{EA} = G_m \cdot R_O$

The poles of this transfer function are (if $C_C \gg C_O + C_P$):

Equation 9

$$f_{P_{LF}} = \frac{1}{2 \cdot \pi \cdot R_O \cdot C_C}$$

Equation 10

$$f_{P_{HF}} = \frac{1}{2 \cdot \pi \cdot R_C \cdot (C_O + C_P)}$$

whereas the zero is defined as:

Equation 11

$$f_Z = \frac{1}{2 \cdot \pi \cdot R_C \cdot C_C}$$

The embedded compensation network is $R_C=80 \text{ k}\Omega$, $C_C=55 \text{ pF}$ while C_P and C_O can be considered as negligible. The error amplifier output resistance is $212 \text{ M}\Omega$, so the relevant singularities are:

Equation 12

$$f_z = 36, 2 \text{ kHz} \quad f_{p_{LF}} = 30 \text{ Hz}$$

So, closing the loop, the loop gain $G_{LOOP}(s)$ is:

Equation 13

$$G_{LOOP}(s) = G_{CO}(s) \cdot G_{DIV}(s) \cdot G_{EA}(s)$$

Example:

$V_{IN}=5 \text{ V}$, $V_{OUT}=1.2 \text{ V}$, $I_{max}=4 \text{ A}$, $L=1.0 \text{ uH}$, $C_{out}=47 \text{ uF (MLCC)}$, $R1=10 \text{ k}\Omega$ $R2=20 \text{ k}\Omega$ (see [Section 5.2](#) and [Section 5.3](#) for inductor and output capacitor selection guidelines).

The module and phase Bode plot are reported in [Figure 6](#).

The bandwidth is 117 kHz and the phase margin is 63 degrees.

Figure 6. Module Bode plot

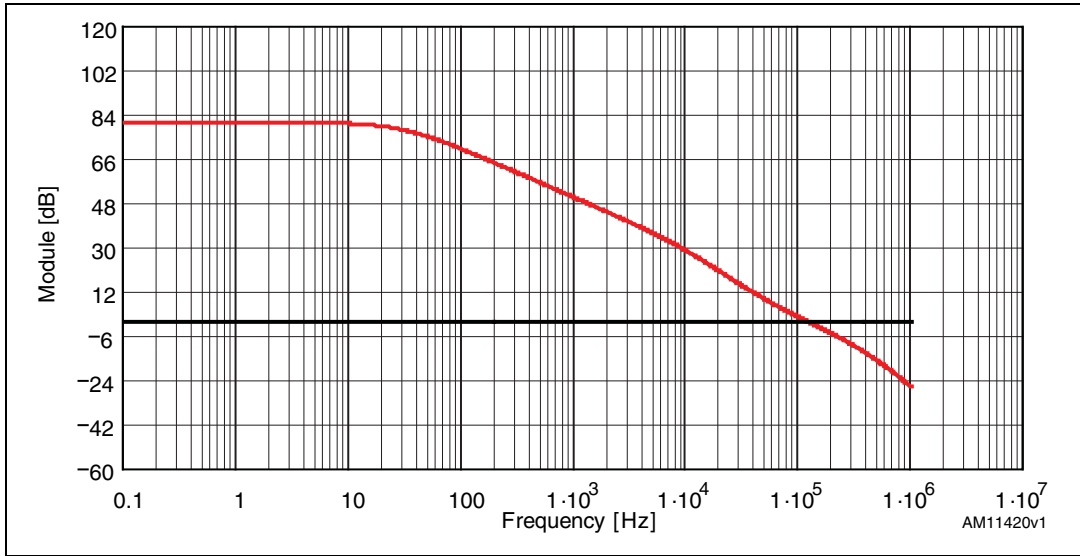
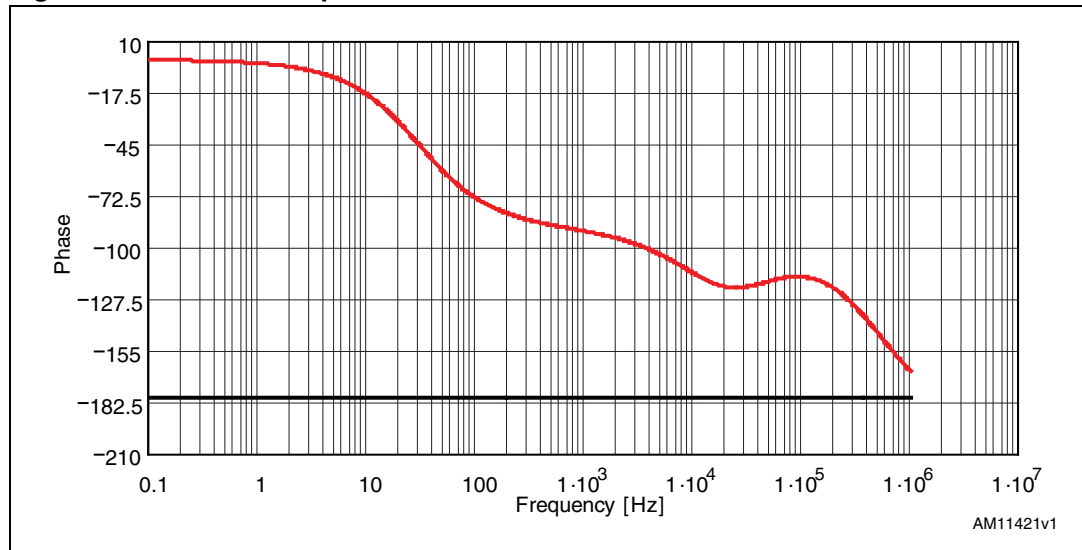

Figure 7. Phase Bode plot



4.3 Overcurrent protection

The ST1S32 implements overcurrent protection sensing the current flowing through the high-side current switch.

If the current exceeds the overcurrent threshold, the high-side is turned off, implementing a cycle-by-cycle current limitation. Since the regulation loop is no longer fixing the duty cycle, the output voltage is unregulated and the FB pin falls accordingly to the new duty cycle.

If the FB pin falls below 0.2 V, the peak current limit is reduced to around 2.3 A and the switching frequency is reduced to assure that the inductor current is properly limited below the above mentioned value and above 1.2 A. This strategy is called “current foldback”.

The mechanism to adjust the switching undercurrent foldback condition exploits the low-side current sense circuitry. If FB is lower than 0.2 V, the high-side Power MOSFET is turned off when the current reaches the current foldback threshold (2.3 A), then, after a proper dead time that avoids the cross conduction, the low-side is turned on until the low-side current is lower than a valley threshold (1.2 A). Once the low-side is turned off, the high-side is immediately turned on. In this way the frequency is adjusted to keep the inductor current ripple between the current foldback value (2.3 A) and valley threshold (1.2 A), therefore properly limiting the output current in case of overcurrent or short-circuit.

It should be noted that in some cases, mainly with very low output voltages, the hard overcurrent can make the FB find the new equilibrium just over the current foldback threshold (0.2 V). In this case no frequency reduction is enabled, then the inductor current may diverge. That is, the ripple current during the minimum ON-time is higher than the ripple current during the OFF-time (the switching period minus the minimum ON-time), so pulse-by-pulse the average current is rising, exceeding the current limit.

In order to avoid too high current, a further protection is activated when the high-side current exceeds a further current threshold (OCP2) slightly over the current limit (OCP1). If the current triggers the second threshold, the converter stops switching, the reference of the error amplifier is pulled down and then it restarts with a soft-start procedure. If the overcurrent condition is still active, the current foldback with frequency reduction properly limits the output current to 2.3 A.

4.4 Enable function

The enable feature allows the device to be put into standby mode. With the EN pin lower than 0.4 V, the device is disabled and the power consumption is reduced to less than 10 μ A. With the EN pin higher than 1.2 V, the device is enabled. If the EN pin is left floating, an internal pull-down ensures that the voltage at the pin reaches the inhibit threshold and the device is disabled. The pin is also V_{IN} compatible.

4.5 Light load operation

With peak current mode control loop the output of the error amplifier is proportional to the load current. In the ST1S32, to increase light load efficiency, when the output of the error amplifier falls below a certain threshold, the high-side turn-on is prevented.

This mechanism reduces the switching frequency at light load in order to save the switching losses.

4.6 Hysteretic thermal shutdown

The thermal shutdown block generates a signal that turns off the power stage if the junction temperature goes above 150 °C. Once the junction temperature goes back to about 130 °C, the device restarts in normal operation.

5 Application information

5.1 Input capacitor selection

The capacitor connected to the input must be capable of supporting the maximum input operating voltage and the maximum RMS input current required by the device. The input capacitor is subject to a pulsed current, the RMS value of which is dissipated over its ESR, affecting the overall system efficiency.

So the input capacitor must have an RMS current rating higher than the maximum RMS input current and an ESR value compliant with the expected efficiency.

The maximum RMS input current flowing through the capacitor can be calculated as:

Equation 14

$$I_{RMS} = I_O \cdot \sqrt{D - \frac{2 \cdot D^2}{\eta} + \frac{D^2}{\eta^2}}$$

where I_O is the maximum DC output current, D is the duty cycle, and η is the efficiency. Considering $\eta=1$, this function has a maximum at $D=0.5$ and is equal to $I_O/2$.

The peak-to-peak voltage across the input capacitor can be calculated as:

Equation 15

$$V_{PP} = \frac{I_O}{C_{IN} \cdot F_{SW}} \cdot \left[\left(1 - \frac{D}{\eta}\right) \cdot D + \frac{D}{\eta} \cdot (1 - D) \right] + ESR \cdot I_O$$

where ESR is the equivalent series resistance of the capacitor.

Given the physical dimension, ceramic capacitors can well meet the requirements of the input filter sustaining a higher input RMS current than electrolytic / tantalum types. In this case, the equation of C_{IN} as a function of the target peak-to-peak voltage ripple (V_{PP}) can be written as follows:

Equation 16

$$C_{IN} = \frac{I_O}{V_{PP} \cdot F_{SW}} \cdot \left[\left(1 - \frac{D}{\eta}\right) \cdot D + \frac{D}{\eta} \cdot (1 - D) \right]$$

neglecting the small ESR of ceramic capacitors.

Considering $\eta=1$, this function has its maximum in $D=0.5$, therefore, given the maximum peak-to-peak input voltage (V_{PP_MAX}), the minimum input capacitor (C_{IN_MIN}) value is:

Equation 17

$$C_{IN_MIN} = \frac{I_O}{2 \cdot V_{PP_MAX} \cdot F_{SW}}$$

Typically, C_{IN} is dimensioned to keep the maximum peak-to-peak voltage ripple in the order of 1% of V_{INMAX} .

The placement of the input capacitor is very important in order to avoid noise injection and voltage spikes on the input voltage pin. So the C_{IN} must be placed as close as possible to the VIN_SW pin.

In [Table 6](#) some multi-layer ceramic capacitors suitable for this device are reported.

Table 6. Input MLCC capacitors

Manufacturer	Series	Cap value (μF)	Rated voltage (V)
Murata	GRM21	10	10
TDK	C3225	10	25
	C3216	10	16
Taiyo Yuden	LMK212	22	10

A ceramic bypass capacitor, as close as possible to the $VINA$ pin, so that additional parasitic ESR and ESL are minimized, is suggested in order to prevent instability on the output voltage due to noise. The value of the bypass capacitor can go from 330 nF to 1 μF .

5.2 Inductor selection

The inductance value fixes the current ripple flowing through the output capacitor. So the minimum inductance value in order to have the expected current ripple must be selected. The rule to fix the current ripple value is to have a ripple at 20%-40% of the output current.

In continuous current mode (CCM), the inductance value can be calculated by the following equation:

Equation 18

$$\Delta I_L = \frac{V_{IN} - V_{OUT}}{L} \cdot T_{ON} = \frac{V_{OUT}}{L} \cdot T_{OFF}$$

where T_{ON} is the conduction time of the high-side switch and T_{OFF} is the conduction time of the low-side switch (in CCM, $F_{SW} = 1/(T_{ON} + T_{OFF})$). The maximum current ripple, given the V_{OUT} , is obtained at maximum T_{OFF} , that is at minimum duty cycle (see previous section to calculate minimum duty). So by fixing $\Delta I_L = 20\%$ to 30% of the maximum output current, the minimum inductance value can be calculated as:

Equation 19

$$L_{MIN} = \frac{V_{OUT}}{\Delta I_{MAX}} \cdot \frac{1 - D_{MIN}}{F_{SWMIN}}$$

where F_{SWMIN} is the minimum switching frequency, according to [Table 4](#).

The slope compensation, to prevent the sub-harmonic instability in peak current control loop, is internally managed and so fixed. This implies a further lower limit for the inductor value. To assure the sub-harmonic stability:

Equation 20

$$L > V_{\text{out}} / (2 \cdot V_{\text{pp}} \cdot f_{\text{sw}})$$

where V_{pp} is the peak-to-peak value of the slope compensation ramp.

The inductor value selected, based on [Equation 19](#), must satisfy [Equation 20](#).

The peak current through the inductor is given by:

Equation 21

$$I_{L, \text{PK}} = I_{\text{O}} + \frac{\Delta I_{\text{L}}}{2}$$

So if the inductor value decreases, the peak current (that must be lower than the current limit of the device) increases. The higher the inductor value, the higher the average output current that can be delivered, without reaching the current limit.

In [Table 7](#) some inductor part numbers are listed.

Table 7. Inductors

Manufacturer	Series	Inductor value (μH)	Saturation current (A)
Coilcraft	XAL50xx	1.2 to 3.3	6.3 to 9
	XAL60xx	2.2 to 5.6	7.4 to 11
	MSS1048	1.0 to 3.8	6.5 to 11
Würth	WE-HCI 7030	1.5 to 4.7	7 to 14
	WE-PD type L	1.5 to 3.5	6.4 to 10
Coiltronics	DR73	1.0 to 2.2	5.5 to 7.9
	DR74	1.5 to 3.3	5.4 to 8.35

5.3 Output capacitor selection

The current in the output capacitor has a triangular waveform which generates a voltage ripple across it. This ripple is due to the capacitive component (charge or discharge of the output capacitor) and the resistive component (due to the voltage drop across its ESR). So the output capacitor must be selected in order to have a voltage ripple compliant with the application requirements.

The amount of the voltage ripple can be calculated starting from the current ripple obtained by the inductor selection.

Equation 22

$$\Delta V_{OUT} = ESR \cdot \Delta I_{MAX} + \frac{\Delta I_{MAX}}{8 \cdot C_{OUT} \cdot f_{SW}}$$

For the ceramic (MLCC) capacitor the capacitive component of the ripple dominates the resistive one. While for the electrolytic capacitor the opposite is true.

As the compensation network is internal, the output capacitor should be selected in order to have a proper phase margin and then a stable control loop.

The equations of [Section 4.2](#) help to check loop stability, given the application conditions, the value of the inductor and the output capacitor.

In [Table 8](#) some capacitor series are listed.

Table 8. Output capacitors

Manufacturer	Series	Cap value (μF)	Rated voltage (V)	ESR (mΩ)
Murata	GRM32	22 to 100	6.3 to 25	< 5
	GRM31	10 to 47	6.3 to 25	< 5
Panasonic	ECJ	10 to 22	6.3	< 5
	EEFCD	10 to 68	6.3	15 to 55
Sanyo	TPA/B/C	100 to 470	4 to 16	40 to 80
TDK	C3225	22 to 100	6.3	< 5

5.4 Thermal dissipation

The thermal design is important to prevent the thermal shutdown of the device if junction temperature goes above 150 °C. The three different sources of loss within the device are:

- a) conduction losses due to the on-resistance of the high-side switch (R_{HS}) and low-side switch (R_{LS}); these are equal to:

Equation 23

$$P_{COND} = R_{HS} \cdot I_{OUT}^2 \cdot D + R_{LS} \cdot I_{OUT}^2 \cdot (1 - D)$$

where D is the duty cycle of the application. Note that the duty cycle is theoretically given by the ratio between V_{OUT} and V_{IN} , but actually it is slightly higher to compensate the losses of the regulator.

- b) switching losses due to high-side Power MOSFET turn-on and off; these can be calculated as:

Equation 24

$$P_{SW} = V_{IN} \cdot I_{OUT} \cdot \frac{(T_{RISE} + T_{FALL})}{2} \cdot F_{SW} = V_{IN} \cdot I_{OUT} \cdot T_{SW} \cdot F_{SW}$$

where T_{RISE} and T_{FALL} are the overlap times of the voltage across the high-side power switch (V_{DS}) and the current flowing into it during turn-on and turn-off phases, as shown in [Figure 8](#). T_{SW} is the equivalent switching time. For this device the typical value for the equivalent switching time is 20 ns.

- c) Quiescent current losses, calculated as:

Equation 25

$$P_Q = V_{IN} \cdot I_Q$$

where I_Q is the quiescent current ($I_Q=1.2$ mA maximum).

The junction temperature T_J can be calculated as:

Equation 26

$$T_J = T_A + R_{thJA} \cdot P_{TOT}$$

where T_A is the ambient temperature and P_{TOT} is the sum of the power losses just seen.

R_{thJA} is the equivalent thermal resistance junction-to-ambient of the device; it can be calculated as the parallel of many paths of heat conduction from the junction to the ambient. For this device the path through the exposed pad is the one conducting the largest amount of heat. The R_{thJA} measured on the demonstration board described in [Section 5.5](#) is about 40 °C/W for the VFDFPN package.

Figure 8. Switching losses

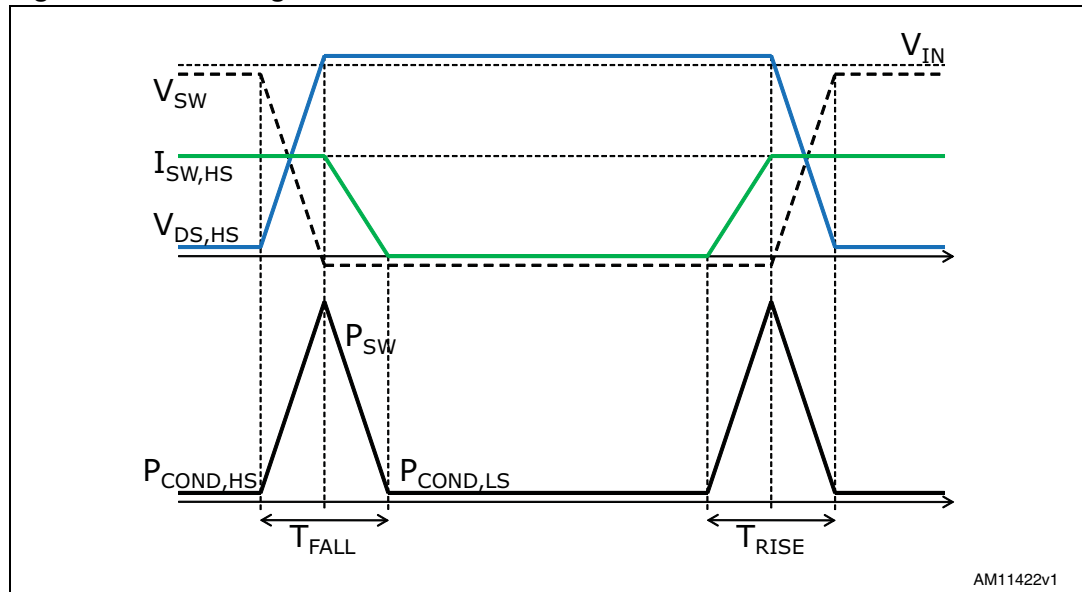

5.5 Layout considerations

The PC board layout of the switching DC/DC regulator is very important to minimize the noise injected in high impedance nodes, to reduce interference generated by the high switching current loops and to optimize the reliability of the device.

In order to avoid EMC problems, the high switching current loops must be as short as possible. In the buck converter there are two high switching current loops: during the ON-time, the pulsed current flows through the input capacitor, the high-side power switch, the inductor and the output capacitor; during the OFF-time, through the low-side power switch, the inductor and the output capacitor.

The input capacitor connected to V_{IN}SW must be placed as close as possible to the device, to avoid spikes on V_{IN}SW due to the stray inductance and the pulsed input current.

In order to prevent dynamic unbalance between V_{IN}SW and V_{INA}, the trace connecting the V_{INA} pin to the input must be derived from V_{IN}SW.

The feedback pin (FB) connection to the external resistor divider is a high impedance node, so interference can be minimized by routing the feedback node with a very short trace and as far as possible from the high current paths.

A single point connection from signal ground to power ground is suggested.

Thanks to the exposed pad of the device, the ground plane helps to reduce the thermal resistance junction-to-ambient; so a large ground plane, soldered to the exposed pad, enhances the thermal performance of the converter allowing high power conversion.

Figure 9. PCB layout example

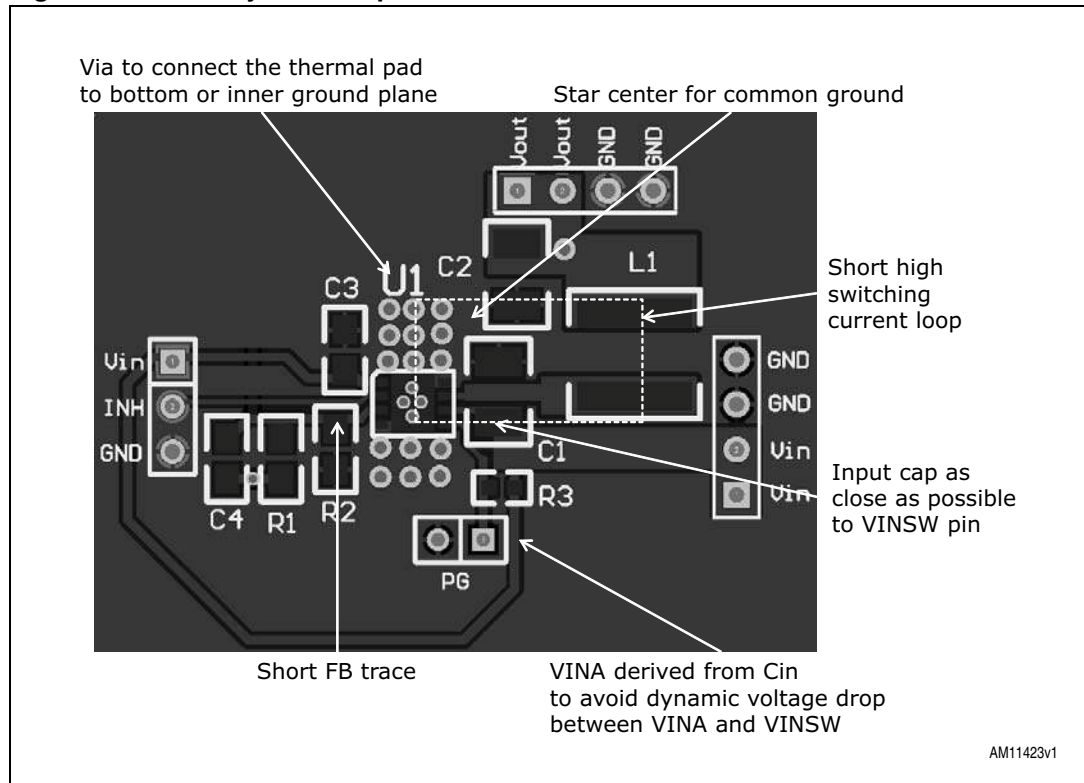

6 Demonstration board

Figure 10. Demonstration board schematic

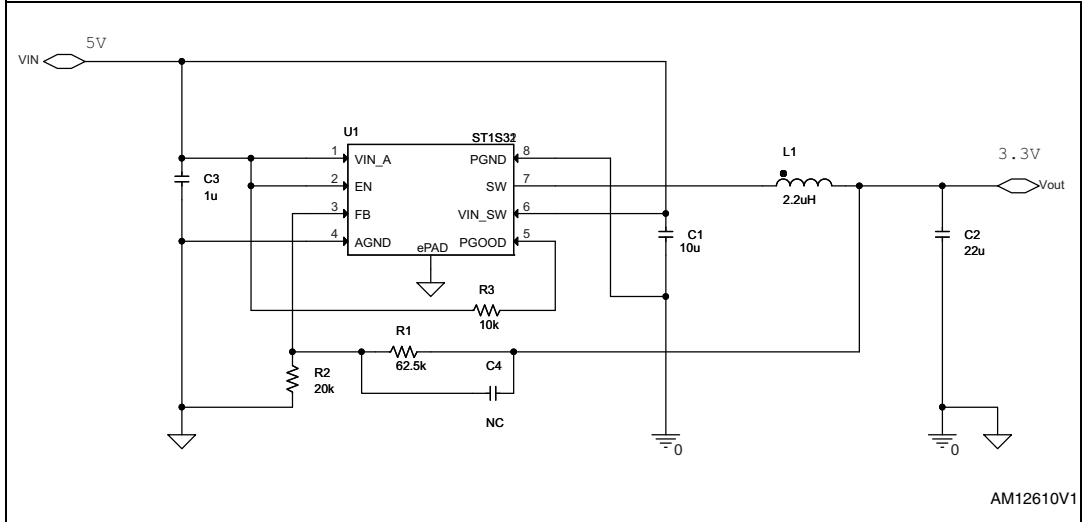
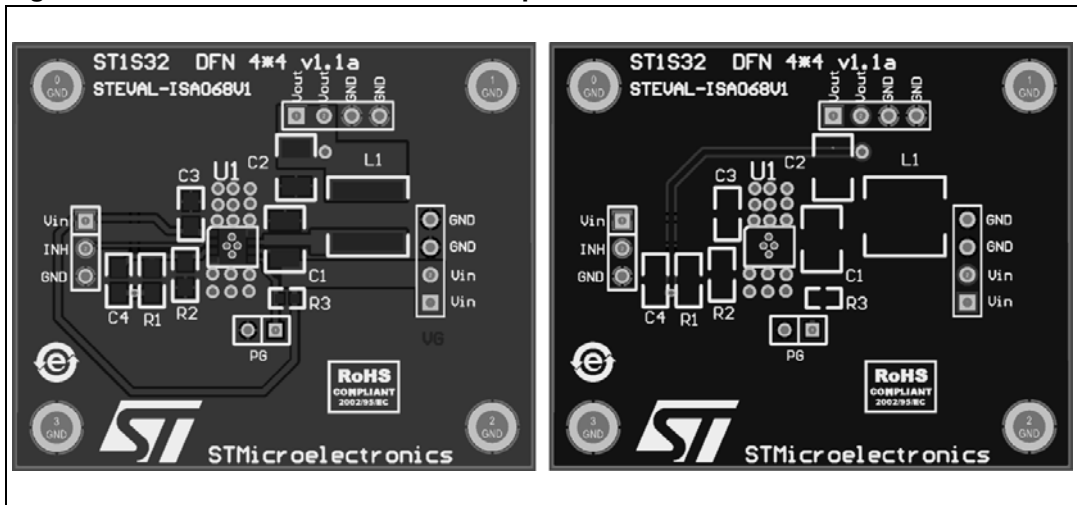

Table 9. Component list

Reference	Part number	Description	Manufacturer
U1	ST1S32PUR		ST
L1	DR74 2R2	2.2 µH, Isat=7 A	Coiltronics
C1	C3225X7RE106K	10 µF 25 V X7R	TDK
C2	C3225X7R1C226M	22 µF 16 V X7R	TDK
C3		1 µF 25 V X7R	
C4		NC	
R1		62.5 kΩ	
R2		20 kΩ	
R3		10 kΩ	

Figure 11. Demonstration board PCB top and bottom



7 Typical characteristics

Figure 12. Efficiency vs. I_{OUT} @ $V_{IN} = 5V$

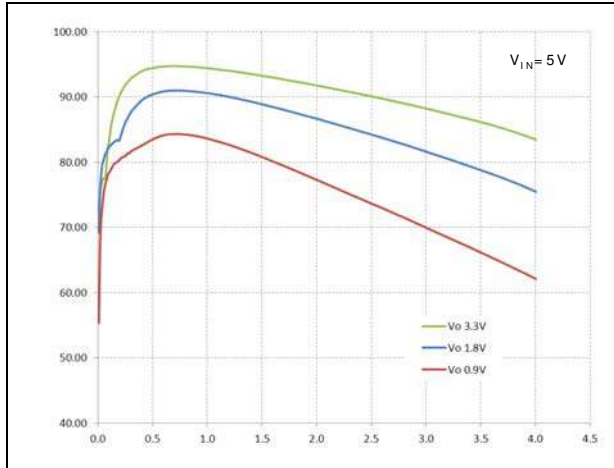

Figure 13. Zero load operation

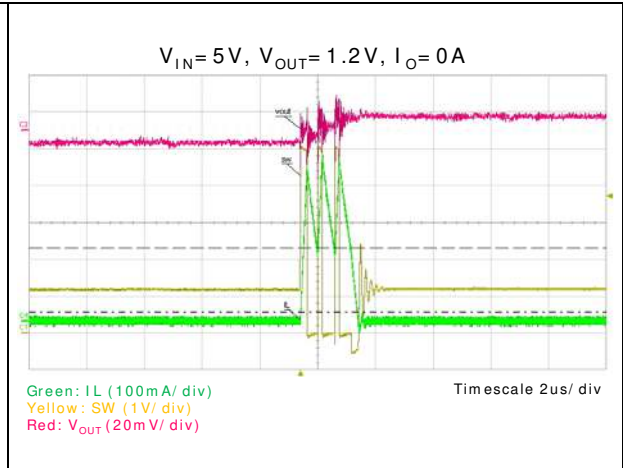

Figure 14. 100 mA operation

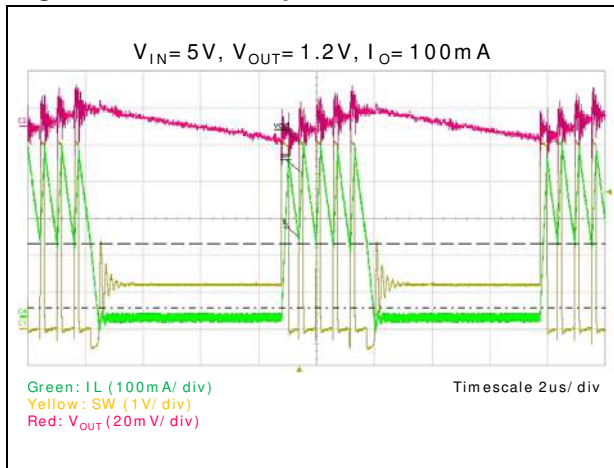

Figure 15. Efficiency vs. I_{OUT} @ $V_{IN} = 3.3V$

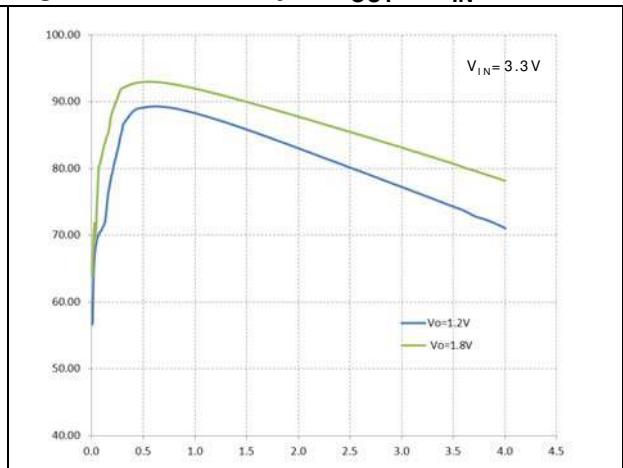

Figure 16. Overcurrent protection

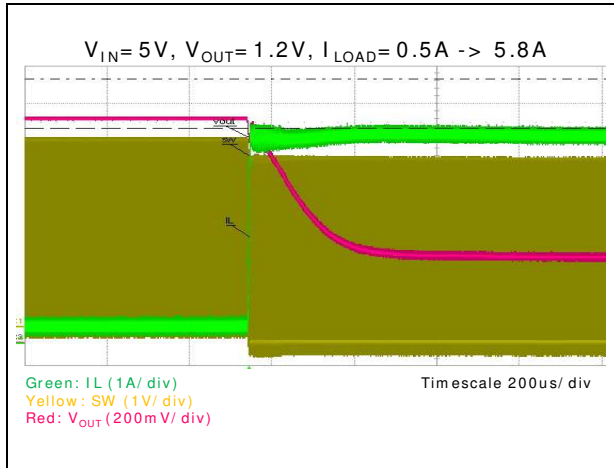
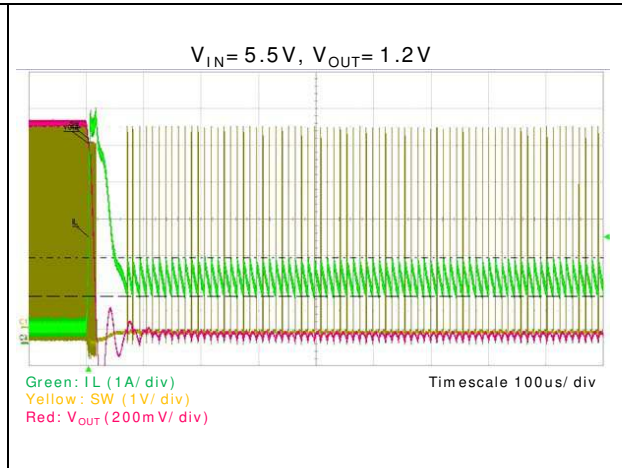

Figure 17. Short-circuit protection



8 Package mechanical data

In order to meet environmental requirements, ST offers these devices in different grades of ECOPACK® packages, depending on their level of environmental compliance. ECOPACK specifications, grade definitions and product status are available at: www.st.com. ECOPACK is an ST trademark.

Table 10. VFQFPN8 (4x4x1.0 mm) mechanical data

Dim.	mm			inch		
	Min.	Typ.	Max.	Min.	Typ.	Max.
A	0.80	0.90	1.00	0.0315	0.0354	0.0394
A1		0.02	0.05		0.0008	0.0020
A3		0.20			0.0079	
b	0.23	0.30	0.38	0.009	0.0117	0.0149
D	3.90	4.00	4.10	0.153	0.157	0.161
D2	2.82	3.00	3.23	0.111	0.118	0.127
E	3.90	4.00	4.10	0.153	0.157	0.161
E2	2.05	2.20	2.30	0.081	0.087	0.091
e		0.80			0.031	
L	0.40	0.50	0.60	0.016	0.020	0.024

Figure 18. Package dimensions

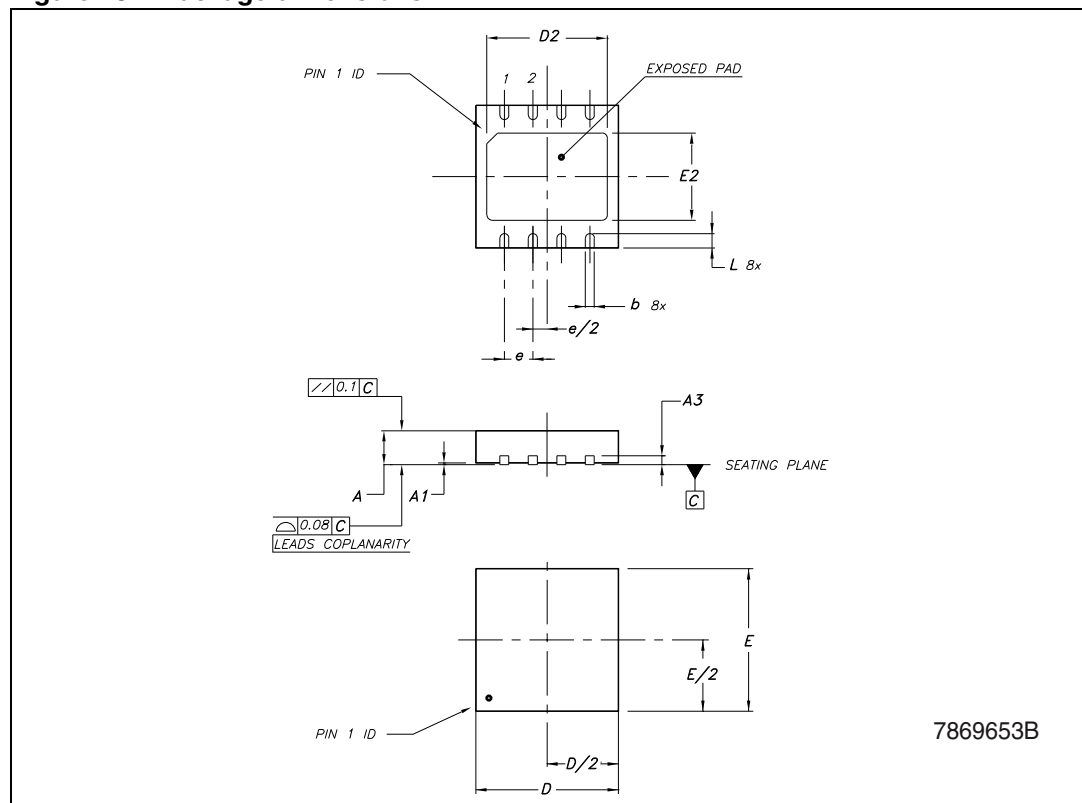
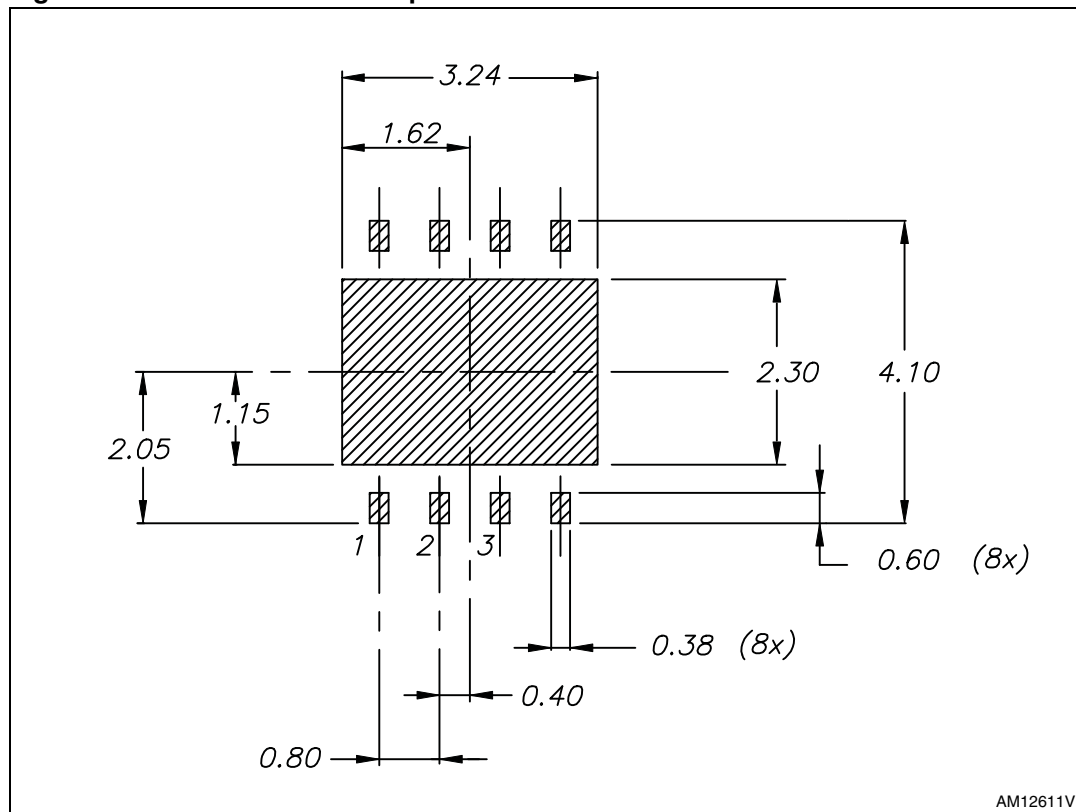

Figure 19. Recommended footprint^(a)



AM12611V1

9 Order codes

Table 11. Ordering information

Order codes	Package
ST1S32PUR	VDFFPN 4x4 8L

10 Revision history

Table 12. Document revision history

Date	Revision	Changes
31-May-2012	1	First release.

a. Dimensions are in mm.

Please Read Carefully:

Information in this document is provided solely in connection with ST products. STMicroelectronics NV and its subsidiaries ("ST") reserve the right to make changes, corrections, modifications or improvements, to this document, and the products and services described herein at any time, without notice.

All ST products are sold pursuant to ST's terms and conditions of sale.

Purchasers are solely responsible for the choice, selection and use of the ST products and services described herein, and ST assumes no liability whatsoever relating to the choice, selection or use of the ST products and services described herein.

No license, express or implied, by estoppel or otherwise, to any intellectual property rights is granted under this document. If any part of this document refers to any third party products or services it shall not be deemed a license grant by ST for the use of such third party products or services, or any intellectual property contained therein or considered as a warranty covering the use in any manner whatsoever of such third party products or services or any intellectual property contained therein.

UNLESS OTHERWISE SET FORTH IN ST'S TERMS AND CONDITIONS OF SALE ST DISCLAIMS ANY EXPRESS OR IMPLIED WARRANTY WITH RESPECT TO THE USE AND/OR SALE OF ST PRODUCTS INCLUDING WITHOUT LIMITATION IMPLIED WARRANTIES OF MERCHANTABILITY, FITNESS FOR A PARTICULAR PURPOSE (AND THEIR EQUIVALENTS UNDER THE LAWS OF ANY JURISDICTION), OR INFRINGEMENT OF ANY PATENT, COPYRIGHT OR OTHER INTELLECTUAL PROPERTY RIGHT.

UNLESS EXPRESSLY APPROVED IN WRITING BY TWO AUTHORIZED ST REPRESENTATIVES, ST PRODUCTS ARE NOT RECOMMENDED, AUTHORIZED OR WARRANTED FOR USE IN MILITARY, AIR CRAFT, SPACE, LIFE SAVING, OR LIFE SUSTAINING APPLICATIONS, NOR IN PRODUCTS OR SYSTEMS WHERE FAILURE OR MALFUNCTION MAY RESULT IN PERSONAL INJURY, DEATH, OR SEVERE PROPERTY OR ENVIRONMENTAL DAMAGE. ST PRODUCTS WHICH ARE NOT SPECIFIED AS "AUTOMOTIVE GRADE" MAY ONLY BE USED IN AUTOMOTIVE APPLICATIONS AT USER'S OWN RISK.

Resale of ST products with provisions different from the statements and/or technical features set forth in this document shall immediately void any warranty granted by ST for the ST product or service described herein and shall not create or extend in any manner whatsoever, any liability of ST.

ST and the ST logo are trademarks or registered trademarks of ST in various countries.

Information in this document supersedes and replaces all information previously supplied.

The ST logo is a registered trademark of STMicroelectronics. All other names are the property of their respective owners.

© 2012 STMicroelectronics - All rights reserved

STMicroelectronics group of companies

Australia - Belgium - Brazil - Canada - China - Czech Republic - Finland - France - Germany - Hong Kong - India - Israel - Italy - Japan - Malaysia - Malta - Morocco - Philippines - Singapore - Spain - Sweden - Switzerland - United Kingdom - United States of America

www.st.com

