

2000 CONSOLE- SERIES

ASSEMBLY INSTRUCTIONS FOR BASE SWING FREAME ASSEMBLY

BUL10061
REV. A
PAGE 1 OF 2

PART NO.	A	B
2CSFB19	22.05	19.275
2CSFB24	22.05	24.275

Corner brkt hinge side top & bot. (2)
mount using 1/4-20 screw and kep nut

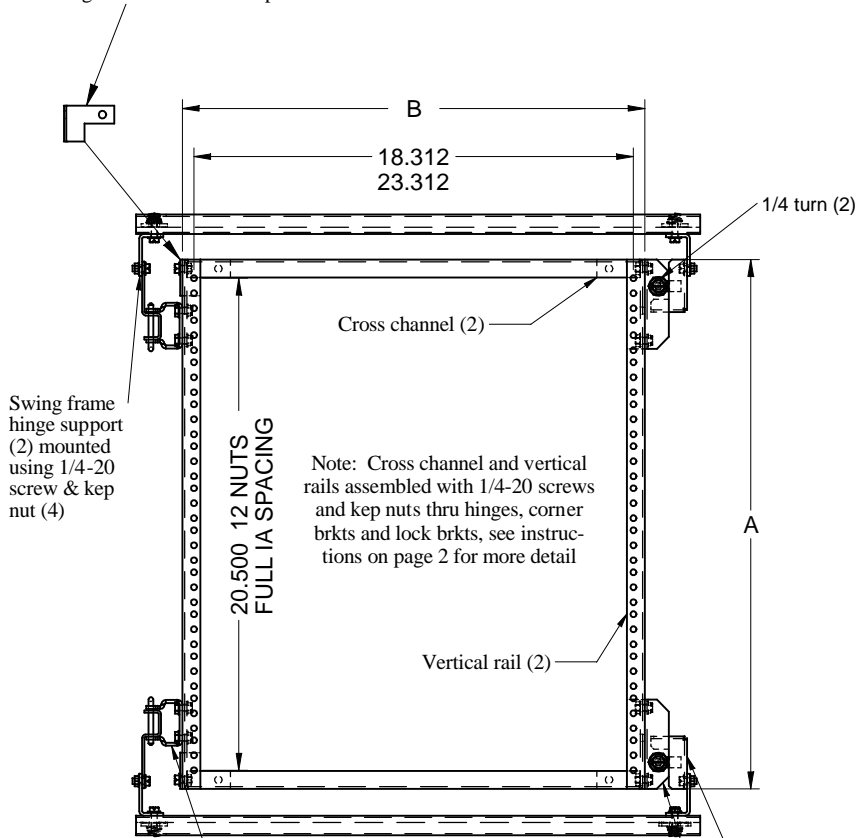

Front view

Hinge mounted to frame(2)
using 1/4-20 screw & kep
nut (4) see page 2 for detail

Stop brkt (2)
mount using 1/4-20
screw and kep nut (4) see
page 2 for more detail

Locking brkt (2)
mount using 1/4-20
screw and kep nut (4) see
page 2 for more detail

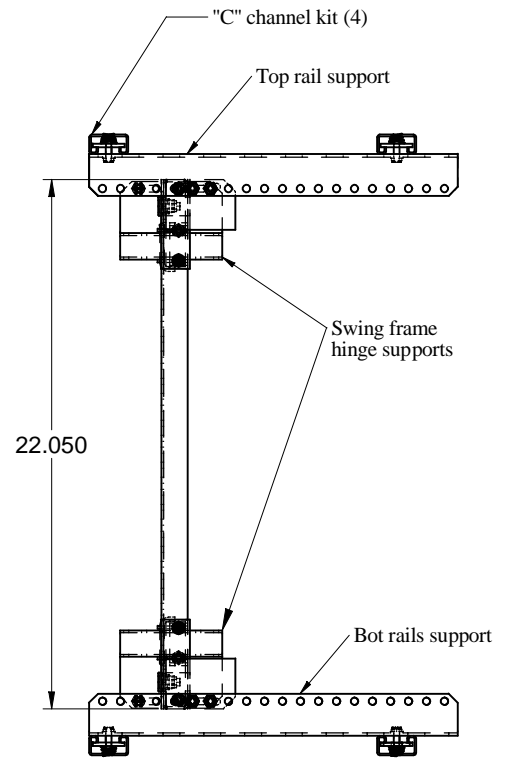

Side view

TOOL BOX



3/8, 7/16" Socket
Wrench



3/8, 7/16" Open
End Wrench



1/4 Slot Head
Screw Driver



**HAMMOND
MANUFACTURING™**
ELECTRONICS GROUP

visit our website @ www.hammondmfg.com

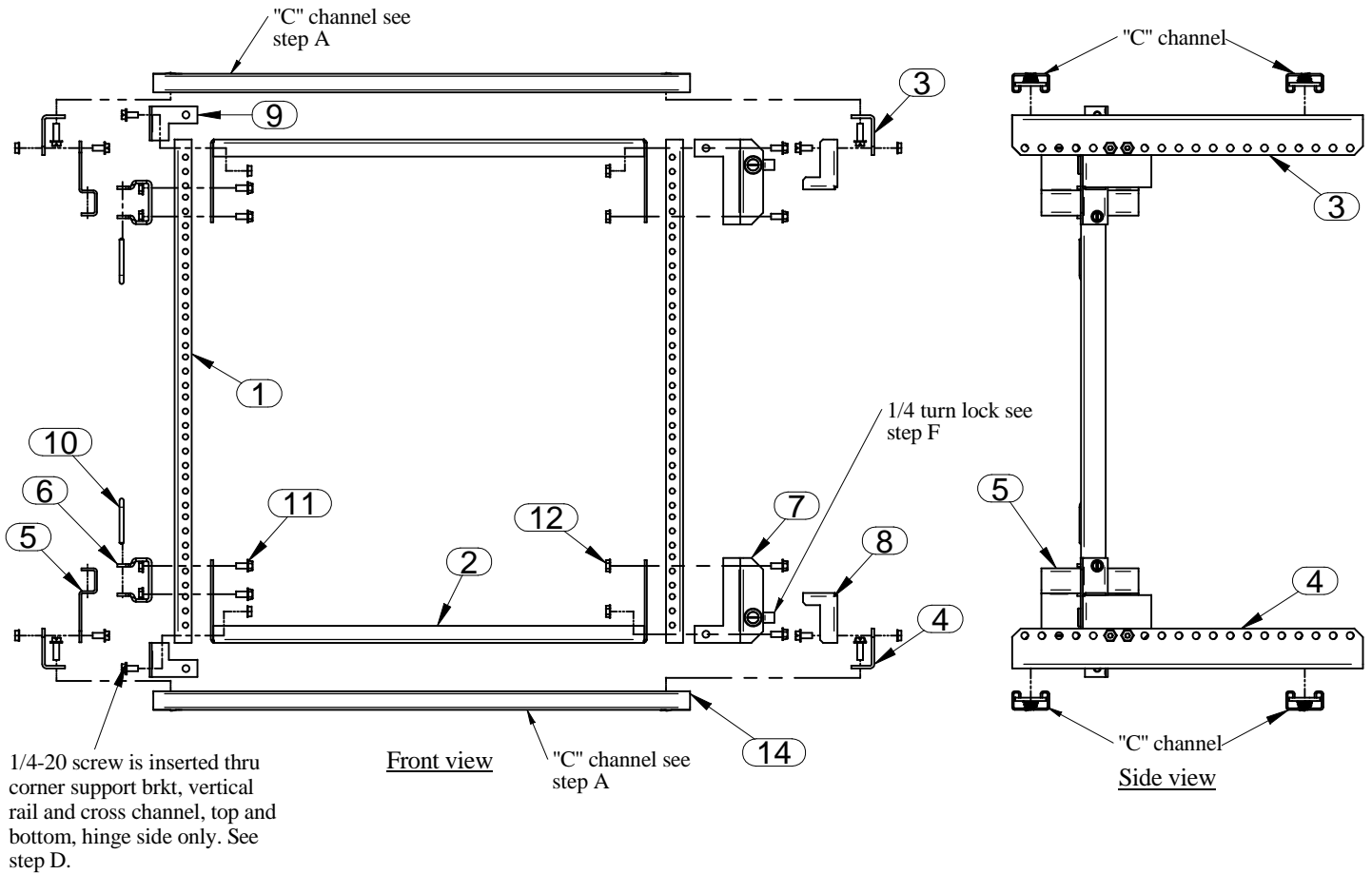

PARTS LIST		
ITEM No.	DESCRIPTION	QTY
1	VERTICAL RAIL	2
2	CROSS CHANNEL	2
3	SUPPORT BRACKET TOP (NOT INC)	2
4	SUPPORT BRACKET BOTTOM	2
5	HINGE BRACKET	2
6	HINGE BRACKET	2
7	LOCKING BRACKET	2
8	STOP BRACKET	2
9	CORNER SUPPORT BRACKET	2
10	HINGE PIN	2
11	1/4-20 SCREW	16
12	1/4-20 KEP NUT	16
13	SPRING STEEL CATCH	2
14	1/4-20 SPRING NUTS (NOT INC)	8

ASSEMBLY INSTRUCTIONS:

- Mount C channel mounting kit as per instructions in 2CMC kit purchased separately
- Mount top and bottom support brkts (items 3 & 4) as shown above and also as shown in 2CBRSK kits purchased separately
- Mount hinge brkts (item 5) and stop brkts (item 8) onto rail supports top and bottom. Assemble using 1/4-20 screws and nuts (items 11 & 12). Note that frames can be mounted hinged left or right hand. Left hand hinge assembly shown.
- Assemble swing frame parts: EIA spaced vertical rails (item 1) to cross channels (item 2), using locking brkts (item 7), hinge (item 6), and corner brkts (item 9). Secure using 1/4-20 hardware supplied.
- Mount swing frame onto hinge bracket using hinge pins (item 10) top and bottom. Secure hinge pin using spring catch (item 14).
- Close frame against the stop bracket on lock side and turn 1/4 turn lock to lock frame into place.

TOOL BOX



3/8, 7/16" Socket Wrench



3/8, 7/16" Open End Wrench



1/4 Slot Head Screw Driver

