



Features

- High energy handling density
- Hybrid (MOV and GDT) design
- Extended temperature range
- Ring-wave tolerant
- Low capacitance
- UL recognized 
- RoHS compliant*

IsoMOV™



IsoMOV™ Series - Hybrid Protection Component

General Information

Bourns introduces its hybrid technology that combines the breakthrough surge performance of EdgMOV™ protection devices with an integrated Gas Discharge Tube (GDT) isolation structure to create the innovative IsoMOV™ Series Hybrid Protection Component. By combining the best features of both MOV and GDT technologies into a single component, the IsoMOV™ Series achieves high performance as a long life protector with lower capacitance, very low leakage and superb energy handling density. The IsoMOV™ Series is ideally suited for AC and DC power applications where premium performance and/or space savings are required.

Additional Information

Click these links for more information:



PRODUCT
SELECTOR



TECHNICAL
LIBRARY



INVENTORY



SAMPLES



CONTACT

Agency Recognition

Agency	Standard	File Number
	1449 - 4th Ed. Type 4 CA Canadian Type 5 SPD CSA C22.2 No. 269.4-17	E313168

Electrical Characteristics ⁽¹⁾ (@ T_A = 25 °C Unless Otherwise Noted)

Bourns Part No.	Operating				Protection						
	Max. Continuous Operating Voltage (MCOV)		Maximum Leakage @ MCOV ⁽²⁾	Nominal Capacitance	I _{nom} ^{(3) (4)}		I _{max} ⁽⁴⁾	Energy ⁽⁵⁾	Ring Wave Surge IEEE 62.41	Maximum Clamping Voltage	
	V _{rms}	V _{dc}	A _{dc}	20 kHz	15 Operations	10 Operations	1 Operation	1 Operation	200 A	V _c	I _c
	V	V	μA	pF	A		A	J	Operations	V	A
IsoM3-175	175	225	< 10	30	3,000		6,000	88	± 250	470	50
IsoM3-230	230	300	< 10	30	3,000		6,000	109	± 250	620	50
IsoM3-250	250	320	< 10	30	3,000		6,000	117	± 250	675	50
IsoM3-275	275	350	< 10	30	3,000		6,000	126	± 250	730	50
IsoM3-300	300	385	< 10	30	3,000		6,000	136	± 250	800	50
IsoM3-320	320	415	< 10	30	3,000		6,000	144	± 250	875	50
IsoM5-175	175	225	< 10	40	5,000		10,000	144	± 250	470	100
IsoM5-230	230	300	< 10	40	5,000		10,000	188	± 250	620	100
IsoM5-250	250	320	< 10	40	5,000		10,000	203	± 250	675	100
IsoM5-275	275	350	< 10	40	5,000		10,000	223	± 250	730	100
IsoM5-300	300	385	< 10	40	5,000		10,000	242	± 250	800	100
IsoM5-320	320	415	< 10	40	5,000		10,000	258	± 250	875	100
IsoM5-380	385	505	< 10	40	5,000		10,000	305	± 250	1000	100
IsoM5-420	420	560	< 10	40	5,000		10,000	336	± 250	1100	100
IsoM5-510	510	670	< 10	40	5,000		10,000	407	± 250	1300	100
IsoM5-555	555	745	< 10	40	5,000		10,000	442	± 250	1400	100
IsoM8-250	250	320	< 10	50		8,000	15,000	313	± 250	675	200
IsoM8-275	275	350	< 10	50		8,000	15,000	340	± 250	730	200
IsoM8-300	300	385	< 10	50		8,000	15,000	367	± 250	800	200
IsoM8-320	320	415	< 10	50		8,000	15,000	388	± 250	875	200
IsoM8-380	385	505	< 10	50		8,000	15,000	453	± 250	1000	200
IsoM8-420	420	560	< 10	50		8,000	15,000	497	± 250	1100	200
IsoM8-510	510	670	< 10	50		8,000	15,000	594	± 250	1300	200
IsoM8-555	555	745	< 10	50		8,000	15,000	643	± 250	1400	200

(1) At delivery AQL 0.65 Level II, DIN ISO 2859.

(2) Maximum leakage limits after life ratings may exceed 10 μA, but will continue to protect at MCOV.

(3) I_{nom} service life specified at 3-minute time intervals between surges with rated MCOV applied during the entire resting period and 15 minutes after the last surge.

(4) Surge profile 8/20 μs per IEC 61000-4-5.

(5) Measured at I_{max}, 8/20 μs using numerical integration method $E = \int_0^T P(t)dt$



WARNING Cancer and Reproductive Harm
www.P65Warnings.ca.gov

*"IsoMOV" and "EdgMOV" are trademarks of Bourns, Inc.
*RoHS Directive 2015/863, Mar 31, 2015 and Annex.

Specifications are subject to change without notice. Users should verify actual device performance in their specific applications. The products described herein and this document are subject to specific legal disclaimers as set forth on the last page of this document, and at www.bourns.com/docs/legal/disclaimer.pdf.

Applications

AC Line Protection

- White goods
- Fire alarm systems
- High value consumer goods
- LED lighting
- UL1449 SPD
- Industrial equipment

DC Line Protection

- Solar inverters
- Power supplies
- Distribution systems

IsoMOV™ Series - Hybrid Protection Component BOURNS®

Environmental Specifications

Storage Temperature Range (T_{STG}) -40 °C to +125 °C
 Operating Temperature Range (T_{OPR})..... -40 °C to +125 °C
 Climatic Category (IEC 60068-1)..... 40 / 125 / 21
 Moisture Sensitivity Level 1
 ESD Classification (HBM)..... N/A

How to Order

IsoM 8 - 320 - B - L2

Model Designator _____
 IsoM = IsoMOV™ Hybrid Protection Component

Component I_{nom} Rating _____
 3 = 3 kA
 5 = 5 kA
 8 = 8 kA

RMS Voltage _____
 See Electrical Characteristics Table

Packaging _____
 B = Bulk (Standard)
 R = Reel Pack*

Lead Style** _____
 L2 = In-Line Leads (Standard)

*Reel Pack option not available for IsoM8 models.
 **L1 and L5 lead styles available upon request.

Circuit Diagram

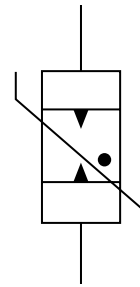

Typical Part Marking

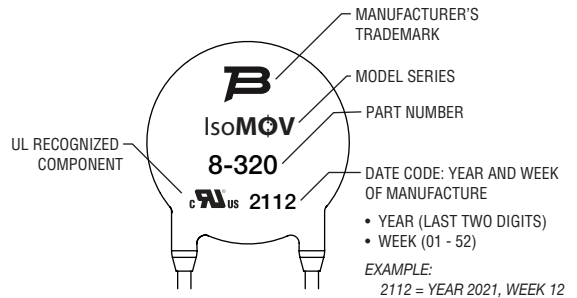

Product Dimensions

IsoM3-xxx-L2 In-Line Leads

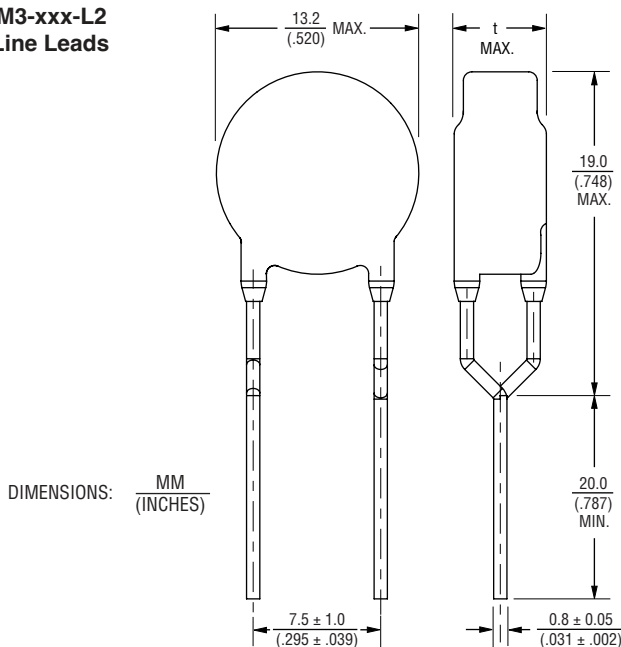

Model	IsoM3-xxx-L2
	t MAX.
IsoM3-175	$\frac{6.1}{(.240)}$
IsoM3-230	$\frac{6.5}{(.256)}$
IsoM3-250	$\frac{6.7}{(.264)}$
IsoM3-275	$\frac{6.9}{(.272)}$
IsoM3-300	$\frac{7.1}{(.280)}$
IsoM3-320	$\frac{7.2}{(.283)}$

IsoMOV™ Series - Hybrid Protection Component

BOURNS®

Product Dimensions (Continued)

IsoM5-xxx-L2 In-Line Leads

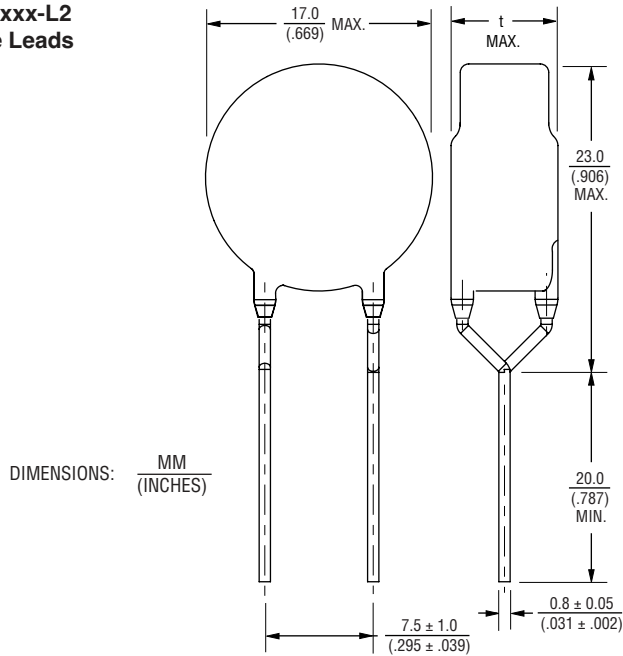

Model	IsoM5-xxx-L2
	t MAX.
IsoM5-175	$\frac{6.0}{(.236)}$
IsoM5-230	$\frac{6.5}{(.256)}$
IsoM5-250	$\frac{6.7}{(.264)}$
IsoM5-275	$\frac{6.8}{(.268)}$
IsoM5-300	$\frac{7.1}{(.280)}$
IsoM5-320	$\frac{7.1}{(.280)}$
IsoM5-380	$\frac{7.7}{(.303)}$
IsoM5-420	$\frac{8.1}{(.319)}$
IsoM5-510	$\frac{8.8}{(.346)}$
IsoM5-555	$\frac{9.0}{(.354)}$

IsoM8-xxx-L2 In-Line Leads

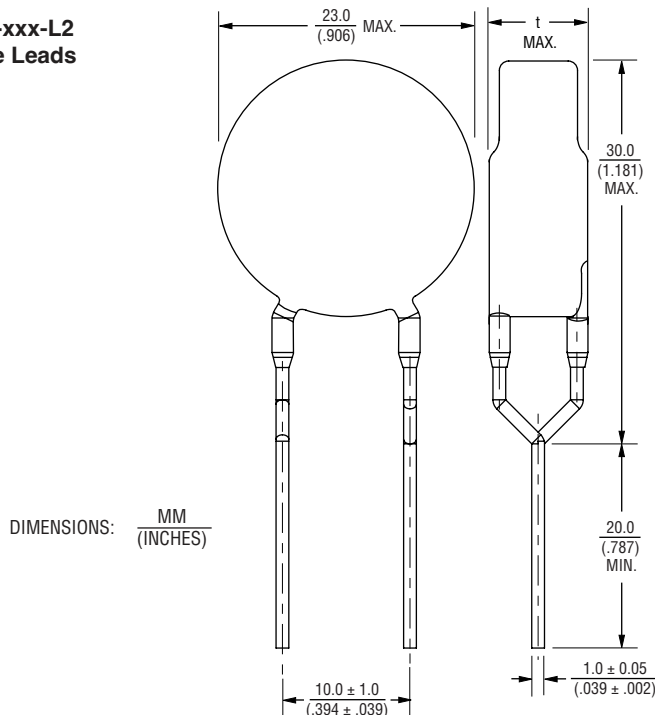

Model	IsoM8-xxx-L2
	t MAX.
IsoM8-250	$\frac{7.1}{(.280)}$
IsoM8-275	$\frac{7.2}{(.283)}$
IsoM8-300	$\frac{7.5}{(.295)}$
IsoM8-320	$\frac{7.6}{(.299)}$
IsoM8-380	$\frac{8.0}{(.315)}$
IsoM8-420	$\frac{8.4}{(.331)}$
IsoM8-510	$\frac{9.2}{(.362)}$
IsoM8-555	$\frac{9.4}{(.370)}$

Specifications are subject to change without notice.

Users should verify actual device performance in their specific applications.

The products described herein and this document are subject to specific legal disclaimers as set forth on the last page of this document, and at www.bourns.com/docs/legal/disclaimer.pdf.

IsoMOV™ Series - Hybrid Protection Component BOURNS®

Packaging Specifications

TAPE

Conforms to IEC 60286-2:2015.

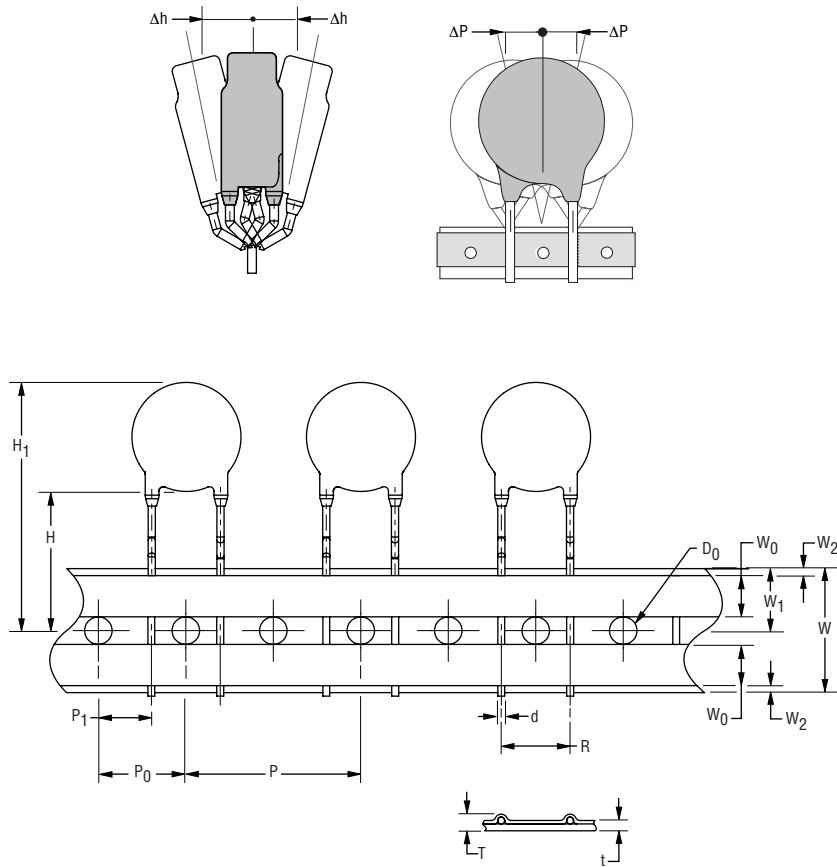

Symbol	Parameter	Dimension
W	Carrier tape width	$\frac{18 + 1.0/-0.5}{(.709 + .039/-0.020)}$
W ₀	Hold down tape width	$\frac{5}{(.197)}$ MIN.
W ₁	Sprocket hole position	$\frac{9 + 0.75/-0.5}{(.354 + .030/-0.020)}$
W ₂	Distance between the upper edges of the carrier tape and hold down tape	$\frac{3}{(.118)}$ MAX.
T	Total tape thickness	$\frac{1.7}{(.067)}$ MAX.
t	Tape thickness	$\frac{0.9}{(.035)}$ MAX.
P	Pitch of component	$\frac{25.4 \pm 1.0}{(1.000 \pm .039)}$
P ₀	Feed hole pitch	$\frac{12.7 \pm 0.3}{(.500 \pm .012)}$
P ₁	Feed hole center to pitch	$\frac{8.95 \pm 0.7}{(.352 \pm .028)}$
R	Lead spacing	$\frac{7.5 \pm 1.0}{(.295 + .039)}$
ΔP	Component alignment	$\frac{\pm 1.3}{(\pm .051)}$ MAX.
Δh	Component alignment	$\frac{\pm 2.0}{(\pm .079)}$ MAX.
d	Wire diameter	$\frac{0.8 \pm 0.05}{(.031 \pm .002)}$
D ₀	Feed hole diameter	$\frac{4 \pm 0.2}{(.157 \pm .008)}$
H	Height from tape center to component base	$\frac{18 + 2.0/-0.0}{(.709 + .079/-0.000)}$
H ₁	Component height	$\frac{46.5}{(1.831)}$ MAX.

DIMENSIONS: $\frac{\text{MM}}{\text{(INCHES)}}$

REEL

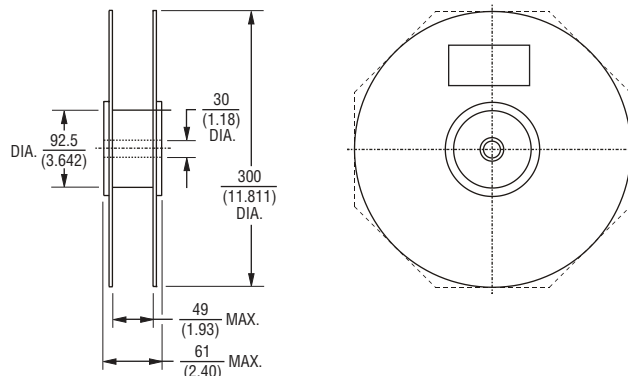

DIMENSIONS: $\frac{\text{MM}}{\text{(INCHES)}}$

Specifications are subject to change without notice.

Users should verify actual device performance in their specific applications.

The products described herein and this document are subject to specific legal disclaimers as set forth on the last page of this document, and at www.bourns.com/docs/legal/disclaimer.pdf.

IsoMOV™ Series - Hybrid Protection Component

BOURNS®

Packaging Quantities - Bulk

Voltage	Model		
	IsoM3	IsoM5	IsoM8
175	500	300	200
230			
250			
275			
300			
320			
380			
420			
510			
555			

Packaging Quantities - Reel

Voltage	Model		
	IsoM3	IsoM5	IsoM8
175	500	400	
230			
250			
275	400		
300			
320			
380		300	
420			
510			
555			

Assembly Recommendations for Through-Hole Components

Lead-free Wave Soldering Profile - Pb-free wave profile requirements for soldering heat resistance of components

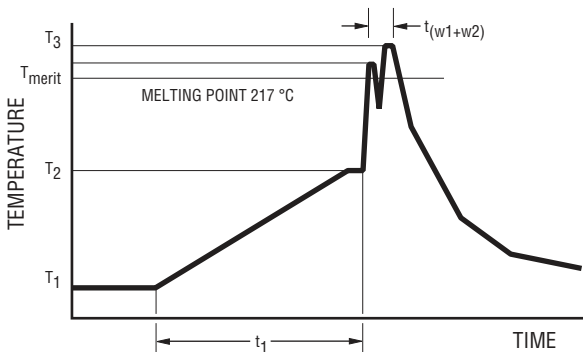

Parameter	Symbol	Specification
Preheating temperature gradient		4 °C/sec. max.
Preheating time	t ₁	2 to 5 min.
Min. preheating temperature	T ₁	130 °C
Max. preheating temperature	T ₂	180 °C
Melting temperature/point	T _{meltv}	217 °C
Time in wave soldering phase (w ₁ +w ₂)	t _{w1+w2}	10 sec.
Max. wave temperature (w ₁ +w ₂)	T _s	265 °C +0/-5 °C
Cooling temperature gradient		6° C/sec. max.
Temperature jump from T ₂ to T ₃ (w ₁)	T _{3(w1)} - T ₂	120 °C max
Time from 25 °C to T ₃ (wave temperature)		8 min. max.

BOURNS®

Asia-Pacific: Tel: +886-2 2562-4117 • Email: asiacus@bourns.com

EMEA: Tel: +36 88 885 877 • Email: eurocus@bourns.com

The Americas: Tel: +1-951 781-5500 • Email: americus@bourns.com

www.bourns.com

REV. E 10/22

Specifications are subject to change without notice.

Users should verify actual device performance in their specific applications.

The products described herein and this document are subject to specific legal disclaimers as set forth on the last page of this document, and at www.bourns.com/docs/legal/disclaimer.pdf.

This legal disclaimer applies to purchasers and users of Bourns® products manufactured by or on behalf of Bourns, Inc. and its affiliates (collectively, "Bourns").

Unless otherwise expressly indicated in writing, Bourns® products and data sheets relating thereto are subject to change without notice. Users should check for and obtain the latest relevant information and verify that such information is current and complete before placing orders for Bourns® products.

The characteristics and parameters of a Bourns® product set forth in its data sheet are based on laboratory conditions, and statements regarding the suitability of products for certain types of applications are based on Bourns' knowledge of typical requirements in generic applications. The characteristics and parameters of a Bourns® product in a user application may vary from the data sheet characteristics and parameters due to (i) the combination of the Bourns® product with other components in the user's application, or (ii) the environment of the user application itself. The characteristics and parameters of a Bourns® product also can and do vary in different applications and actual performance may vary over time. Users should always verify the actual performance of the Bourns® product in their specific devices and applications, and make their own independent judgments regarding the amount of additional test margin to design into their device or application to compensate for differences between laboratory and real world conditions.

Unless Bourns has explicitly designated an individual Bourns® product as meeting the requirements of a particular industry standard (e.g., ISO/TS 16949) or a particular qualification (e.g., UL listed or recognized), Bourns is not responsible for any failure of an individual Bourns® product to meet the requirements of such industry standard or particular qualification. Users of Bourns® products are responsible for ensuring compliance with safety-related requirements and standards applicable to their devices or applications.

Bourns® products are not recommended, authorized or intended for use in nuclear, lifesaving, life-critical or life-sustaining applications, nor in any other applications where failure or malfunction may result in personal injury, death, or severe property or environmental damage. Unless expressly and specifically approved in writing by two authorized Bourns representatives on a case-by-case basis, use of any Bourns® products in such unauthorized applications might not be safe and thus is at the user's sole risk. Life-critical applications include devices identified by the U.S. Food and Drug Administration as Class III devices and generally equivalent classifications outside of the United States.

Bourns expressly identifies those Bourns® standard products that are suitable for use in automotive applications on such products' data sheets in the section entitled "Applications." Unless expressly and specifically approved in writing by two authorized Bourns representatives on a case-by-case basis, use of any other Bourns® standard products in an automotive application might not be safe and thus is not recommended, authorized or intended and is at the user's sole risk. If Bourns expressly identifies a sub-category of automotive application in the data sheet for its standard products (such as infotainment or lighting), such identification means that Bourns has reviewed its standard product and has determined that if such Bourns® standard product is considered for potential use in automotive applications, it should only be used in such sub-category of automotive applications. Any reference to Bourns® standard product in the data sheet as compliant with the AEC-Q standard or "automotive grade" does not by itself mean that Bourns has approved such product for use in an automotive application.

Bourns® standard products are not tested to comply with United States Federal Aviation Administration standards generally or any other generally equivalent governmental organization standard applicable to products designed or manufactured for use in aircraft or space applications. Bourns expressly identifies Bourns® standard products that are suitable for use in aircraft or space applications on such products' data sheets in the section entitled "Applications." Unless expressly and specifically approved in writing by two authorized Bourns representatives on a case-by-case basis, use of any other Bourns® standard product in an aircraft or space application might not be safe and thus is not recommended, authorized or intended and is at the user's sole risk.

The use and level of testing applicable to Bourns® custom products shall be negotiated on a case-by-case basis by Bourns and the user for which such Bourns® custom products are specially designed. Absent a written agreement between Bourns and the user regarding the use and level of such testing, the above provisions applicable to Bourns® standard products shall also apply to such Bourns® custom products.

Users shall not sell, transfer, export or re-export any Bourns® products or technology for use in activities which involve the design, development, production, use or stockpiling of nuclear, chemical or biological weapons or missiles, nor shall they use Bourns® products or technology in any facility which engages in activities relating to such devices. The foregoing restrictions apply to all uses and applications that violate national or international prohibitions, including embargos or international regulations. Further, Bourns® products and Bourns technology and technical data may not under any circumstance be exported or re-exported to countries subject to international sanctions or embargoes. Bourns® products may not, without prior authorization from Bourns and/or the U.S. Government, be resold, transferred, or re-exported to any party not eligible to receive U.S. commodities, software, and technical data.

To the maximum extent permitted by applicable law, Bourns disclaims (i) any and all liability for special, punitive, consequential, incidental or indirect damages or lost revenues or lost profits, and (ii) any and all implied warranties, including implied warranties of fitness for particular purpose, non-infringement and merchantability.

For your convenience, copies of this Legal Disclaimer Notice with German, Spanish, Japanese, Traditional Chinese and Simplified Chinese bilingual versions are available at:

Web Page: <http://www.bourns.com/legal/disclaimers-terms-and-policies>

PDF: <http://www.bourns.com/docs/Legal/disclaimer.pdf>