

REV.	DATE	ECR NO.	DESCRIPTION
NC	07/19/12	XXXXXX	INITIAL RELEASE

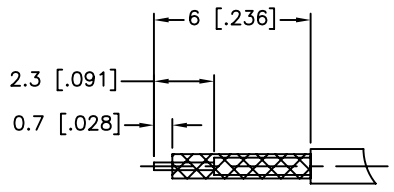

RECOMMENDED  
CABLE STRIPPING DIM'S

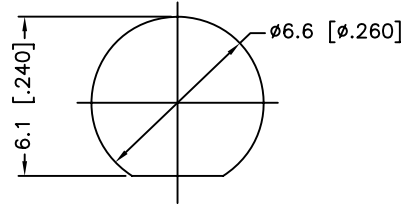

RECOMMENDED  
MOUNTING HOLE

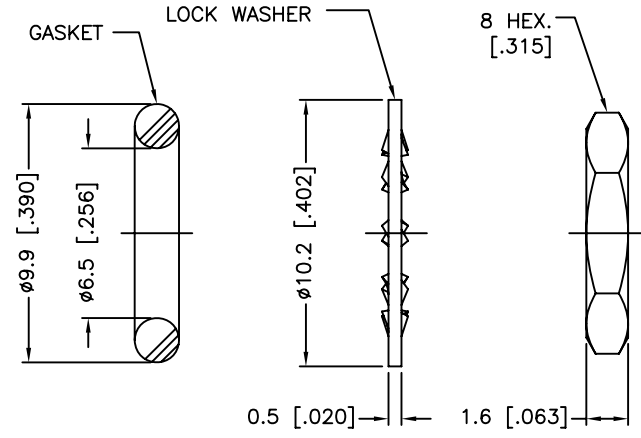
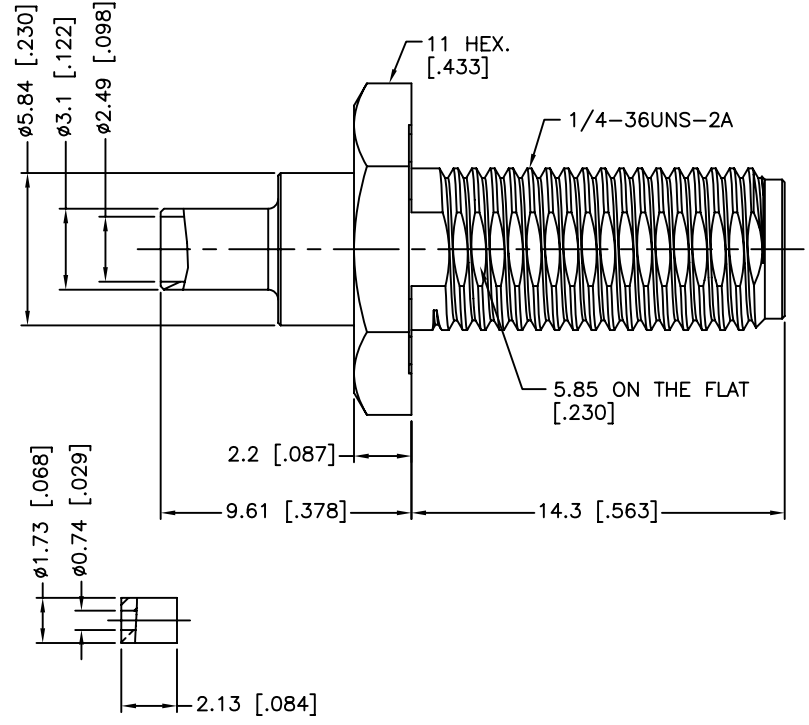
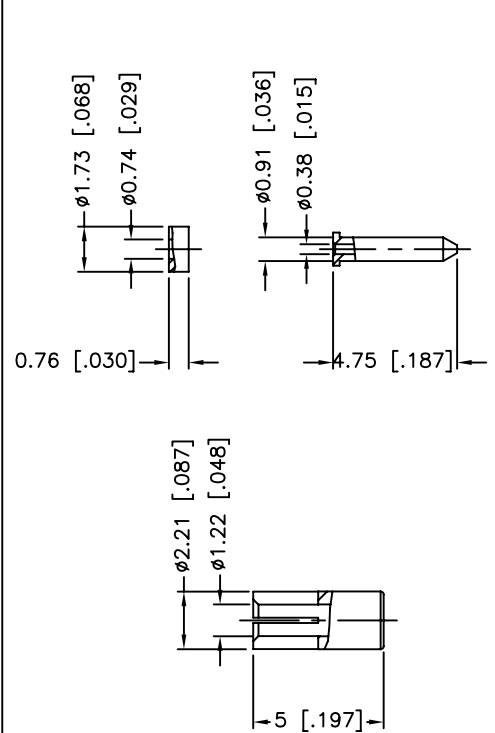
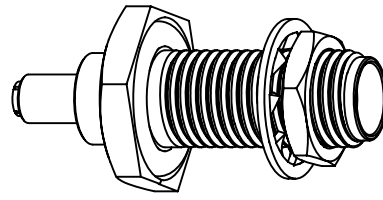

1. IMPEDANCE: 50 OHM
2. FREQUENCY RANGE: DC 0-6 GHz
3. VSWR(RETURN LOSS): 1.28(18.22 dB), MAX.
4. DIELECTRIC WITHSTANDING VOLTAGE: 250 VRMS, MIN.
5. DURABILITY: 500 CYCLES MIN.
6. TEMPERATURE RANGE: -65°C TO +165°C
7. THE ASSEMBLIES MUST TEST BY SUBMERGING IN WATER FOR 1 MINUTE AT 8 PSI WITH NO VISIBLE LEAKAGE(COMPLIANT WITH IP67).
8. CRIMPED FERRULE  
HEX CRIMP SIZE .100"
9. CONTACT PIN TO SOLDER
10. MAX. PANEL THICKNESS=5.95mm

11	HEX NUT	BRASS	GOLD	1
10	LOCK WASHER	BRASS	GOLD	1
9	GASKET	SILICON RUBBER	RED	1
8	INNER FERRULE	BRASS	GOLD	1
7	SLEEVE	BRASS	GOLD	1
6	INSULATOR	PTFE	NATURAL	1
5	CONTACT PIN	BRASS	GOLD	1
4	CONTACT PIN	BER. COPPER	GOLD	1
3	INSULATOR	PTFE	NATURAL	1
2	O-RING	SILICON RUBBER	RED	1
1	BODY	BRASS	GOLD	1
	DESCRIPTION	MATERIAL	FINISH	QTY

UNLESS OTHERWISE SPECIFIED DIMENSIONS ARE IN MILLIMETERS. DIMENSIONS IN [ ] ARE IN INCHES AND FOR CUSTOMER REFERENCE ONLY.

UNLESS OTHERWISE SPECIFIED TOLERANCES FOR MILLIMETERS ARE:  
0.5 - 8mm ± 0.20mm  
8 - 30mm ± 0.40mm  
30 - 120mm ± 0.50mm

UNLESS OTHERWISE SPECIFIED TOLERANCES FOR INCHES ARE:  
.020 - .315 ± ± 0.007"  
.315 - 1.180 ± ± 0.015"  
1.180 - 4.724 ± ± 0.020"

DO NOT SCALE DRAWING

APPROVALS	DATE
DRAWN M.ZHANG	07/19/12
CHECKED	
ISSUED	
SHEET 1 OF 1	
CAD FILE C:/CONNEX/132422-10.DWG	

**Amphenol Connex**

PART DESCRIPTION  
**SMA BULKHEAD CRIMP JACK, IP-67 COMPLIANT (FOR 1.13 MM CABLE)**

PART NO. **132422-10**

DWG. NO.	132422-10.DWG	REV.	NC	SIZE	A	SCALE	NA
----------	---------------	------	----	------	---	-------	----