

SIGN	DATE	DESCRIPTION	APPROVER

THIS IS CAD DRAWING, DO NOT REVISE MANUALLY!!!

Material

- Terminal body
- (metal housing): Brass (CuZn)
- Terminal screw: Steel Zinc plating "-" slot type
- Wire guard: Stainless steel
- Surface of solder tail: Tin plated
- Insulator (housing): Thermoplastic (UL94V-0)

Electrical

- Voltage rating: 300VAC
- Current rating: 15A
- Wire range:
 - Solid wire(AWG): 14-22
 - Stranded wire(AWG): 14-22
- Torque(Lb-In): 3.5
- Screw: M3
- Wire strip length: 6-7mm
- Withstanding Voltage: 1.6KV
- Operating temperature: -30°C to +105°C
- Soldering temperature: 250°C±10°C/5 Sec
- Safety approval: 

RoHS Compliant

PART NUMBER:

OSTTQXX0100

No. of Poles	COLOR
02 2 Poles	0: Black (Standard)
03 3 Poles	5: Green
...	6: Blue
24 24 Poles	8: Grey

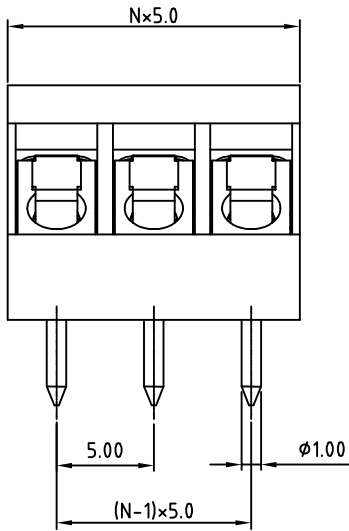
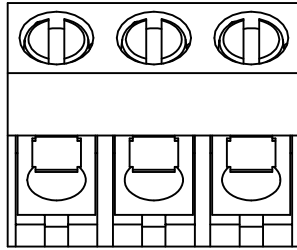

N=Number of poles

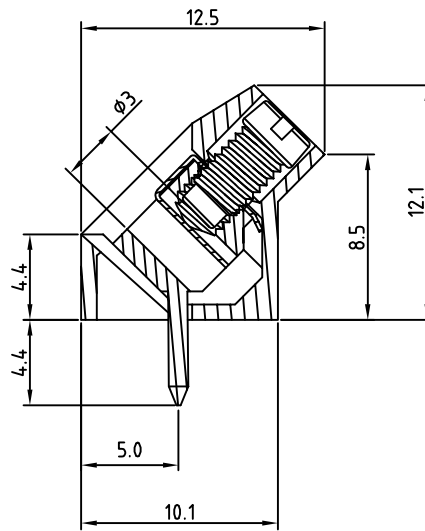

P.C.B LAYOUT

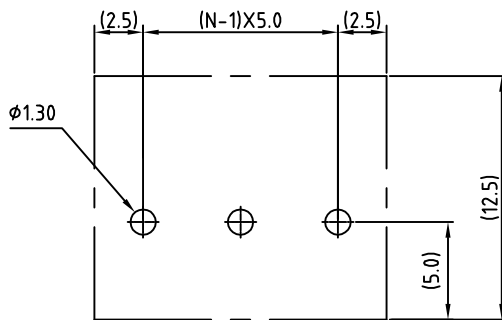

THESE DRAWINGS AND SPECIFICATIONS ARE THE PROPERTY OF ON-SHORE TECHNOLOGY, INC. AND SHALL NOT BE REPRODUCED, COPIED OR USED IN ANY MANNER WITHOUT THE PRIOR WRITTEN CONSENT OF ON-SHORE TECHNOLOGY, INC.



TITLE		OSTTQ-5.0mm series solid block				
PART NO.	OSTTQXX0100			DWG NO.	OSTTQXX0100.DWG	
APPROVED	CHECKED	DESIGNED	DRAWN	CUST NO.		
Shi Jun 2006.10.19	Shi Jun 2006.10.19	xionghaitao 2006.10.19	xionghaitao 2006.10.19			
					UNIT: mm	Tolerance
					SCALE: NONE	X. ±0.50
				SHEET: 01/01	REV.: E	X.XX ±0.30
						X.XX ±0.10
						X° ±1°