

ISL3241E, ISL3243E

QFN Packaged, ±15kV ESD Protected, +2.7V to +3.6V, 250kbps, RS-232 Transmitters/Receivers with Separate Logic Supply Pin

FN6768
Rev 2.00
June 18, 2012

The Intersil ISL324xE devices are 2.7V to 3.6V powered RS-232 transmitters/receivers which meet EIA/TIA-232 and V.28/V.24 specifications, even at $V_{CC} = 3.0V$. Additionally, they provide ±15kV ESD protection (IEC61000-4-2 Air Gap and Human Body Model) on transmitter outputs and receiver inputs (RS-232 pins). Targeted applications are POS systems, and notebook and laptop computers where the low operational, and even lower standby, power consumption is critical. Efficient on-chip charge pumps, coupled with manual and automatic power-down functions, reduce the standby supply current to a 0.5µA trickle. Tiny 5mmx5mm **Quad Flat No-Lead** (QFN) packaging and the use of small, low value capacitors ensure board space savings as well. Data rates greater than 250kbps are guaranteed at worst case load conditions.

ISL324xE are 3 driver, 5 receiver devices that, coupled with the 5x5 QFN package, provide the industry's smallest, lowest power complete serial port. The 5x5 QFN requires 60% less board area than a 28 Ld TSSOP, and is nearly 20% thinner. These devices also include a noninverting always-active receiver for "wake-up" capability.

The **ISL3243E** features an *automatic powerdown* function that powers down the on-chip power supply and driver circuits. This occurs when an attached peripheral device is shut off or the RS-232 cable is removed, conserving system power automatically without changes to the hardware or operating system. It powers up again when a valid RS-232 voltage is applied to any receiver input.

The ISL324xE feature a V_L pin that adjusts the logic pin (see "Pin Descriptions" on page 2) output levels and input thresholds to values compatible with the V_{CC} powering the external logic (e.g., a UART).

Table 1 summarizes the features of the ISL324xE.

Features

- V_L Pin for Compatibility in Mixed Voltage Systems Adjusts Logic Output Levels and Input Thresholds for Compatibility with Lower Supply Voltage Logic
- Parameters Specified for 10% Tolerance Supplies and Full Industrial Temp Range
- Pb-free Small QFN (5mmx5mm) Package is 60% Smaller than a 28 Lead TSSOP
- ESD Protection for RS-232 I/O Pins to ±15kV (IEC61000)
- Meets EIA/TIA-232 and V.28/V.24 Specifications at 3V
- RS-232 Compatible with $V_{CC} = 2.7V$
- On-Chip Voltage Converters Require Only Four External 0.1µF Capacitors
- Manual and Automatic Power-down Features
- Receiver Hysteresis for Improved Noise Immunity
- Guaranteed Minimum Data Rate. 250kbps
- Low Supply Current in Power-down State 0.5µA
- Pb-Free (RoHS compliant)

Applications

- Any Space Constrained System Requiring RS-232 Ports
 - Battery Powered, Hand-Held, and Portable Equipment
 - POS Systems and Scanners
 - Laptop Computers, Notebooks
 - GPS Receivers
- Mixed Voltage Serial Ports

Related Literature

- Technical Brief [TB363](#) "Guidelines for Handling and Processing Moisture Sensitive Surface Mount Devices"
- Technical Brief [TB379](#) "Thermal Characterization of Packages for ICs"
- Technical Brief [TB389](#) "PCB Land Pattern Design and Surface Mount Guidelines for QFN Packages"

TABLE 1. SUMMARY OF FEATURES

PART NUMBER	NO. OF Tx.	NO. OF Rx.	LOGIC SUPPLY (V_L) PIN?	NO. OF MONITOR Rx. (R_{OUTB})	DATA RATE (kbps)	Rx. ENABLE FUNCTION?	Pb-FREE?	MANUAL POWER-DOWN?	AUTOMATIC POWERDOWN FUNCTION?
ISL3241E	3	5	YES	2	250	YES	YES	YES	NO
ISL3243E	3	5	YES	1	250	NO	YES	YES	YES

Ordering Information

PART NUMBER (Notes 1, 2, 3)	PART MARKING	TEMP. RANGE (°C)	PACKAGE (Pb-Free)	PKG. DWG. #
ISL3241EIRZ	ISL3241 EIRZ	-40 to +85	32 Ld 5X5 QFN	L32.5x5B
ISL3243EIRZ	ISL3243 EIRZ	-40 to +85	32 Ld 5X5 QFN	L32.5x5B

Ordering Information (Continued)

PART NUMBER (Notes 1, 2, 3)	PART MARKING	TEMP. RANGE (°C)	PACKAGE (Pb-Free)	PKG. DWG. #
--------------------------------	-----------------	---------------------	----------------------	----------------

NOTES:

1. Add “-T*” suffix for tape and reel. Please refer to [TB347](#) for details on reel specifications.
2. These Intersil Pb-free plastic packaged products employ special Pb-free material sets, molding compounds/die attach materials, and 100% matte tin plate plus anneal (e3 termination finish, which is RoHS compliant and compatible with both SnPb and Pb-free soldering operations). Intersil Pb-free products are MSL classified at Pb-free peak reflow temperatures that meet or exceed the Pb-free requirements of IPC/JEDEC J STD-020.
3. For Moisture Sensitivity Level (MSL), please see device information page for [ISL3241E, ISL3243E](#). For more information on MSL please see tech brief [TB363](#).

Pin Configurations

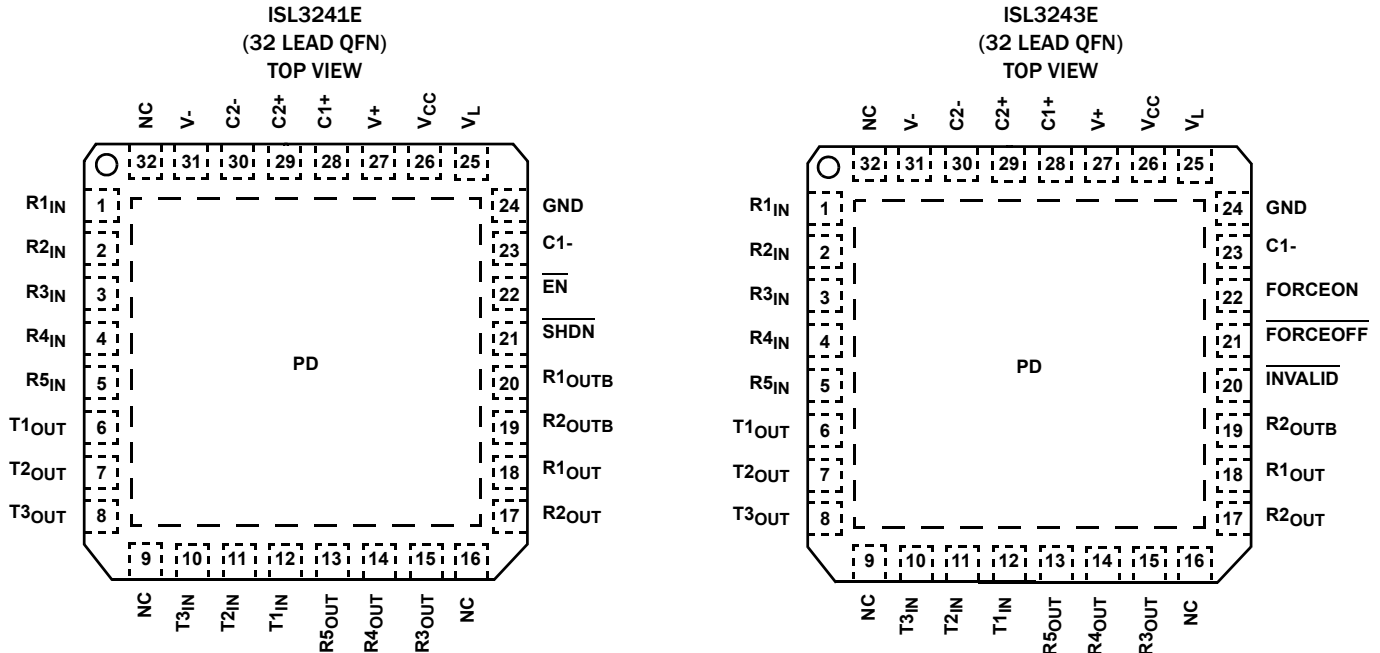

Pin Descriptions

PIN NUMBER ISL3241E	PIN NUMBER ISL3243E	PIN NAME	FUNCTION
26	26	V _{CC}	System power supply input (2.7V to 3.6V).
25	25	V _L	Logic power supply. Sets the V _{OH} of all the logic outputs and the switching point of all logic inputs. Keep V _L greater than 1.6V (1.8V - 10%) and less than or equal to V _{CC} . If V _L isn't connected to the V _{CC} supply, ensure that the V _L supply powers up after the V _{CC} supply.
27	27	V+	Internally generated positive transmitter supply (typically +5.5V).
31	31	V-	Internally generated negative transmitter supply (typically -5.5V).
24	24	GND	Ground connection. This is also the potential of the thermal pad (PD).
28	28	C1+	External capacitor (voltage doubler) is connected to this lead.
23	23	C1-	External capacitor (voltage doubler) is connected to this lead.
29	29	C2+	External capacitor (voltage inverter) is connected to this lead.
30	30	C2-	External capacitor (voltage inverter) is connected to this lead.

Pin Descriptions (Continued)

PIN NUMBER ISL3241E	PIN NUMBER ISL3243E	PIN NAME	FUNCTION
12, 11, 10	12, 11, 10	T1 _{IN} , T2 _{IN} , T3 _{IN}	TTL/CMOS compatible transmitter Inputs. The V _L voltage sets the input switching point.
6, 7, 8	6, 7, 8	T1 _{OUT} , T2 _{OUT} , T3 _{OUT}	±15kV ESD Protected, RS-232 level (nominally ±5.5V) transmitter outputs.
1, 2, 3, 4, 5	1, 2, 3, 4, 5	R1 _{IN} , R2 _{IN} , R3 _{IN} , R4 _{IN} , R5 _{IN}	±15kV ESD Protected, RS-232 compatible receiver inputs.
18, 17	18, 17	R1 _{OUT} , R2 _{OUT}	TTL/CMOS level receiver outputs. Swings between GND and V _L .
20,19	19	R1 _{OUTB} , R2 _{OUTB}	TTL/CMOS level, noninverting, always enabled receiver outputs. Swings between GND and V _L .
	20	INVALID	Active low output that indicates if no valid RS-232 levels are present on any receiver input. Swings between GND and V _L .
	21	FORCEOFF	Active low to shut down transmitters and on-chip power supply. This overrides any automatic circuitry and FORCEON (see Table 2). The V _L voltage sets the input switching point.
	22	FORCEON	Active high input to override automatic powerdown circuitry thereby keeping transmitters active. (FORCEOFF must be high). The V _L voltage sets the input switching point.
22		EN	Active low receiver enable control. The V _L voltage sets the input switching point.
21		SHDN	Active low input to shut down transmitters and on-board power supply, to place device in low power mode. The V _L voltage sets the input switching point.
9, 16, 32	9, 16, 32	NC	No Connection
		PAD	Exposed Thermal Pad. Connect to GND.

Typical Operating Circuits

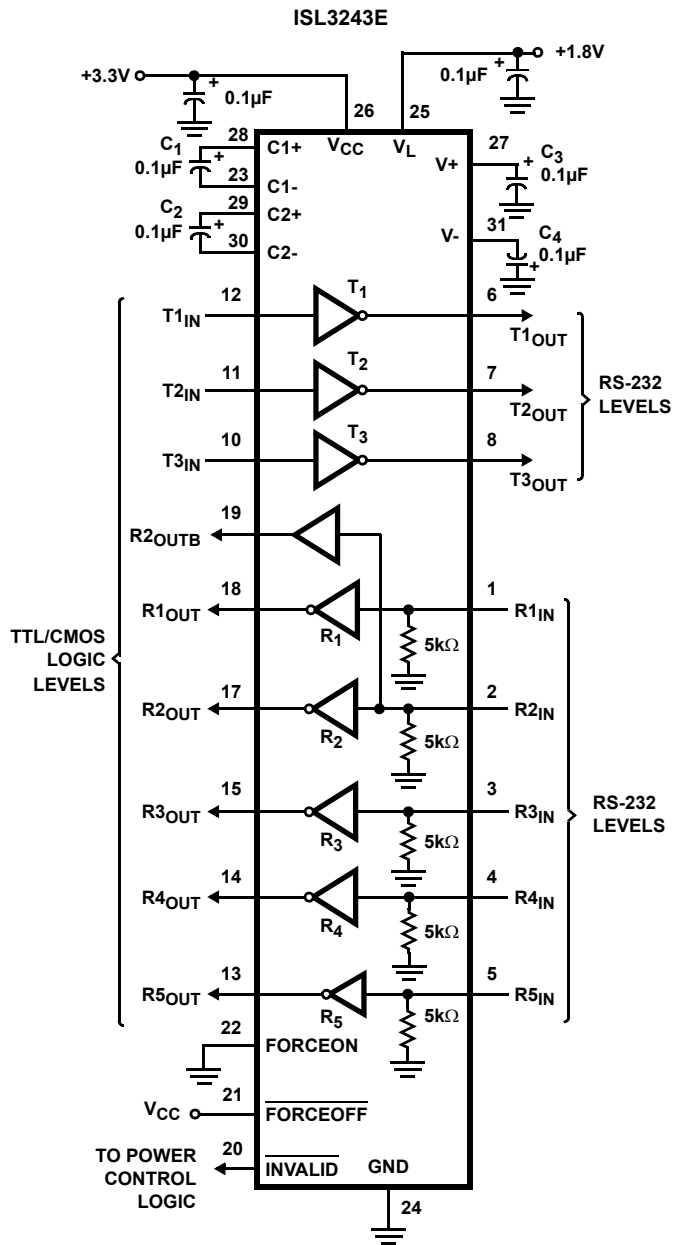
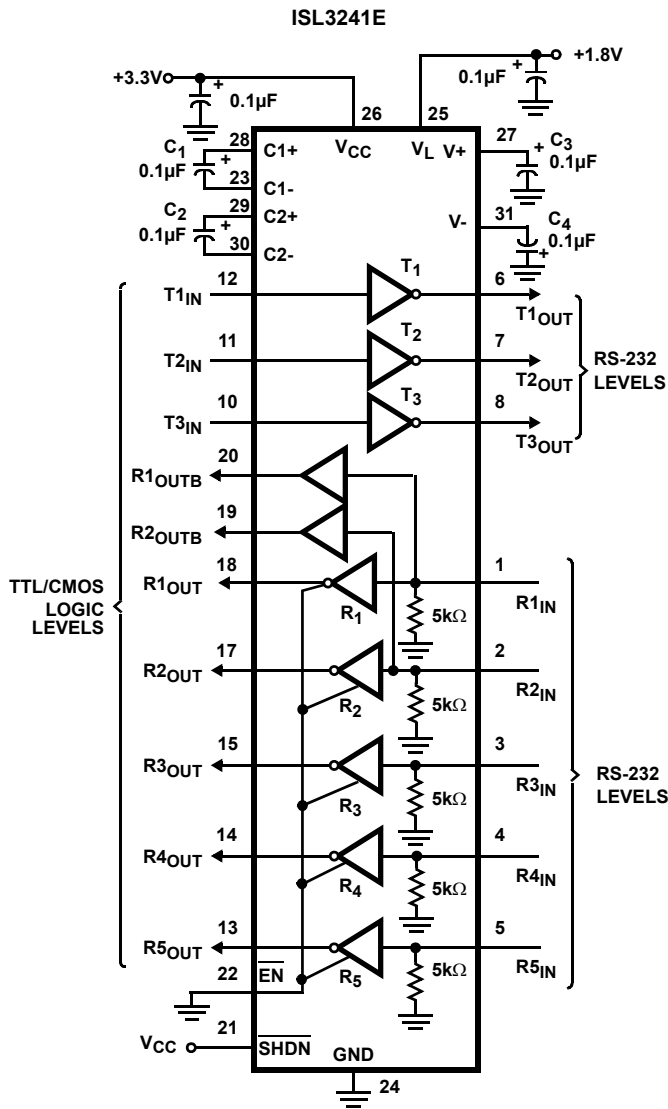

Absolute Maximum Ratings

V _{CC} to Ground	-0.3V to 6V
V _L to Ground	-0.3V to (V _{CC} + 0.3V)
V ₊ to Ground	-0.3V to 7V
V ₋ to Ground	+0.3V to -7V
V ₊ to V ₋	14V
Input Voltages	
T _{IN} , FORCEOFF, FORCEON, EN, SHDN	-0.3V to 6V
R _{IN}	±25V
Output Voltages	
T _{OUT}	±13.2V
R _{OUT} , INVALID	-0.3V to (V _L + 0.3V)
Short Circuit Duration	
T _{OUT}	Continuous
ESD Rating	See "ESD PERFORMANCE" on page 7

Thermal Information

Thermal Resistance (Typical, Notes 4, 5)	θ _{JA} (°C/W)	θ _{JC} (°C/W)
32 Ld QFN Package	32	1.8
Maximum Junction Temperature	+150°C	
Maximum Storage Temperature Range	-65°C to +150°C	
Pb-Free Reflow Profile	see link below http://www.intersil.com/pbfree/Pb-FreeReflow.asp	

Operating Conditions

Temperature Range	-40°C to +85°C
-------------------	----------------

CAUTION: Do not operate at or near the maximum ratings listed for extended periods of time. Exposure to such conditions may adversely impact product reliability and result in failures not covered by warranty.

NOTES:

- θ_{JA} is measured in free air with the component mounted on a high effective thermal conductivity test board with "direct attach" features. See Tech Brief [TB379](#) for details.
- For θ_{JC}, the "case temp" location is the center of the exposed metal pad on the package underside.

Electrical Specifications Test Conditions: V_{CC} = 3V to 3.6V, V_L = 1.8V ±10%, C₁ to C₄ = 0.1μF, Unless Otherwise Specified. Typical values are at T_A = +25°C, V_{CC} = 3.3V, V_L = 1.8V, Unless Otherwise Specified. **Boldface limits apply over the operating temperature range, -40°C to +85°C.**

PARAMETER	TEST CONDITIONS	TEMP (°C)	MIN (Note 6)	TYP	MAX (Note 6)	UNITS
DC CHARACTERISTICS						
Operating Voltage Range		Full	2.7	-	3.6	V
Supply Current, Automatic Powerdown	All R _{IN} Open, FORCEON = GND, FORCEOFF = V _L V _L = V _{CC} (ISL3243E Only)	Full	-	0.5	3	μA
Supply Current, Powerdown	All R _{IN} Open, FORCEOFF = SHDN = GND, V _L = V _{CC}	Full	-	0.5	3	μA
Supply Current, Automatic Powerdown Disabled	All Outputs Unloaded, FORCEON = FORCEOFF = SHDN = V _L , V _{CC} = V _L = 3.0V	25	-	0.3	1.0	mA
		Full	-	0.3	1.5	mA
LOGIC AND TRANSMITTER INPUTS; RECEIVER AND LOGIC OUTPUTS						
Input Logic Threshold Low	T _{IN} , FORCEON, FORCEOFF, EN, SHDN V _L = V _{CC} = 3V	Full	-	-	0.5	V
		Full	-	-	0.8	V
Input Logic Threshold High	T _{IN} , FORCEON, FORCEOFF, EN, SHDN V _L = V _{CC} = 3.6V	Full	1.25	-	-	V
		Full	2.0	-	-	V
Input Leakage Current	T _{IN} , FORCEON, FORCEOFF, EN, SHDN	Full	-	±0.01	±1.0	μA
Output Leakage Current	FORCEOFF = GND (ISL3243E) or EN = V _L (ISL3241E)	Full	-	±0.05	±1.0	μA
Output Voltage Low (See Figure 21)	I _{OUT} = 250μA, R _{OUT} , R _{OUTB} , INVALID	Full	-	-	0.45	V
	I _{OUT} = 1.6mA, V _L = V _{CC} , R _{OUT} , R _{OUTB} , INVALID	Full	-	-	0.4	V
Output Voltage High (See Figure 21)	I _{OUT} = -250μA, R _{OUT} , R _{OUTB} , INVALID	Full	V_L - 0.25	V _L - 0.1	-	V
	I _{OUT} = -1.0mA, V _L = V _{CC} , R _{OUT} , R _{OUTB} , INVALID	Full	V_L - 0.6	V _L - 0.1	-	V
AUTOMATIC POWERDOWN (ISL3243E Only, FORCEON = GND, FORCEOFF = V_L)						
Receiver Input Thresholds to Enable Transmitters	ISL3243E Powers Up (See Figure 10)	Full	-2.7	-	2.7	V
Receiver Input Thresholds to Disable Transmitters	ISL3243E Powers Down (See Figure 10)	Full	-0.3	-	0.3	V

Electrical Specifications Test Conditions: $V_{CC} = 3V$ to $3.6V$, $V_L = 1.8V \pm 10\%$, C_1 to $C_4 = 0.1\mu F$, Unless Otherwise Specified. Typical values are at $T_A = +25^\circ C$, $V_{CC} = 3.3V$, $V_L = 1.8V$, Unless Otherwise Specified. **Boldface limits apply over the operating temperature range, $-40^\circ C$ to $+85^\circ C$. (Continued)**

PARAMETER	TEST CONDITIONS	TEMP ($^\circ C$)	MIN (Note 6)	TYP	MAX (Note 6)	UNITS	
Receiver Threshold to Transmitters Enabled Delay (t_{WU})		25	-	20	-	μs	
Receiver Positive or Negative Threshold to INVALID High Delay (t_{INVH})		25	-	0.7	-	μs	
Receiver Positive or Negative Threshold to INVALID Low Delay (t_{INVL})		25	-	20	-	μs	
RECEIVER INPUTS							
Input Voltage Range		Full	-25	-	25	V	
Input Threshold Low	$V_{CC} \geq 2.7V$	Full	-	-	0.6	V	
	$V_{CC} \geq 3V$	Full	-	-	0.8	V	
Input Threshold High		Full	2.0	1.5	-	V	
Input Hysteresis		25	-	0.5	-	V	
Input Resistance		Full	3	5	7	$k\Omega$	
TRANSMITTER OUTPUTS							
Output Voltage Swing (V_O)	All Transmitter Outputs Loaded with $3k\Omega$ to Ground		Full	± 5.0	± 5.4	-	V
		$V_{CC} = 2.7V$	Full	± 4.0	± 4.7	-	V
Output Resistance	$V_{CC} = V_L = V+ = V- = 0V$, Transmitter Output = $\pm 2V$	Full	300	10M	-	Ω	
Output Short-Circuit Current		Full	-	± 35	± 60	mA	
Output Leakage Current	$V_{OUT} = \pm 12V$, $V_{CC} = V_L = 0V$ or $3V$ to $3.6V$, Automatic Powerdown or $\overline{FORCEOFF} = \overline{SHDN} = GND$	Full	-	-	± 25	μA	
TIMING CHARACTERISTICS							
Maximum Data Rate	$R_L = 3k\Omega$, $C_L = 1000pF$, One Transmitter Switching	Full	250	400	-	kbps	
	$R_L = 3k\Omega$, $C_L = 200pF$, $V_{CC} = 3.15V$, One Transmitter Switching	Full	-	1.3	-	Mbps	
Receiver Propagation Delay	Receiver Input to Receiver Output, $C_L = 30pF$, $R_{IN} = \pm 3V$ (See Figure 2)	t_{PHL}	25	-	0.23	0.55	μs
			Full	-	0.26	0.6	μs
		t_{PLH}	25	-	0.16	0.55	μs
			Full	-	0.18	0.6	μs
Receiver Skew	$ t_{PHL} - t_{PLH} $	25	-	70	300	ns	
		Full	-	80	350	ns	
Transmitter Propagation Delay	Transmitter Input to Transmitter Output, $C_L = 1000pF$, $R_L = 3k\Omega$ (See Figure 1) (Note 7)	t_{PHL}	25	-	0.7	1.5	μs
			Full	-	0.8	1.7	μs
		t_{PLH}	25	-	0.7	1.5	μs
			Full	-	0.8	1.7	μs
Transmitter Skew	$ t_{PHL} - t_{PLH} $	25	-	20	500	ns	
		Full	-	20	550	ns	
Receiver Output Enable Time	From \overline{EN} or $\overline{FORCEOFF}$, $V_L = V_{CC}$, $R_L = 1k\Omega$, $C_L = 15pF$ (See Figure 3)	25	-	120	-	ns	
Receiver Output Disable Time		25	-	200	-	ns	
Transmitter Output Enable Time From Powerdown	From \overline{SHDN} or $\overline{FORCEOFF}$, $R_L = 3k\Omega$, $C_L = 1000pF$	25	-	20	-	μs	

Electrical Specifications Test Conditions: $V_{CC} = 3V$ to $3.6V$, $V_L = 1.8V \pm 10\%$, C_1 to $C_4 = 0.1\mu F$, Unless Otherwise Specified. Typicals are at $T_A = +25^\circ C$, $V_{CC} = 3.3V$, $V_L = 1.8V$, Unless Otherwise Specified. **Boldface limits apply over the operating temperature range, $-40^\circ C$ to $+85^\circ C$. (Continued)**

PARAMETER	TEST CONDITIONS	TEMP (°C)	MIN (Note 6)	TYP	MAX (Note 6)	UNITS
Transition Region Slew Rate	$V_{CC} = 3V$ to $3.6V$, $R_L = 3k\Omega$ to $7k\Omega$, Measured From $3V$ to $-3V$ or $-3V$ to $3V$	25	4	12	30	$V/\mu s$
		25	6	18	30	$V/\mu s$
ESD PERFORMANCE						
RS-232 Pins (T_{OUT} , R_{IN})	Human Body Model	25	-	± 15	-	kV
	IEC61000-4-2 Contact Discharge	25	-	± 8	-	kV
	IEC61000-4-2 Air Gap Discharge	25	-	± 15	-	kV
All Pins	Human Body Model	25	-	± 2	-	kV
	Machine Model	25	-	± 200	-	V

NOTES:

- 6. Compliance to datasheet limits is assured by one or more methods: production test, characterization and/or design.
- 7. Transmitter propagation delays are measured at the transmitter output 0V crossing points.

Test Circuits and Waveforms

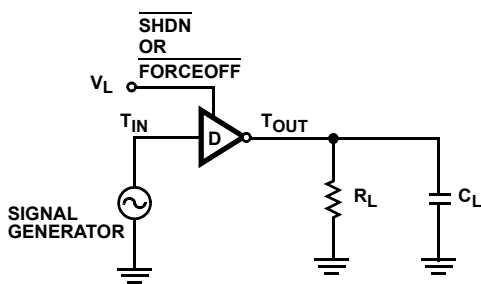

FIGURE 1A. TEST CIRCUIT

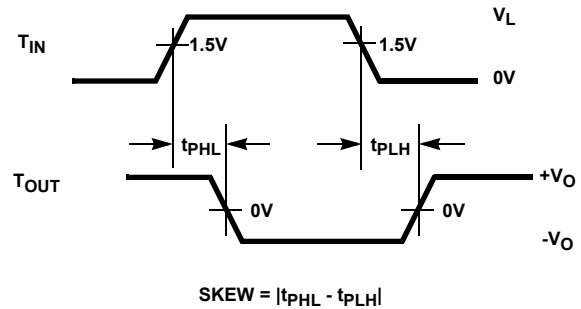

FIGURE 1B. MEASUREMENT POINTS

FIGURE 1. DRIVER PROPAGATION DELAY AND SKEW

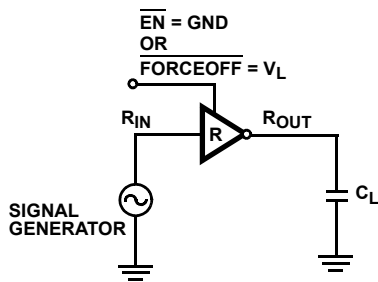

FIGURE 2A. TEST CIRCUIT

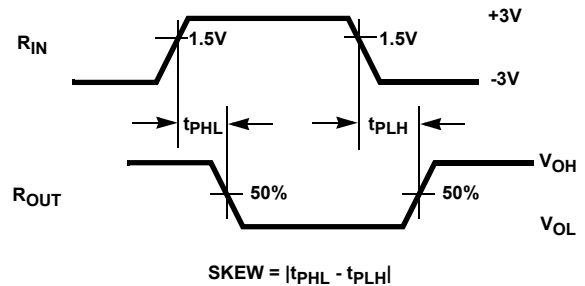
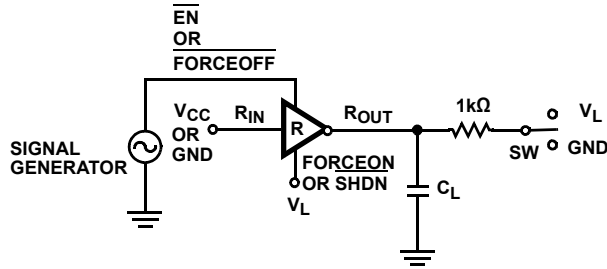

FIGURE 2B. MEASUREMENT POINTS

FIGURE 2. RECEIVER PROPAGATION DELAY AND SKEW

Test Circuits and Waveforms (Continued)



PARAMETER	R _{IN}	SW
t _{PHZ} and t _{PZH}	GND	GND
t _{PLZ} and t _{PLZ}	V _{CC}	V _L

FIGURE 3A. TEST CIRCUIT

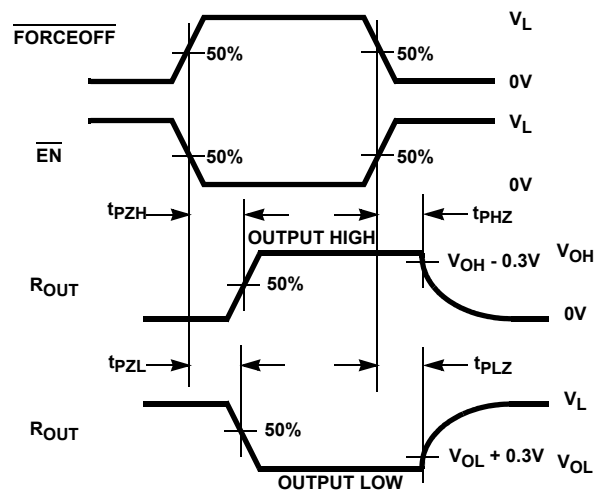

FIGURE 3B. MEASUREMENT POINTS

FIGURE 3. RECEIVER ENABLE AND DISABLE TIMES

Detailed Description

The ISL324xE operate from a single +2.7V to +3.6V supply, guarantee a 250kbps minimum data rate, require only four small external 0.1μF capacitors, feature low power consumption, and meet all EIA RS-232 and V.28 specifications even with V_{CC} = 3.0V. The circuit is divided into three sections: The charge pump, the transmitters, and the receivers.

Charge-Pump

Intersil's new ISL324xE devices utilize regulated on-chip dual charge pumps as voltage doublers, and voltage inverters to generate ±5.5V transmitter supplies from a V_{CC} supply as low as 3.0V. This allows them to maintain RS-232 compliant output levels over the ±10% tolerance range of 3.3V powered systems. The efficient on-chip power supplies require only four small, external 0.1μF capacitors for the voltage doubler and inverter functions. The charge pumps operate discontinuously (i.e., they turn off as soon as the V+ and V- supplies are pumped up to the nominal values), resulting in significant power savings.

Transmitters

The transmitters are proprietary, low dropout, inverting drivers that translate logic input levels to EIA/TIA-232 output levels. Coupled with the on-chip ±5.5V supplies, these transmitters deliver true RS-232 levels over a wide range of single supply system voltages.

All transmitter outputs disable and assume a high impedance state when the device enters the power-down mode (see Table 2). These outputs may be driven to F12V when disabled.

The devices guarantee a 250kbps data rate for full load conditions (3kΩ and 1000pF), V_{CC} ≥ 3.0V, with one transmitter operating at full speed. Under more typical conditions of V_{CC} ≥ 3.3V, R_L = 3kΩ and C_L = 200pF, one transmitter easily operates at greater than 1Mbps.

The transmitter input switching threshold is set by the voltage applied to the V_L pin, so tying V_L to a voltage lower than V_{CC} reduces the Tx input V_{IH} and V_{IL} to values compatible with logic ICs (e.g., UARTs and μcontrollers) powered by the V_L voltage (see Figure 9 and Table 3). Transmitter inputs float if left unconnected (there are no pull-up resistors), and may cause supply current increases. Connect unused inputs to GND for the best performance.

Receivers

All the ISL324xE devices contain standard inverting receivers that three-state via the $\overline{\text{EN}}$ or FORCEOFF control lines. Additionally, these products include noninverting “monitor” receivers (denoted by the R_{OUTB} label) that are always active, regardless of the state of any control lines. All the receivers convert RS-232 signals to CMOS output levels, swinging between GND and V_L, and accept inputs up to ±25V while presenting the required 3kΩ to 7kΩ input impedance (see Figure 4) even if the power is off (V_{CC} = 0V). The receivers' Schmitt trigger input stage uses hysteresis to increase noise immunity and decrease errors due to slow input signal transitions.

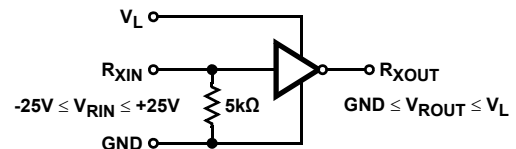

FIGURE 4. INVERTING RECEIVER CONNECTIONS

The ISL3241E inverting receivers disable only when $\overline{\text{EN}}$ is driven high. ISL3243E receivers disable during forced (manual) powerdown, but not during automatic powerdown (see Table 2).

TABLE 2. POWER-DOWN AND ENABLE LOGIC TRUTH TABLE (NOTE: "H" = V_L)

RS-232 SIGNAL PRESENT AT RECEIVER INPUT?	$\overline{\text{SHDN}}$ OR $\overline{\text{FORCEOFF}}$ INPUT	FORCEON INPUT	$\overline{\text{EN}}$ INPUT	TRANSMITTER OUTPUTS	RECEIVER OUTPUTS	R _{OUTB} OUTPUTS	$\overline{\text{INVALID}}$ OUTPUT	MODE OF OPERATION
ISL3241E								
N/A	L	N/A	L	High-Z	Active	Active	N/A	Manual Power-down
N/A	L	N/A	H	High-Z	High-Z	Active	N/A	Manual Power-down w/ Rcvr. Disabled
N/A	H	N/A	L	Active	Active	Active	N/A	Normal Operation
N/A	H	N/A	H	Active	High-Z	Active	N/A	Normal Operation w/ Rcvr. Disabled
ISL3243E								
NO	H	H	N.A.	Active	Active	Active	L	Normal Operation (Auto Powerdown Disabled)
YES	H	L	N.A.	Active	Active	Active	H	Normal Operation (Auto Power-down Enabled)
NO	H	L	N.A.	High-Z	Active	Active	L	Power-down Due to Auto Power-down Logic
YES	L	X	N.A.	High-Z	High-Z	Active	H	Manual Power-down
NO	L	X	N.A.	High-Z	High-Z	Active	L	Manual Power-down

ISL324xE monitor receivers remain active even during manual powerdown, making them extremely useful for Ring Indicator monitoring. Standard receivers driving powered down peripherals must be disabled to prevent current flow through the peripheral's protection diodes (see Figures 5 and 6). This renders them useless for wake up functions, but the corresponding monitor receiver can be dedicated to this task as shown in Figure 6.

Low Power Operation

These 3V devices require a nominal supply current of 0.3mA, even at $V_{CC} = 3.6V$, during normal operation (not in power-down mode). This is considerably less than the 5mA to 11mA current required by comparable 5V RS-232 devices, allowing users to reduce system power simply by switching to this new family.

Power-down Functionality

The already low current requirement drops significantly when the device enters powerdown mode. In powerdown, supply current drops to less than 1µA, because the on-chip charge pump turns off (V_+ collapses to V_{CC} , V_- collapses to GND), and the transmitter outputs three-state. Inverting receiver outputs disable only in manual powerdown (ISL3243E) or when $\overline{\text{EN}} = V_L$ (ISL3241E); refer to Table 2 for details. This micro-power mode makes the ISL324xE ideal for battery powered and portable applications.

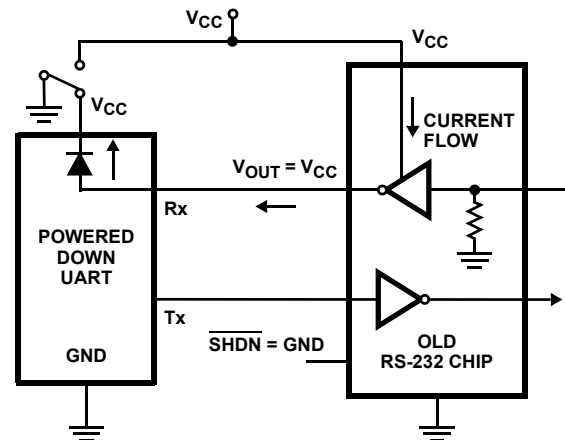

FIGURE 5. POWER DRAIN THROUGH POWERED DOWN PERIPHERAL

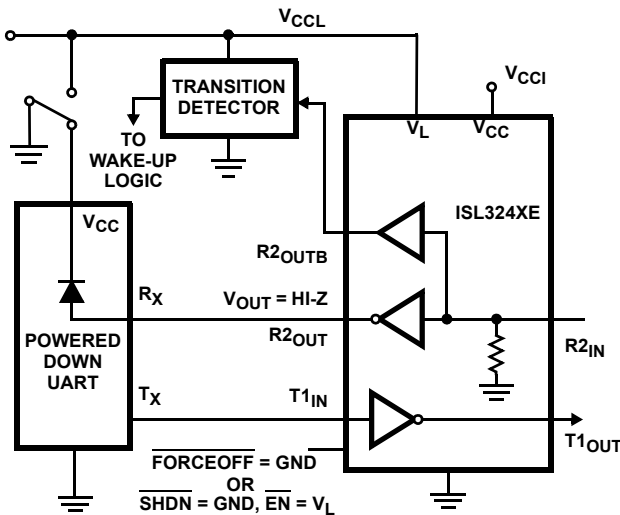

FIGURE 6. DISABLED RECEIVERS PREVENT POWER DRAIN

Software Controlled (Manual) Powerdown

The devices in this family provide pins that allow the user to force the IC into the low power, standby state.

On the ISL3241E, the powerdown control is via a simple shutdown ($\overline{\text{SHDN}}$) pin. Driving this pin high enables normal operation, while driving it low forces the IC into its powerdown state. Connect $\overline{\text{SHDN}}$ to V_L if the powerdown function isn't needed. Note that all the receiver outputs remain controlled by $\overline{\text{EN}}$ during shutdown (see Table 2). For the lowest power consumption during powerdown, the receivers should also be disabled by driving the $\overline{\text{EN}}$ input high (see next section, and Figures 5 and 6).

The ISL3243E utilizes a two pin approach where the FORCEON and FORCEOFF inputs determine the IC's mode. For always enabled operation, FORCEON and FORCEOFF are both strapped high. To switch between active and powerdown modes, under logic or software control, only the $\overline{\text{FORCEOFF}}$ input need be driven. The FORCEON state isn't critical, as $\overline{\text{FORCEOFF}}$ dominates over FORCEON. Nevertheless, if strictly manual control over powerdown is desired, the user must strap FORCEON high to disable the automatic powerdown circuitry. ISL3243E inverting (standard) receiver outputs also disable when the device is in manual powerdown, thereby eliminating the possible current path through a shutdown peripheral's input protection diode (see Figures 5 and 6).

Connecting $\overline{\text{FORCEOFF}}$ and FORCEON together disables the automatic powerdown feature, enabling them to function as a manual SHUTDOWN input (see Figure 7).

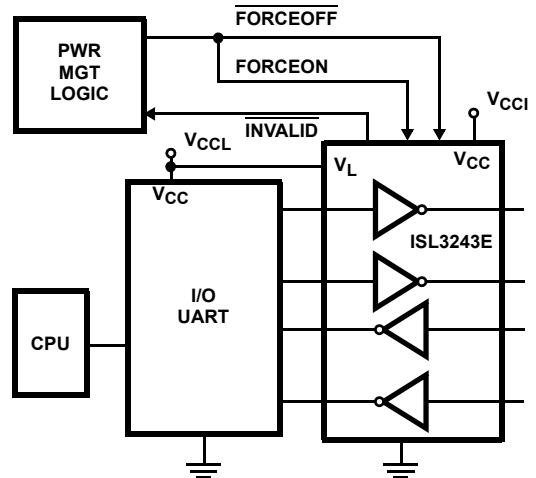

FIGURE 7. CONNECTIONS FOR MANUAL POWERDOWN WHEN NO VALID RECEIVER SIGNALS ARE PRESENT

With any of the previous mentioned control schemes, the time required to exit powerdown, and resume transmission is only 20 μs . A mouse, or other application, may need more time to wake up from shutdown. If automatic power-down is being utilized, the RS-232 device will reenter power-down if valid receiver levels aren't reestablished within 20 μs of the ISL3243E powering up. Figure 8 illustrates a circuit that keeps the ISL3243E from initiating automatic power-down for 100ms after powering up. This gives the slow-to-wake peripheral circuit time to reestablish valid RS-232 output levels.

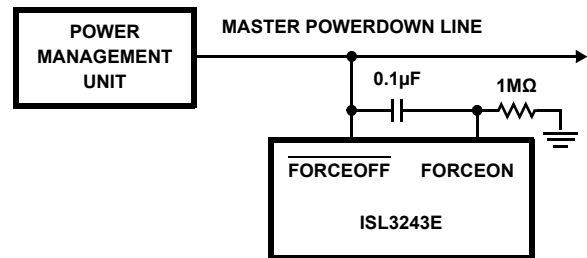

FIGURE 8. CIRCUIT TO PREVENT AUTO POWERDOWN FOR 100ms AFTER FORCED POWERUP

V_L Logic Supply Input

Note: If V_L isn't connected to the V_{CC} supply, power-up V_{CC} before powering up the V_L supply.

The ISL324xE feature a V_L pin that powers the logic input and output pins. These pins interface with "logic" devices such as UARTs, ASICs, and μ controllers, and today most of these devices use power supplies significantly lower than 3.3V. Thus, the logic device's low V_{OH} might not exceed the V_{IH} of a 3.3V powered ISL324xE logic input, or a 3.3V receiver output high level might overdrive and damage the input diodes on an input of a 1.8V powered logic device, as shown in Figure 9. Connecting the V_L pin to the power supply of the logic device (see Figure 9) reduces the ISL324xE's logic input switching points, and limits the receiver output high voltage, to values compatible with the logic device's I/O levels. Tailoring the ISL324XE's logic pin input switching points and output levels

to the supply voltage of the UART, ASIC, or μ controller eliminates the need for a level shifter/translator between the two ICs.

TABLE 3. V_{IH} AND V_{IL} vs V_L FOR $V_{CC} = 3.3V$

V_L (V)	V_{IH} (V)	V_{IL} (V)
1.6	0.85	0.8
1.8	0.95	0.9
2.5	1.25	1.2

V_L may range from 1.6V to V_{CC} , and Table 3 indicates the ISL324xE's typical V_{IH} and V_{IL} levels for several V_L values. Note that the V_L supply current increases significantly when V_L exceeds V_{CC} (see Figure 20).

If logic translation isn't required, connect V_L to V_{CC} .

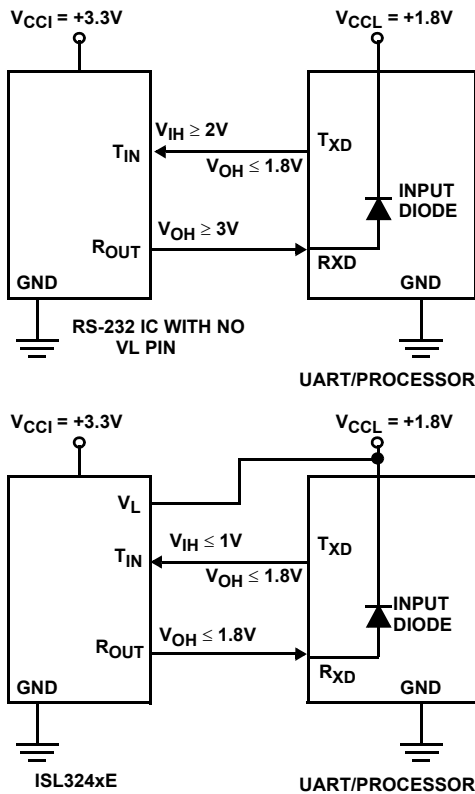

FIGURE 9. USING V_L PIN TO ADJUST LOGIC LEVELS

INVALID Output (ISL3243E Only)

The $\overline{INVALID}$ output always indicates whether or not a valid RS-232 signal (see Figure 10) is present at any of the receiver inputs (see Table 2), giving the user an easy way to determine when the interface block should power down. Invalid receiver levels occur whenever the driving peripheral's outputs are shut off (powered down) or when the RS-232 interface cable is disconnected. In the case of a disconnected interface cable where all the receiver inputs are floating (but pulled to GND by the internal receiver pull down resistors), the $\overline{INVALID}$ logic detects the invalid levels and drives the output low. The power management logic then uses this indicator to power-down the interface block. Reconnecting the cable restores valid levels at

the receiver inputs, $\overline{INVALID}$ switches high, and the power management logic wakes up the interface block. $\overline{INVALID}$ can also be used to indicate the DTR or RING INDICATOR signal, as long as the other receiver inputs are floating, or driven to GND (as in the case of a powered down driver).

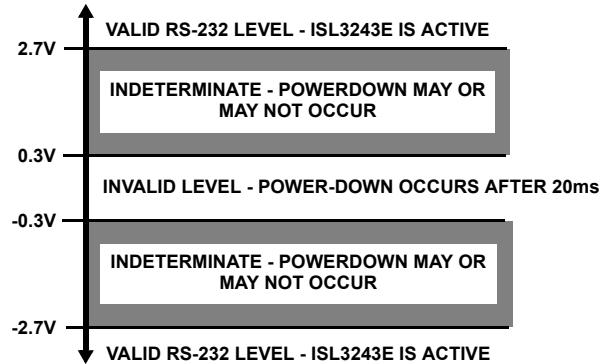

FIGURE 10. DEFINITION OF VALID RS-232 RECEIVER LEVELS

$\overline{INVALID}$ switches low after invalid levels have persisted on all of the receiver inputs for more than 20 μ s (see Figure 11). $\overline{INVALID}$ switches back high 1 μ s after detecting a valid RS-232 level on a receiver input. $\overline{INVALID}$ operates in all modes (forced or automatic power-down, or forced on), so it is also useful for systems employing manual power-down circuitry. When automatic powerdown is utilized, $\overline{INVALID} = 0$ indicates that the ISL3243E is in powerdown mode.

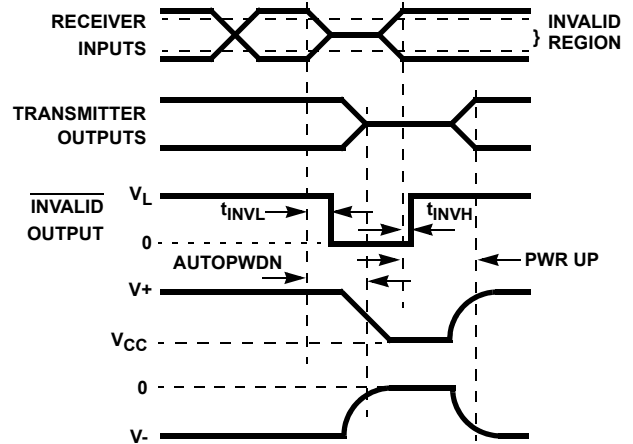

FIGURE 11. AUTOMATIC POWERDOWN AND $\overline{INVALID}$ TIMING DIAGRAMS

Automatic Power-down (ISL3243E Only)

Even greater power savings is available by using the ISL3243E which features an automatic power-down function. When no valid RS-232 voltages (see Figure 11) are sensed on any receiver input for 20 μ s, the charge pump and transmitters power-down, thereby reducing supply current to less than 1 μ A. Invalid receiver levels occur whenever the driving peripheral's outputs are shut off (powered down) or when the RS-232 interface cable is disconnected. The ISL3243E powers back up whenever it detects a valid RS-232 voltage level on any receiver input. This automatic power-down feature provides

additional system power savings without changes to the existing operating system.

Automatic power-down operates when the FORCEON input is low, and the FORCEOFF input is high. Tying FORCEON high disables automatic power-down, but manual powerdown is always available via the overriding FORCEOFF input. Table 2 summarizes the automatic power-down functionality.

The time to recover from automatic power-down mode is typically 20µs.

Capacitor Selection

The charge pumps require 0.1µF, or greater, capacitors for proper operation. Increasing the capacitor values (by a factor of 2) reduces ripple on the transmitter outputs and slightly reduces power consumption.

When using minimum required capacitor values, make sure that capacitor values do not degrade excessively with temperature. If in doubt, use capacitors with a larger nominal value. The capacitor's equivalent series resistance (ESR) usually rises at low temperatures and it influences the amount of ripple on V+ and V-.

Power Supply Decoupling

In most circumstances a 0.1µF bypass capacitor is adequate. In applications that are particularly sensitive to power supply noise, decouple V_{CC} and V_L to ground with a capacitor of the same value as the charge-pump capacitor C₁. Connect the bypass capacitor as close as possible to the IC.

Transmitter Outputs when Exiting Power-down

Figure 12 shows the response of two transmitter outputs when exiting powerdown mode. As they activate, the two transmitter outputs properly go to opposite RS-232 levels, with no glitching, ringing, nor undesirable transients. Each transmitter is loaded with 3kΩ in parallel with 1000pF. Note that the transmitters enable only when the magnitude of V+ and V- exceeds approximately 3V.

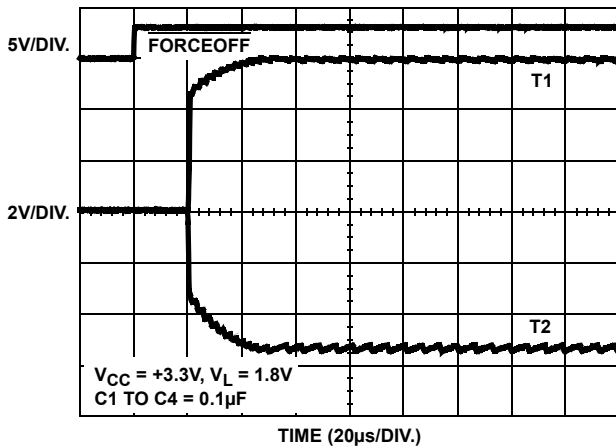

FIGURE 12. TRANSMITTER OUTPUTS WHEN EXITING POWERDOWN

Operation Down to 2.7V

ISL324xE transmitter outputs meet RS-562 levels (±3.7V), at the full data rate, with V_{CC} as low as 2.7V. RS-562 levels typically ensure inter operability with RS-232 devices.

High Data Rates

The ISL324xE maintain the RS-232 ±5V minimum transmitter output voltages even at high data rates. Figure 13 details a transmitter loopback test circuit, and Figure 14 illustrates the loopback test result at 120kbps. For this test, all transmitters were simultaneously driving RS-232 loads in parallel with 1000pF, at 120kbps. Figure 15 shows the loopback results for a single transmitter driving 1000pF and an RS-232 load at 250kbps. The static transmitters were also loaded with an RS-232 receiver.

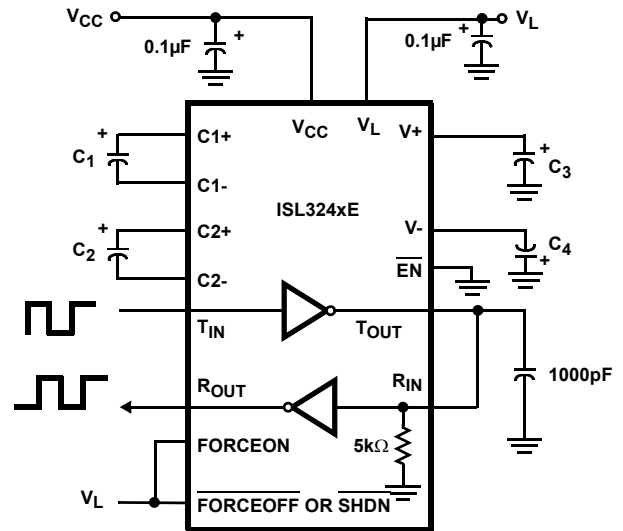

FIGURE 13. TRANSMITTER LOOPBACK TEST CIRCUIT

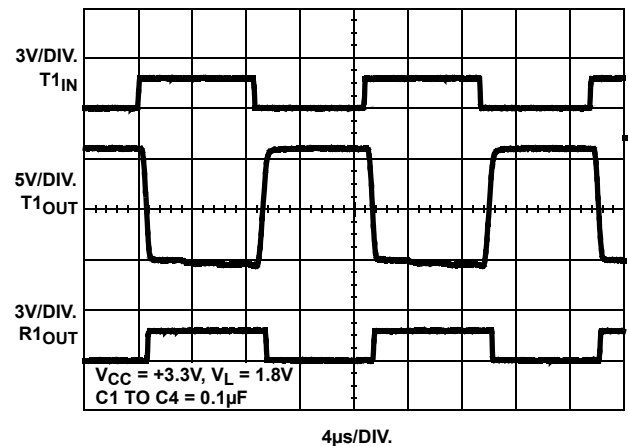

FIGURE 14. LOOPBACK TEST AT 120kbps

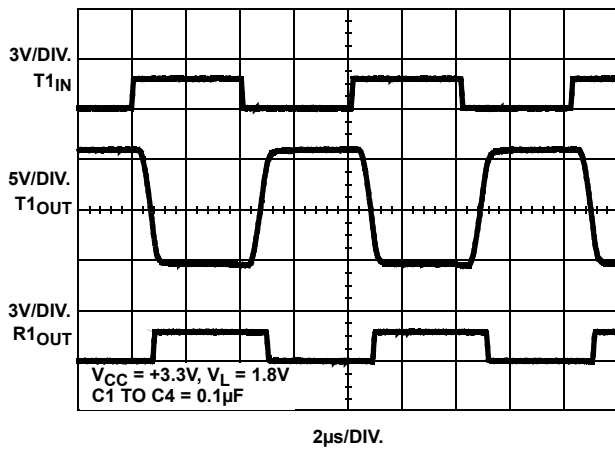

FIGURE 15. LOOPBACK TEST AT 250kbps

Interconnection to 1.8V, and 2.5V Logic

Standard 3.3V powered RS-232 devices interface well with 3V powered TTL compatible logic families (e.g., ACT and HCT).

The ISL324xE V_L supply pin allows interconnection to 1.8V or 2.5V logic. By connecting V_L to the same supply (1.8V or 2.5V) powering the logic device, the ISL324XE logic outputs will swing from GND to the logic V_{CC} .

±15kV ESD Protection

All pins on ISL324xE devices include ESD protection structures, but the RS-232 pins (transmitter outputs and receiver inputs) incorporate advanced structures which allow them to survive ESD events up to ±15kV. The RS-232 pins are particularly vulnerable to ESD damage because they typically connect to an exposed port on the exterior of the finished product. Simply touching the port pins, or connecting a cable, can cause an ESD event that might destroy unprotected ICs. These new ESD structures protect the device whether or not it is powered up, protect without allowing any latchup mechanism to activate, and don't interfere with RS-232 signals as large as ±25V.

Human Body Model (HBM) Testing

As the name implies, this test method emulates the ESD event delivered to an IC during human handling. The tester delivers the charge through a 1.5kΩ current limiting resistor, making the test less severe than the IEC61000 test which utilizes a 330Ω limiting resistor. The HBM method determines an IC's ability to withstand the ESD transients typically present during handling and manufacturing. Due to the random nature of these events, each pin is tested with respect to all other pins. The RS-232 pins on "E" family devices can withstand HBM ESD events to ±15kV.

IEC61000-4-2 Testing

The IEC61000 test method applies to finished equipment, rather than to an individual IC. Therefore, the pins most likely to suffer an ESD event are those that are exposed to the outside world (the RS-232 pins in this case), and the IC is tested in its typical application configuration (power applied) rather than testing each pin-to-pin combination. The lower current limiting resistor coupled with the larger charge storage capacitor yields a test that is much more severe than the HBM test. The extra ESD protection built into this device's RS-232 pins allows the design of equipment meeting level 4 criteria without the need for additional board level protection on the RS-232 port.

AIR-GAP DISCHARGE TEST METHOD

For this test method, a charged probe tip moves toward the IC pin until the voltage arcs to it. The current waveform delivered to the IC pin depends on approach speed, humidity, temperature, etc., so it is difficult to obtain repeatable results. The "E" device RS-232 pins withstand ±15kV air-gap discharges.

CONTACT DISCHARGE TEST METHOD

During the contact discharge test, the probe contacts the tested pin before the probe tip is energized, thereby eliminating the variables associated with the air-gap discharge. The result is a more repeatable and predictable test, but equipment limits prevent testing devices at voltages higher than ±8kV. All "E" family devices survive ±8kV contact discharges on the RS-232 pins.

Typical Performance Curves $V_{CC} = 3.3V, V_L = 1.8V, T_A = +25^\circ C$

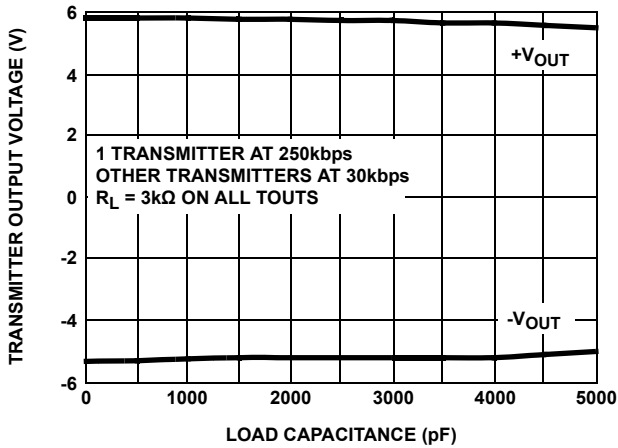

FIGURE 16. TRANSMITTER OUTPUT VOLTAGE vs LOAD CAPACITANCE

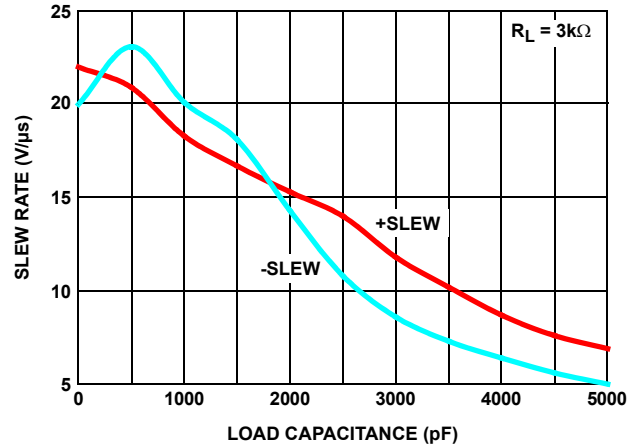

FIGURE 17. SLEW RATE vs LOAD CAPACITANCE

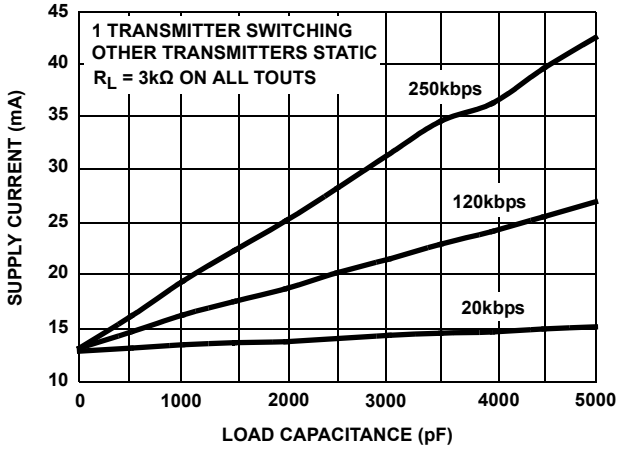

FIGURE 18. SUPPLY CURRENT vs LOAD CAPACITANCE WHEN TRANSMITTING DATA

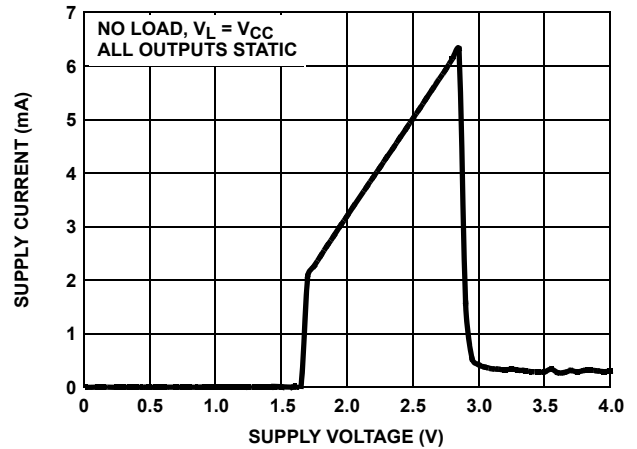

FIGURE 19. SUPPLY CURRENT vs SUPPLY VOLTAGE

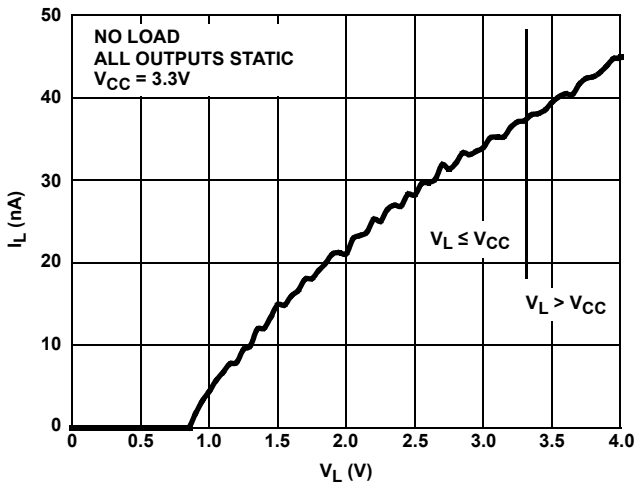

FIGURE 20. V_L SUPPLY CURRENT vs V_L VOLTAGE

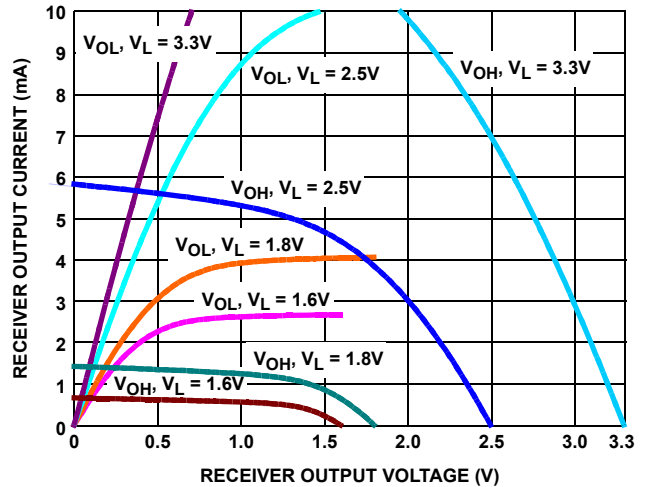

FIGURE 21. RECEIVER OUTPUT CURRENT vs RECEIVER OUTPUT VOLTAGE

Die Characteristics

SUBSTRATE AND QFN THERMAL PAD POTENTIAL (POWERED UP):

GND

TRANSISTOR COUNT:

464

PROCESS:

SI GATE BICMOS

© Copyright Intersil Americas LLC 2008-2012. All Rights Reserved.
All trademarks and registered trademarks are the property of their respective owners.

For additional products, see www.intersil.com/en/products.html

Intersil products are manufactured, assembled and tested utilizing ISO9001 quality systems as noted in the quality certifications found at www.intersil.com/en/support/qualandreliability.html

Intersil products are sold by description only. Intersil may modify the circuit design and/or specifications of products at any time without notice, provided that such modification does not, in Intersil's sole judgment, affect the form, fit or function of the product. Accordingly, the reader is cautioned to verify that datasheets are current before placing orders. Information furnished by Intersil is believed to be accurate and reliable. However, no responsibility is assumed by Intersil or its subsidiaries for its use; nor for any infringements of patents or other rights of third parties which may result from its use. No license is granted by implication or otherwise under any patent or patent rights of Intersil or its subsidiaries.

For information regarding Intersil Corporation and its products, see www.intersil.com

Package Outline Drawing

L32.5x5B

32 LEAD QUAD FLAT NO-LEAD PLASTIC PACKAGE

Rev 2, 11/07

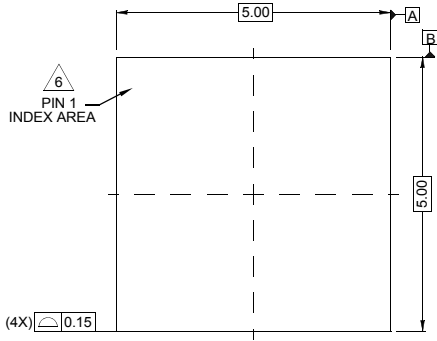

TOP VIEW

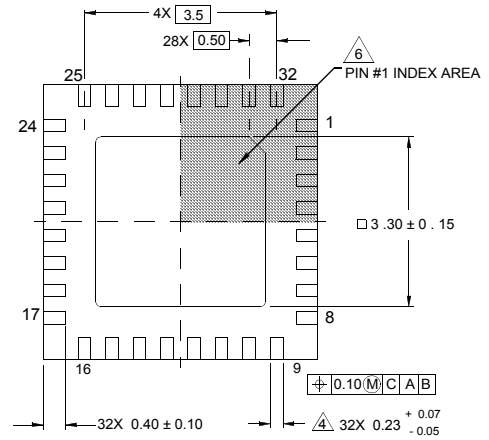

BOTTOM VIEW

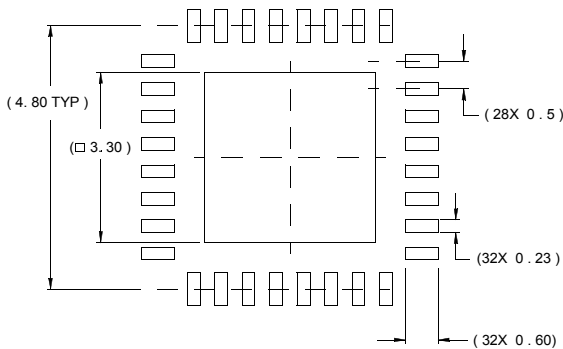

TYPICAL RECOMMENDED LAND PATTERN

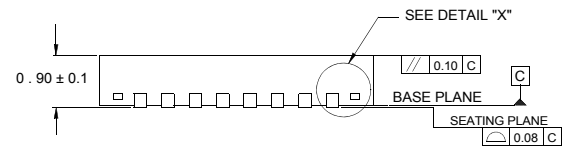

SIDE VIEW

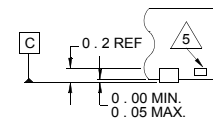

DETAIL "X"

NOTES:

1. Dimensions are in millimeters.
Dimensions in () for Reference Only.
2. Dimensioning and tolerancing conform to AMSE Y14.5m-1994.
3. Unless otherwise specified, tolerance: Decimal ± 0.05
4. Dimension b applies to the metallized terminal and is measured between 0.15mm and 0.30mm from the terminal tip.
5. Tiebar shown (if present) is a non-functional feature.
6. The configuration of the pin #1 identifier is optional, but must be located within the zone indicated. The pin #1 identifier may be either a mold or mark feature.