

ULI-227D5 ULI-227D3 ULI-227TL

BB-232LPTTL
BB-232LPTTL33
BB-232CL9R

Port-powered RS-232 to TTL & Current Loop Converters



Features

- Convert RS-232 to TTL (Transistor Transistor Logic) or current loop (by model)
- Baud rates: up to 115.2 kbps
- In-line installation
- RS-232 to 5V TTL or 3.3V TTL (model#s ULI-227D5 or ULI-227D3)
- Isolated RS-232 to active or passive 20 mA current loop (model# ULI-227TL)
- Port-powered or external power (by model)

Introduction

Advantech's ULI-227TL is an RS-232 to current loop converter. Its port-powering is adequate for passive loop installations; a PSU (sold separately) is required for an active loop. Advantech ULI-227D5 and ULI-227D3 TTL/CMOS adapters convert two channels (TX and RX) in each direction (bi-directional) from RS-232 to TTL/CMOS signals and vice versa. Powered from RS-232 data and handshake lines. Use with micro-controllers, programmable logic controllers (PLCs) and other devices that support TTL.

Specifications

Serial Technology

Model:	RS-232 Connector:	TTL Connector:	Current Loop Connector:	Data Rate, max:
ULI-227D5	DB9 female	DB9 male	–	115.2 kbps
ULI-227D3		–	Terminal block	19.2 kbps
ULI-227TL		–	Terminal block	19.2 kbps

TTL Technology

Model:	TTL Signals:	TTL Logic:	TTL Vdc Level:	Data Rate, max:
ULI-227D5	(2) Input	CMOS*	5 V	115.2 kbps
ULI-227D3	(2) Output Ground		3.3 V	

*IMPORTANT: Only TTL/CMOS logic (0 to +5 Vdc for model# ULI-227D5 and 0 to +3.3 Vdc for model# ULI-227D3) can be used for the TTL/CMOS converter side. Maximum sinking current for one TTL/CMOS output is 3.2 mA. Maximum source current for one TTL/CMOS is 1 mA. Signal levels are inverted by converter.

Power

- Port Power RS-232 data/handshake lines

Model:	Source:	Connector:	Input Voltage:	Power Consumption:
ULI-227D5 ULI-227D3	Port-power	–	–	<40 mA, max.
ULI-227TL*	Port-power OR external PSU	Terminal block	External PSU option: 12 Vdc @ 100mA	

*When the converter must provide the loop current, a 12 Vdc PSU (sold separately) is required to generate an active loop for current loop side. No external power is required for passive loop installations.

Mechanical

Model:	Enclosure:	Installation:	Dimensions, mm:	Weight, gm:
ULI-227D5	Plastic	Inline	52.9 x 33.3 x 17.4	36
ULI-227D3			83.0 x 56.0 x 16.9	25
ULI-227TL			83.0 x 56.0 x 16.9	25

Meantime Between Failures (MTBF)

- Calculation Method MIL217F Parts Count Reliability Prediction

Model:	MTBF, hours:
ULI-227D5	5833353
ULI-227D3	1674682
ULI-227TL	714354

Environmental

- Operating Temperature 0 to +70 °C
- Storage Temperature -40 to +85 °C
- Operating Humidity 95%, non-condensing

Regulatory/Approvals/Certifications

Model #:	Approvals:	CE Directives:	CE Standards:
ULI-227D5	FCC Part 15, Class B Emissions, CE	2014/30/EU – Electromagnetic Compatibility (EMC)	EN 55032 (Class B) – Electromagnetic Compatibility of Multimedia Equipment – Emission Requirements
ULI-227D3		2011/65/EU – amended by (EU) 2015/863 Reduction of Hazardous Substances (RoHS)	EN 55024 - Information Technology Equipment – Immunity Characteristics – Limits and Methods of Measurement
ULI-227TL	FCC Part 15, Class A Emissions, CE	2012/19/EU – Waste Electrical and Electronic Equipment (WEEE)	–

Dimensions - ULI-227D5, ULI-227D3

Unit = mm / in

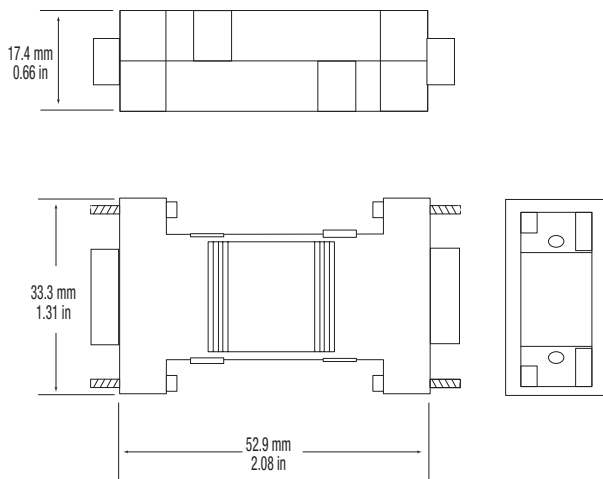

Dimensions - ULI-227TL

Unit = mm / in

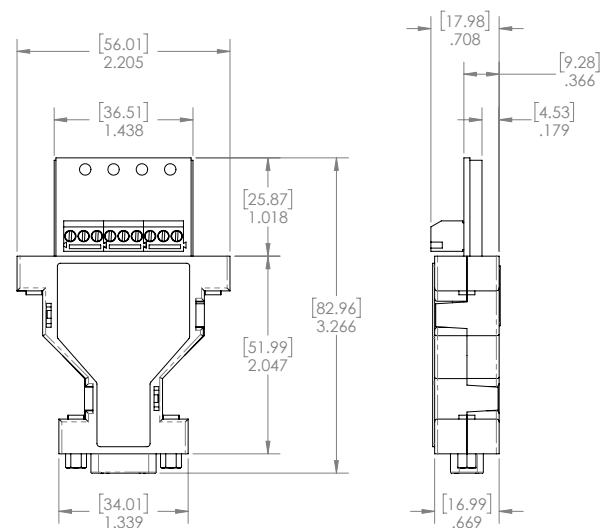

Ordering Information

Model	Part Number to Order	Description
ULI-227D5	BB-232LP TTL	RS-232 DB9F to 5V TTL DB9M Converter, 115.2kbps, Port-powered.
ULI-227D3	BB-232LP TTL33	RS-232 DB9F to 3.3V TTL DB9M Converter, 115.2kbps, Port-powered.
ULI-227TL	BB-232CL9R	RS-232 DB9F to 20mA Current Loop TB Converter, 19.2kbps, Port-powered or external PSU (sold separately).

ULI-227 Series Selection Guide

Port-powered RS-232 to TTL & Current Loop Converters



Common Features

- Convert RS-232 to TTL (Transistor Transistor Logic) or current loop (by model)
- Baud rates: up to 115.2 kbps
- In-line installation
- RS-232 to 5V TTL or 3.3V TTL (model#s ULI-227D5 or ULI-227D3)
- Isolated RS-232 to active or passive 20 mA current loop (model# ULI-227TL)
- Port-powered or external power (by model)

Port-powered TTL & Current Loop Converters Comparison Table

Model Number	ULI-227D5	ULI-227D3	ULI-227TL
Part Number to Order	BB-232LPTTL	BB-232LPTTL33	BB-232CL9R
Description	Port-powered, RS-232 to TTL & Current Loop Converters		
Key Features	RS-232 to 5 Vdc TTL	RS-232 to 3.3 Vdc TTL	RS-232 to 20 mA Current Loop
Industrial Rating	Light		
RS-232 Connector	DB9 female		
Conversion Signal Type	5 Vdc TTL (CMOS logic)	3.3 Vdc TTL (CMOS logic)	20 mA current loop
Connector Type	DB9 male		Terminal block
Data Rate, max.	115.2 kbps		19.2 kbps
Operating Temperature	0 to +70 °C		
Power Source	Port-power (RS-232 handshake lines)		Port-power or external PSU
Power Input Voltage	-		External PSU: 12 Vdc
Power Connector	-		External PSU: terminal block
Power Consumption, max.	<40 mA		
Enclosure	Plastic		
Mounting Installation	In-line		
Dimensions, mm	52.9 x 33.3 x 17.4		70.0 x 55.2 x 16.5
MTBF (MIL217F), hours	5833353	1674682	714354
Regulatory/Approvals/ Certifications	FCC Part 15, Class B Emissions, CE		FCC Part 15, Class A Emissions, CE
	2014/30/EU – Electro-magnetic Compatibility (EMC) 2011/65/EU – amended by (EU) 2015/863 Reduction of Hazardous Substances (RoHS) 2012/19/EU – Waste Electrical and Electronic Equipment (WEEE)		
	EN 55032 (Class B) – Electromagnetic Compatibility of Multimedia Equipment – Emission Requirements EN 55024 – Information Technology Equipment – Immunity Characteristics – Limits and Methods of Measurement		-