

Using the EVAL-AD4110-1SDZ Universal Input Analog Front End for Industrial Process Control Systems

FEATURES

- Full-featured evaluation board for the [AD4110-1](#)
- PC control in conjunction with Analog Devices, Inc., SDP PC software for control
- Compatible with Windows 7, Windows 8, and Windows 10

EVALUATION BOARD KIT CONTENTS

- EVAL-AD4110-1SDZ evaluation board
- 4 green screw block connectors, attached to the evaluation board
- 2 plastic screws and washers to bolt the [EVAL-SDP-CB1Z](#) to the EVAL-AD4110-1SDZ evaluation board

ADDITIONAL HARDWARE REQUIRED

- [EVAL-SDP-CB1Z \(SDP-B\)](#) controller board
- USB cable included

ADDITIONAL SOFTWARE REQUIRED

- Windows 7, Windows 8, or Windows 10

GENERAL DESCRIPTION

The EVAL-AD4110-1SDZ evaluates the features of the [AD4110-1](#) analog front end (AFE). The software executable file of the PC controls the [AD4110-1](#) via USB through the system demonstration platform (SDP) board. The [SDP-B](#) board controls the evaluation board and can be connected to the USB port of any PC running Windows® 7, Windows 8, or Windows 10-based operating system using the [AD4110-1](#) evaluation software.

The [AD4110-1](#) is a complete, single-channel, universal input, analog-to-digital front end for industrial process control systems where sensor type flexibility is required.

The high voltage input is fully software configurable for current or voltage ranges and allow direct interface to all standard industrial analog signal sources, such as ± 20 mA, ± 4 mA to ± 20 mA, ± 10 V, and all thermocouple types. Field power can be supplied for loop powered current output sensors. A range of excitation current sources for resistance temperature detector (RTD) sensors and other resistive sensors are included. The integrated programmable gain amplifier (PGA) offers sixteen gain settings from 0.2 to 24.

EVAL-AD4110-1SDZ FUNCTIONAL BLOCK DIAGRAM

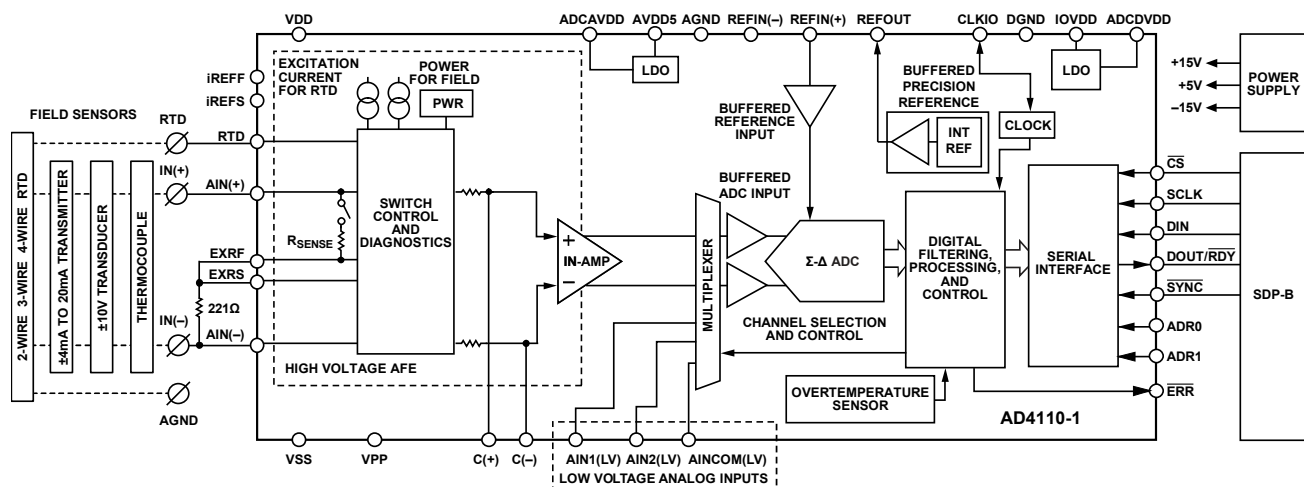

Figure 1.

TABLE OF CONTENTS

Features	1	Evaluation Board Power-Up	5
Evaluation Board Kit Contents	1	Software Installation	5
Additional Hardware Required	1	Evaluation Board Software	8
Additional Software Required	1	Hardware and Drivers	8
General Description	1	Launching the Software	8
EVAL-AD4110-1SDZ Functional Block Diagram	1	Evaluation Software Main Window	9
Revision History	2	Overview of the Main Window	9
Evaluation Board Hardware	3	Main Window—Voltage Mode Tab	10
EVAL-AD4110-1SDZ Basic Hardware Setup	3	Main Window—Histogram Tab	12
Evaluation Board Schematic Location	3	Main Window—Thermocouple Mode	13
Power Supplies	3	Main Window—RTD Mode	14
Connectors and Link Options	4	Main Window—Current Mode	15
Default Link Option Setup	4	Manual Configuration of Registers	16
LED Indicators	4	Default Mode of Operation at Power-Up	17
Evaluation Board Software Quick Start Procedures	5		

REVISION HISTORY

3/2019—Revision 0: Initial Version

EVALUATION BOARD HARDWARE

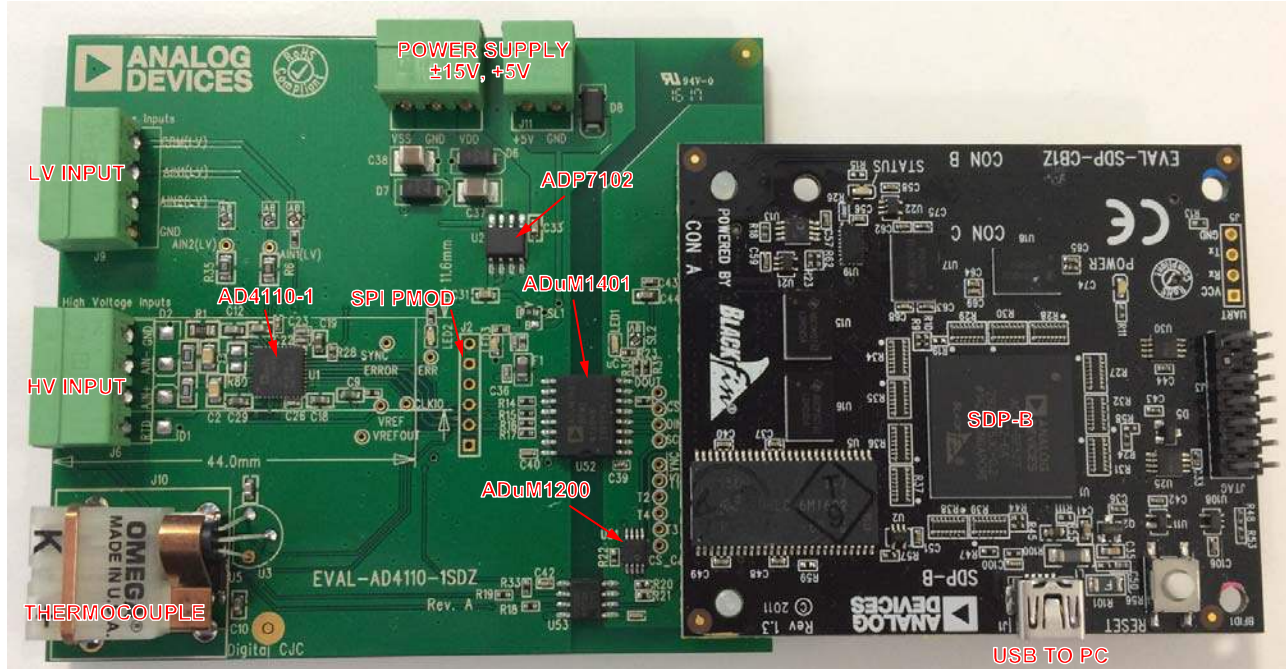

Figure 2. Hardware Configuration—Setting Up the EVAL-AD4110-1SDZ

EVAL-AD4110-1SDZ BASIC HARDWARE SETUP

The EVAL-AD4110-1SDZ evaluation board connects to the [SDP-B](#) controller board, which is the communication link between the PC and the evaluation board. Connect the EVAL-AD4110-1SDZ board to Connector A (CON A) on the [SDP-B](#) board, as shown in Figure 2.

EVALUATION BOARD SCHEMATIC LOCATION

The evaluation board schematic diagram is included with the supporting documentation located on the EVAL-AD4110-1SDZ product page.

POWER SUPPLIES

The EVAL-AD4110-1SDZ requires external voltage supplies.

A ± 15 V power supply is recommended and must be connected to J14, as shown in Figure 2.

The following are acceptable power supply configurations:

- Connect +15 V to the VDD pin.
- Connect -15 V to the VSS pin.
- Connect 0 V to the GND pin.

The 5 V supply required on EVAL-AD4110-1SDZ evaluation board is generated on-board where the 15 V supply is applied to the [ADP7102](#) low dropout regulator (LDO).

The [SDP-B](#) board is powered via USB.

The [SDP-B](#) board communicates to the EVAL-AD4110-1SDZ board through the serial interface, which spans across the [ADuM1401](#) and [ADuM1200](#) isolator devices. The [SDP-B](#) board is powered from the USB connection to the PC and the logic on the [SDP-B](#) board is 3.3 V. The EVAL-AD4110-1SDZ board runs off a 5 V digital rail, which is applied to the hot side of the isolator.

CONNECTORS AND LINK OPTIONS

Set the link options on the evaluation board for the required operating setup before using the board. The functions of the link options are described in Table 1.

DEFAULT LINK OPTION SETUP

The default link options are listed in Table 1. By default, the board is configured to operate from an external VDD and VSS supplies. The 5 V supply required for the [AD4110-1](#) is

generated by the on-board LDO ([ADP7102](#)), which takes the 15 V VDD supply as the input and generates the 5 V supply.

Table 2 describes the external connectors on the EVAL-AD4110-1SDZ evaluation board.

LED INDICATORS

Table 3 describes the LED indicators on the EVAL-AD4110-1SDZ evaluation board.

Table 1. Default Link and Solder Link Options

Link No.	Position	Description
SL1	A (default)	Connects the 5 V output of the ADP7102 to the DVDD rail to supply the IOVDD pins of the AD4110-1 .
	B	Connects an external 3.3 V and 5 V supplies to the DVDD rail to supply the IOVDD pins of the AD4110-1 .
SL2	A (default)	Valid SDP connection to evaluation board LED.
	B	Reserved.
SL3	A (default)	Connects J8 AINCOM to Pin 26 (AINCOM(LV)) of the AD4110-1 .
	B	Connects the 2.5 V voltage reference (V_{REF}) to Pin 26 (AINCOM(LV)) of the AD4110-1 .
SL4	A (default)	Connects GND to Pin 28 (AIN2(LV)) of the AD4110-1 .
	B	Connects J8 AIN2(LV) to Pin 28 (AIN2(LV)) of the AD4110-1 .
SL5	A (default)	Connects VOUT of the TMP36 temperature sensor to Pin 27 (AIN1(LV)) of the AD4110-1 .
	B	Connects J8 AIN1(LV) to Pin 27 (AIN1(LV)) of the AD4110-1 .

Table 2. On-Board Connectors

Connector	Function
J14	Power supply block. Apply VDD, VSS, and GND supplies to power the EVAL-AD4110-1SDZ board.
J12	Used to externally supply DVDD for the IOVDD and AVDD5 pins (optional).
J6	High voltage universal input.
J8	Low voltage inputs (analog-to-digital converter only).
J10	Thermocouple input.
J1	120-pin connector to mate with the SDP-B board.
J2	Serial peripheral interface (SPI) PMOD (1 = \overline{CS} , 2 = DIN, 3 = DOUT, 4 = SCLK, 5 = GND, 6 = 5 V external power supply from J12).

Table 3. On-Board Indicators

Connector	Color	Function
LED1	Green	Indicates valid SDP connection to the evaluation board.
LED2	Red	Indicates an error condition occurred on the analog input channel monitored by the AFE or an analog-to-digital (ADC) overrange error.
LED3	Green	Indicates 5 V supply to the EVAL-AD4110-1SDZ board.

EVALUATION BOARD SOFTWARE QUICK START PROCEDURES

EVALUATION BOARD POWER-UP

To power up the evaluation board, take the following steps:

1. Install the EVAL-AD4110-1SDZ software. Do not connect the SDP-B board to the PC until this software is installed. The PC must be restarted after the installation.
2. Connect the SDP-B board to the EVAL-AD4110-1SDZ board.
3. Screw these two boards together with the enclosed plastic screws and washers to ensure that the boards connect firmly together.
4. Apply the external voltage ($\pm 12\text{ V}$ to $\pm 20\text{ V}$) to the power supply connector of the EVAL-AD4110-1SDZ board as shown in Figure 2.
5. Connect the SDP-B board to the PC with the USB cable.
6. From **Start**, select **Programs > Analog Devices > AD4110-1_SDZ**, and then **AD4110-1**. The main window of the software displays.
7. From the main window menu bar, select the required demo mode configuration, as shown in Figure 3.
8. The demo mode register configuration file automatically downloads to the AD4110-1.
9. Connect the required sensor.
10. Click **Sample** to display the acquired sensor signal waveform.

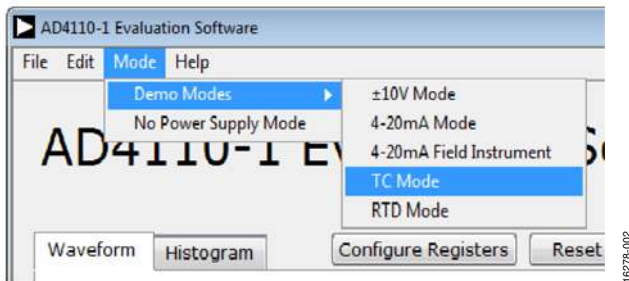

Figure 3. Demo Modes Dropdown Menu

SOFTWARE INSTALLATION

Install the evaluation software before connecting the evaluation board and SDP-B board to the USB port of the PC to ensure that the evaluation system is recognized successfully when connected to the PC.

The EVAL-AD4110-1SDZ evaluation software is compatible with Windows® 7, Windows 8, and Windows 10 operating systems.

There are two steps to the software installation, as follows:

- EVAL-AD4110-1SDZ board software installation (see Figure 4 to Figure 8).
- SDP-B board drivers installation (see Figure 9 to Figure 13).

Installing the AD4110-1 Evaluation Board Software

To install the AD4110-1 evaluation board software, take the following steps:

1. Ensure that the SDP-B board is disconnected from the USB port of the PC and unzip the evaluation software zip file.
2. Double-click the **setup.exe** file to begin the evaluation board software installation.
3. A dialog box may appear asking for permission to allow program changes to the PC (see Figure 4). Click **Yes**.

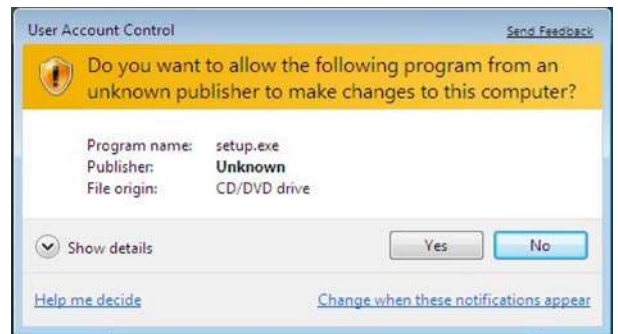

Figure 4. User Account Control Window

4. The installer initialization window appears briefly (see Figure 5).

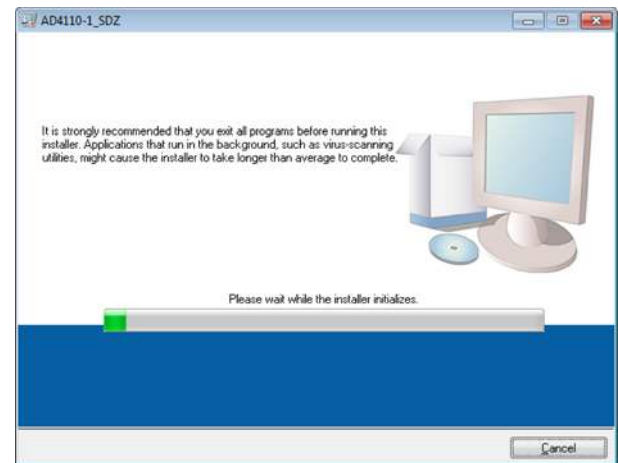

Figure 5. Installer Initialization Window

5. Select the location to install the software and click **Next>>**. To select another location, click **Browse...** (see Figure 6).

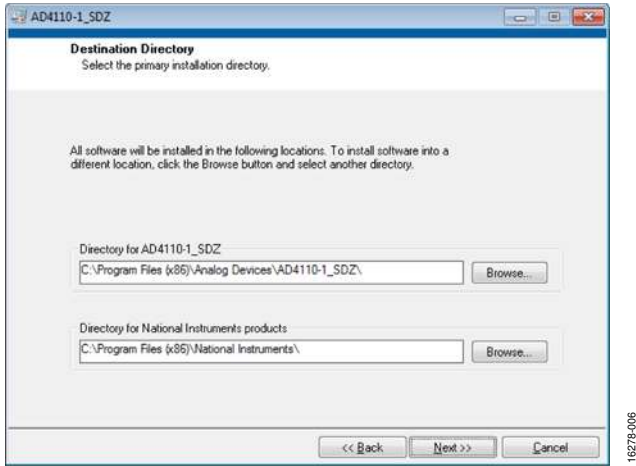

Figure 6. File Location Selection Window

8. A dialog box informs the user when the installation is complete. Click **Next>>** (see Figure 8).

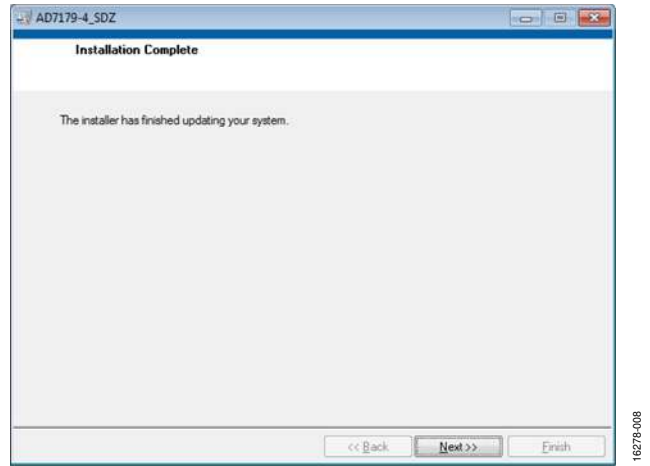

Figure 8. Installation Status Window

6. A license agreement may appear. Read the agreement and select **I accept the License Agreement** and click **Next>>**.
7. A summary of the installation is displayed. Click **Next>>** to continue (see Figure 7).

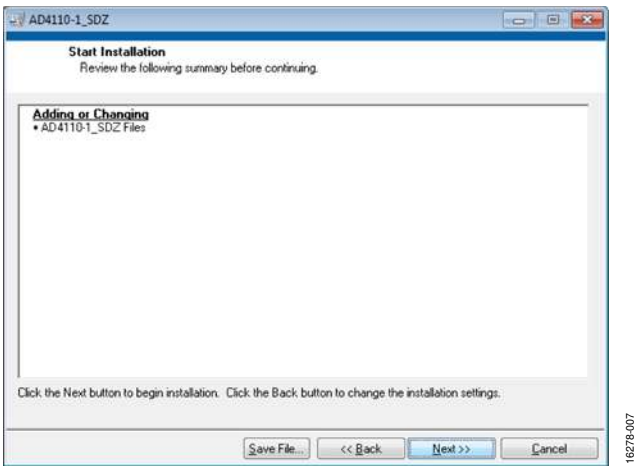

Figure 7. Installation Summary Window

Installing the SDP-B Board Drivers

When the evaluation software installation is complete, a welcome window is displayed for the installation of the SDP-B board drivers.

Take the following steps to install the SDP-B drivers.

1. Ensure that the SDP-B board is disconnected from the USB port of the PC and that all other applications are closed, and then click **Next>>** (see Figure 9).



Figure 9. SDP Drivers Setup Wizard

2. Select the location to install the drivers and click **Install** (see Figure 10).

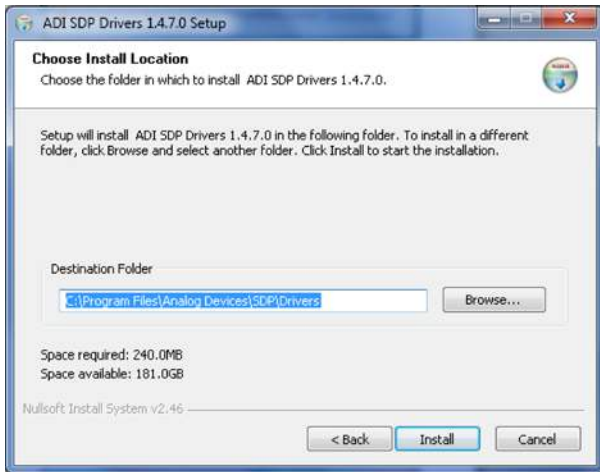

Figure 10. SDP Drivers Installation Location Window

3. An installation confirmation window may appear. Click **Install** to confirm driver installation (see Figure 11).

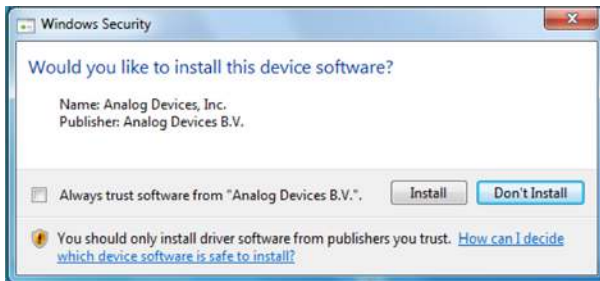

Figure 11. Installation Confirmation Window

4. Click **Finish** to complete the drivers installation (see Figure 12).



Figure 12. Installation Completion Window

5. Restart the PC before using the evaluation board (see Figure 13).

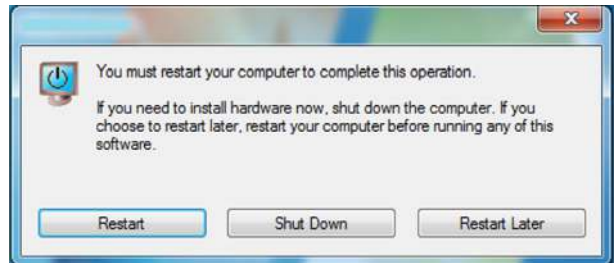

Figure 13. PC Restart Window

EVALUATION BOARD SOFTWARE HARDWARE AND DRIVERS

To install the evaluation board hardware and drivers, take the following steps:

1. When both software installations are complete, power up the **AD4110-1** evaluation board as described in the Evaluation Board Hardware section.
2. Ensure that the **SDP-B** board is connected to the **AD4110-1** and the USB port of the PC via the USB cable.
3. The user can also check if the **SDP-B** board is connecting to the PC properly by using the **Device Manager** of the PC.
4. Access the **Device Manager** as follows:
 - a. Click **Start, Control Panel**, and then click **Device Manager**.
 - b. A dialog box can appear asking permission to allow the program to make changes to the PC. Click **Yes**.
 - c. The **Device Manager** window appears.
 - d. Select **ADI Development Tools** (see Figure 14).
 - e. The **SDP-B** board appears under **ADI Development Tools** option, indicating that the driver software is installed and that the board is successfully connected to the PC.

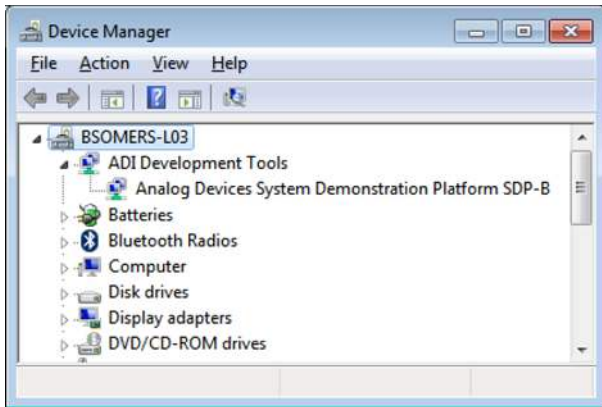

Figure 14. **Device Manager** Window

16278-014

LAUNCHING THE SOFTWARE

To launch the evaluation software, take the following steps:

1. Click **Start, All Programs, Analog Devices, AD4110-1_SDZ**, then **AD4110-1**. The main window of the software displays (see Figure 17).
2. If the evaluation system is not connected to the USB port when the software is launched, a connectivity error displays (see Figure 15). Connect the evaluation board to the USB port of the PC, wait a few seconds, click **Rescan**, and follow the instructions on the screen.

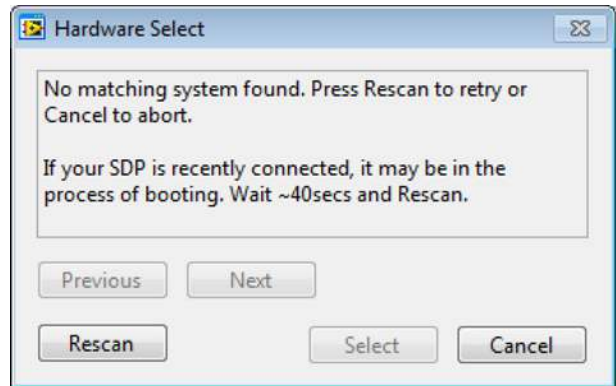

Figure 15. **Connectivity Error Alert**

16278-015

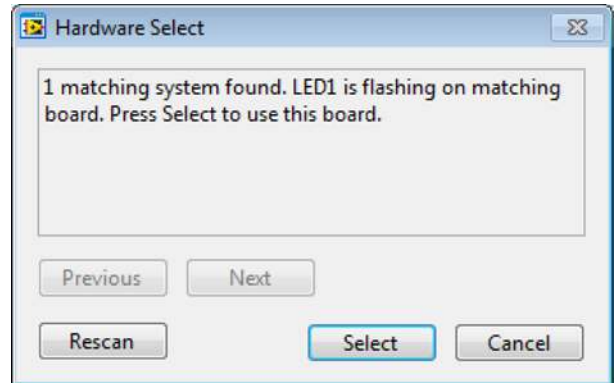

Figure 16. **Connectivity Confirmation**

16278-016

EVALUATION SOFTWARE MAIN WINDOW

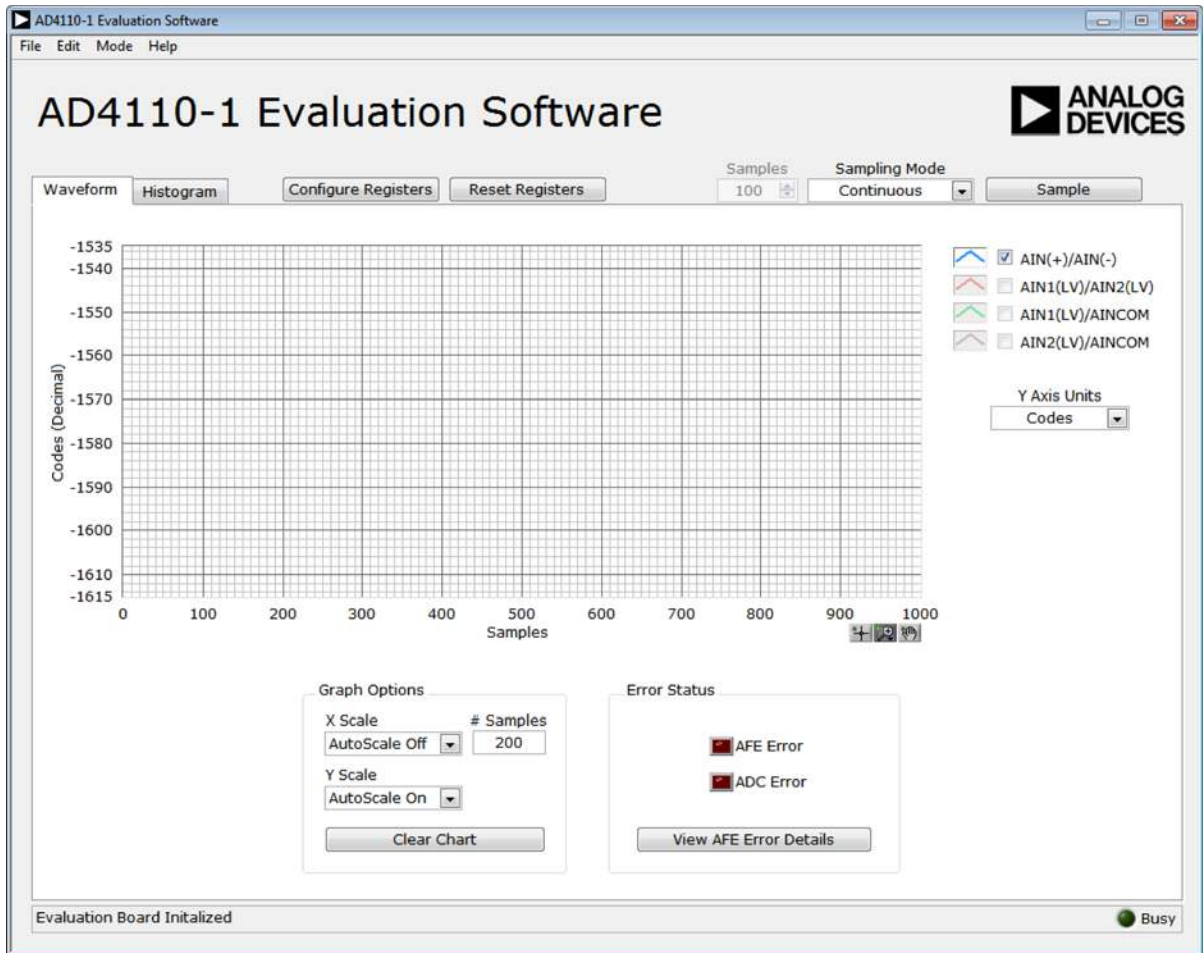

Figure 17. AD4110-1 Evaluation Software Main Window

OVERVIEW OF THE MAIN WINDOW

The main window (Figure 17) shows the significant control buttons and indicators of the AD4110-1 evaluation board software. Using the demonstration modes automatically configures the AD4110-1 device for connection to one of the sensors. The main window functionality adapts to the chosen demonstration mode.

The available demonstration modes are as follows:

- ± 10 V transducer
- 4 mA to 20 mA transmitter
- 4 mA to 20 mA transmitter that requires field power
- Thermocouple
- 3-wire RTD

Demo Modes

In the main window menu bar, click **Mode**, and then **Demo Modes**, and select the type of sensor connected to the input (see Figure 3).

The evaluation software and the AD4110-1 device are configured for the connected sensor.

Click **Sample** to begin sampling. To capture a defined number of samples, select **Single Capture** from the **Sampling Mode** dialog box and set the required number of samples in the **Samples** dialog box.

MAIN WINDOW—VOLTAGE MODE TAB

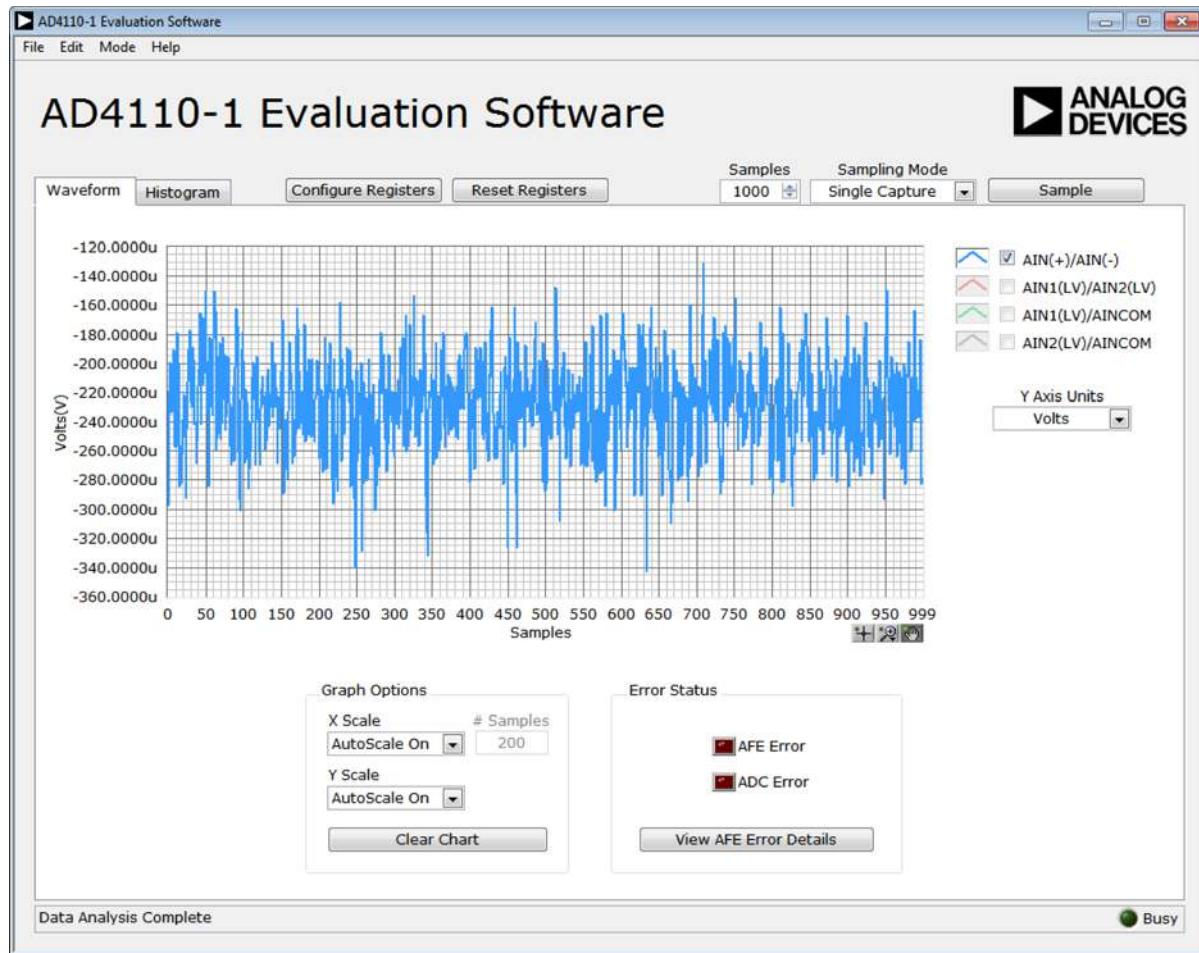

Figure 18. Voltage Mode Waveform Tab

Sampling Controls

Click **Sample** to begin sampling. Captured data is displayed on the waveform graph in the **Waveform** tab. The **Sampling Mode** dropdown menu specifies whether the software performs a single capture of the number of samples specified by the user in the **Samples** setting, or continuously, one sample at a time. In single capture mode, the number of samples is taken at the set output data rate. In continuous mode, only one sample is taken at a time and the time interval is determined by the PC and operating system. The **Samples** field specifies the number of samples per capture.

Waveform Graph

The waveform graph displays each successive sample captured from the ADC input. All enabled channels can be shown in the waveform plot. To remove any undesired channel(s) from the graph, deselect that channel within the graph legend.

Error Status Pane

The LED icons in the **Error Status** pane indicate an ADC or AFE error. Click **View AFE Error Status** to launch a dialog box that shows the detailed status for the high voltage channel (see Figure 19 and Figure 20).

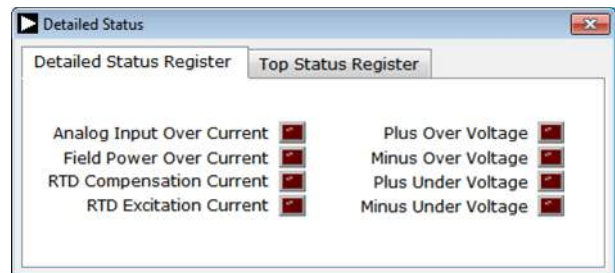

Figure 19. Error Details—Detailed Status Register Tab

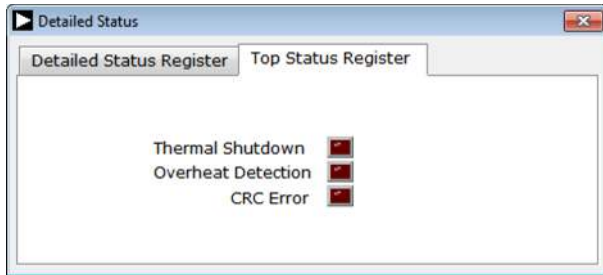

Figure 20. Error Details—**Top Status Register** Tab

Graph Options Pane

Y Scale and **X Scale** settings are used to enable or disable the autoscale function in each axis. When autoscale is disabled for the x-axis, a second **X Scale** setting (**# Samples**) specifies the number of data points to display in the x-axis. The **Y Scale** setting allows the user to choose what units are used for the y-axis.

MAIN WINDOW—HISTOGRAM TAB

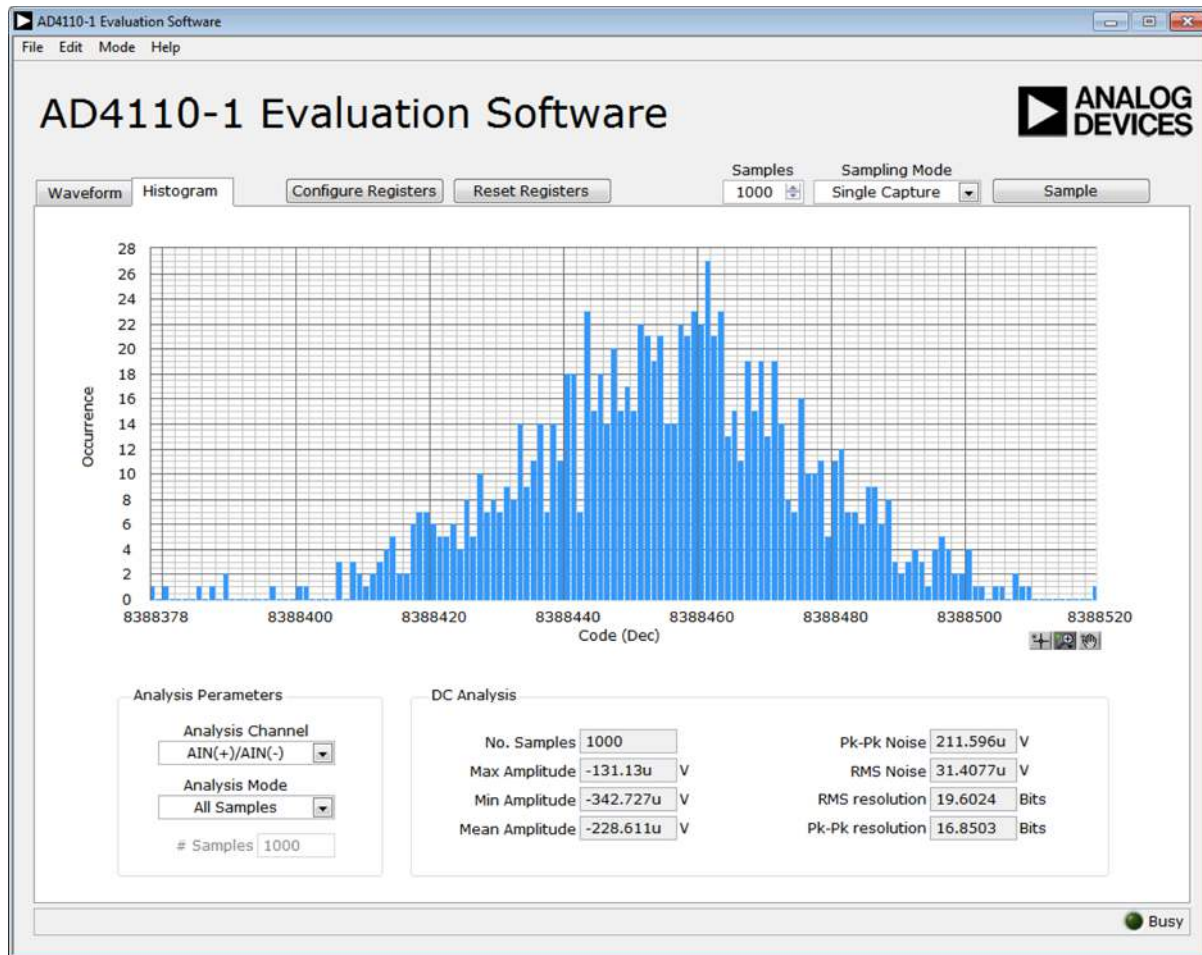

Figure 21. Histogram Tab

Histogram Tab

Figure 21 shows the contents of the **Histogram** tab. This graph plots codes vs. occurrence and can be used to test the ADC for code distribution.

DC Analysis Pane

This pane displays histogram analysis (mean, maximum, and minimum values) along with respective peak-to-peak and rms noise values.

Analysis Parameters Pane

The **Analysis Channel** dropdown menu specifies what channel the analysis is performed for. The **Analysis Mode** and **# Samples** dropdown menus allow the user to select the data set to analyze. These menus can be set to analyze all captured data or analyze a subset of the captured data containing the last number of samples specified by the **# Samples** setting.

MAIN WINDOW—THERMOCOUPLE MODE

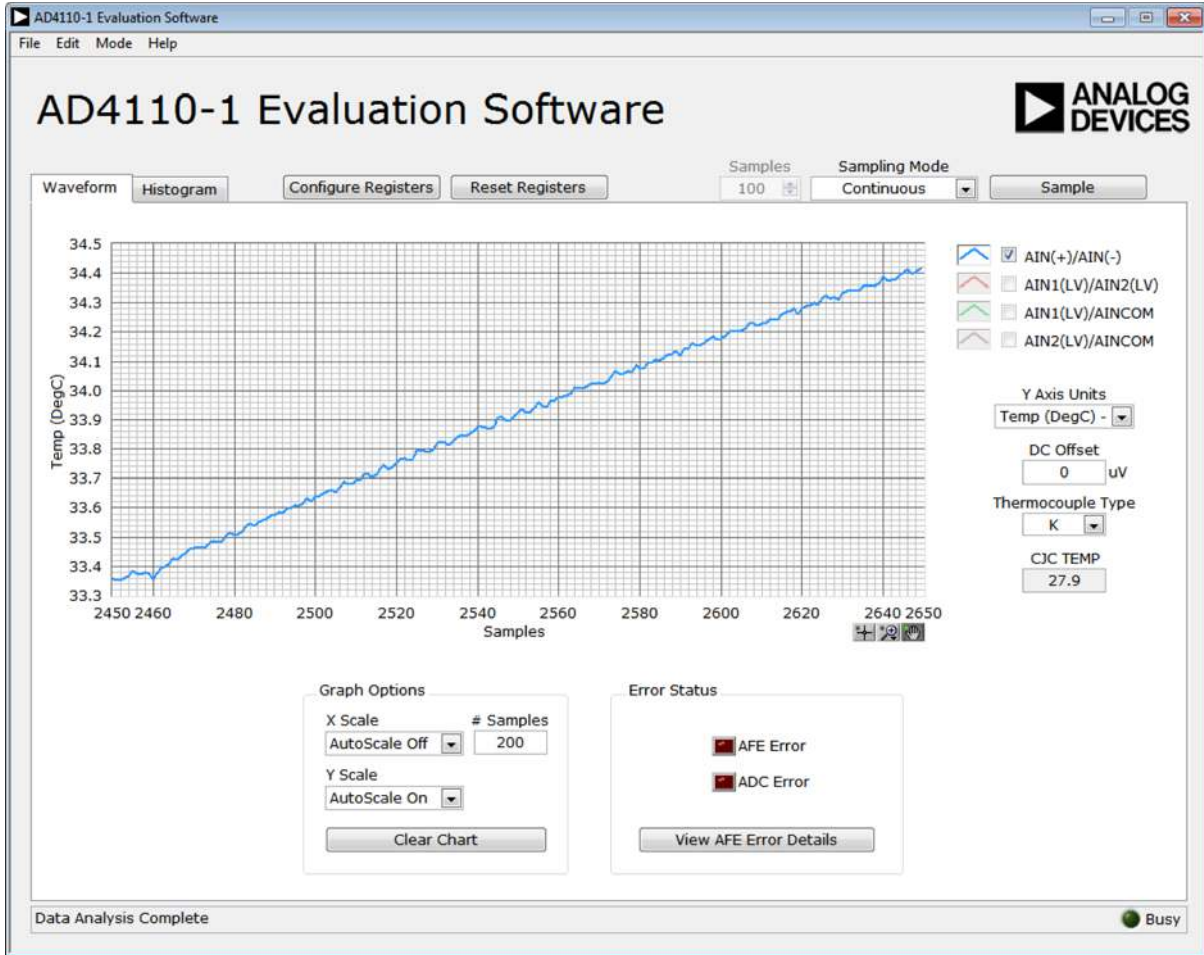

Figure 22. Thermocouple Mode

Y-Axis Units for Thermocouple Mode

When the thermocouple demo mode (TC Mode, see Figure 3) is selected, the y-axis units of the waveform display automatically change to temperature (degrees Celsius).

DC Offset for Thermocouple Mode

Any dc offset can be compensated for. The value entered in the DC Offset text box is subtracted from the ADC conversion result.

Thermocouple Type Setting

This dropdown menu allows the user to select the thermocouple type, and the corresponding temperature coefficient is used to calculate the displayed temperature.

CJC TEMP

There is a digital temperature sensor (U5) placed underneath the thermocouple connector. This sensor is used for cold junction compensation (CJC). The value shown in the CJC TEMP field shows temperature.

MAIN WINDOW—RTD MODE

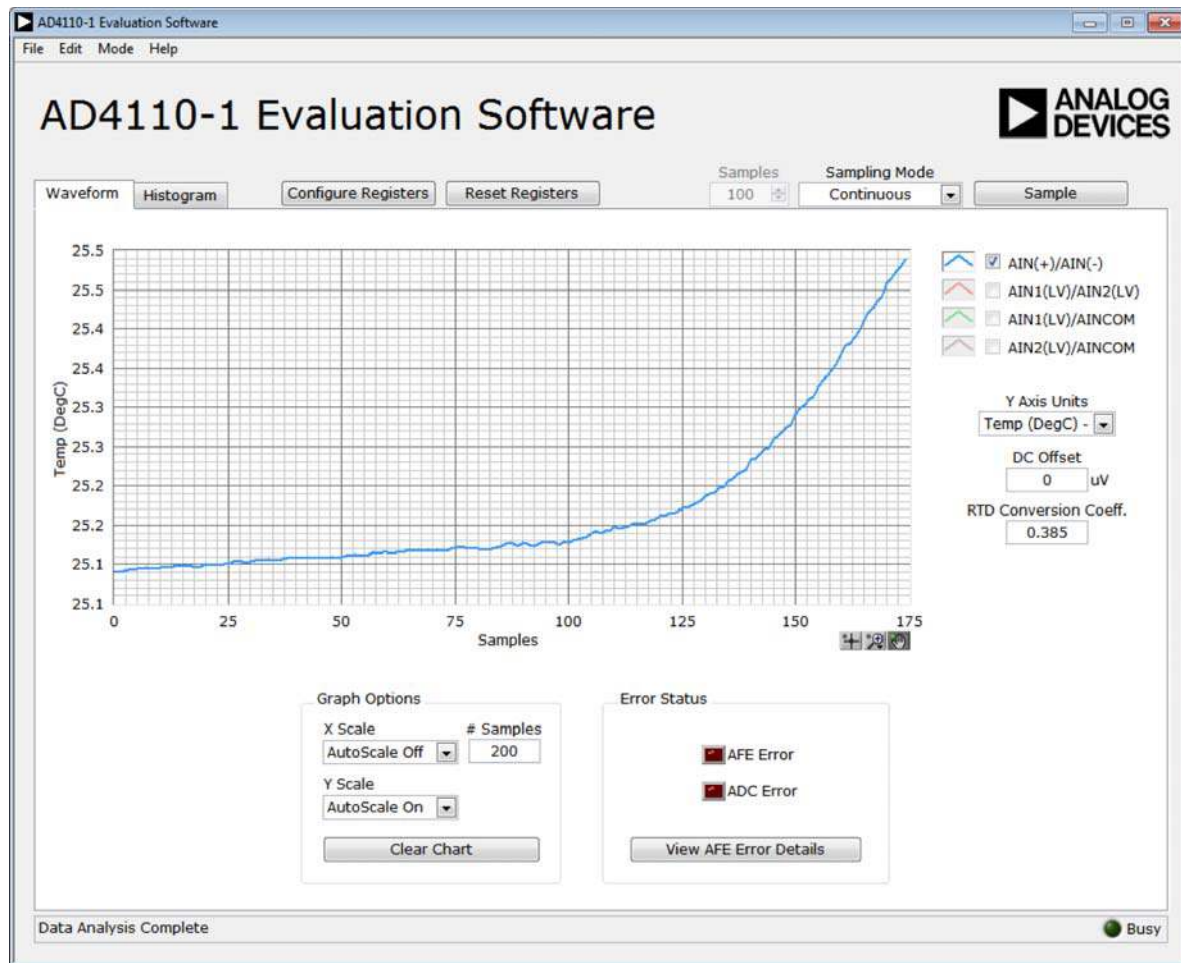

Figure 23. RTD Mode

Y-Axis Units for RTD Mode

When the **RTD Mode** is selected from the **Demo Modes** drop-down menu (see Figure 3), the y-axis units of the waveform display automatically change to temperature (degrees Celsius).

DC Offset for RTD Mode

Any dc offset can be compensated for. The value entered in the **DC Offset** text box is subtracted from the ADC conversion result.

RTD Conversion Coefficient

Depending on the type of RTD sensor connected, the corresponding temperature coefficient is used to calculate the displayed temperature shown in the **RTD Conversion Coeff.** field.

MAIN WINDOW—CURRENT MODE

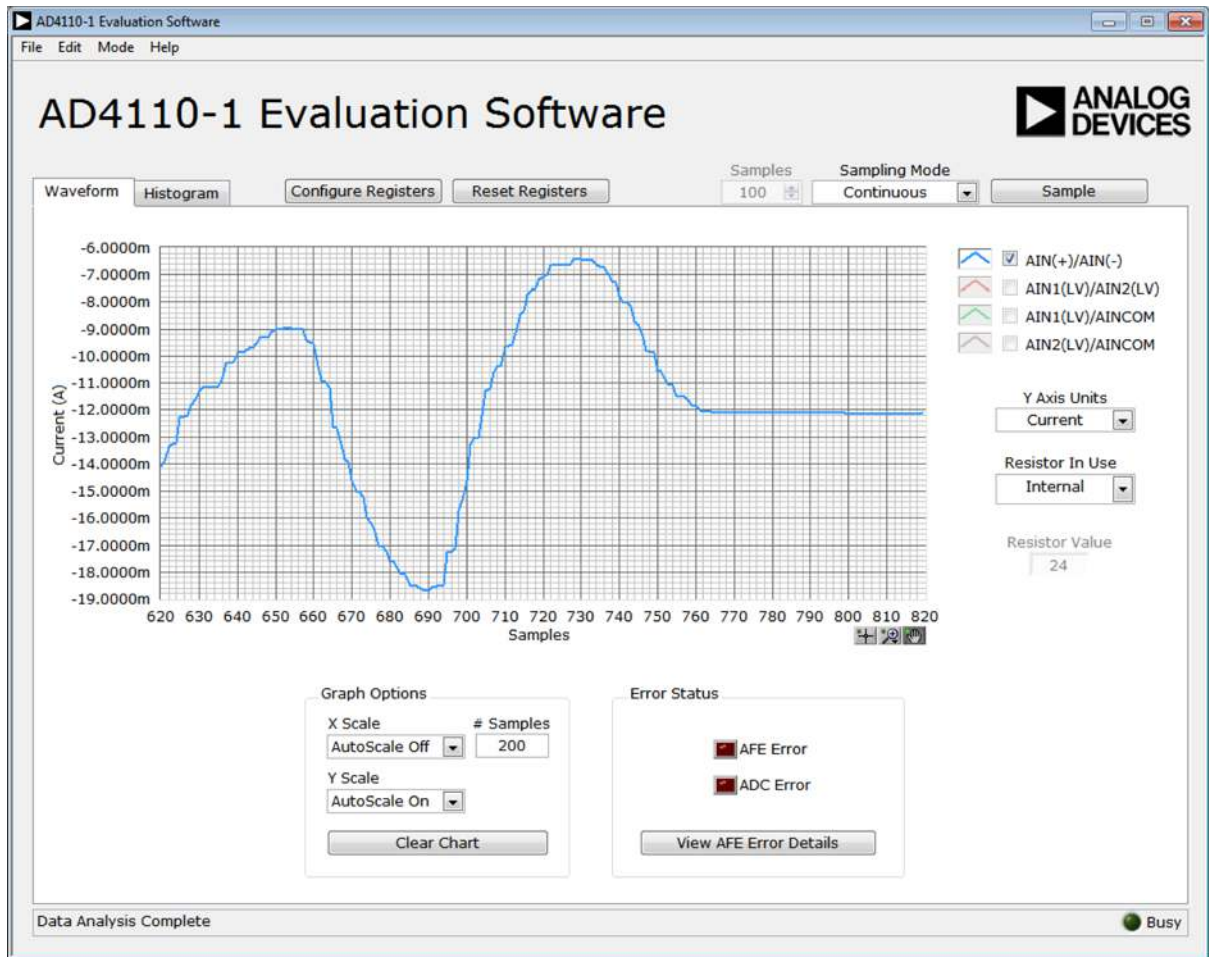

Figure 24. Current Mode

Y-Axis Units for Current Mode

When the **4-20mA Mode** is selected from the **Demo Modes** dropdown menu (see Figure 3) is selected, the y-axis units of the waveform display automatically changes to current displayed as amperes.

Field Power Supply Mode

The **AD4110-1** provides an option to supply power to a current output sensor connected between the AIN(+) and AIN(-) pins up to ± 24 mA.

When the **4-20mA Field Instrument** is selected from the **Demo Modes** dropdown menu (see Figure 3), the VDD and VSS power supplies are connected to the AIN(+) and AIN(-) pins and provide power to the connected sensor.

Resistor In Use Dropdown Menu

The **AD4110-1** allows an internal or external sensing resistor to be used. The user can select this sensing resistor here or in the AFE_CNTRL2 register of the **AD4110-1**.

Resistor Value

When the **Internal Resistor** is selected from the **Resistor In Use** dropdown menu, the **Resistor Value** field displays the resistor value of 24Ω . When the **External Resistor** is selected from the **Resistor In Use** dropdown menu, the user can input the value of the resistor connected in the **Resistor Value** field.

MANUAL CONFIGURATION OF REGISTERS

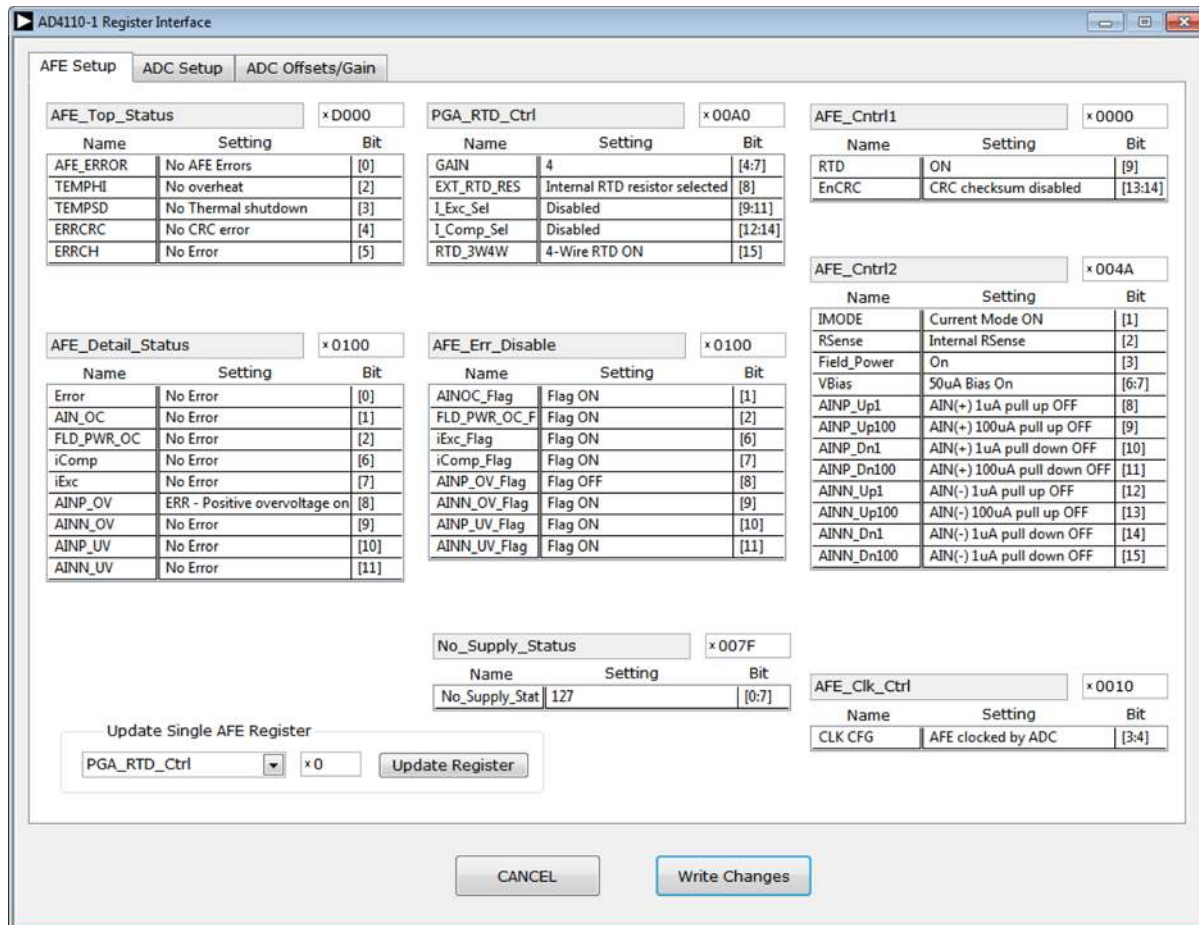

Figure 25. AD4110-1 Register Interface Window

Register Configuration

Figure 25 shows the AD4110-1 Register Interface setup window with the AFE Setup tab selected.

The status of the AFE, ADC, and ADC offset/gain register contents are updated automatically from their respective device registers when the **Configure Registers** window is launched. Select the required tab and manually change the required register settings.

When finished manually configuring the registers, click **Write Changes** to update all device registers and return to the main software analysis window. Click **Cancel** to return to the main software analysis window without writing changes.

Update Single AFE Register Pane

This pane allows the user to write to one register without updating all of the registers. To use this feature, take the following steps:

1. Select the register from dropdown menu.
2. Enter the new register value in hexadecimal format.
3. Click **Update Register**.

Click **Cancel** to close the window without updating any registers.

For full details on register programming options, see the AD4110-1 data sheet. When using the demo modes, the recommended register settings are automatically programmed to the AD4110-1 device (see the Demo Modes section).

Save/Load Configuration

After any register changes are made to the AD4110-1 device and the main window is displayed, the new configuration can be saved to a file for later use.

From the main window menu, click **File**, and then save the register configuration.

DEFAULT MODE OF OPERATION AT POWER-UP

The input pins of the AD4110-1, AIN(+) and AIN(-), can be configured for voltage or current input. The factory default mode of operation for the AD4110-1 is current mode. At power-up, the AD4110-1 accepts an input current and routes it through a low impedance sense resistor for measurement.

The default mode at power-up is also the mode of operation used in a “No Power Mode” condition. The power-up mode for the high voltage channel can be programmed.

From the main window menu, click **Mode** and then select the **No Power Supply Mode** option (see Figure 3). The dialog box in Figure 26 displays.

The dialog box prompts the user to confirm if they want to change the default “No Power Mode” mode of operation to **Current Mode** or **Voltage Mode**.

After a reset, the AD4110-1 defaults to the mode selected.

If the default mode is set to **Current Mode** and a current input is connected to the AD4110-1 inputs, the AD4110-1 maintains the loop current, even when a power supply is not connected.

The number of changes left for the user is indicated by the text field shown in Figure 26.

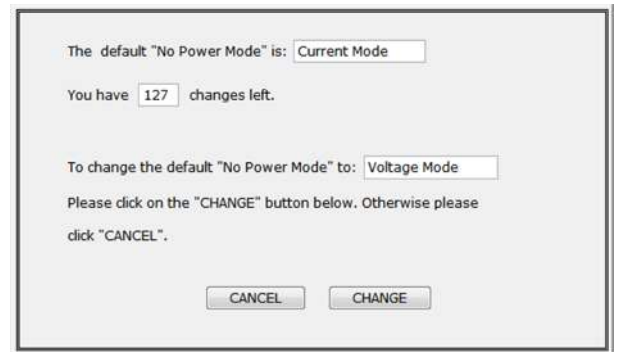

Figure 26. Default Mode Selection Dialog Box



ESD Caution

ESD (electrostatic discharge) sensitive device. Charged devices and circuit boards can discharge without detection. Although this product features patented or proprietary protection circuitry, damage may occur on devices subjected to high energy ESD. Therefore, proper ESD precautions should be taken to avoid performance degradation or loss of functionality.

Legal Terms and Conditions

By using the evaluation board discussed herein (together with any tools, components documentation or support materials, the “Evaluation Board”), you are agreeing to be bound by the terms and conditions set forth below (“Agreement”) unless you have purchased the Evaluation Board, in which case the Analog Devices Standard Terms and Conditions of Sale shall govern. Do not use the Evaluation Board until you have read and agreed to the Agreement. Your use of the Evaluation Board shall signify your acceptance of the Agreement. This Agreement is made by and between you (“Customer”) and Analog Devices, Inc. (“ADI”), with its principal place of business at One Technology Way, Norwood, MA 02062, USA. Subject to the terms and conditions of the Agreement, ADI hereby grants to Customer a free, limited, personal, temporary, non-exclusive, non-sublicensable, non-transferable license to use the Evaluation Board FOR EVALUATION PURPOSES ONLY. Customer understands and agrees that the Evaluation Board is provided for the sole and exclusive purpose referenced above, and agrees not to use the Evaluation Board for any other purpose. Furthermore, the license granted is expressly made subject to the following additional limitations: Customer shall not (i) rent, lease, display, sell, transfer, assign, sublicense, or distribute the Evaluation Board; and (ii) permit any Third Party to access the Evaluation Board. As used herein, the term “Third Party” includes any entity other than ADI, Customer, their employees, affiliates and in-house consultants. The Evaluation Board is NOT sold to Customer; all rights not expressly granted herein, including ownership of the Evaluation Board, are reserved by ADI. CONFIDENTIALITY. This Agreement and the Evaluation Board shall all be considered the confidential and proprietary information of ADI. Customer may not disclose or transfer any portion of the Evaluation Board to any other party for any reason. Upon discontinuation of use of the Evaluation Board or termination of this Agreement, Customer agrees to promptly return the Evaluation Board to ADI. ADDITIONAL RESTRICTIONS. Customer may not disassemble, decompile or reverse engineer chips on the Evaluation Board. Customer shall inform ADI of any occurred damages or any modifications or alterations it makes to the Evaluation Board, including but not limited to soldering or any other activity that affects the material content of the Evaluation Board. Modifications to the Evaluation Board must comply with applicable law, including but not limited to the RoHS Directive. TERMINATION. ADI may terminate this Agreement at any time upon giving written notice to Customer. Customer agrees to return to ADI the Evaluation Board at that time. LIMITATION OF LIABILITY. THE EVALUATION BOARD PROVIDED HEREUNDER IS PROVIDED “AS IS” AND ADI MAKES NO WARRANTIES OR REPRESENTATIONS OF ANY KIND WITH RESPECT TO IT. ADI SPECIFICALLY DISCLAIMS ANY REPRESENTATIONS, ENDORSEMENTS, GUARANTEES, OR WARRANTIES, EXPRESS OR IMPLIED, RELATED TO THE EVALUATION BOARD INCLUDING, BUT NOT LIMITED TO, THE IMPLIED WARRANTY OF MERCHANTABILITY, TITLE, FITNESS FOR A PARTICULAR PURPOSE OR NONINFRINGEMENT OF INTELLECTUAL PROPERTY RIGHTS. IN NO EVENT WILL ADI AND ITS LICENSORS BE LIABLE FOR ANY INCIDENTAL, SPECIAL, INDIRECT, OR CONSEQUENTIAL DAMAGES RESULTING FROM CUSTOMER’S POSSESSION OR USE OF THE EVALUATION BOARD, INCLUDING BUT NOT LIMITED TO LOST PROFITS, DELAY COSTS, LABOR COSTS OR LOSS OF GOODWILL. ADI’S TOTAL LIABILITY FROM ANY AND ALL CAUSES SHALL BE LIMITED TO THE AMOUNT OF ONE HUNDRED US DOLLARS (\$100.00). EXPORT. Customer agrees that it will not directly or indirectly export the Evaluation Board to another country, and that it will comply with all applicable United States federal laws and regulations relating to exports. GOVERNING LAW. This Agreement shall be governed by and construed in accordance with the substantive laws of the Commonwealth of Massachusetts (excluding conflict of law rules). Any legal action regarding this Agreement will be heard in the state or federal courts having jurisdiction in Suffolk County, Massachusetts, and Customer hereby submits to the personal jurisdiction and venue of such courts. The United Nations Convention on Contracts for the International Sale of Goods shall not apply to this Agreement and is expressly disclaimed.