

(b)

NOTES:

- FOR WAVESOLDERING (SOLDER BATH TEMPERATURE 265°C FOR 8 SEC. AND SOLDER PREHEAT 150°C FOR 180 SEC.)
- IP RATING: IP 67
- SEALED TO WITHSTAND PRESSURE UP TO 1,45 PSI FOR 30 MINUTES AFTER HIGH TEMPERATURE EXPOSURE
- METALSHELL: ZINC DIE CAST; min. 50µin NICKEL PLATING over COPPER
- INSULATORS: PBT GF UL 94 V-0, BLACK
- O-RING: SILICONE PER ASTM D2000 70 SHORE A
- SEALING COMPOUND: EPOXY RESIN UL 94 V-0; BLACK
- CONTACTS: COPPER ALLOY PLATING (SEE PART NO):
 PLEASE ADD 1 for 30µin HARD GOLD over min. 50µin NICKEL
 PLEASE ADD 3 for 8µin HARD GOLD over min. 50µin NICKEL
- REAR SPACER CLIPS: COPPER ALLOY; min. 200µin TIN over 80µin NICKEL
PCB-HOLE: $\varnothing 3,1 \pm 0,1$; PCB THICKNESS 1,6mm
- HEXLOCKING SCREWS: STAINLESS STEEL
- PCB-HOLE DRILLINGS and RECOMMENDED PANEL CUT-OUT ON SHEET 2
- RECOMMENDED TORQUE FOR MOUNTING SCREW 35Ncm (3.1 in.LB) / max.67Ncm (6 in.LB)
- CONNECTOR IS PART MARKED: 15-00048 CONEC ABC

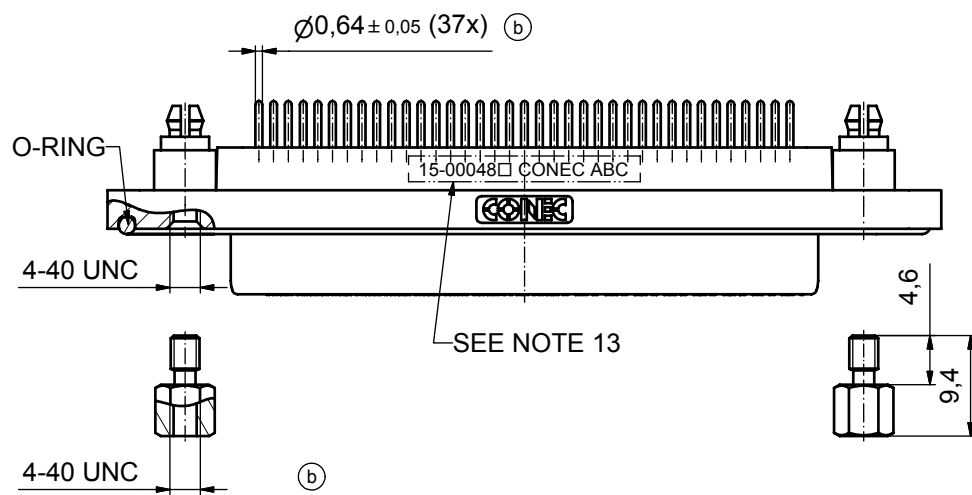
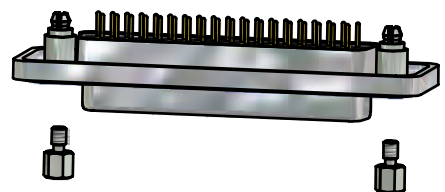
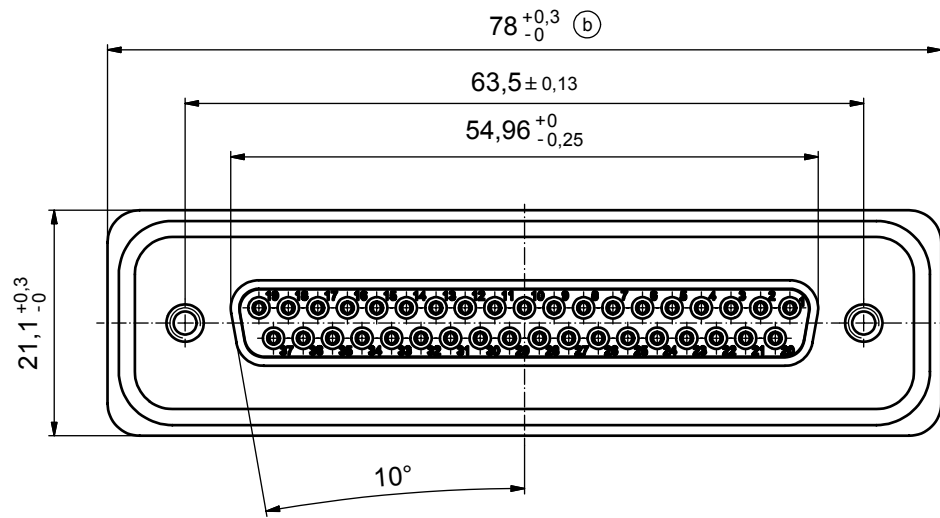
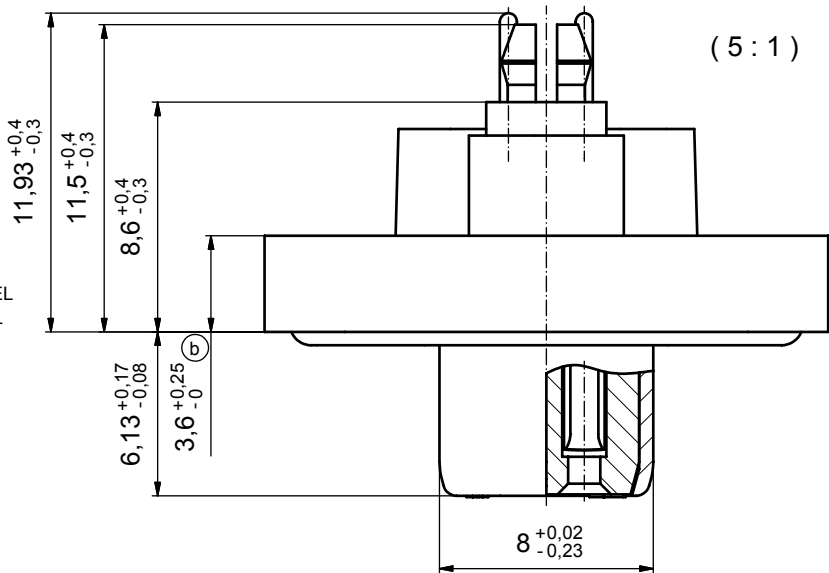

(b) AT ALL TIMES WATER RESISTANT CONNECTORS NOT IN USE SHOULD BE COVERED WITH A CONEC WATER RESISTANT CAP OR WATER TIGHT HOOD.



APPROVAL # FREIGABE # DEBLOCAGE # AUTORIZACION # APPROVAL	
CUSTOMER APPROVAL DATE:	
NAME:	TITLE:
COMPANY NAME:	
APPROVAL # FREIGABE # DEBLOCAGE # AUTORIZACION # APPROVAL	

THIS DRAWING MAY NOT BE COPIED OR REPRODUCED IN ANY WAY, AND MAY NOT BE PASSED ON TO A THIRD PARTY WITHOUT WRITTEN PERMISSION. OWNERSHIP AND COPYRIGHT OF CONEC GmbH				tolerance		dim. in mm	scale: 2:1 (5:1)	
DO NOT ALTER CAD DRAWING BY HAND				date			material: see notes	
5 x b	A3435	23.09.09	HS	drawn	17.10.08	Petker	title: D-SUB FEMALE 37pos. SOLDER PIN STRAIGHT with rear spacer clip and hexlocking screw	
a	Origin			appd.	21.10.08	Fischer		
rev.	description	date	name	norm				
CONEC®				d-old			dwg no: Inventor 10	DIN-A3
								sh: 1
								part no: 15-00048 (see note 8)

title: D-SUB FEMALE 37pos. SOLDER PIN STRAIGHT with rear spacer clip and hexlocking screw	
dwg no: Inventor 10	DIN-A3
sh: 1	
part no: 15-00048 (see note 8)	

