



MICROCHIP

MGC3130
Hillstar Development Kit
User's Guide

Note the following details of the code protection feature on Microchip devices:

- Microchip products meet the specification contained in their particular Microchip Data Sheet.
- Microchip believes that its family of products is one of the most secure families of its kind on the market today, when used in the intended manner and under normal conditions.
- There are dishonest and possibly illegal methods used to breach the code protection feature. All of these methods, to our knowledge, require using the Microchip products in a manner outside the operating specifications contained in Microchip's Data Sheets. Most likely, the person doing so is engaged in theft of intellectual property.
- Microchip is willing to work with the customer who is concerned about the integrity of their code.
- Neither Microchip nor any other semiconductor manufacturer can guarantee the security of their code. Code protection does not mean that we are guaranteeing the product as "unbreakable."

Code protection is constantly evolving. We at Microchip are committed to continuously improving the code protection features of our products. Attempts to break Microchip's code protection feature may be a violation of the Digital Millennium Copyright Act. If such acts allow unauthorized access to your software or other copyrighted work, you may have a right to sue for relief under that Act.

Information contained in this publication regarding device applications and the like is provided only for your convenience and may be superseded by updates. It is your responsibility to ensure that your application meets with your specifications. MICROCHIP MAKES NO REPRESENTATIONS OR WARRANTIES OF ANY KIND WHETHER EXPRESS OR IMPLIED, WRITTEN OR ORAL, STATUTORY OR OTHERWISE, RELATED TO THE INFORMATION, INCLUDING BUT NOT LIMITED TO ITS CONDITION, QUALITY, PERFORMANCE, MERCHANTABILITY OR FITNESS FOR PURPOSE. Microchip disclaims all liability arising from this information and its use. Use of Microchip devices in life support and/or safety applications is entirely at the buyer's risk, and the buyer agrees to defend, indemnify and hold harmless Microchip from any and all damages, claims, suits, or expenses resulting from such use. No licenses are conveyed, implicitly or otherwise, under any Microchip intellectual property rights unless otherwise stated.

Trademarks

The Microchip name and logo, the Microchip logo, dsPIC, FlashFlex, flexPWR, JukeBlox, KEELOQ, KEELOQ logo, Klear, LANCheck, MediaLB, MOST, MOST logo, MPLAB, OptoLyzer, PIC, PICSTART, PIC³² logo, RightTouch, SpyNIC, SST, SST Logo, SuperFlash and UNI/O are registered trademarks of Microchip Technology Incorporated in the U.S.A. and other countries.

The Embedded Control Solutions Company and mTouch are registered trademarks of Microchip Technology Incorporated in the U.S.A.

Analog-for-the-Digital Age, BodyCom, chipKIT, chipKIT logo, CodeGuard, dsPICDEM, dsPICDEM.net, ECAN, In-Circuit Serial Programming, ICSP, Inter-Chip Connectivity, KlearNet, KlearNet logo, MiWi, motorBench, MPASM, MPF, MPLAB Certified logo, MPLIB, MPLINK, MultiTRAK, NetDetach, Omniscient Code Generation, PICDEM, PICDEM.net, PICkit, PICtail, RightTouch logo, REAL ICE, SQI, Serial Quad I/O, Total Endurance, TSHARC, USBCheck, VariSense, ViewSpan, WiperLock, Wireless DNA, and ZENA are trademarks of Microchip Technology Incorporated in the U.S.A. and other countries.

SQTP is a service mark of Microchip Technology Incorporated in the U.S.A.

Silicon Storage Technology is a registered trademark of Microchip Technology Inc. in other countries.

GestIC is a registered trademark of Microchip Technology Germany II GmbH & Co. KG, a subsidiary of Microchip Technology Inc., in other countries.

All other trademarks mentioned herein are property of their respective companies.

© 2013-2016, Microchip Technology Incorporated, Printed in the U.S.A., All Rights Reserved.

ISBN: 978-1-5224-0206-0

QUALITY MANAGEMENT SYSTEM
CERTIFIED BY DNV
== ISO/TS 16949 ==

Microchip received ISO/TS-16949:2009 certification for its worldwide headquarters, design and wafer fabrication facilities in Chandler and Tempe, Arizona; Gresham, Oregon and design centers in California and India. The Company's quality system processes and procedures are for its PIC[®] MCUs and dsPIC[®] DSCs, KEELOQ[®] code hopping devices, Serial EEPROMs, microperipherals, nonvolatile memory and analog products. In addition, Microchip's quality system for the design and manufacture of development systems is ISO 9001:2000 certified.

Object of Declaration: MGC3130 Hillstar Development Kit User's Guide

EU Declaration of Conformity

This declaration of conformity is issued by the manufacturer.

The development/evaluation tool is designed to be used for research and development in a laboratory environment. This development/evaluation tool is not a Finished Appliance, nor is it intended for incorporation into Finished Appliances that are made commercially available as single functional units to end users under EU EMC Directive 2004/108/EC and as supported by the European Commission's Guide for the EMC Directive 2004/108/EC (8th February 2010).

This development/evaluation tool complies with EU RoHS2 Directive 2011/65/EU.

For information regarding the exclusive, limited warranties applicable to Microchip products, please see Microchip's standard terms and conditions of sale, which are printed on our sales documentation and available at www.microchip.com.

Signed for and on behalf of Microchip Technology Inc. at Chandler, Arizona, USA

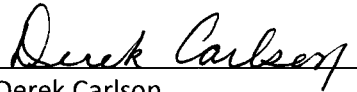

Derek Carlson
VP Development Tools

16-July-2013
Date

MGC3130 Hillstar Development Kit User's Guide

NOTES:

Table of Contents

Preface	7
Introduction.....	7
Document Layout	7
Conventions Used in this Guide	8
Warranty Registration.....	9
Recommended Reading.....	9
The Microchip Website.....	10
Development Systems Customer Change Notification Service	10
Customer Support	11
Revision History	11
 Chapter 1. Overview	
1.1 Introduction	13
1.2 Hillstar Concept and Deliverables	13
1.3 Hillstar Development Kit Package Content	14
1.4 Hillstar Development Kit Reference Electrodes	15
1.5 MGC3130 Software Package – Aurea GUI and GestIC Library	17
1.6 MGC3130 Software Development Kit (SDK)	17
 Chapter 2. Getting Started	
2.1 Prerequisites	19
2.2 Step 1: Build-up Development Kit	19
2.3 Step 2: Connecting Hillstar Development Kit with Your PC	20
2.4 Step 3: Install Windows CDC Driver	20
2.5 Step 4: Start Aurea	20
 Chapter 3. Hillstar Boards – Hardware Description	
3.1 Overview	23
3.1.1 I ² C to USB Bridge	23
3.1.2 MGC3130 Unit	23
3.1.3 95x60 mm Reference Electrode PCB	24
3.2 MGC3130 Unit	24
3.3 Hillstar 95x60 mm Reference Electrode	25
3.4 I ² C to USB Bridge	27
 Chapter 4. Design In: Hillstar In Target Application	
4.1 Introduction	31
4.2 Integration Examples	31
 Chapter 5. Troubleshooting	

MGC3130 Hillstar Development Kit User's Guide

Appendix A. Schematics

A.1 Introduction	37
A.2 Bill of Materials	37
A.3 Board – Schematics and Layout	39

Appendix B. Sensitivity Profile and Capacitances

B.1 Introduction	43
B.2 Sensitivity Profiles	43
B.3 Electrode Capacities	44

Appendix C. Parameterization Support

C.1 How to Build a Hand Brick	45
C.2 Usage of the Hand Brick as Artificial Hand	47

Appendix D. Driver Installation Manual

D.1 Open Device Manager	49
D.2 Select Device	49
D.3 Locate Driver	50
D.4 Verify Communication	50

Appendix E. Glossary

Worldwide Sales and Service	53
-----------------------------------	----



MGC3130 HILLSTAR DEVELOPMENT KIT USER'S GUIDE

Preface

NOTICE TO CUSTOMERS

All documentation becomes dated, and this manual is no exception. Microchip tools and documentation are constantly evolving to meet customer needs, so some actual dialogs and/or tool descriptions may differ from those in this document. Please refer to our website (www.microchip.com) to obtain the latest documentation available.

Documents are identified with a “DS” number. This number is located on the bottom of each page, in front of the page number. The numbering convention for the DS number is “DSXXXXA”, where “XXXX” is the document number and “A” is the revision level of the document.

For the most up-to-date information on development tools, see the MPLAB® IDE online help. Select the Help menu, and then Topics to open a list of available online help files.

INTRODUCTION

This chapter contains general information that will be useful to know before using the MGC3130 Hillstar Development Kit. Items discussed in this chapter include:

- Document Layout
- Conventions Used in this Guide
- Warranty Registration
- Recommended Reading
- The Microchip website
- Development Systems Customer Change Notification Service
- Customer Support
- Revision History

DOCUMENT LAYOUT

This document describes the installation and use of the MGC3130 Hillstar Development Kit. The document is organized as follows:

- **Chapter 1. “Overview”**
- **Chapter 2. “Getting Started”**
- **Chapter 3. “Hillstar Boards – Hardware Description”**
- **Chapter 4. “Design In: Hillstar In Target Application”**
- **Chapter 5. “Troubleshooting”**
- **Appendix A. “Schematics”**
- **Appendix B. “Sensitivity Profile and Capacitances”**
- **Appendix C. “Parameterization Support”**
- **Appendix D. “Driver Installation Manual”**
- **Appendix E. “Glossary”**

MGC3130 Hillstar Development Kit User's Guide

CONVENTIONS USED IN THIS GUIDE

This manual uses the following documentation conventions:

DOCUMENTATION CONVENTIONS

Description	Represents	Examples
Arial font:		
Italic characters	Referenced books	<i>MPLAB[®] IDE User's Guide</i>
	Emphasized text	...is the <i>only</i> compiler...
Initial caps	A window	the Output window
	A dialog	the Settings dialog
	A menu selection	select Enable Programmer
Quotes	A field name in a window or dialog	"Save project before build"
Underlined, italic text with right angle bracket	A menu path	<u><i>File>Save</i></u>
Bold characters	A dialog button	Click OK
	A tab	Click the Power tab
N'Rnnnn	A number in verilog format, where N is the total number of digits, R is the radix and n is a digit.	4'b0010, 2'hF1
Text in angle brackets < >	A key on the keyboard	Press <Enter>, <F1>
Courier New font:		
Plain Courier New	Sample source code	#define START
	Filenames	autoexec.bat
	File paths	c:\mcc18\h
	Keywords	_asm, _endasm, static
	Command-line options	-Opa+, -Opa-
	Bit values	0, 1
	Constants	0xFF, 'A'
Italic Courier New	A variable argument	<i>file.o</i> , where <i>file</i> can be any valid filename
Square brackets []	Optional arguments	mcc18 [options] <i>file</i> [options]
Curly brackets and pipe character: { }	Choice of mutually exclusive arguments; an OR selection	errorlevel {0 1}
Ellipses...	Replaces repeated text	var_name [, var_name...]
	Represents code supplied by user	void main (void) { ... }

WARRANTY REGISTRATION

Please complete the enclosed Warranty Registration Card and mail it promptly. Sending in the Warranty Registration Card entitles users to receive new product updates. Interim software releases are available at the Microchip website.

RECOMMENDED READING

This user's guide describes how to use the MGC3130 Hillstar Development Kit. Other useful documents are listed below. The following Microchip documents are available and recommended as supplemental reference resources.

GestIC[®] Design Guide: Electrodes and System Design (DS40001716)

This document describes the MGC3130 system characteristic parameters and the design process. It enables the user to generate a good electrode design and to parameterize the full GestIC system.

MGC3030/MGC3130 GestIC[®] Library Interface Description (DS40001718)

This document is the interface description of the MGC3130's GestIC Library. It outlines the function of the Library's message interface, and contains the complete message reference to control and operate the MGC3130 system.

MGC3030/MGC3130 3D Gesture Controller Data Sheet (DS40001667)

Consult this document for information regarding the MGC3130 3D Tracking and Gesture Controller.

Aurea Graphical User Interface User's Guides (DS40001681)

This document describes how to use the MGC3130 Aurea Graphical User Interface.

MGC3130 Hillstar Development Kit User's Guide

THE MICROCHIP WEBSITE

Microchip provides online support via our website at www.microchip.com. This website is used as a means to make files and information easily available to customers. Accessible by using your favorite Internet browser, the website contains the following information:

- **Product Support** – Data sheets and errata, application notes and sample programs, design resources, user's guides and hardware support documents, latest software releases and archived software
- **General Technical Support** – Frequently Asked Questions (FAQs), technical support requests, online discussion groups, Microchip consultant program member listing
- **Business of Microchip** – Product selector and ordering guides, latest Microchip press releases, listing of seminars and events, listings of Microchip sales offices, distributors and factory representatives™

DEVELOPMENT SYSTEMS CUSTOMER CHANGE NOTIFICATION SERVICE

Microchip's customer notification service helps keep customers current on Microchip products. Subscribers will receive e-mail notification whenever there are changes, updates, revisions or errata related to a specified product family or development tool of interest.

To register, access the Microchip website at www.microchip.com, click on Customer Change Notification and follow the registration instructions.

The Development Systems product group categories are:

- **Compilers** – The latest information on Microchip C compilers, assemblers, linkers and other language tools. These include all MPLAB® C compilers; all MPLAB assemblers (including MPASM™ assembler); all MPLAB linkers (including MPLINK™ object linker); and all MPLAB librarians (including MPLIB™ object librarian).
- **Emulators** – The latest information on Microchip in-circuit emulators. This includes the MPLAB REAL ICE™ and MPLAB ICE 2000 in-circuit emulators.
- **In-Circuit Debuggers** – The latest information on the Microchip in-circuit debuggers. This includes MPLAB ICD 3 in-circuit debuggers and PICKit™ 3 debug express.
- **MPLAB® IDE** – The latest information on Microchip MPLAB IDE, the Windows® Integrated Development Environment for development systems tools. This list is focused on the MPLAB IDE, MPLAB IDE Project Manager, MPLAB Editor and MPLAB SIM simulator, as well as general editing and debugging features.
- **Programmers** – The latest information on Microchip programmers. These include production programmers such as MPLAB REAL ICE in-circuit emulator, MPLAB ICD 3 in-circuit debugger and MPLAB PM3 device programmers. Also included are nonproduction development programmers such as PICSTART® Plus and PICKit 2 and 3.

CUSTOMER SUPPORT

Users of Microchip products can receive assistance through several channels:

- Distributor or Representative
- Local Sales Office
- Field Application Engineer (FAE)
- Technical Support

Customers should contact their distributor, representative or field application engineer (FAE) for support. Local sales offices are also available to help customers. A listing of sales offices and locations is included in the back of this document.

Technical support is available through the website at:

<http://www.microchip.com/support>.

REVISION HISTORY

Revision A (October, 2013)

This is the initial release of the document.

Revision B (January, 2016)

Updated Recommended Reading section; Updated Figures 2-1, 3-2, 3-6, A-2, A-3 and A-4.

MGC3130 Hillstar Development Kit User's Guide

NOTES:

Chapter 1. Overview

1.1 INTRODUCTION

The MGC3130 is a 3G gesture controller based on Microchip's GestIC[®] technology. It is developed as a mixed-signal controller. The MGC3130 has one transmit and five very sensitive receive channels that are capable to detect changes of a transmitted electrical field (E-field) corresponding to capacitive changes in the femtofarad ($1 \text{ fF} = 10^{-15}\text{F}$) range.

In order to transmit and receive an electrical field, electrodes have to be connected to the transmitting and receiving channels of the MGC3130 controller. The spatial arrangement of the electrodes allows the chip to determine the center of gravity of the electric field distortion, and thus position tracking and gesture recognition of a user's hand in the detection space.

1.2 HILLSTAR CONCEPT AND DELIVERABLES

The Hillstar Development Kit is designed to support an easy integration of Microchip's MGC3130 3D Gesture and Tracking Controller into customer's applications. It provides MGC3130 system setup, related hardware and software references.

With the MGC3130 Software Package, including Aurea Graphical User Interface and GestIC Library, the MGC3130 Software Development Kit (SDK) and PIC18 Host Reference code, design-in is easy in five steps:

1. Feature Definition
2. Electrode Design
3. MGC3130 Parameterization
4. Host Application Programming
5. Verification

Hillstar hardware builds a complete MGC3130 reference system consisting of three individual PCBs:

- MGC3130 Unit
- I²C to USB Bridge
- Reference Electrode with a 95x60 mm sensitive area

It can be plugged to a PC via USB cable and used for evaluation of MGC3130 chip and GestIC technology. During the customer's design-in process the individual boards can be combined according to the customers need.

Three examples are given below:

- Combine MGC3130 Unit and I²C to USB Bridge to evaluate customized electrodes
- Use I²C to USB Bridge to parameterize and debug the MGC3130 application circuitry in the customer's design
- Combine MGC3130 Unit and Electrodes to develop gesture-driven applications for PC-based or embedded software environments

MGC3130 Hillstar Development Kit User's Guide

The Hillstar Development Kit provides an artificial test hand, further called hand brick, helping to stimulate the human hand operating the GestIC application. The hand brick has to be used during the design-in process to parametrize and evaluate customer's applications. The hand brick's surface is conductive and connected to GND via cable in order to reproduce the grounding conditions of the human body.

1.3 HILLSTAR DEVELOPMENT KIT PACKAGE CONTENT

The Hillstar Development Kit package content is listed below:

- MGC3130 Module
- I²C to USB Bridge Module
- 4-layer reference electrode (95x60 mm sensitive area)
- 'Hand brick' set (self-assembly, four foam blocks, one copper foil)
- USB Cable for PC connection

FIGURE 1-1: HILLSTAR DEVELOPMENT KIT



The 'hand brick' set is used during the design-in process for sensor calibration and performance evaluation purposes. For usage and assembly information, refer to [Appendix C. "Parameterization Support"](#).

1.4 HILLSTAR DEVELOPMENT KIT REFERENCE ELECTRODES

The Hillstar Development Kit includes a collection of layout references (Gerber files) for electrode designs and ready-to-use sensor modules with MGC3130 backside assembly.

The following electrode designs are included:

- **140x90 mm sensitive area** – outline 168 x 119 mm
- **95x60 mm sensitive area** – outline of 120 x 85 mm
- **80x80 mm sensitive area** – outline 104 x 104 mm
- **100x50 mm sensitive area** – outline 128 x 72 mm
- **50x30 mm sensitive area** – outline 63 x 47 mm
- **30x30 mm sensitive area** – outline 49 x 49 mm

Sensor Modules

- **95x60 mm sensitive area** – outline of 120 x 85 mm
- **30x30 mm sensitive area** – outline 49 x 52 mm

FIGURE 1-2: HILLSTAR DEVELOPMENT KIT REFERENCE ELECTRODES

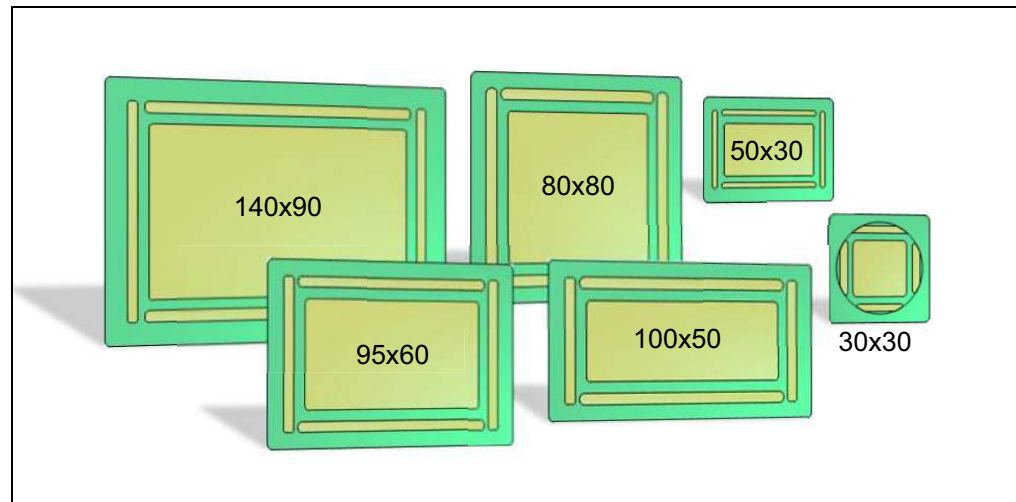

MGC3130 Hillstar Development Kit User's Guide

Dimensions of the designs are given in Table 1-1 and Figure 1-3 below.

TABLE 1-1: ELECTRODE DIMENSIONS

Sensitive Area	140x90 mm	95x60 mm ⁽¹⁾	80x80 mm	100x50 mm	50x30 mm	30x30 mm ⁽²⁾
Version	1.0	1.0	1.0	1.0	1.0	1.0
Layer	2	2	2	2	2	2
Aspect Ratio	approx. 3:2	approx. 3:2	1:1	approx. 2:1	5:3	1:1
A	168 mm	120 mm	104 mm	128 mm	63 mm	49 mm
B	119 mm	85 mm	104 mm	72 mm	47 mm	49 mm
C	138 mm	95,7 mm	79.8 mm	103,6 mm	50 mm	31.8 mm
D	88,7 mm	60,5 mm	79.8 mm	46,8 mm	30 mm	27,3 mm
E	131,7 mm	91,7 mm	75,8 mm	99,6 mm	46 mm	27,3 mm
F	5 mm	5 mm	5 mm	5 mm	2,5 mm	3,5 mm
G	128 mm	85,7 mm	69,8 mm	93,6 mm	44 mm	25,8 mm
H	78,7 mm	50, 5 mm	69, 8 mm	36, 8 mm	24 mm	25,8 mm
Center Electrode cross-hatching	3%	3%	5%	5%	5%	5%
Tx Electrode cross-hatching	50 %	50%	50%	50 %	50 %	50 %
-under center electrode	20 %	20%	20%	20 %	20 %	20 %
-outside center electrode						

Note 1: These dimensions are also valid for 95x60 mm sensor module.

2: These dimensions are also valid for 30x30 mm sensor module except the B dimension which is equal to 52 and Tx electrode which is solid instead of cross-hatched.

FIGURE 1-3: ELECTRODE DIMENSIONS

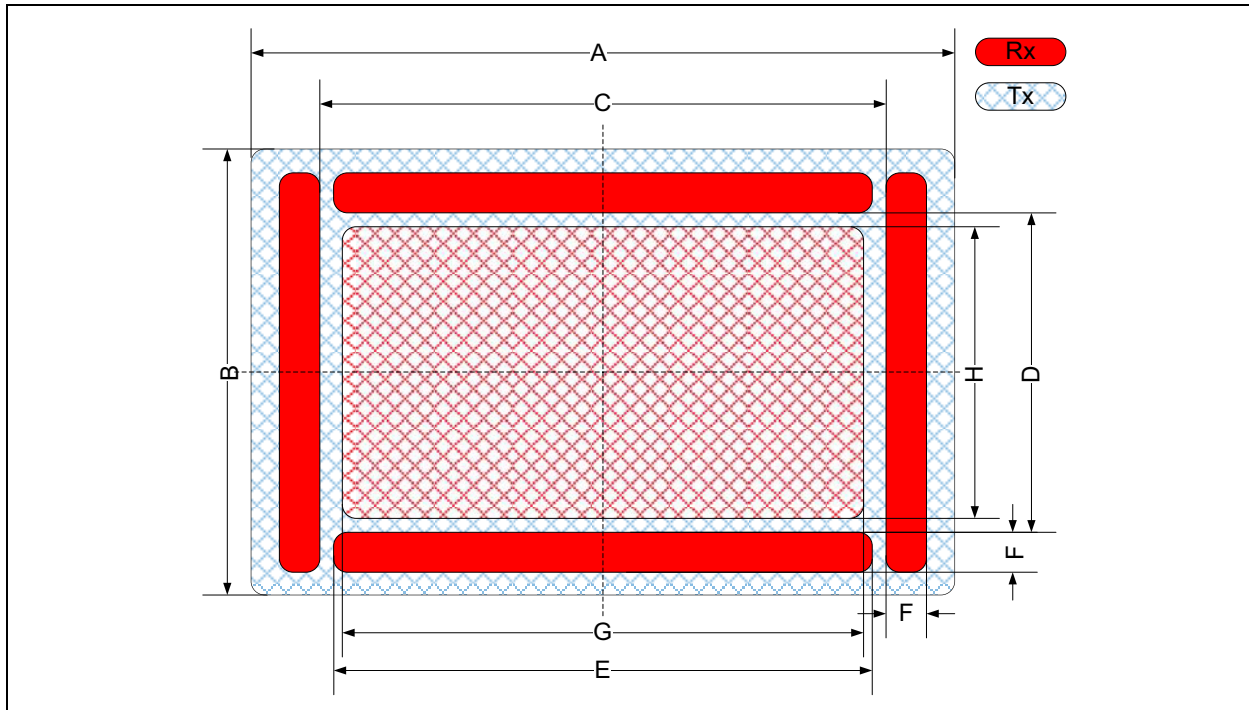

The Gerber data of all electrode reference designs are included in the MGC3130 Hillstar Hardware Reference package and can be downloaded from Microchip's website www.microchip.com/GestICGettingStarted.

1.5 MGC3130 SOFTWARE PACKAGE – AUREA GUI AND GestIC LIBRARY

The MGC3130 Software Package contains all relevant system software and documentation. Hillstar Development Kit is supported by MGC3130 Software Package 0.4 and following versions.

The package contains:

- Aurea PC software
- GestIC Library binary file
- GestIC Parameterization files
- Windows CDC driver
- Documentation

The latest MGC3130 software package can be downloaded from Microchip's website www.microchip.com/GestICGettingStarted.

1.6 MGC3130 SOFTWARE DEVELOPMENT KIT (SDK)

The MGC3130 Software Development Kit (SDK) supports the integration of MGC3130 into a software environment. Thus, it includes a C reference code for GestIC API, a precompiled library for Windows operating systems and a demo application using the GestIC API interface.

Hillstar Development Kit is supported by MGC3130 SDK 0.4 and the following versions.

The latest SDK can be downloaded from Microchip's website www.microchip.com/GestICGettingStarted.

MGC3130 Hillstar Development Kit User's Guide

NOTES:

Chapter 2. Getting Started

Hillstar Development Kit can be used as a stand-alone GestIC system and evaluated in conjunction with the Aurea PC software. This section describes how to get started.

2.1 PREREQUISITES

The following prerequisites have to be fulfilled:

- PC with Windows 7 or Windows 8 operating system and USB port and minimum screen resolution of 1024x768
- Hillstar Development Kit (MGC3130 Unit, I²C to USB Bridge, 95x60 mm frame electrode)
- MGC3130 Software Package 0.4 and following versions

The MGC3130 Software Package is available as a .zip file. Unzip the file, run `setup.exe` and install the package to your PC. The folder structure is as shown in Figure 2-1.

FIGURE 2-1: FOLDER STRUCTURE



2.2 STEP 1: BUILD-UP DEVELOPMENT KIT

Connect Electrodes, MGC3130 Unit and I²C to USB Bridge as shown in Figure 2-2.

Note: Make sure the MGC3130 Unit and the I²C USB Bridge are already connected before plugging in the USB connection.

MGC3130 Hillstar Development Kit User's Guide

FIGURE 2-2: HILLSTAR DEVELOPMENT KIT ASSEMBLING

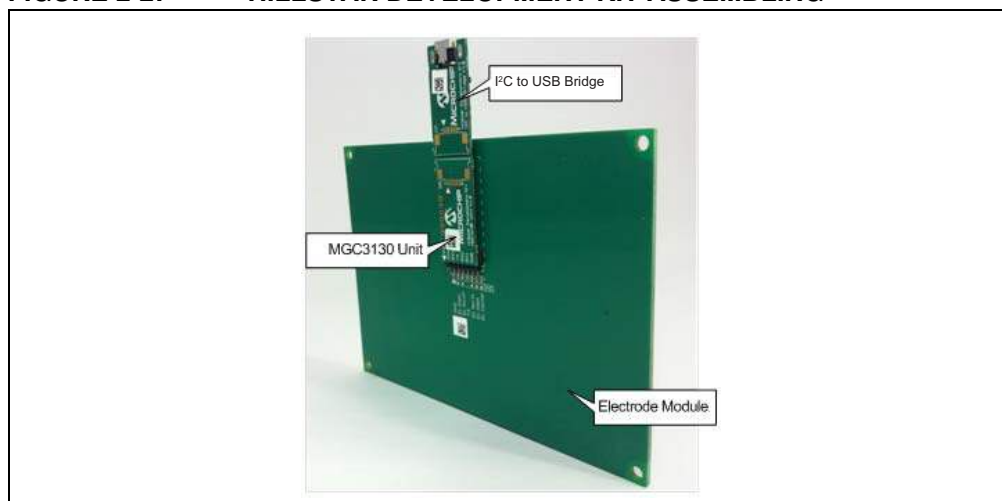

2.3 STEP 2: CONNECTING HILLSTAR DEVELOPMENT KIT WITH YOUR PC

Use the supplied USB cable to connect the Hillstar Development Kit to your PC. The Power LEDs on both, I²C to USB Bridge and MGC3130 Unit will illuminate. Furthermore, LED 1 on the I²C to USB Bridge will flash very fast (~10 Hz). In case LED 1 is flashing slow (~1 Hz), the Windows CDC driver is already installed on your PC. Please skip the next step and go to [Section 2.5 “Step 4: Start Aurea”](#).

2.4 STEP 3: INSTALL WINDOWS CDC DRIVER

The Windows CDC driver can be found in the MGC3130 Software Package in folder `04_Driver`.

When the Hillstar Development Kit is connected to your PC for the first time, Windows requests the appropriate device driver and guides you through the installation process. Alternatively, you can install the driver manually, (e.g., using the device manager). An example for Windows 7 is given in [Appendix D. “Driver Installation Manual”](#).

2.5 STEP 4: START AUREA

Aurea Graphical User Interface, shown in Figure 2-3, is included in the MGC3130 Software Package in the folder `02_GUI`.

Open `Aurea.exe`. Aurea detects the connected device automatically and is ready for use.

FIGURE 2-3: AUREA GRAPHICAL USER INTERFACE

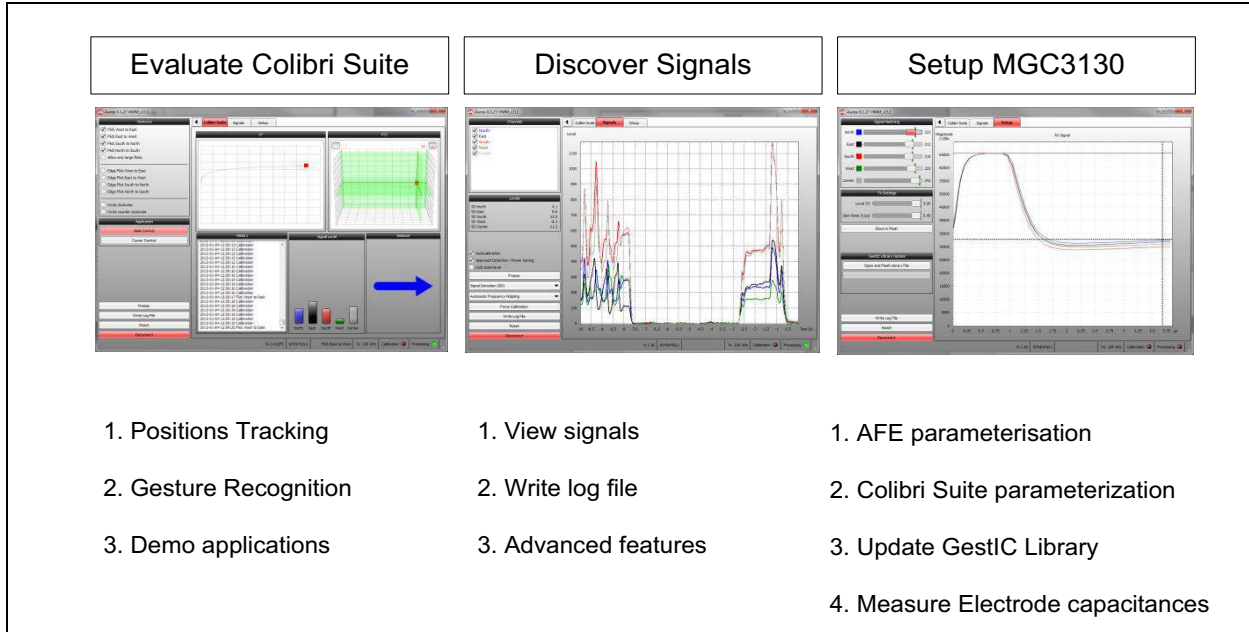

MGC3130 Hillstar Development Kit User's Guide

NOTES:

Chapter 3. Hillstar Boards – Hardware Description

3.1 OVERVIEW

The Hillstar key components are listed below and highlighted in Figure 3-1.

FIGURE 3-1: HILLSTAR DEVELOPMENT KIT OVERVIEW

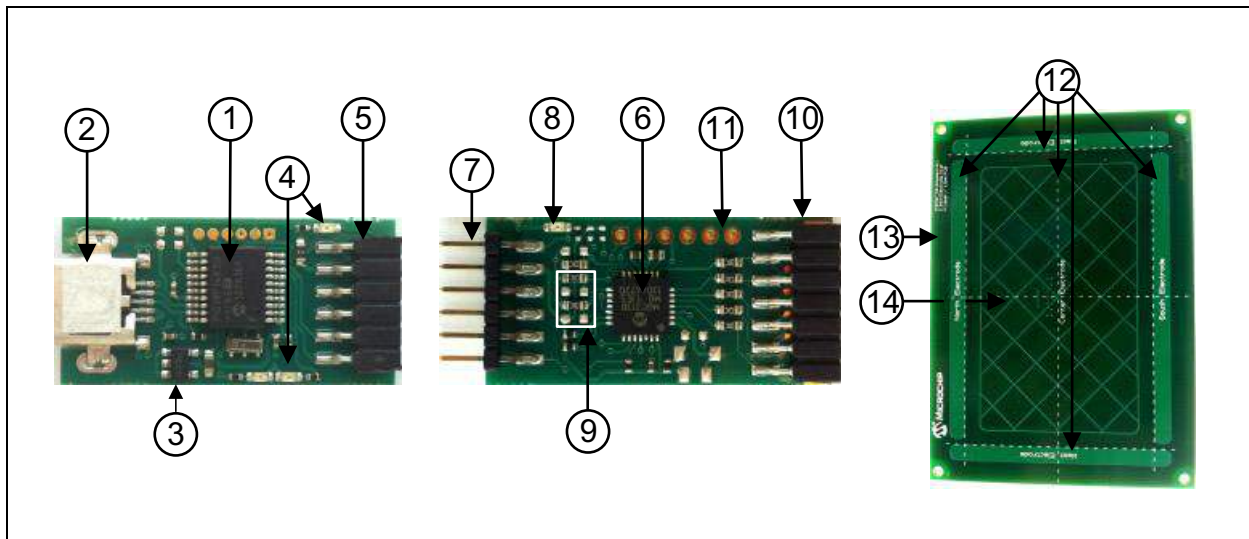

3.1.1 I²C to USB Bridge

1. PIC18F14K50 USB microcontroller
2. Micro-USB connector
3. MCP1801T LDO voltage regulator (converts 5V USB to 3.3 V board supply)
4. Status LEDs (power, communication status)
5. Data interface: 6-pin socket for data communication and power supply

3.1.2 MGC3130 Unit

6. MGC3130 3D Tracking and Gesture Controller
7. Data interface: 6-pin header for data communication and power supply
8. Status LED (power)
9. Interface select
10. Electrode interface: 7-pin socket
11. GesturePort interface (pads for 5 EIOs, 1 GND)

MGC3130 Hillstar Development Kit User's Guide

3.1.3 95x60 mm Reference Electrode PCB

12. Receive electrodes
13. Acrylic cover glass (120 x 85 x 2 mm)
14. Electrode interface: 7-pin header (mounted on backside)

The Gerber data of all Hillstar Development Kit components are included in the MGC3130 Hillstar Hardware Reference package and can be downloaded from Microchip's website www.microchip.com/GestICGettingStarting.

3.2 MGC3130 UNIT

The key element of the MGC3130 Unit is Microchip's MGC3130 3D Tracking and Gesture Controller. The layout print of the unit is shown in Figure 3-2.

FIGURE 3-2: MGC3130 UNIT

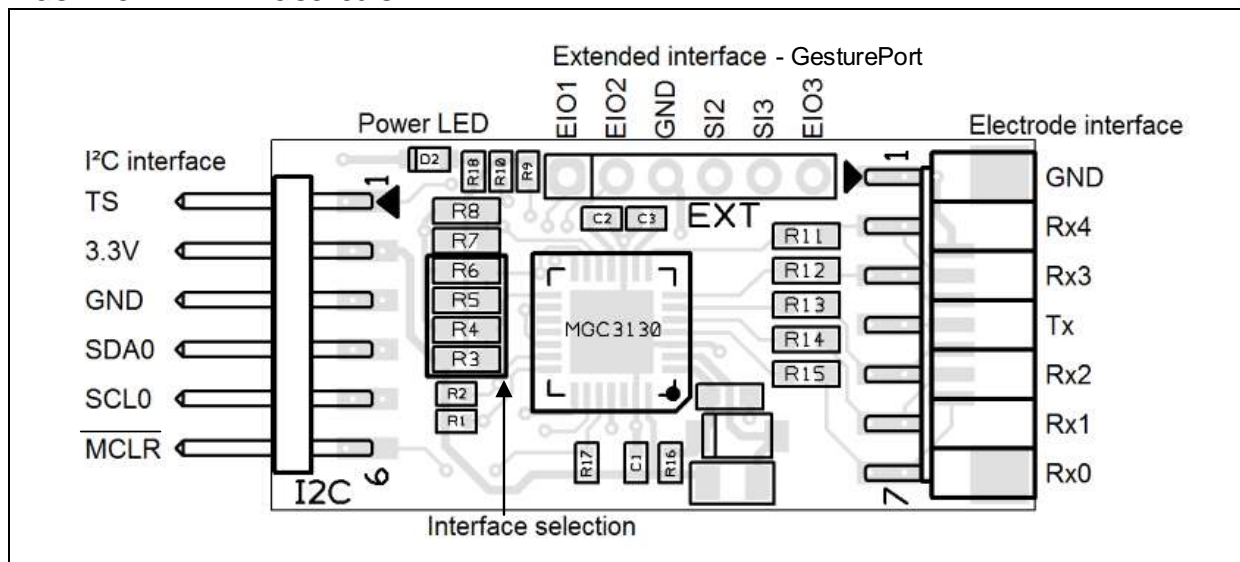

The unit provides a 2 mm 7-pin board-to-board connector (socket) to connect the electrode. The interface includes the following signals: GND, Rx4, Rx3, Tx, Rx2, Rx1, and Rx0. Alternatively, the board-to-board connector can be replaced by a 1 mm Flexible Printed Circuitry (FPC) connector which is prepared as a design option. The five Rx channels of the MGC3130 (Rx0...Rx4) are connected to the receive electrodes via 10 k Ω resistors in order to suppress irradiated high-frequency signals (R11, R12, R13, R14, and R15). The MGC3130 signal generator is connected via the Tx signal to the transmit electrode.

The data connection to the Hillstar I²C to USB Bridge is realized by a 6-pin 2 mm board-to-board connector (header). The interface includes the following signals: EIO0, 3.3V, GND, SDA0, SCL0, and MCLR. Alternatively, it is possible to use a 1 mm FPC connector which can be assembled to the bottom side.

Hillstar Boards – Hardware Description

The MGC3130 unit acts as an I²C slave device. Table 3-1 shows the configuration of the MGC3130 interface selection pins (IS1, IS2) which can be pulled to V_{DD} or to GND via resistors (R3, R4, R5, and R6) to select the I²C slave address. The I²C device address 0x42 is set as default.

TABLE 3-1: MGC3130 UNIT I²C INTERFACE SELECTION

MGC3130 Interface Selection Pins		Mode (Address)	Assembly Option			
IS2	IS1		R3	R4	R5	R6
0	0	I ² C 0 Slave Address = 0x42 (default)	n.p.	10 kΩ	n.p.	10 kΩ
1	0	I ² C 0 Slave Address = 0x43	10 kΩ	n.p.	n.p.	10 kΩ

For Schematics, Layout and Bill of Material of the MGC3130 Unit please refer to [Section Appendix A. “Schematics”](#).

3.3 HILLSTAR 95x60 mm REFERENCE ELECTRODE

The 95x60 mm Reference Electrode provided with the Hillstar Development Kit consists of one Tx and a set of five Rx electrodes (north, east, south, west, center), which are placed in two different layers. An additional ground layer is placed underneath the Tx electrode and shields the electrode’s back from external influences.

FIGURE 3-3: HILLSTAR PCB ELECTRODE

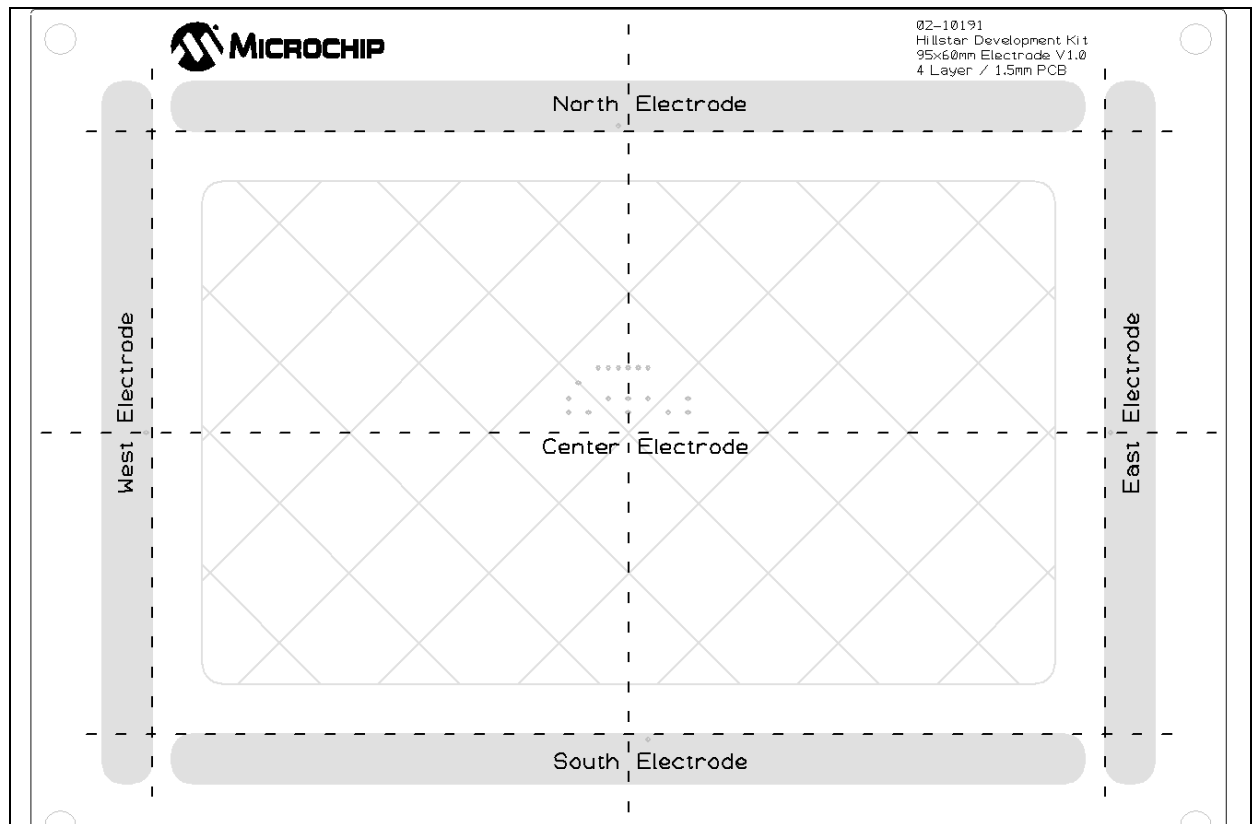

The PCB is connected to the MGC3130 Unit by the 2 mm 7-pin board-to-board connector. The interface includes the following signals: GND, Rx4, Rx3, Tx, Rx2, Rx1, and Rx0.

The dimension of the board is 120 x 85 mm; the sensitive area is 95 x 60 mm.

MGC3130 Hillstar Development Kit User's Guide

The five Rx electrodes include four frame electrodes and one center electrode, as shown in Figure 3-3. The frame electrodes are named according to their cardinal directions: north, east, south and west. The dimensions of the four Rx frame electrodes define the maximum sensing area. The center electrode is structured (cross-hatched) to get a similar input signal level as the four frame electrodes.

The Tx electrode spans over the complete area underneath the Rx electrodes. It is cross-hatched to reduce the capacitance between Rx and Tx (C_{RxTx}). The Tx area below the center electrode covers 50% of the copper plane, the area around only 20%.

The Rx feeding lines are embedded into the Tx electrode in the third layer (refer to Figure 3-4 and Figure 3-5). This supports shielding of the feeding lines.

Dimensions are given in Table 3-2.

FIGURE 3-4: ELECTRODE LAYOUT

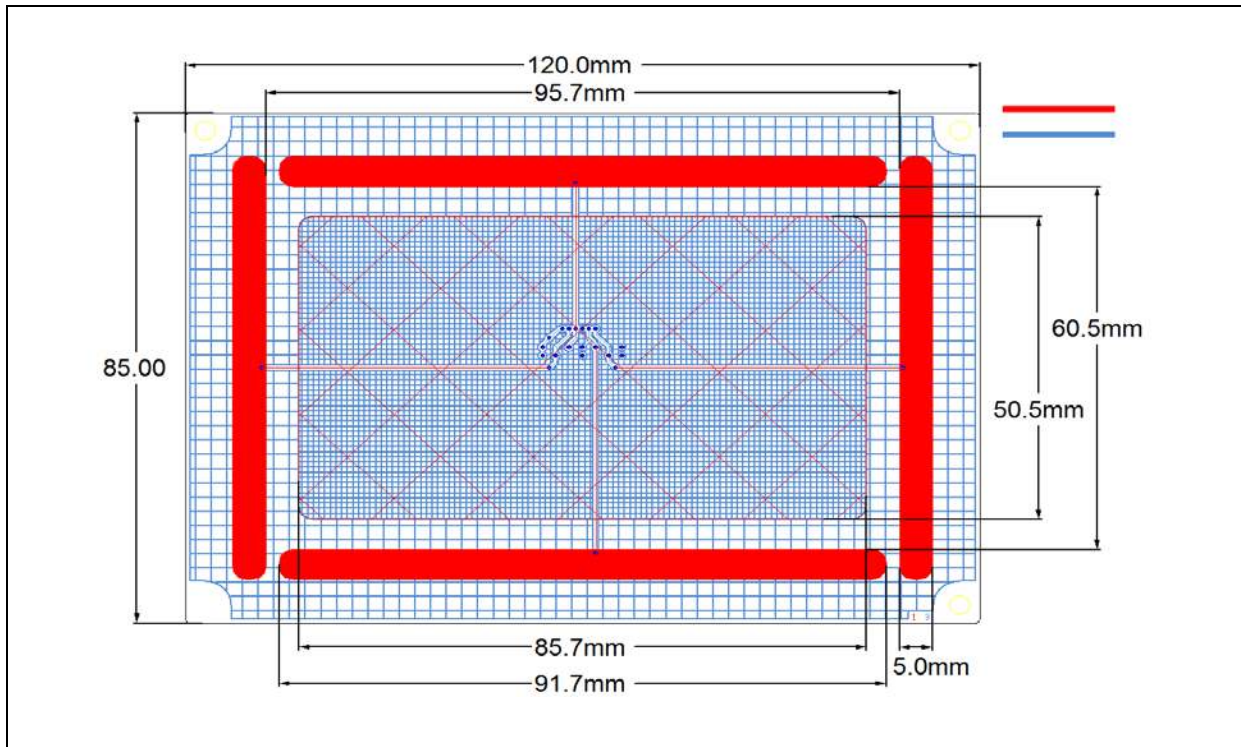

TABLE 3-2: HILLSTAR ELECTRODE DIMENSIONS

	Length	Width	Design
Horizontal Electrodes (Rx)	91.7 mm	5 mm	solid
Vertical Electrodes (Rx)	70.5 mm	5 mm	solid
Center Electrode (Rx)	85.7 mm	50.5 mm	3% cross-hatched
Tx Electrode (refer to Figure 3-4)			
Part I (under center electrode)	85.7 mm	50.5 mm	50% cross-hatched
Part II (outside Part I)	120 mm	85 mm	20% cross-hatched
Ground Area	120 mm	85 mm	solid

Hillstar Boards – Hardware Description

The electrode PCB is based on a 4-layer PCB design using FR4 material. Three functional layers are used:

- Layer 1 (Top): Rx electrodes
- Layer 3: Tx electrode and Rx feeding lines
- Layer 4 (Bottom): Ground

Layer 2 is not used.

FIGURE 3-5: PCB LAYER STACK

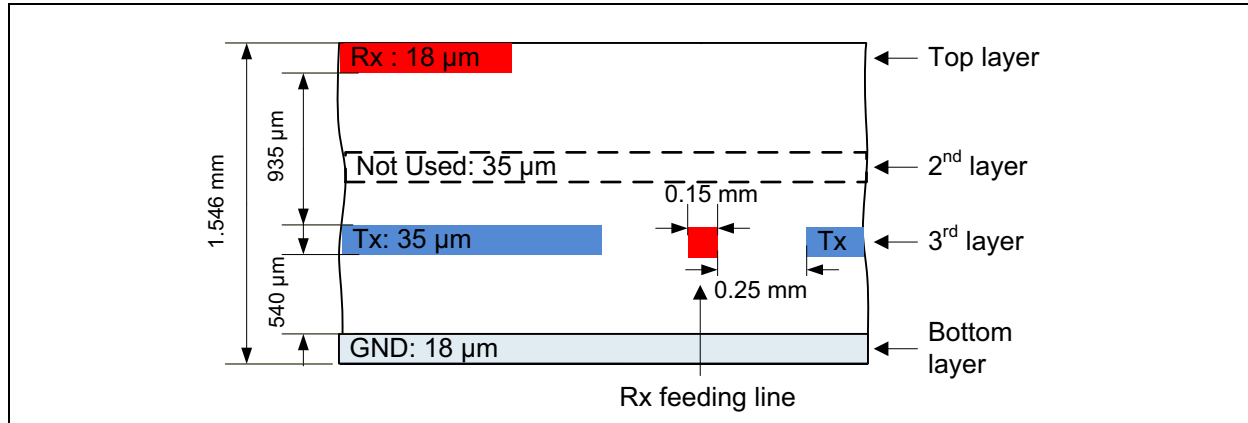

In a target system design the GND layer is not required. It is added for the Hillstar sensing electrode as a shielding layer and shall simulate the presence of static components which are placed in a target device underneath the sensing electrodes.

Note: Please refer to the “MGC3130 GestIC® Design Guide” for the electrodes equivalent circuitry, capacitances (C_{RxTx} , C_{RxG} , $TxRxG$) and their typical values.

3.4 I²C TO USB BRIDGE

Connecting the MGC3130 Unit to a PC requires an I²C to USB Bridge. The Hillstar Bridge works as a Composite Device Class (CDC). It controls the USB transfer towards the host PC and handles the I²C communication with the MGC3130 Unit. Moreover, it provides 3.3V power supply and the MCLR signal to the MGC3130 Unit.

The bridge function is handled by Microchip’s PIC18F14K50 USB microcontroller.

The board is equipped with a micro-USB connector (Type B) and a 2 mm 6-pin female board-to-board connector for the I²C interface. The interface to the MGC3130 Unit includes the following signals: EIO0, 3.3V, GND, SDA0, SCL0, and MCLR. Please refer to Figure 3-6.

MGC3130 Hillstar Development Kit User's Guide

FIGURE 3-6: I²C TO USB BRIDGE

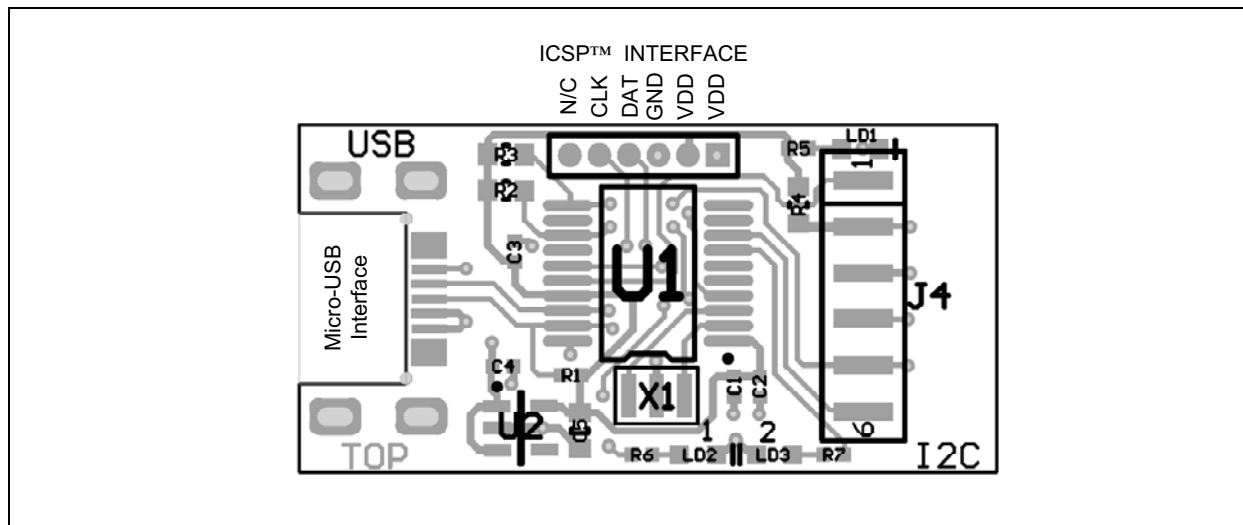

The I²C to USB Bridge is powered via the USB port. Microchip's Low Dropout (LDO) Voltage Regulator MCP1801 is used to transform the 5V USB power to 3.3V required for the PIC18F14K50. By default, 3.3V are also routed to the MGC3130 Unit via the I²C interface. The 3.3V power supply towards the MGC3130 Unit can be cut by removing the 0Ω resistor R7.

The LEDs indicate the following:

- POWER – signals that the I²C to USB Bridge is powered (3.3V)
- LED1 – blinks fast (~10 Hz) to indicate that there is no USB connection established
- LED1 – blinks slow (~1 Hz) to indicate that the USB connection is established
- LED 2 – is on when there is data on the I²C bus
- LED 2 – is off when there is no data on the I²C bus

The communication between Bridge and MGC3130 Unit is accomplished via a 2-wire I²C compatible serial port. Please refer to Figure 3-7.

In addition, the Hillstar Development Kit integrates an open-drain transfer status line (TS) and the MGC3130 MCLR signal, according to the MGC3130 reference circuitry. TS is connected to the RC0 pin of the PIC18F14K50 and MCLR to RC6.

For a detailed description of the I²C interface refer to the “MGC3130 Single-Zone 3D Gesture Controller Data Sheet” (DS40001667).

The default I²C address of the bridge is set to 0x42 but can also be switched to 0x43 by changing the firmware running on the PIC18F14K50.

Note: To update the PIC18F14K50 firmware, please refer to ‘MGC3130 PIC18F14K50 Host Reference Code’, available on www.microchip.com/GestICGettingStarted.

Hillstar Boards – Hardware Description

FIGURE 3-7: I²C AND USB DATA INTERFACE

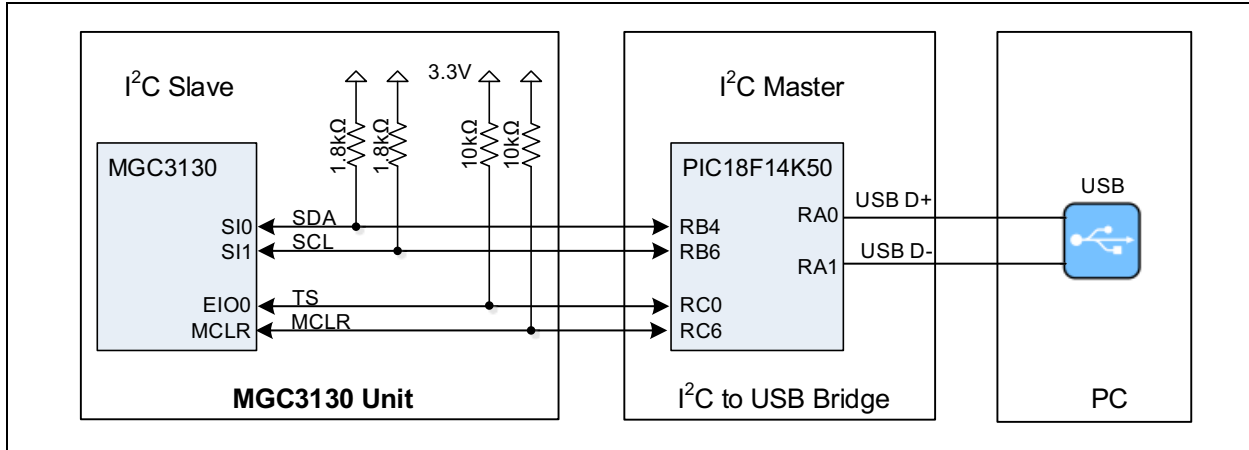

For Schematics, Layout and Bill of Material of the I²C to USB Bridge please refer to [Section Appendix A. "Schematics"](#).

MGC3130 Hillstar Development Kit User's Guide

NOTES:

Chapter 4. Design In: Hillstar In Target Application

4.1 INTRODUCTION

The Hillstar Development Kit is designed to support an easy integration of Microchip's MGC3130 3D Gesture and Tracking Controller into customer's applications.

The three Hillstar PCBs can be plugged to a PC via USB cable and used for evaluation of MGC3130 chip and GestIC technology.

During the customer's design-in process the individual boards can be combined according to the customers need.

Three examples are given below:

- Combine MGC3130 Unit and I²C to USB Bridge to evaluate customized electrodes
- Use I²C to USB Bridge to parameterize and debug the MGC3130 application circuitry in the customer's design (in-circuit)
- Combine MGC3130 Unit and Electrodes to develop gesture-driven applications for PC-based or embedded software environments

For in-circuit parameterization and debugging it is mandatory to control the MGC3130 via Aurea Control Software. For that purpose, the customer's application should provide an appropriate hardware or software interface.

4.2 INTEGRATION EXAMPLES

The following figures show typical hardware circuits for MGC3130 integration into a customer's application.

Figure 4-1 and Figure 4-2 show the control via I²C and an external PC. The Hillstar I²C to USB Bridge acts as an I²C master, the application processor I²C should be:

- Switched off (I²C lines configured as high Z, refer to Figure 4-1)
- Switched to Slave or Listen mode or
- Disconnected (through an external switch, refer to Figure 4-2)

As an alternative, it is also possible to establish an USB connection between the application processor and a PC without using an I²C to USB Bridge. Please refer to Figure 4-3.

MGC3130 Hillstar Development Kit User's Guide

FIGURE 4-1: MGC3130 PARAMETERIZATION CIRCUIT WITH INTERNAL SWITCH

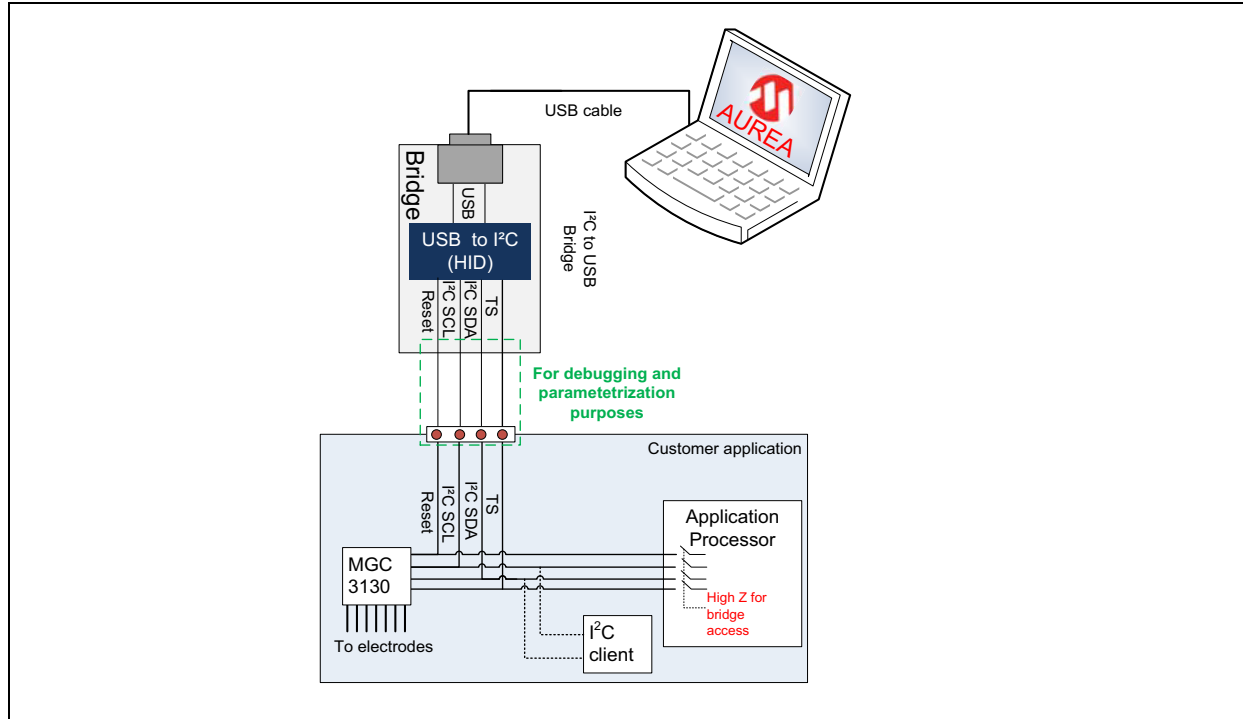
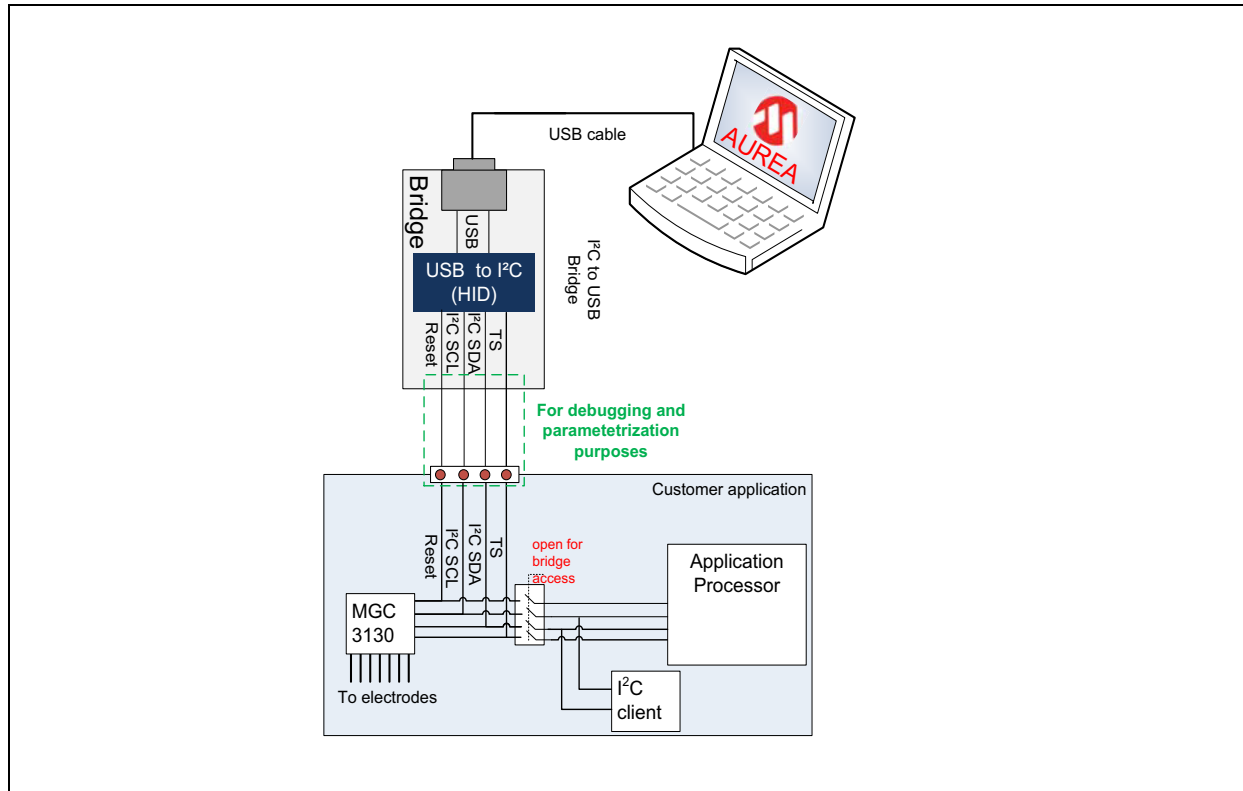

FIGURE 4-2: MGC3130 PARAMETERIZATION CIRCUIT WITH EXTERNAL SWITCH



Design In: Hillstar In Target Application

FIGURE 4-3: MGC3130 PARAMETERIZATION CIRCUIT FOR USB BASED APPLICATIONS

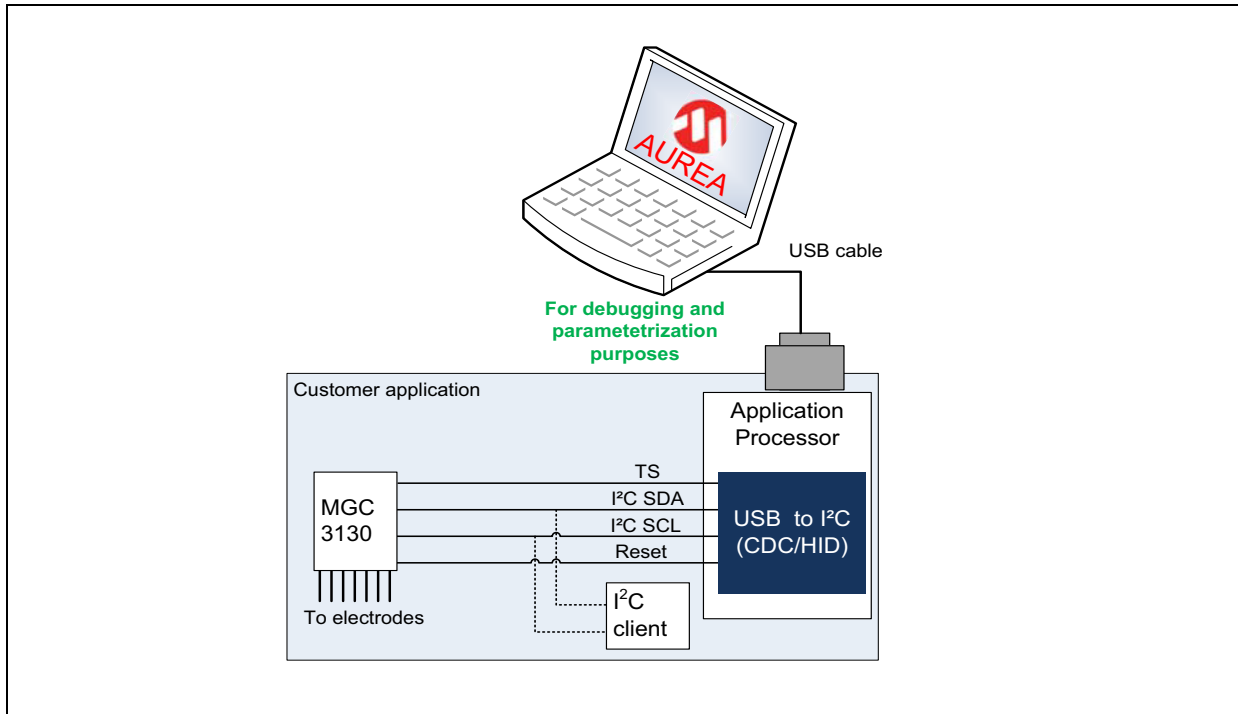

TABLE 4-1: MGC3130 PARAMETERIZATION CIRCUITS COMPARISON

Parameterization Circuit	Advantages	Drawbacks
With Internal Switch	Easy Approach	Processor pins need to be switchable to high Z
	Low hardware efforts	No other clients can be controlled during Aurea access
With External Switch	Communication to other I ² C clients not interrupted	Additional hardware switch
USB Based Applications	No hardware efforts	Additional software efforts
	Works if other I ² C clients connected to the bus	

MGC3130 Hillstar Development Kit User's Guide

NOTES:

Chapter 5. Troubleshooting

Troubleshooting Information

Power LED does not illuminate

In case the power LED does not illuminate it is likely that the board is not powered.

Possible Solutions:

- Check the board is connected to your PC's USB port.
- Change the USB cable or use a different USB port on your PC.
- Check if the PC is switched on.

LED 1 blinks fast

When LED 1 blinks fast (~10 Hz) the USB connection is not established towards the PC.

Possible Solutions:

- Make sure the Windows CDC driver is installed (refer to [Appendix D. "Driver Installation Manual"](#)).
- Make sure the MGC3130 Unit and the I²C to USB Bridge are already connected before plugging in the USB connection (refer to [Section 2.2 "Step 1: Build-up Development Kit"](#)).
- Reconnect the board by unplugging and plugging in again the USB connection.

Signal streaming stops

Signal stream in Aurea GUI stops when there is no approach towards the sensing area. This behavior is intended. When using the Aurea GUI, the Wake-up on Approach feature is automatically enabled.

Possible Solutions:

Disable the Wake-up on Approach feature in the Real-Time Control bar of Aurea by unchecking the Approach Detection/Power Saving check box for continuous signal streaming.

No Position data displayed, Electrode signals are zero

Signal matching parameters have been mismatched and accidentally stored into the Flash.

Possible Solutions:

- Perform "Autoparameterization" in the AFE Parameterization of **Aurea Setup** tab. Make sure there is no hand approach towards the electrodes during autoparamterization process.
- Restore the default Signal Matching parameters by re-flashing the original MGC3130 GestIC[®] Library file.

LED 1 and 2 on I²C to USB Bridge are Off

When LED 1 and LED 2 on the I²C to USB Bridge are Off but the power LED is On, the PIC18F14K50 is in Bootloader Update mode and therefore not operating code. The PIC18F14K50 will start in Bootloader Update mode in case the MGC3130 Unit is not connected to the I²C to USB Bridge.

Possible Solutions:

- Please disconnect the I²C to USB Bridge from USB. Connect the MGC3130 Unit and the I²C to USB Bridge first and then plug in the USB connection.

MGC3130 Hillstar Development Kit User's Guide

NOTES:

Appendix A. Schematics

A.1 INTRODUCTION

This appendix contains the MGC3130 Hillstar Development Kit schematic and Bill of Materials.

A.2 BILL OF MATERIALS

TABLE A-1: I²C TO USB BRIDGE BILL OF MATERIALS

Qty.	Description	Name
1	Connector, Micro-USB 5-pin Type B, SMD	BU1
1	Connector, 2 mm socket 6-pin, SMD	BU2
1	Capacitor, 100 nF, 10%, X7R, SMD 0402	C1
3	Capacitor, 1 μF, 10%, X5R, 10 V, SMD 0402	C2, C3, C5
1	Capacitor, 10 μF, 20%, X5R, 6.3 V, SMD 0603	C4
3	LED, 571 nm, green clear, 0603 SMD	D1, D2, D3
1	IC, MCP1801T LDO, Voltage Regulator, 3.3V, 150 mA, 5-Pin SOT-23	IC1
1	IC, PIC18F14K50 USB Flash Microcontroller, 20-Pin SSOP	IC2
3	Resistor, 1 kΩ, 1%, 1/16W, SMD 0402	R3, R4, R6
1	Resistor, 150 kΩ, 1%, 1/16W, SMD 0402	R5
1	Resistor, 0 kΩ, 1%, 1/16W, SMD 0603	R7
1	Crystal, 12 MHz, 33 pF, SMD	XTAL1

TABLE A-2: HILLSTAR – I²C TO USB BRIDGE MOUNTING OPTION

Qty.	Description	Name
1	Connector, 1 mm FPC 6-pin, SMD	ST1

MGC3130 Hillstar Development Kit User's Guide

TABLE A-3: HILLSTAR – MGC3130 UNIT BILL OF MATERIALS

Qty.	Description	Name
1	Connector, 2 mm socket 7-pin, SMD	BU1
1	Connector, 2 mm header 6-pin, SMD	ST1
1	Capacitor, 100 nF, 10%, X7R, SMD 0402	C1
2	Capacitor, 4,7 μ F, 20%, X5R, 6.3V, SMD 0402	C2, C3
1	LED, 571 nm green clear, 0603 SMD	D2
1	IC, MGC3130, 28-Pin QFN	IC1
2	Resistor, 1,8 k Ω , 1%, 1/16W, SMD 0402	R1, R2
8	Resistor, 10 k Ω , 1%, 1/16W, SMD 0603	R4, R6, R7, R11, R12, R13, R14, R15
1	Resistor, 0 k Ω , 1%, 1/16W, SMD 0402	R16
1	Resistor, 10 k Ω , 1%, 1/16W, SMD 0402	R17
1	Resistor, 1 k Ω , 1%, 1/16W, SMD 0402	R18

TABLE A-4: HILLSTAR – MGC3130 UNIT MOUNTING OPTION

Qty.	Description	Name
1	Connector, 1 mm FPC 6-pin, SMD	ST3

A-5: HILLSTAR – ELECTRODE BILL OF MATERIALS

Qty.	Description	Name
1	Connector, 2 mm header 7-pin, SMD	ST1

A.3 BOARD – SCHEMATICS AND LAYOUT

FIGURE A-1: HILLSTAR GestIC® UNIT SCHEMATIC

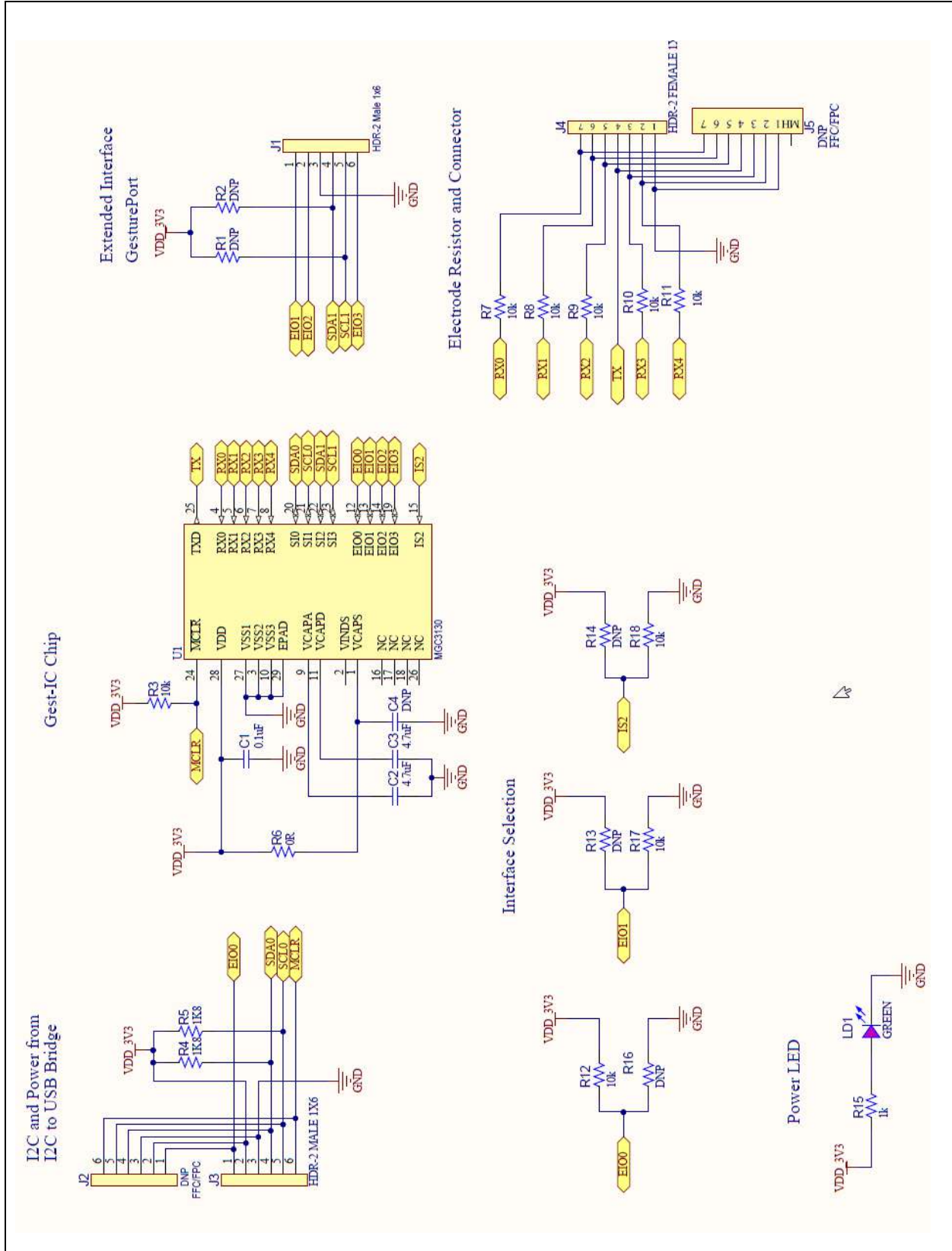

MGC3130 Hillstar Development Kit User's Guide

FIGURE A-2: ASSEMBLY OF MGC3130 UNIT

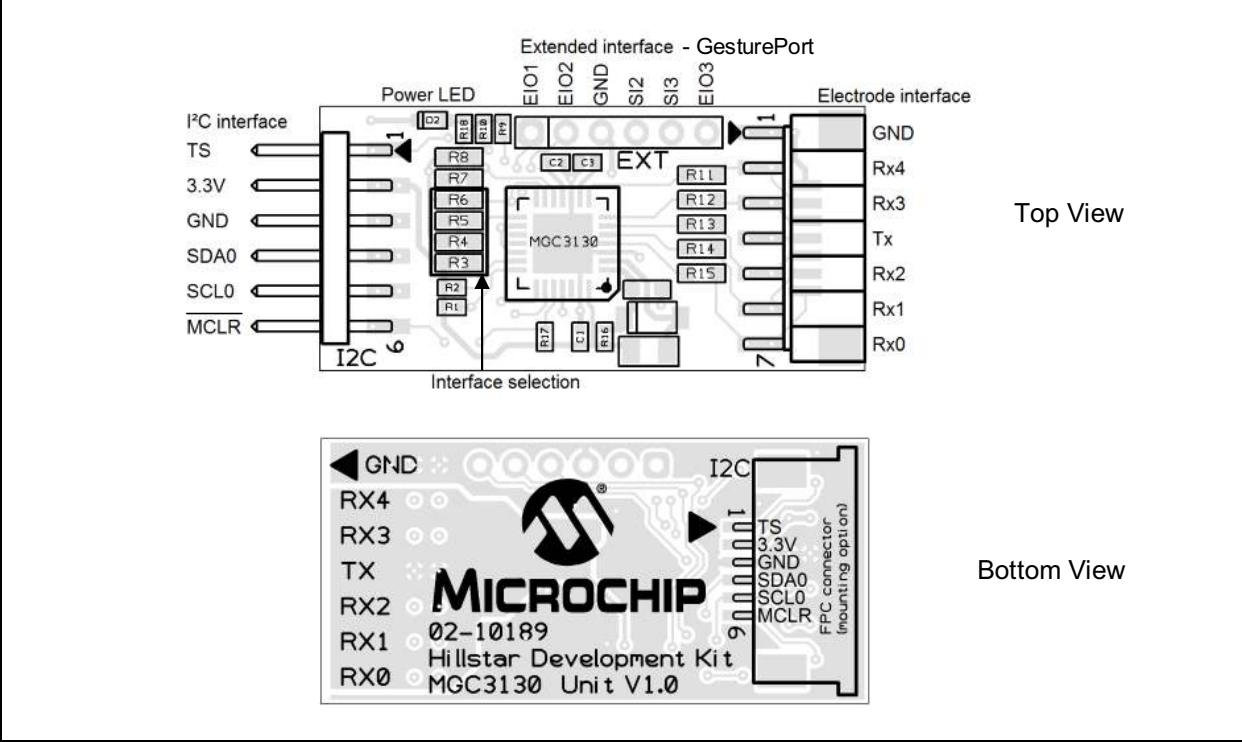
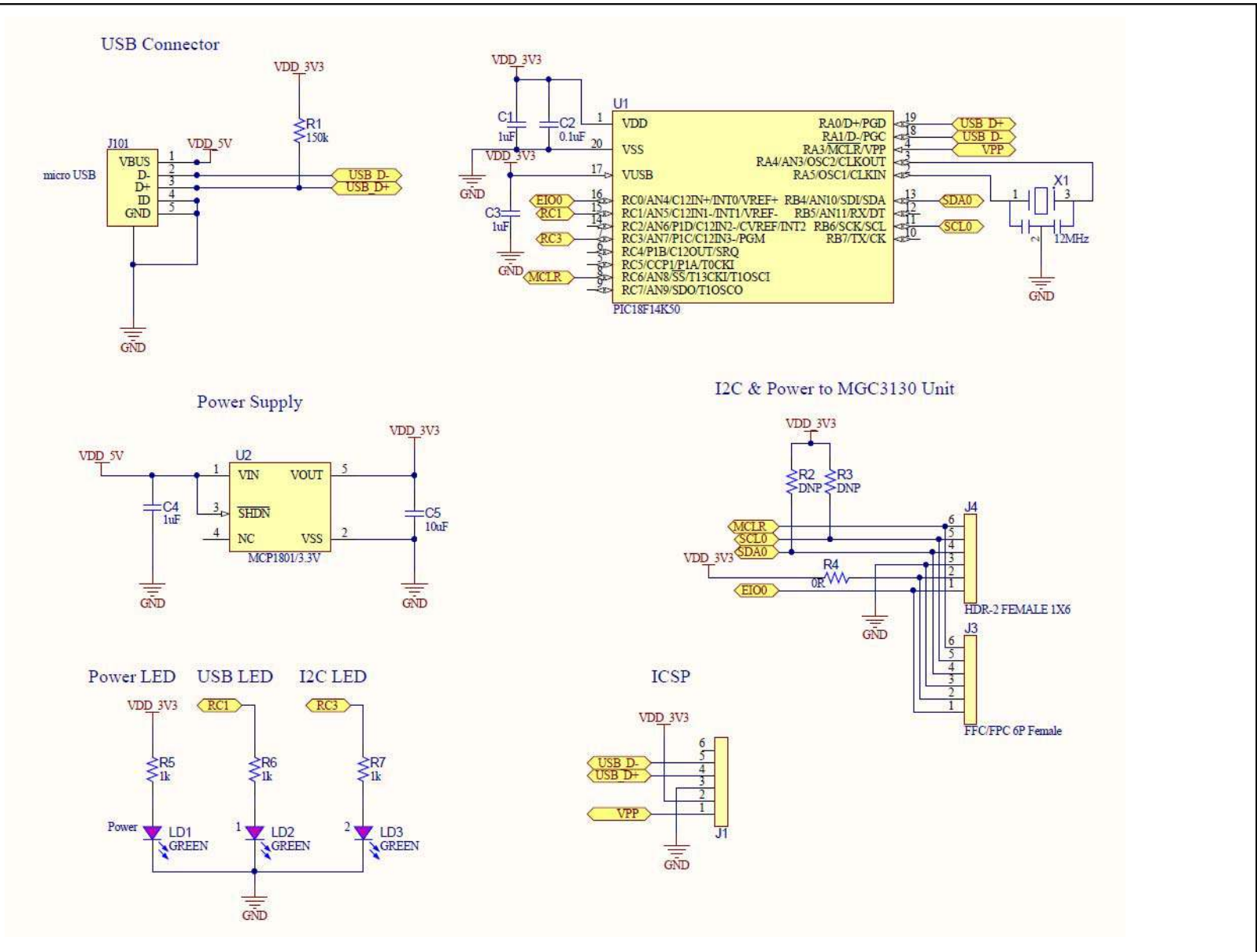
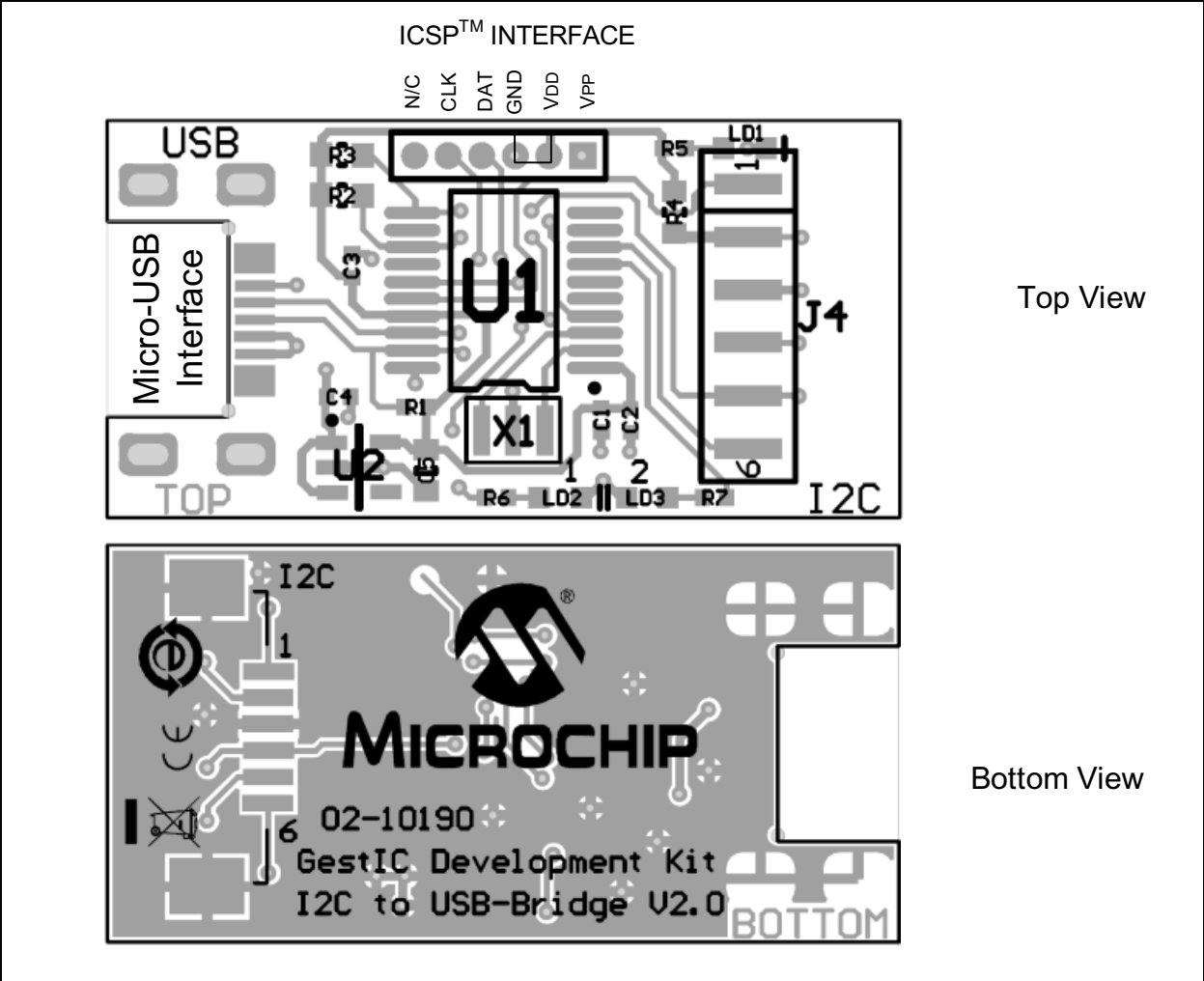

FIGURE A-3: HILLSTAR I²C TO USB BRIDGE SCHEMATIC



MGC3130 Hillstar Development Kit User's Guide

FIGURE A-4: ASSEMBLY OF HILLSTAR I²C TO USB BRIDGE



Appendix B. Sensitivity Profile and Capacitances

B.1 INTRODUCTION

This appendix contains the sensitivity profile and the electrode capacitances of the Hillstar Development Kit hardware.

The measurement procedure of both, the sensitivity profile and the electrode capacitances are outlined in "MGC3130 GestIC® Design Guide".

B.2 SENSITIVITY PROFILES

The sensitivity profiles were conducted using a 40x40x70 mm hand brick and a 30 mm spacer brick.

FIGURE B-1: SENSITIVITY PROFILE FROM WEST TO EAST

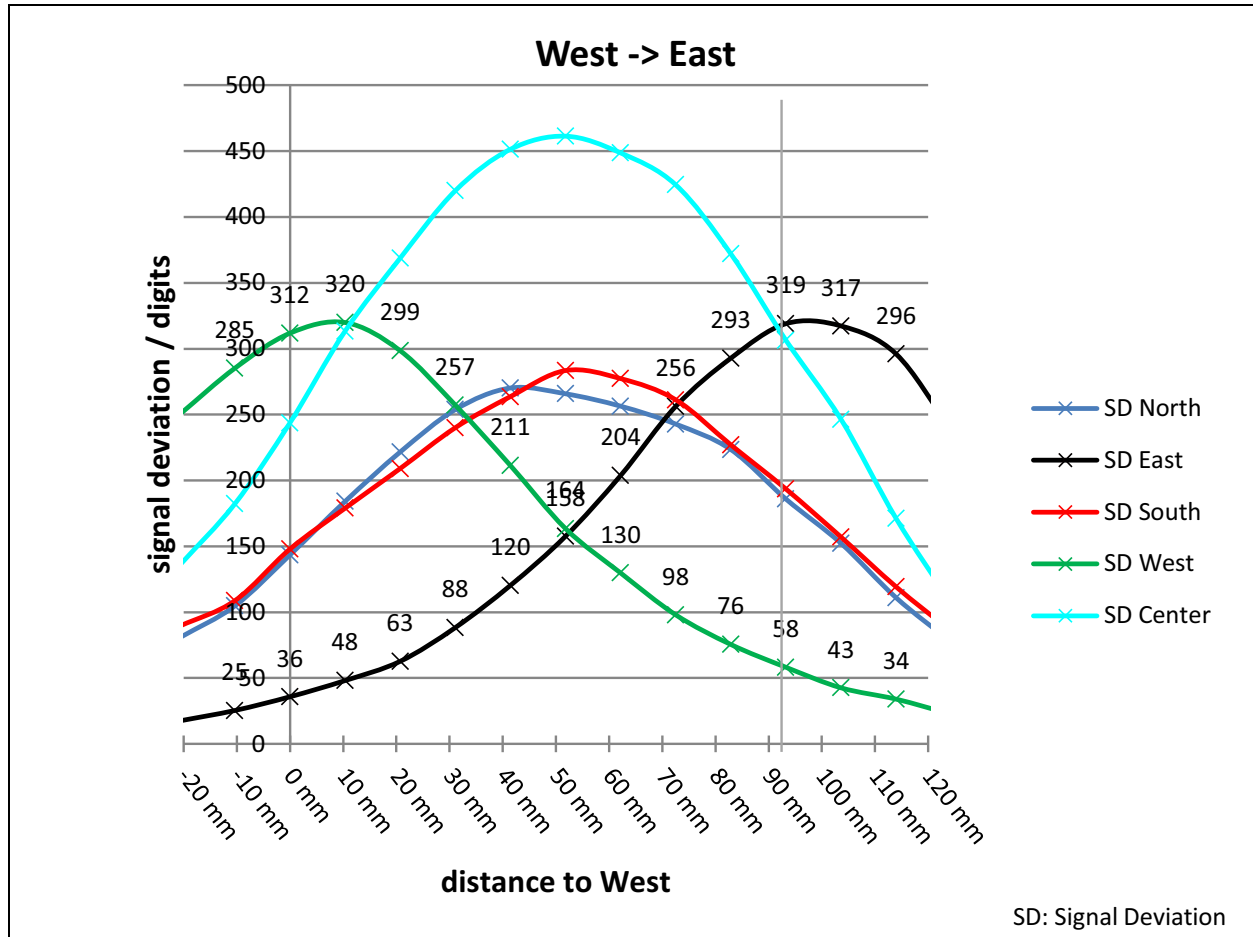

MGC3130 Hillstar Development Kit User's Guide

FIGURE B-2: SENSITIVITY PROFILE FROM NORTH TO SOUTH

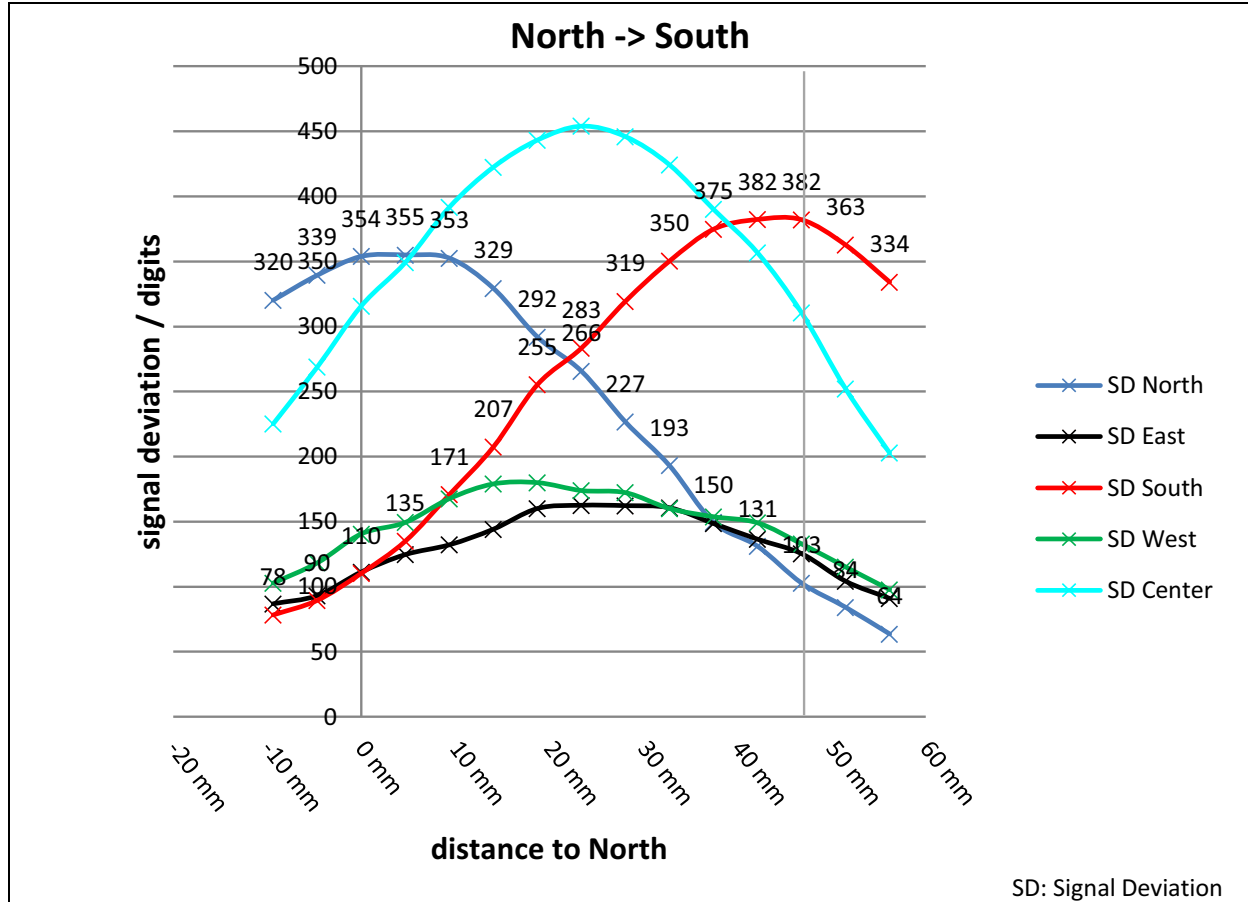

B.3 ELECTRODE CAPACITIES

The capacitances between the Rx electrodes and GND (C_{RXG}) does not include the 5 pF input capacitance of the MGC3130 Rx input buffer (C_{Buf}).

TABLE B-3: HILLSTAR ELECTRODE CAPACITIES

Channel	C_{RXG}	C_{RXTX}
North	9 pF	20 pF
East	9 pF	18 pF
South	9 pF	20 pF
West	8 pF	18 pF
Center	7 pF	65 pF

$$C_{TXG} = 590 \text{ pF}$$

Appendix C. Parameterization Support

C.1 HOW TO BUILD A HAND BRICK

For parameterization and performance evaluation of the customer's electrode design, the Hillstar Development Kit contains a set of hand and spacer bricks. The hand brick is a conductive block of 40x40x70 mm and represents a human hand. It must be connected to ground via cable in order to simulate the grounding conditions of the human body.

The Hillstar package contains an assembly set to build the hand brick consisting of a Styrofoam block (40x40x70 mm) and an adhesive copper foil.

The following section explains how to assemble the hand brick.

1. **Take the copper layer and the Styrofoam block with the dimensions of (40x40x70 mm).**



2. **Revert the copper layer and remove the glue foil.**

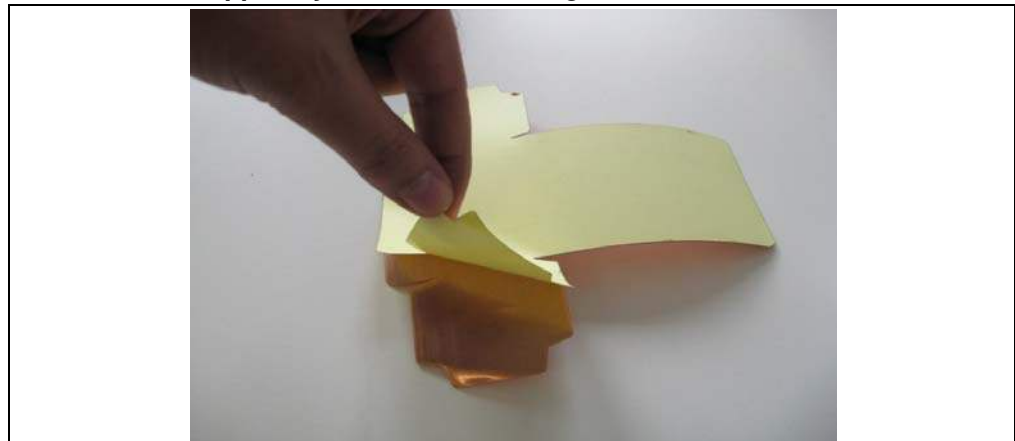

MGC3130 Hillstar Development Kit User's Guide

3. Place the Styrofoam block on the copper layer exactly on the middle. Be careful to be accurate! Fold the copper. Follow along the inside lines, and fold the copper inward. Start with right, left sides and then with middle part. Align the folds.



4. Finish up your box. Tape all of the sides together, and you're done.



5. Solder a thin wire (approx. 50 cm) on the top of the brick which will be connected later to ground.

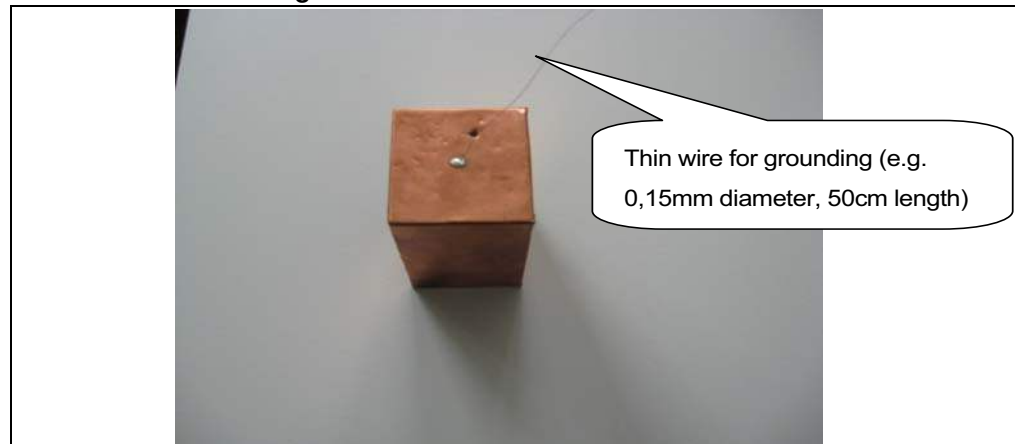

6. Finished.

C.2 USAGE OF THE HAND BRICK AS ARTIFICIAL HAND

For parameterization and performance evaluation purposes of the customer's electrode design, the kit contains a set of hand and spacer bricks. This artificial hand brick simulates Human Hand effect and is made of a Styrofoam block covered with light copper and has a fixed size. Spacer bricks (Styrofoam block without copper layer) are used to position the hand brick in different heights to the electrode. Because of a $\epsilon_r \approx 1$ of Styrofoam, the spacer brick does not influence the measurement results.

For quick parameterization, the ground wire connected to the hand brick should be maintained using your hand which emulates the ground connection. The wire should be hold at 50 cm minimum and the line should also be straight to avoid any influence to the system sensitivity as shown in Figure C-1.

For parameterization process, please refer to "*MGC3130 GestIC[®] Design Guide*" and the appropriate wizards in Aurea PC software.

FIGURE C-1: USAGE OF ARTIFICIAL HAND

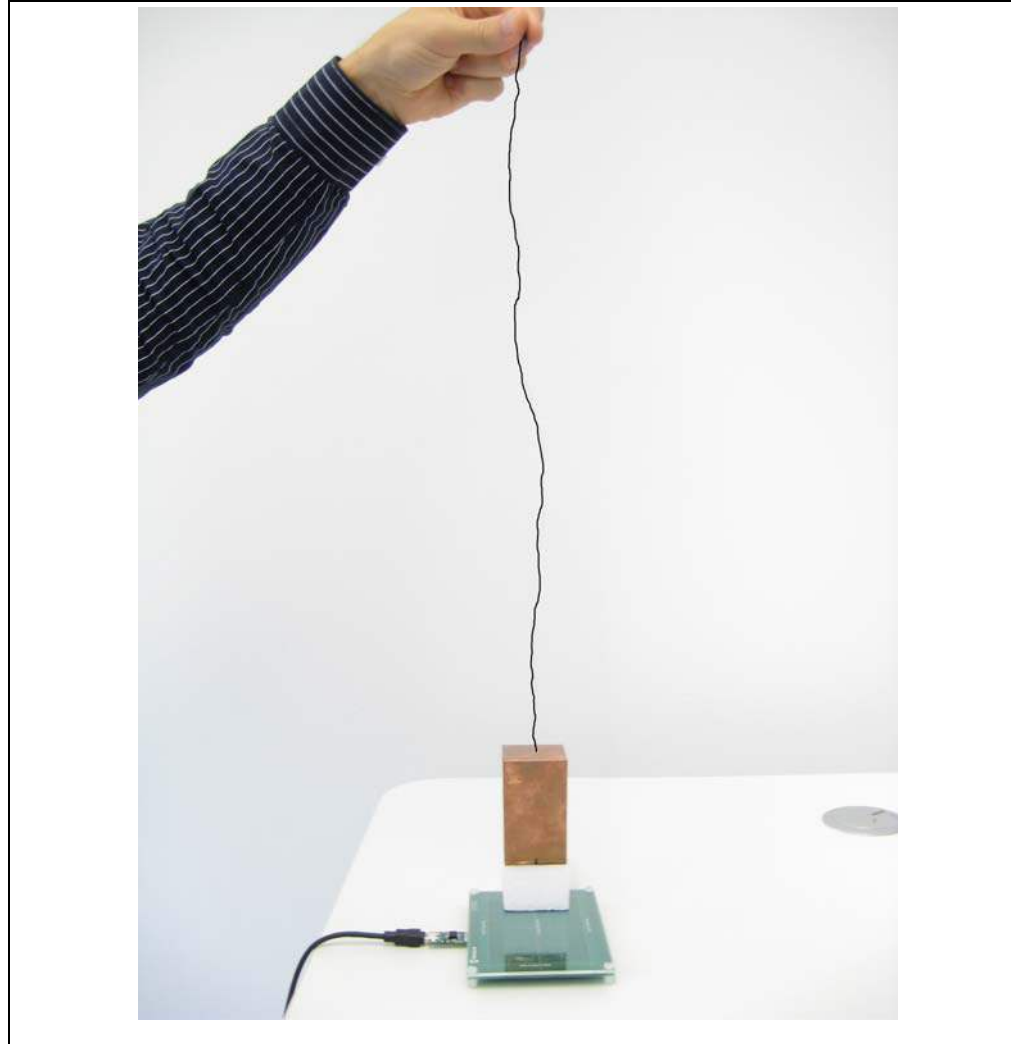

Appendix D. Driver Installation Manual

Go through the following steps to manually install the Windows CDC Driver on your PC.

D.1 OPEN DEVICE MANAGER

While the Hillstar Development Board is connected to your PC press **Start**, right-click on **Computers** and select **Manage**. This will bring up the **Computer Management** window shown in Figure D-1. On the left sidebar select **Device Manager**.

FIGURE D-1: COMPUTER MANAGEMENT

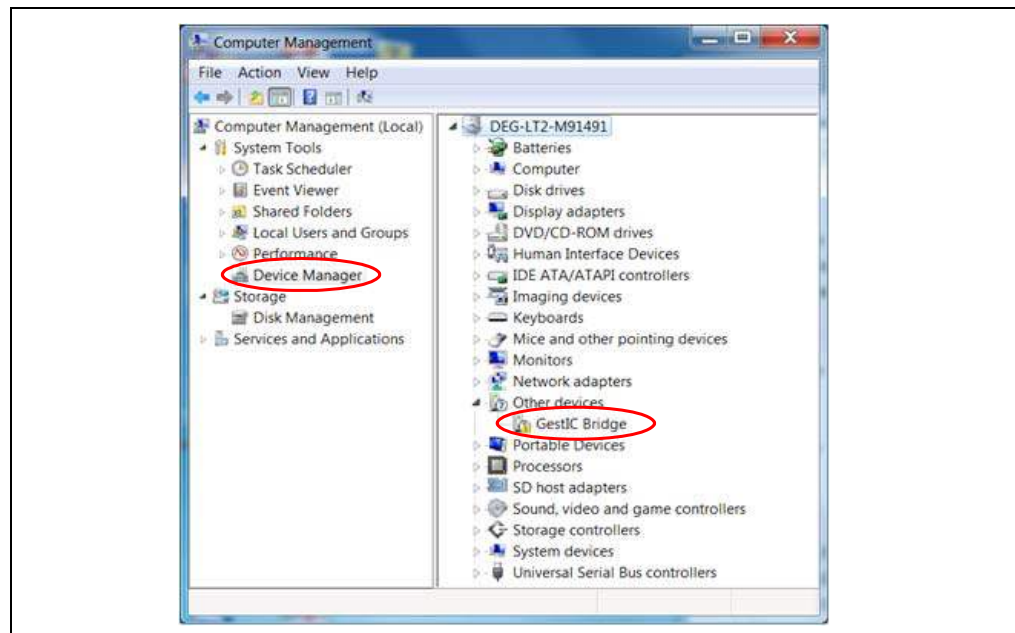

D.2 SELECT DEVICE

1. Right Click on **GestIC Bridge** and select **Update Driver Software**.
2. Select **Search Method**
3. The window shown in Figure D-2 will open. Choose **Browse my Computer** for driver software.

FIGURE D-2: Update Driver Software

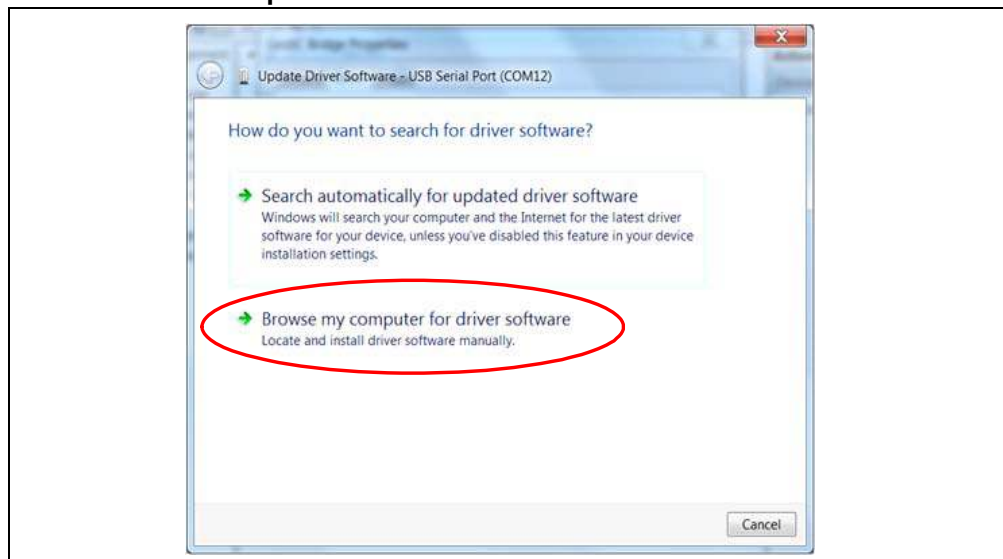

D.3 LOCATE DRIVER

1. Click **Browse** and navigate to the driver files on your local drive (refer to Figure D-3).
2. Press **Next** and the driver will be installed.

FIGURE D-3: Browse for Driver Software

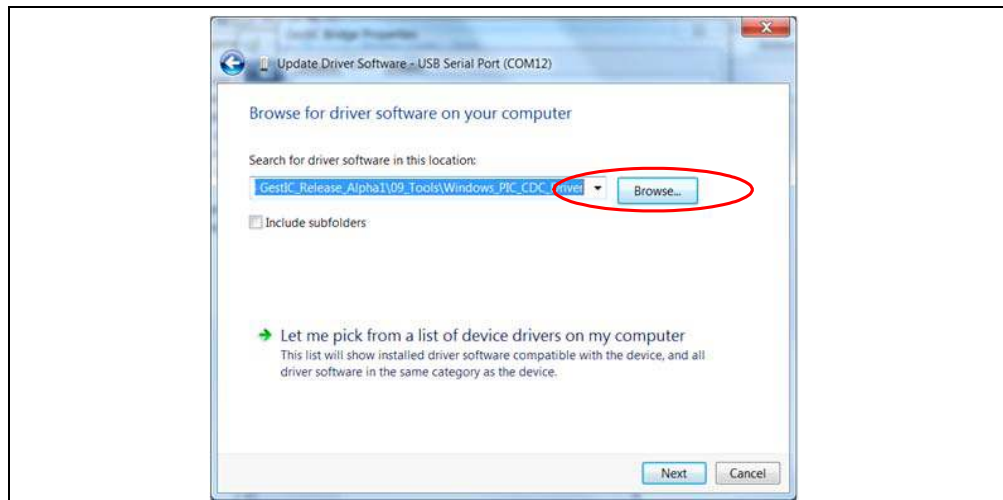

D.4 VERIFY COMMUNICATION

The driver is properly installed and the communication between the PC and the Hillstar Development Board is successfully established when LED 1 and LED 2 blink alternatively.

Appendix E. Glossary

TABLE E-1: GestIC® GLOSSARY

Term	Definition
AFE	Analog front end
Application Host	PC or embedded controller which controls the MGC3130
Aurea	MGC3130 PC control software with graphical user interface
Colibri Suite	Embedded DSP suite within the GestIC® Library
Deep Sleep	MGC3130 Power-Saving mode
E-field	Electrical field
Frame Electrodes	Rectangular set of four electrodes for E-field sensing
GestIC Technology	Microchip's patented technology providing 3D free-space gesture recognition utilizing the principles of electrical near-field sensing
GestIC Library	Includes the implementation of MGC3130 features and is delivered as a binary file preprogrammed on the MGC3130
Gesture Recognition	Microchip's stochastic HMM classifier to automatically detect and classify hand movement patterns
Gesture Set	A set of provided hand movement patterns
Hand Brick	Copper coated test block (40x40x70 mm)
HMM	Hidden Markov Model
MGC3130	Single-Zone 3D Gesture Sensing Controller
Position Tracking	GestIC technology feature
Sabrewing	MGC3130 evaluation board
Self Wake-up	MGC3130 Power-Saving mode
Sensing Area	Area enclosed by the four frame electrodes
Sensing Space	Space above sensing area
Signal Deviation	Term for the delta of the sensor signal on approach of the hand versus non-approach
Spacer Brick	Spacer between the sensor layer and hand brick (Styrofoam block 40x40xh mm) with h= 1 / 2 / 3 / 5 / 8 / 12 cm
SPU	Signal Processing Unit
Approach Detection	GestIC technology feature: Power-Saving mode of the MGC3130 with approach detection

MGC3130 Hillstar Development Kit User's Guide

NOTES:



MICROCHIP

Worldwide Sales and Service

AMERICAS

Corporate Office

2355 West Chandler Blvd.
Chandler, AZ 85224-6199
Tel: 480-792-7200
Fax: 480-792-7277
Technical Support:
<http://www.microchip.com/support>

Web Address:
www.microchip.com

Atlanta

Duluth, GA
Tel: 678-957-9614
Fax: 678-957-1455

Austin, TX

Tel: 512-257-3370

Boston

Westborough, MA
Tel: 774-760-0087
Fax: 774-760-0088

Chicago

Itasca, IL
Tel: 630-285-0071
Fax: 630-285-0075

Cleveland

Independence, OH
Tel: 216-447-0464
Fax: 216-447-0643

Dallas

Addison, TX
Tel: 972-818-7423
Fax: 972-818-2924

Detroit

Novi, MI
Tel: 248-848-4000

Houston, TX

Tel: 281-894-5983

Indianapolis

Noblesville, IN
Tel: 317-773-8323
Fax: 317-773-5453

Los Angeles

Mission Viejo, CA
Tel: 949-462-9523
Fax: 949-462-9608

New York, NY

Tel: 631-435-6000

San Jose, CA

Tel: 408-735-9110

Canada - Toronto

Tel: 905-673-0699
Fax: 905-673-6509

ASIA/PACIFIC

Asia Pacific Office

Suites 3707-14, 37th Floor
Tower 6, The Gateway
Harbour City, Kowloon

Hong Kong

Tel: 852-2943-5100
Fax: 852-2401-3431

Australia - Sydney

Tel: 61-2-9868-6733
Fax: 61-2-9868-6755

China - Beijing

Tel: 86-10-8569-7000
Fax: 86-10-8528-2104

China - Chengdu

Tel: 86-28-8665-5511
Fax: 86-28-8665-7889

China - Chongqing

Tel: 86-23-8980-9588
Fax: 86-23-8980-9500

China - Dongguan

Tel: 86-769-8702-9880

China - Hangzhou

Tel: 86-571-8792-8115
Fax: 86-571-8792-8116

China - Hong Kong SAR

Tel: 852-2943-5100
Fax: 852-2401-3431

China - Nanjing

Tel: 86-25-8473-2460
Fax: 86-25-8473-2470

China - Qingdao

Tel: 86-532-8502-7355
Fax: 86-532-8502-7205

China - Shanghai

Tel: 86-21-5407-5533
Fax: 86-21-5407-5066

China - Shenyang

Tel: 86-24-2334-2829
Fax: 86-24-2334-2393

China - Shenzhen

Tel: 86-755-8864-2200
Fax: 86-755-8203-1760

China - Wuhan

Tel: 86-27-5980-5300
Fax: 86-27-5980-5118

China - Xian

Tel: 86-29-8833-7252
Fax: 86-29-8833-7256

ASIA/PACIFIC

China - Xiamen

Tel: 86-592-2388138
Fax: 86-592-2388130

China - Zhuhai

Tel: 86-756-3210040
Fax: 86-756-3210049

India - Bangalore

Tel: 91-80-3090-4444
Fax: 91-80-3090-4123

India - New Delhi

Tel: 91-11-4160-8631
Fax: 91-11-4160-8632

India - Pune

Tel: 91-20-3019-1500

Japan - Osaka

Tel: 81-6-6152-7160
Fax: 81-6-6152-9310

Japan - Tokyo

Tel: 81-3-6880-3770
Fax: 81-3-6880-3771

Korea - Daegu

Tel: 82-53-744-4301
Fax: 82-53-744-4302

Korea - Seoul

Tel: 82-2-554-7200
Fax: 82-2-558-5932 or
82-2-558-5934

Malaysia - Kuala Lumpur

Tel: 60-3-6201-9857
Fax: 60-3-6201-9859

Malaysia - Penang

Tel: 60-4-227-8870
Fax: 60-4-227-4068

Philippines - Manila

Tel: 63-2-634-9065
Fax: 63-2-634-9069

Singapore

Tel: 65-6334-8870
Fax: 65-6334-8850

Taiwan - Hsin Chu

Tel: 886-3-5778-366
Fax: 886-3-5770-955

Taiwan - Kaohsiung

Tel: 886-7-213-7828

Taiwan - Taipei

Tel: 886-2-2508-8600
Fax: 886-2-2508-0102

Thailand - Bangkok

Tel: 66-2-694-1351
Fax: 66-2-694-1350

EUROPE

Austria - Wels

Tel: 43-7242-2244-39
Fax: 43-7242-2244-393

Denmark - Copenhagen

Tel: 45-4450-2828
Fax: 45-4485-2829

France - Paris

Tel: 33-1-69-53-63-20
Fax: 33-1-69-30-90-79

Germany - Dusseldorf

Tel: 49-2129-3766400

Germany - Karlsruhe

Tel: 49-721-625370

Germany - Munich

Tel: 49-89-627-144-0
Fax: 49-89-627-144-44

Italy - Milan

Tel: 39-0331-742611
Fax: 39-0331-466781

Italy - Venice

Tel: 39-049-7625286

Netherlands - Drunen

Tel: 31-416-690399
Fax: 31-416-690340

Poland - Warsaw

Tel: 48-22-3325737

Spain - Madrid

Tel: 34-91-708-08-90
Fax: 34-91-708-08-91

Sweden - Stockholm

Tel: 46-8-5090-4654

UK - Wokingham

Tel: 44-118-921-5800
Fax: 44-118-921-5820

07/14/15