

## HFA3767

### 130MHz CDMA/AMPS Quadrature Modular and AGC

The HFA3767 is a monolithic bipolar quadrature modulator with gain control for CDMA/AMPS cellular applications. An upconverter quadrature mixer and an output gain control stage with better than 70dB of dynamic range are integrated in the design. A local oscillator input requires low drive levels and a divide by two phase shifter with duty cycle compensation achieves excellent phase and amplitude balance properties. The HFA3767 is one of the four chips in the PRISM™ chip set and is housed in a 20 lead SSOP package ideally suited to cellular handset applications.

#### Rochester Electronics Manufactured Components

Rochester branded components are manufactured using either die/wafers purchased from the original suppliers or Rochester wafers recreated from the original IP. All re-creations are done with the approval of the Original Component Manufacturer (OCM).

Parts are tested using original factory test programs or Rochester developed test solutions to guarantee product meets or exceeds the OCM data sheet.

#### Quality Overview

- ISO-9001
- AS9120 certification
- Qualified Manufacturers List (QML) MIL-PRF-35835
  - Class Q Military
  - Class V Space Level
- Qualified Suppliers List of Distributors (QSLD)
  - Rochester is a critical supplier to DLA and meets all industry and DLA standards.

Rochester Electronics, LLC is committed to supplying products that satisfy customer expectations for quality and are equal to those originally supplied by industry manufacturers.

*The original manufacturer's datasheet accompanying this document reflects the performance and specifications of the Rochester manufactured version of this device. Rochester Electronics guarantees the performance of its semiconductor products to the original OCM specifications. 'Typical' values are for reference purposes only. Certain minimum or maximum ratings may be based on product characterization, design, simulation, or sample testing.*

FOR REFERENCE ONLY

## PRELIMINARY

February 1998

## 130MHz CDMA/AMPS Quadrature Modulator and AGC

### Features

- I/Q Amplitude and Phase Balance ..... 0.5dB, 2°
- 130MHz AGC Amplifier/Attenuator range ..... >70dB
- Low LO Drive Level ..... -10dBm
- Power Enable/Disable Control
- Single Supply Battery Operation ..... 2.7 to 3.3V

### Applications

- IS95A CDMA/AMPS Dual Mode Handsets
- Wideband CDMA Handsets
- Full Duplex Transceivers
- CDMA/TDMA Packet Protocol Radios
- Portable Battery Powered Equipment



### Description

The HFA3767 is a monolithic bipolar quadrature modulator with gain control for CDMA/AMPS cellular applications. An upconverter quadrature mixer and an output gain control stage with better than 70dB of dynamic range are integrated in the design. A local oscillator input requires low drive levels and a divide by two phase shifter with duty cycle compensation achieves excellent phase and amplitude balance properties. The HFA3767 is one of the four chips in the PRISM™ chip set and is housed in a 20 lead SSOP package ideally suited to cellular handset applications.

### Ordering Information

PART NUMBER	TEMP. RANGE (°C)	PACKAGE	PKG. NO.
HFA3767IA	-40 to 85	20 Ld SSOP	M20.15
HFA3767IA96	-40 to 85	Tape and Reel	

### Pinout

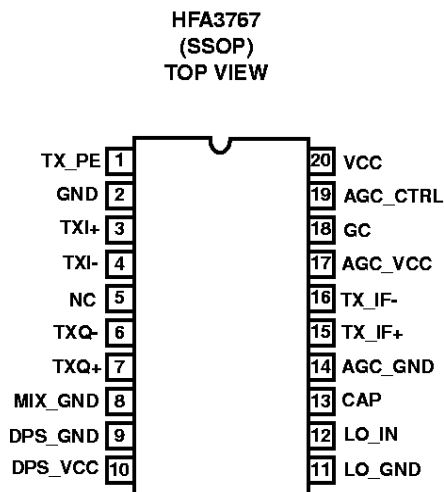

### Simplified Block Diagram

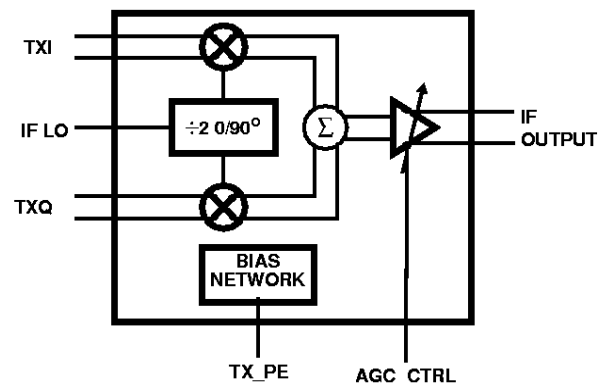

PRISM™ and the PRISM™ logo are trademarks of Harris Corporation

## HFA3767

### Pin Descriptions

Pin Number	NAME	DESCRIPTION
1	TX_PE	Power enable control input. HIGH for normal operation. LOW for power down.
2	GND	Bias and AGC control ground return.
3	TXI+	Positive I channel baseband input. Requires a 1.2VDC common mode bias voltage.
4	TXI-	Negative I channel baseband input. Requires a 1.2VDC common mode bias voltage.
5	NC	No connect pin. Tie to ground to improve isolation from I to Q channels.
6	TXQ-	Negative QI channel baseband input. Requires a 1.2VDC common mode bias voltage.
7	TXQ+	Positive Q channel baseband input. Requires a 1.2VDC common mode bias voltage.
8	MIX_GND	Quadrature Mixers ground return.
9	DPS_GND	Digital Phase shifter ground return.
10	DPS_VCC	Digital Phase Shifter Power Supply. Use high quality RF decoupling capacitors right at the pin.
11	LO_GND	Local Oscillator Input ground return.
12	LO_IN	Local Oscillator Current Input. Use a 50 $\Omega$ power to current converter. See applications diagram.
13	CAP	AGC Bias circuit filter capacitor. Typical value of 1000pF to 10000pF.
14	AGC_GND	AGC circuit ground return.
15	TX_IF+	Positive IF output port. Requires a DC return to VCC thru a choke or match inductor.
16	TX_IF-	Negative IF output port. Requires a DC return to VCC thru a choke or match inductor.
17	AGC_VCC	AGC circuit Power Supply. Use high quality RF decoupling capacitors right at the pin.
18	GCT	Gain and temperature compensation external resistor. See applications diagram.
19	AGC_CTRL	AGC control input. Require a 1% resistor divider at this input. See applications diagram.
20	VCC	Bias and AGC control Power Supply. Use high quality RF decoupling capacitors right at the pin.

# HFA3767

## Absolute Maximum Ratings $T_A = 25^\circ\text{C}$

Supply Voltage ..... -0.3V to +3.6V  
 Voltage on Any Other Pin ..... -0.3V to  $V_{CC} + 0.3V$

## Thermal Information

Thermal Resistance (Typical, Note 1)  $\theta_{JA}$  ( $^\circ\text{C}/\text{W}$ )  
 SSOP Package ..... 115  
 Maximum Junction Temperature (Plastic Package) .....  $150^\circ\text{C}$   
 Maximum Storage Temperature Range .....  $-65^\circ\text{C} \leq T_A \leq 150^\circ\text{C}$   
 Maximum Lead Temperature (Soldering 10s) .....  $300^\circ\text{C}$   
 (Lead Tips Only)

## Operating Conditions

Supply Voltage Range ..... 2.7V to 3.3V  
 Operating Temperature Range .....  $-40^\circ\text{C} \leq T_A \leq 85^\circ\text{C}$

*CAUTION: Stresses above those listed in "Absolute Maximum Ratings" may cause permanent damage to the device. This is a stress only rating and operation of the device at these or any other conditions above those indicated in the operational sections of this specification is not implied.*

### NOTE:

- $\theta_{JA}$  is measured with the component mounted on an evaluation PC board in free air.

## Electrical Specifications $V_{CC} = 2.7V$ to $3.3V$ , $LO\_IN = -10\text{dBm}$ @ 260MHz. Refer to Applications diagram

PARAMETER	TEST CONDITIONS	(Note 2) TEST LEVEL	TEMP ( $^\circ\text{C}$ )	MIN	TYP	MAX	UNITS
<b>CDMA MODE SPECIFICATIONS: I AND Q INPUTS @ 0.63Vpp Sinusoidal, 500KHz in Quadrature (SSB Output)</b>							
Output Power into 50 $\Omega$	$V_{agc} = 0.5V$ , Output from 400 to 50 $\Omega$ Differential to single end converter (0dB Attenuation)	A	25	-13.1	-12.7	-12.3	dBm
P1dBO/Output Power Ratio		A	Full	8	12.4	-	dB
Output Noise Floor		B	25	-	-142.3	-140	dBm/Hz
P1dBO/Output Power Ratio	AGC_CTRL set for 10dB of attenuation	B	Full	8	12.4	-	dB
Output Noise Floor		B	25	-	-144	-	dBm/Hz
P1dBO/Output Power Ratio	AGC_CTRL set for 20dB of attenuation	B	25	8	12.4	-	dB
Output Noise Floor		B	25	-	-148.5	-	dBm/Hz
P1dBO/Output Power Ratio	AGC_CTRL set for 30dB of attenuation	B	25	8	12.4	-	dB
Output Noise Floor		B	25	-	-153.4	-	dBm/Hz
P1dBO/Output Power Ratio	AGC_CTRL set for 40dB of attenuation	A	Full	8	12.4	-	dB
Output Noise Floor		B	25	-	-160	-	dBm/Hz
P1dBO/Output Power Ratio	AGC_CTRL set for 50dB of attenuation	A	Full	8	12.4	-	dB
Output Noise Floor		B	25	-	-163	-	dBm/Hz
P1dBO/Output Power Ratio	AGC_CTRL set for 70dB of attenuation	B	25	8	12.4	-	dB
Output Noise Floor		B	25	-	-165	-162	dBm/Hz
<b>FM MODE SPECIFICATIONS Q INPUT ONLY @ 0.44Vpp DC differential at Q input. Common mode voltage at I input</b>							
Output Power into 50 $\Omega$	$V_{agc} = 0.5V$ , Output from 400 to 50 $\Omega$ Differential to single end converter (0dB Attenuation)	A	Full	-10.2	-9.76	-9.3	dBm
P1dBO/Output Power Ratio		A	Full	7	10.2	-	dB
Output Noise Floor		B	25	-	-142.3	-140	dBm/Hz
<b>GENERAL SPECIFICATIONS: I AND Q INPUTS @ 0.63Vpp Sinusoidal, 500KHz in Quadrature (SSB Output)</b>							
AGC Gain Control Voltage		A	25	0.5	-	2.4	V
AGC Gain Control Sensitivity		B	25	-	50	-	dB/V

## HFA3767

### Electrical Specifications VCC = 2.7V to 3.3V, LO\_IN = -10dBm @ 260MHz. Refer to Applications diagram

PARAMETER	TEST CONDITIONS	(Note 2) TEST LEVEL	TEMP (°C)	MIN	TYP	MAX	UNITS
AGC Gain Control Input Impedance	Externally set	C	25	-	18	-	KΩ
AGC Switching Speed, Full Scale	To ±1dB Settling	B	25	-	-	10	μs
AGC Insertion Phase	20dB step	B	25	-	1.6	-	deg/dB
IF Frequency Range	Applications diagram	B	25	-	130	-	MHz
<b>GENERAL SPECIFICATIONS: I AND Q INPUTS @ 0.63Vpp Sinusoidal, 500KHz in Quadrature (SSB Output)</b>							
TX_IF single end equivalent series R	130MHz, IF+ or IF-	B	25	-	115	-	Ω
TX_IF single end equivalent series C	130MHz, IF+ or IF-	B	25	-	4.9	-	pF
Baseband Frequency Range		B	25	DC		1.0	MHz
LO Frequency Range	Applications diagram	A	25	-	260	-	MHz
Amplitude Balance (Note 3)	Deviation from ideal SSB characteristics	B	25	-0.5	-	+0.5	dB
Phase Balance (Note 3)	AGC_CTRL = 0.5V	B	25	-2	-	+2	Degrees
Single Sideband Suppression		A	Full	32	35		dBc
Carrier Suppression	(V <sub>agc</sub> = 0.5V) (0dB attenuation)	A	25	-30	-	-	dBc
	AGC_CTRL set for 20dB attenuation	A	25	-30	-	-	dBc
	AGC_CTRL set for 70dB attenuation	B	25	-29		-	dBc
LO Input Impedance	Single end	C	25	-	130	-	Ω
LO Drive Level	Applications diagram	A	25		-10		dBm
LO Drive Optimal Current Range		B	25	50	200	300	μArms
Baseband Differential Input Impedance		C	25	2K	-	-	Ω
VCM Common mode Input Voltage	Into I+, I-, Q+ and Q-	A	Full	1.14	1.20	1.26	V
<b>POWER SUPPLY AND LOGIC SPECIFICATIONS</b>							
Supply Voltage Range		B	25	2.7	-	3.3	V
Supply Current @ 3.3V	AGC_CTRL = 0.5V	A	Full	-	-	40	mA
	AGC_CTRL = 2.4V	A	Full	-	-	25	mA
Power Down Supply Current	TX_PE = Low	A	25	-	-	100	μA
Power Down Speed		B	Full	-	-	10	μs
TX_PE V <sub>IL</sub>		A	Full	-	-	0.8	V
TX_PE V <sub>IH</sub>		A	Full	2.0	-	-	V
TX_PE Input Bias Current @ VCC = 3.3V	PE = 2.0V	A	Full	-50	-	+50	μA
	PE = 0.66V, 2.7VCC	A	Full	-50	-	+50	μA

**NOTE:**

2. A = Production Tested, B = Based on Characterization, C = By Design

3. I leading Q produces a positive frequency offset from the carrier (USB). Test guaranteed by sideband suppression.

