

REVISIONS				
P	LTN	DESCRIPTION	DATE	APP'D
A1		REVISED PER ECO-09-025699	12DEC09	KK AEG
B		REVISED PER ECO-21-000623	28JAN2021	AK SZ

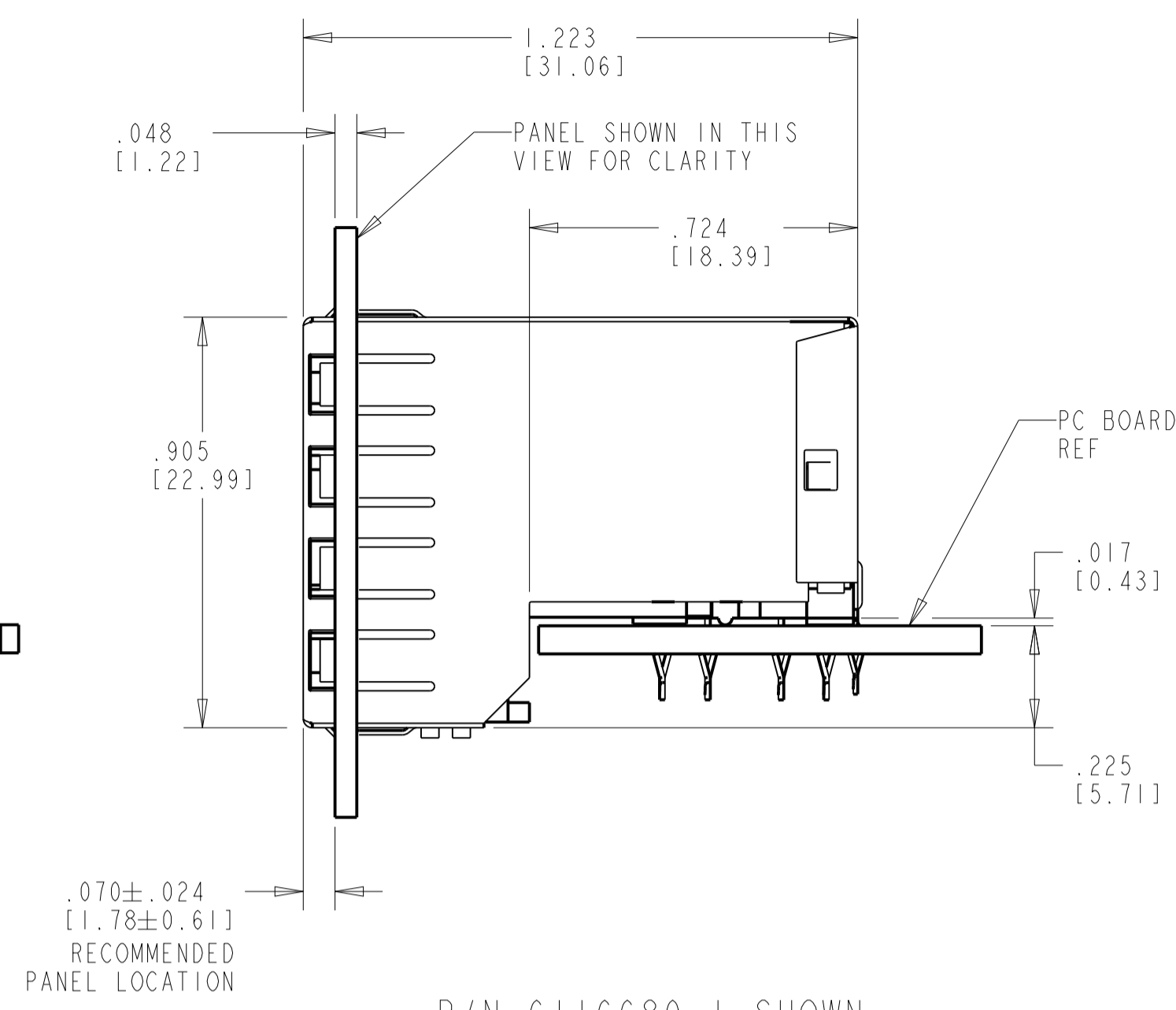

- △ HOUSING: PBT POLYESTER, BLACK, UL 94V-0.
- TERMINALS: 0.30 THICK PHOS BRONZE PLATED WITH 1.27µm MINIMUM THICK HARD GOLD IN LOCALIZED AREA AND 2µm MINIMUM THICK MATTE TIN IN ACTION PIN COMPLIANT PIN TERMINAL AREA OVER 1.27µm MINIMUM THICK NICKEL UNDERPLATE.
- SHIELD: 0.25 THICK COPPER ALLOY PLATED WITH 1.27µm MINIMUM NICKEL.
- GROUND CLIPS: 0.25 THICK COPPER ALLOY PLATED WITH 2.03µm MINIMUM MATTE TIN OVER 1.27µm MINIMUM NICKEL.
- 2. JACK CAVITY CONFORMS TO FCC RULES AND REGULATIONS, PART 68 SUBPART F.
- 3. ALL DIMENSIONS ARE NOMINAL UNLESS OTHERWISE SPECIFIED.
- △4 DRILLED HOLE DIA = .040±.001.  
COPPER THICKNESS = .001-.003.  
TIN THICKNESS = .0003 MIN.
- △5 DATUMS AND BASIC DIMENSIONS ESTABLISHED BY CUSTOMER.
- △6 THESE FOUR SIDE PCB ACTION PIN GROUNDS AND CORRESPONDING PCB HOLES ARE REQUIRED ONLY ON 6116689-3.
- △ DATE CODE LOCATED ON REAR OF PART APPROXIMATELY AS SHOWN.
- △8 OBSOLETE PARTS: OBSOLETE CIS STREAMLINING PER D.RENAUD/D.SINISI.

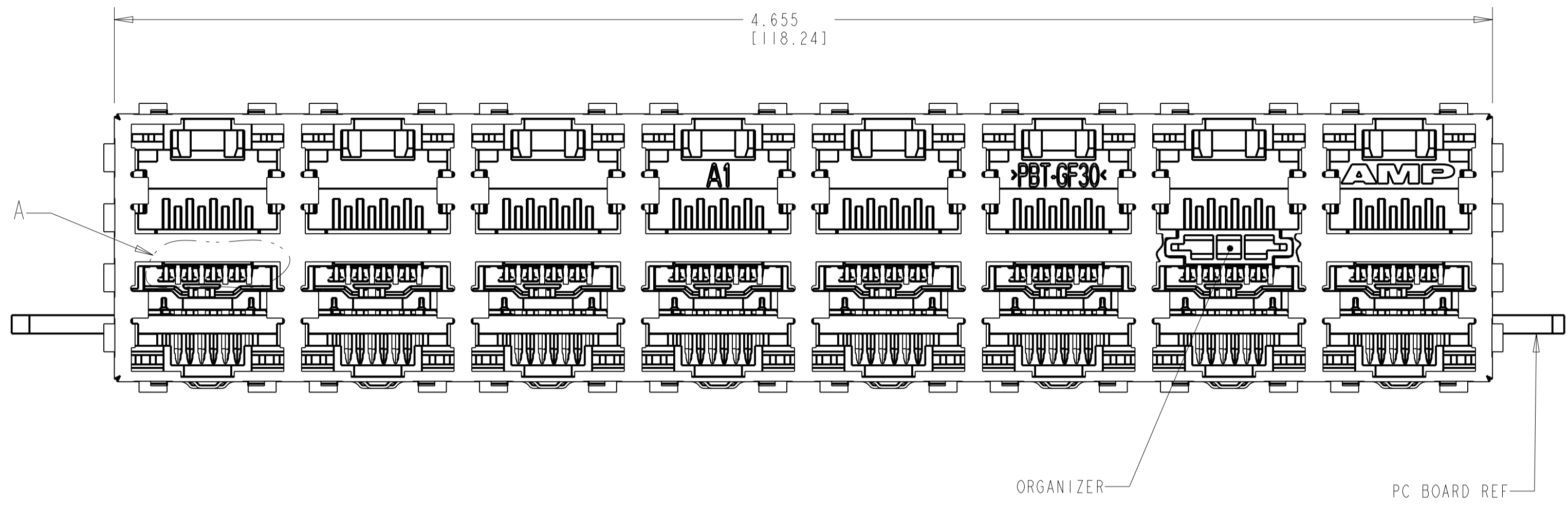
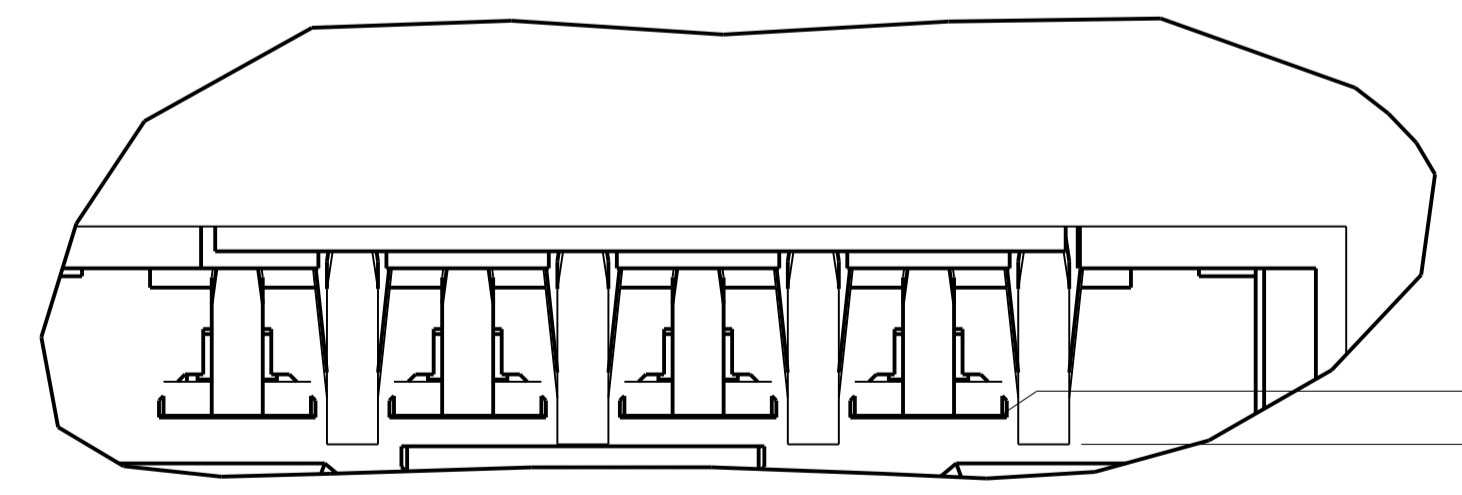
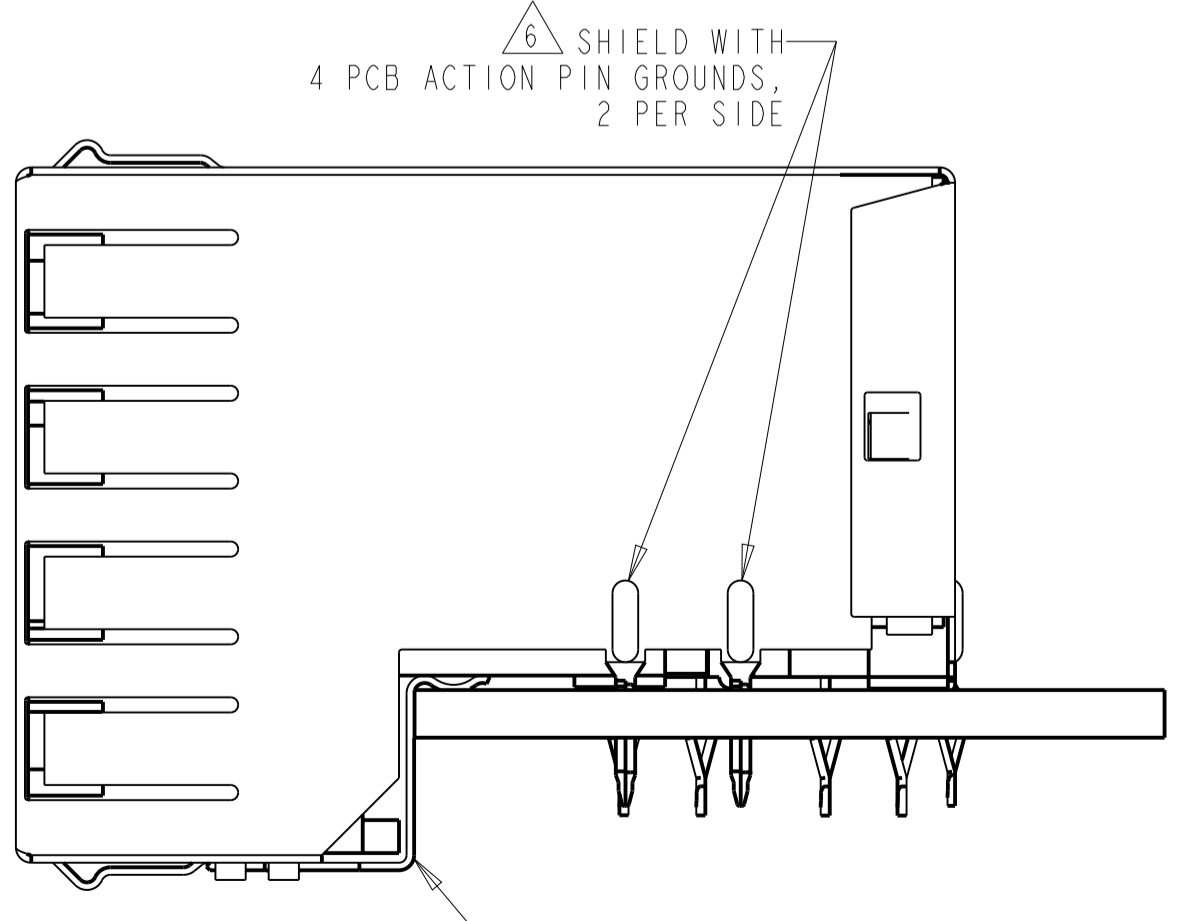
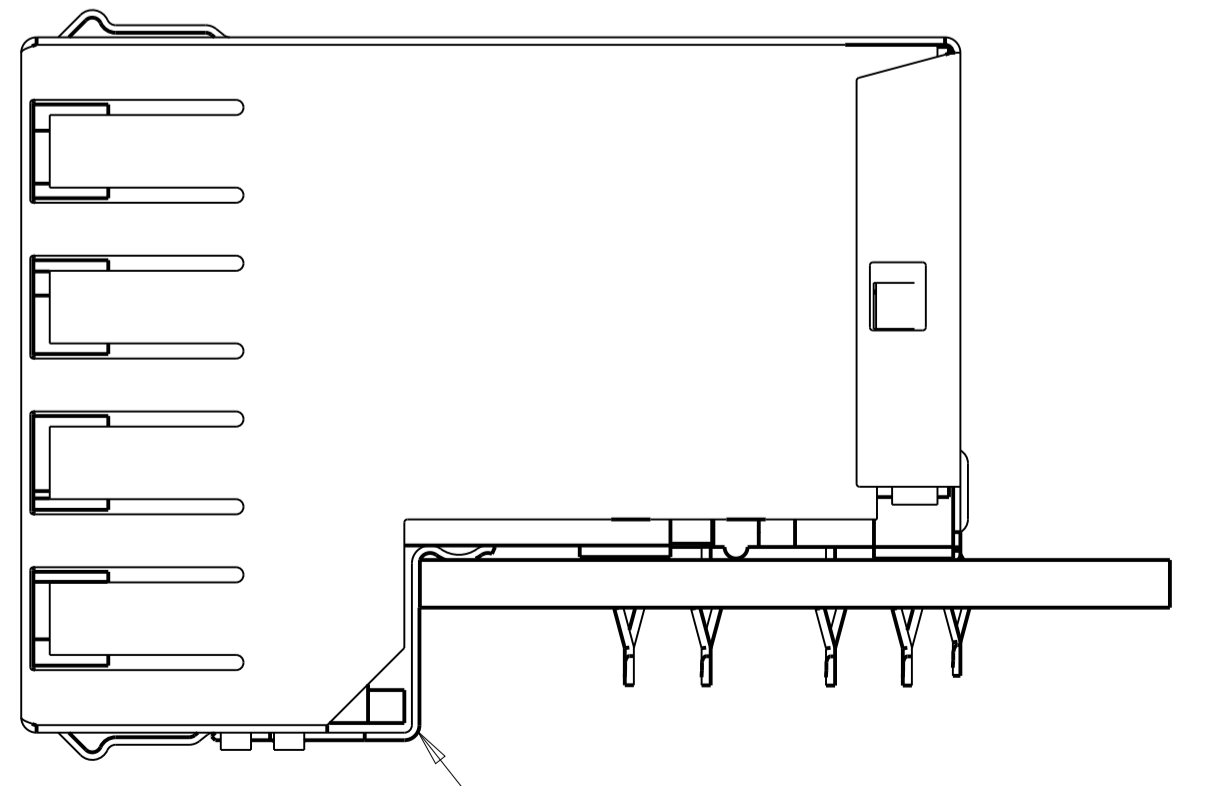
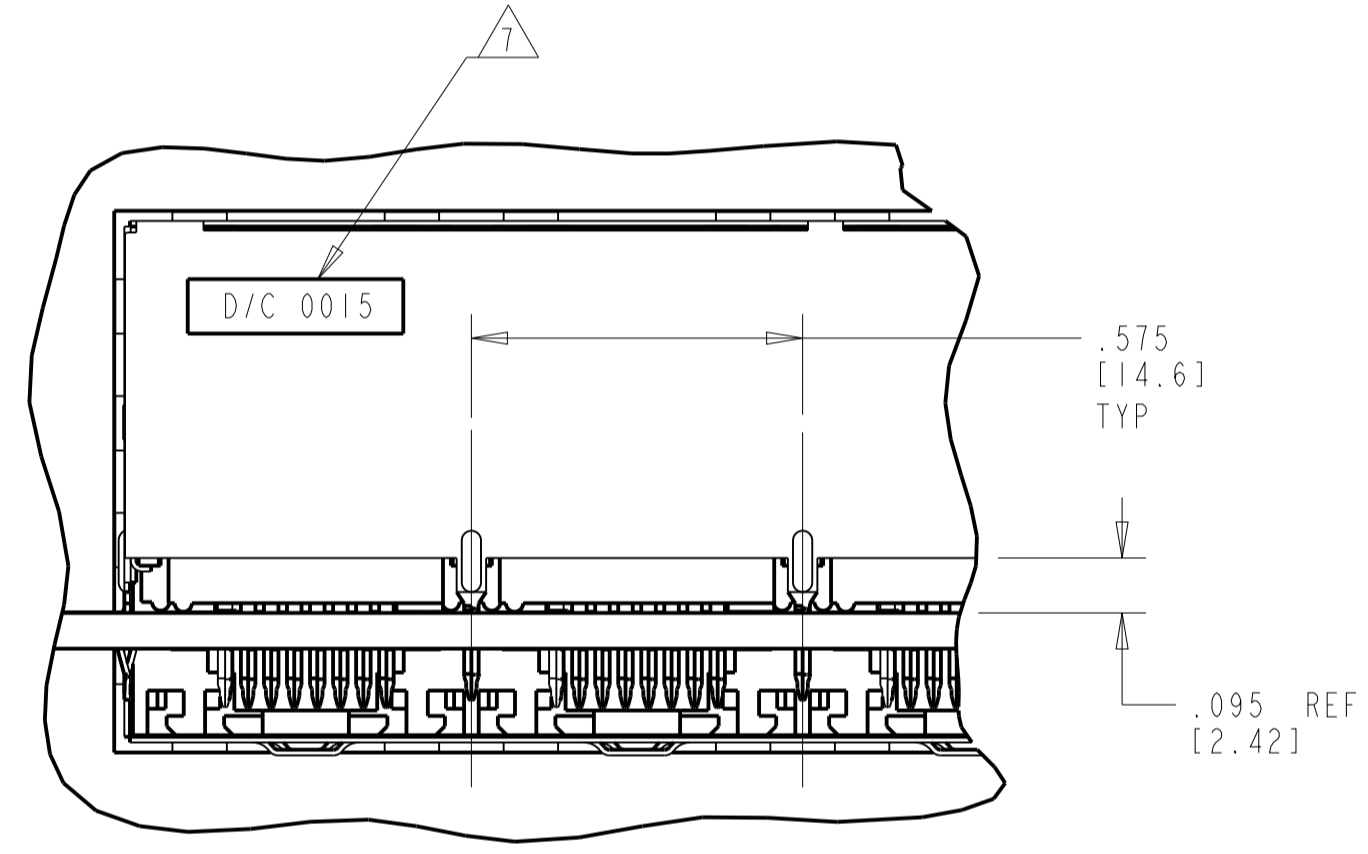
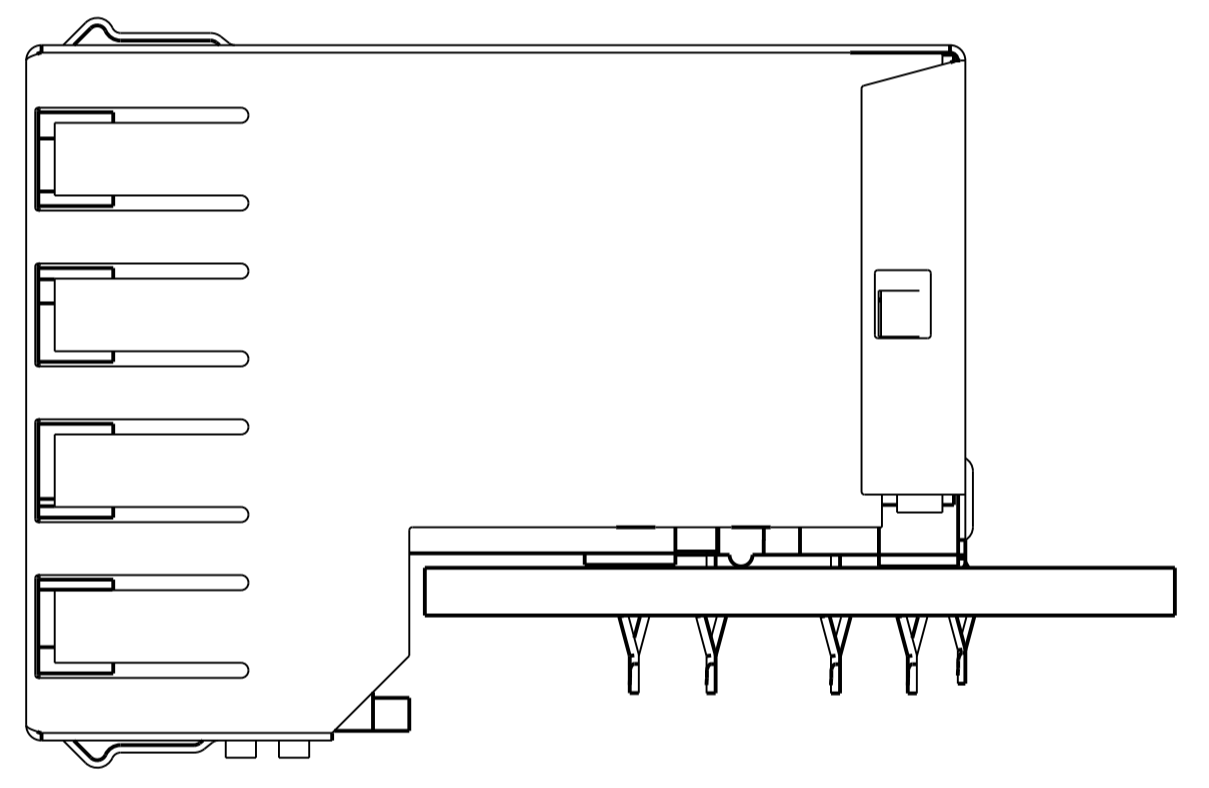

△8 OBSOLETE	8	NONE	6116689-4
	8	△6 4	6116689-3
	NONE	NONE	6116689-1
	GROUND CLIPS	SIDE PCB ACTION PIN GNDS	PART NUMBER

THIS DRAWING IS A CONTROLLED DOCUMENT.

TE Connectivity

NAME: STACKED MODULAR JACK ASSEMBLY, 2 X 8, 8 POSITION, SHIELDED, PANEL GROUND, OFFSET, CAT 5

SIZE: A1

SCALE: 3:1

SHEET: 1 OF 2

REV: B

REVISIONS				
P.	LTN	DESCRIPTION	DATE	APVD
-	-	SEE SHEET 1	-	-

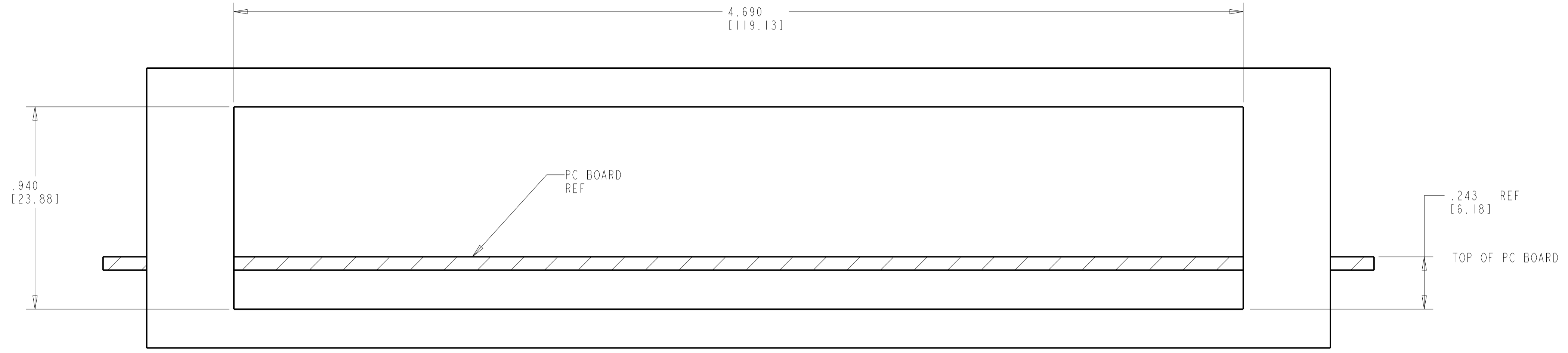

RECOMMENDED PANEL CUT-OUT

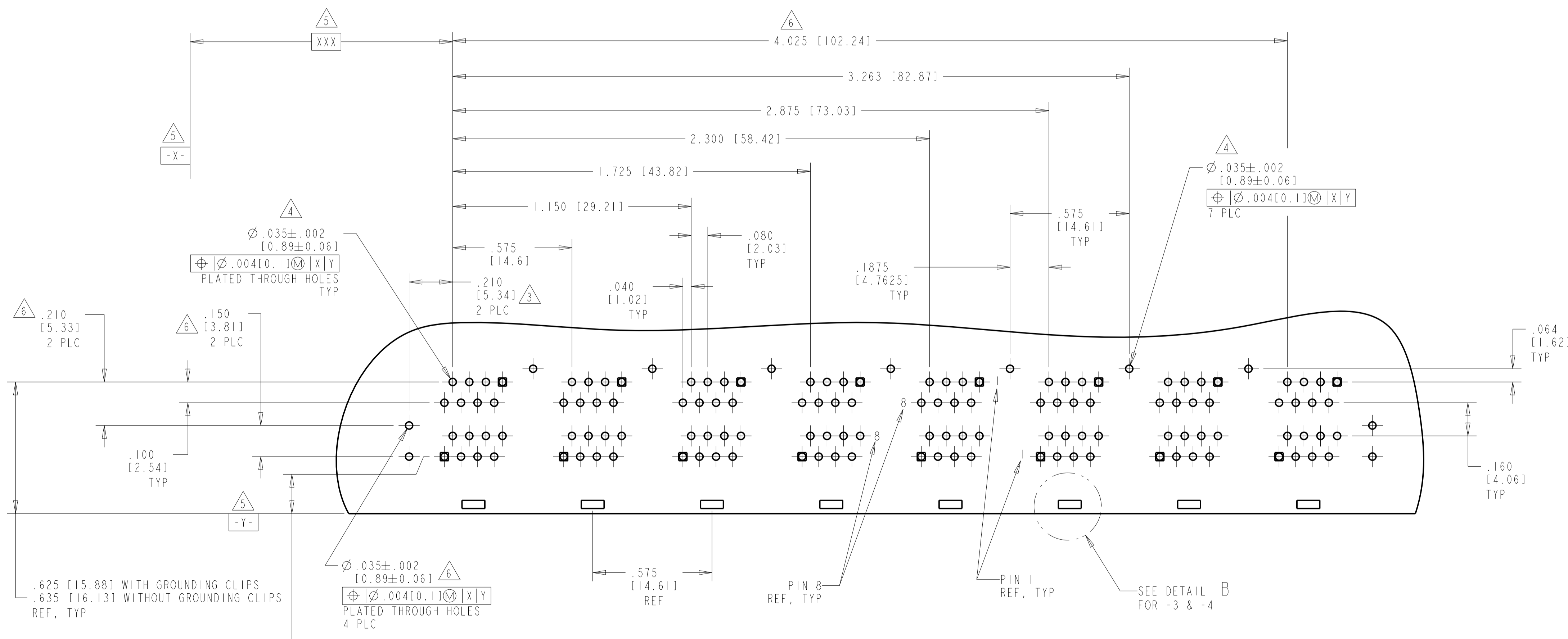

PC BOARD LAYOUT  
(COMPONENT SIDE)

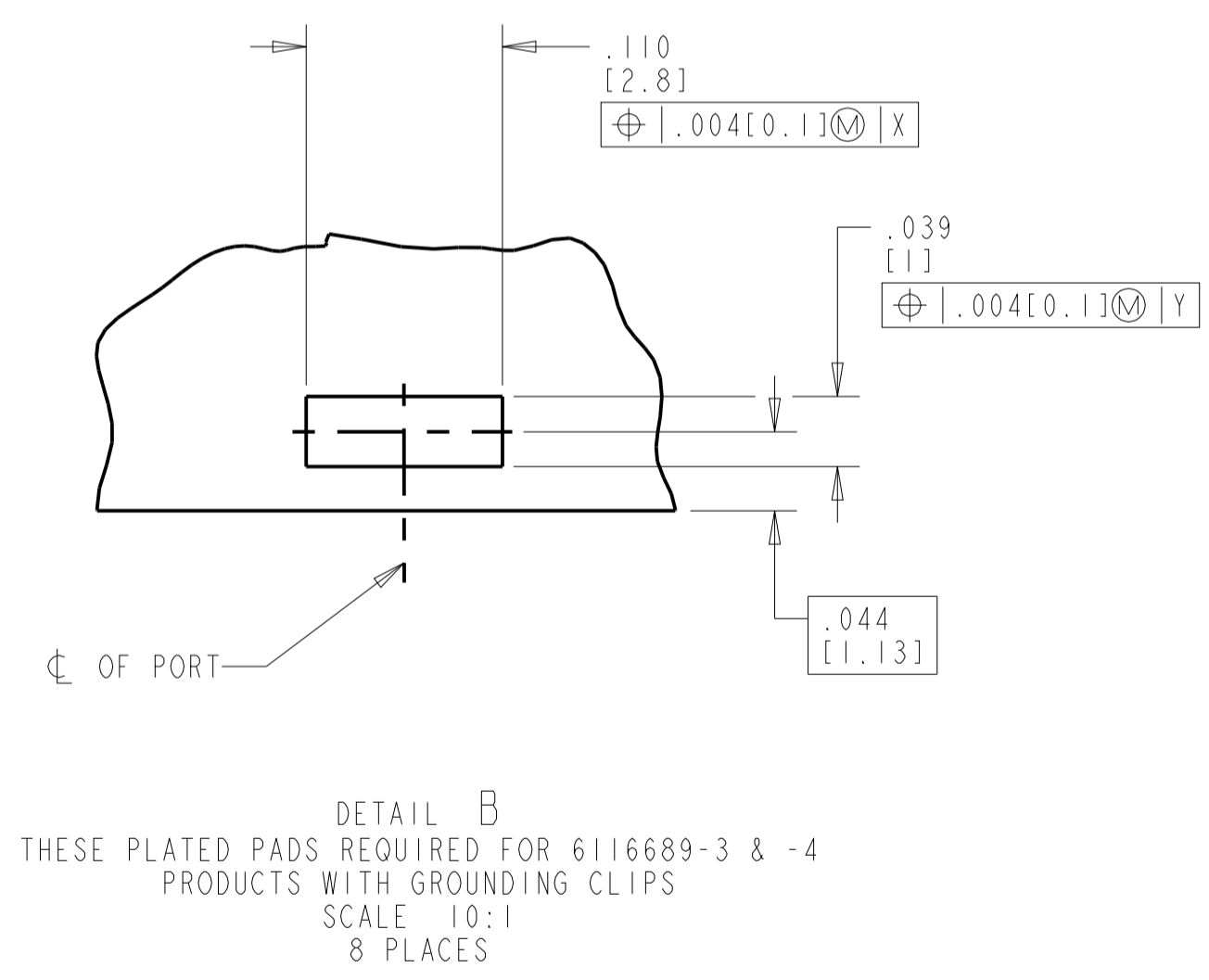

DETAIL B  
THESE PLATED PADS REQUIRED FOR 6116689-3 & -4  
PRODUCTS WITH GROUNDING CLIPS  
SCALE 10:1  
8 PLACES

THIS DRAWING IS A CONTROLLED DOCUMENT.		DWN L. VARELA - DOCKS 23 JUN 2005 CHM J. WESTMAN 23 JUN 2005 APVD S. FLICKINGER 23 JUN 2005	TE Connectivity
DIMENSIONS: INCHES [mm]	TOLERANCES UNLESS OTHERWISE SPECIFIED: 0 PLC ± 1 PLC ± 2 PLC ± 3 PLC ± 4 PLC ±0.25 [0.010] ANGLES ±	NAME STACKED MODULAR JACK ASSEMBLY, 2 X 8, 8 POSITION, SHIELDED, PANEL GROUND, OFFSET, CAT 5 SIZE CAGE CODE DRAWING NO. RESTRICTED TO A 00779 C=6116689	
MATERIAL	FINISH	WEIGHT	CUSTOMER DRAWING SCALE 3:1 SHEET 2 OF 2 REV B