

THIS DRAWING IS UNPUBLISHED. RELEASED FOR PUBLICATION
 © COPYRIGHT - By - ALL RIGHTS RESERVED.

REVISIONS					
P	LTR	DESCRIPTION	DATE	DWN	APVD
V2		REVISED PER ECO-16-004223	19JUL2016	NK	MZ

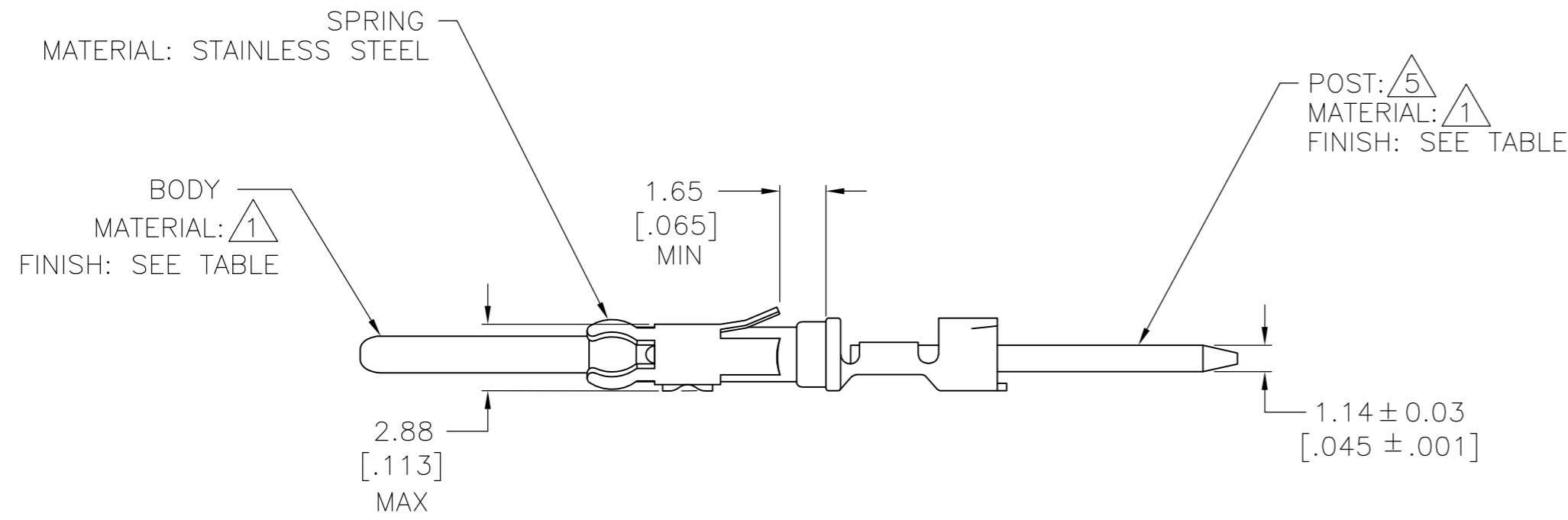
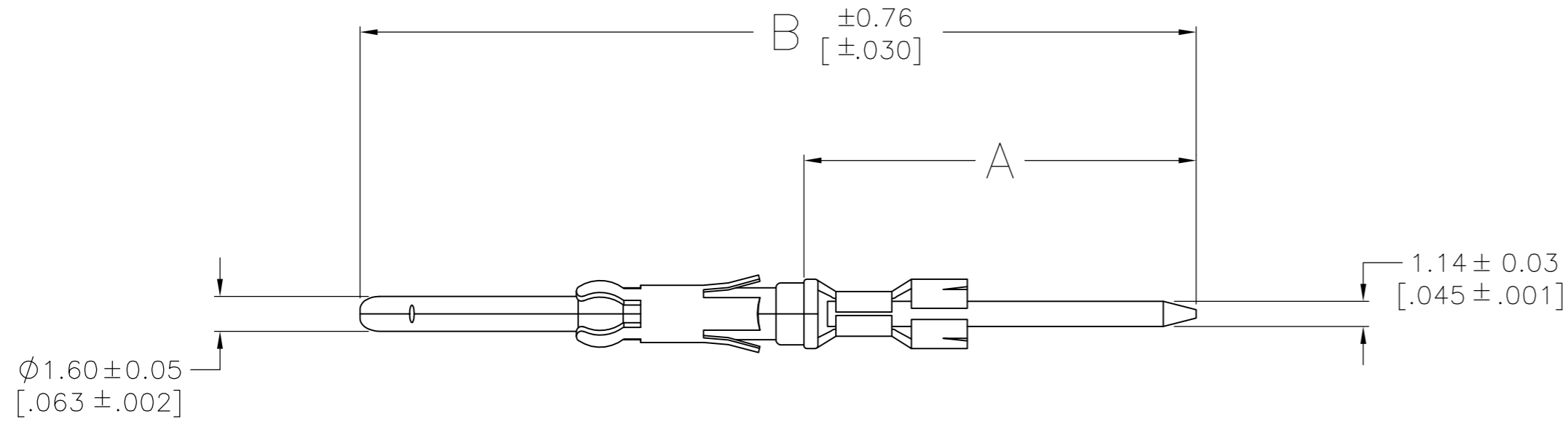

- 1 BRASS PER ASTM B-36.
- 2 2.54um[.000100] MIN TIN-LEAD OVER 1.27um[.000050] MIN NICKEL.
- 3 SELECTIVELY PLATED 0.76um[.000030] MIN GOLD, FOR A DISTANCE OF 5.08[.200] FROM MATING END, GOLD FLASH ON REMAINDER, ALL OVER 1.27um[.000050] MIN NICKEL.
- 4 GOLD PLATING NOT TO APPEAR ON INSULATION SUPPORT STABILIZER.
- 5 POST WILL ACCEPT (SEE TABLE) TERMINATIONS.
- 6 .000100 MIN TIN OVER .000050 NICKEL. (POST).
- 7 OBSOLETE PARTS: OBSOLETE CIS STREAMLINING PER D.RENAUD/D.SINISI.

OBSOLETE		3	SPECIAL	35.03 [1.379]	14.86 [.585]	1-66471-9
		3	1	37.97 [1.495]	17.81 [.701]	1-66471-8
	6	6	3	49.89 [1.964]	29.74 [1.171]	1-66471-7
OBSOLETE		6	1	37.97 [1.495]	17.81 [.701]	1-66471-6
		3	3	49.89 [1.964]	29.74 [1.171]	1-66471-5
		3	SPECIAL	35.03 [1.379]	14.86 [.585]	7 1-66471-4
OBSOLETE		2	SPECIAL	40.79 [1.606]	20.65 [.813]	1-66471-0
		3	3	49.89 [1.964]	29.74 [1.171]	66471-9
		3	1	37.97 [1.495]	17.81 [.701]	66471-7
		2	3	49.89 [1.964]	29.74 [1.171]	66471-3
		2	1	37.97 [1.495]	17.81 [.701]	66471-1
	POST FINISH	BODY FINISH	NO OF TERM	B	A	PART NUMBER

THIS DRAWING IS A CONTROLLED DOCUMENT.		DWN C.REIFSNYDER 07 JUN 96	TE Connectivity			
DIMENSIONS: mm [INCHES]		CHK R.STONE 12 JUL 96				
TOLERANCES UNLESS OTHERWISE SPECIFIED:		APVD G.A.STEINHAUER 23 JUL 96	NAME PIN CONTACT, CRIMPED, .062 DIA, .045 x .045 POST,			
0 PLC ± - 1 PLC ± - 2 PLC ± 0.25[.010] 3 PLC ± - 4 PLC ± - ANGLES ± - FINISH SEE CALLOUTS		PRODUCT SPEC APPLICATION SPEC	SIZE A2	CAGE CODE 00779	DRAWING NO 66471	RESTRICTED TO -
MATERIAL SEE CALLOUTS		WEIGHT -	SCALE 4:1		SHEET 1 of 1	REV V2
CUSTOMER DRAWING						