

RS-232 TRANSCEIVER WITH SPLIT SUPPLY PIN FOR LOGIC SIDE

 Check for Samples: [TRS3386E](#)

FEATURES

- V_L Pin for Compatibility With Mixed-Voltage Systems Down to 2.5 V on Logic Side
- Enhanced ESD Protection on RIN Inputs and DOUT Outputs
 - ± 15 -kV Human-Body Model
 - ± 15 -kV IEC 61000-4-2, Air-Gap Discharge
 - ± 8 -kV IEC 61000-4-2, Contact Discharge
- Low 300- μ A Supply Current
- Specified 250-kbps Data Rate
- 1- μ A Low-Power Shutdown
- Meets EIA/TIA-232 Specifications Down to 3 V
- Designed to be Interchangeable With Industry Standard '3386 Devices

APPLICATIONS

- Hand-Held Equipment
- PDAs
- Cell Phones
- Battery-Powered Equipment
- Data Cables

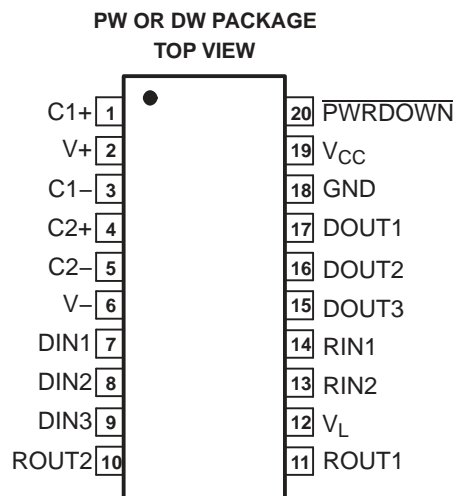

DESCRIPTION/ORDERING INFORMATION

The TRS3386E is a three-driver and two-receiver RS-232 interface device, with split supply pins for mixed-signal operations. All RS-232 inputs and outputs are protected to ± 15 kV using the IEC 61000-4-2 Air-Gap Discharge method, ± 8 kV using the IEC 61000-4-2 Contact Discharge method, and ± 15 kV using the Human-Body Model.

The charge pump requires only four small 0.1- μ F capacitors for operation from a 3.3-V supply. The TRS3386E is capable of running at data rates up to 250 kbps, while maintaining RS-232-compliant output levels.

The TRS3386E has a unique V_L pin that allows operation in mixed-logic voltage systems. Both driver in (DIN) and receiver out (ROUT) logic levels are pin programmable through the V_L pin. The TRS3386E is available in a space-saving thin shrink small-outline package (TSSOP).

ORDERING INFORMATION

T _A	PACKAGE ⁽¹⁾ (2)	ORDERABLE PART NUMBER	TOP-SIDE MARKING
0°C to 70°C	TSSOP – PW	TRS3386ECPWR	RV86EC
	SOIC – DW	TRS3386ECDWR	TRS3386EC
–40°C to 85°C	TSSOP – PW	TRS3386EIPWR	RV86EI
	SOIC – DW	TRS3386EIDWR	TRS3386EI

(1) Package drawings, thermal data, and symbolization are available at www.ti.com/packaging.

(2) For the most current package and ordering information, see the Package Option Addendum at the end of this document, or see the TI website at www.ti.com.



Please be aware that an important notice concerning availability, standard warranty, and use in critical applications of Texas Instruments semiconductor products and disclaimers thereto appears at the end of this data sheet.

Table 1. TRUTH TABLE (SHUTDOWN FUNCTION)

$\overline{\text{PWRDWN}}$	DRIVER OUTPUTS	RECEIVER OUTPUTS	CHARGE PUMP
L	High-Z	High-Z	Inactive
H	Active	Active	Active

FUNCTIONAL BLOCK DIAGRAM

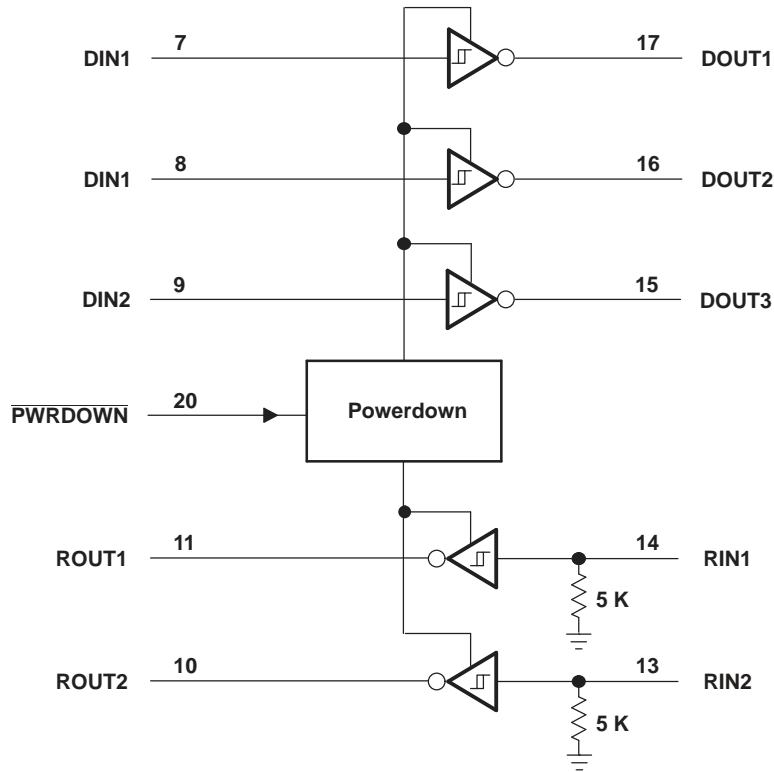

TERMINAL FUNCTIONS

TERMINAL		DESCRIPTION
NAME	NO.	
C1+	1	Positive terminal of the voltage-doubler charge-pump capacitor
V+	2	5.5-V supply generated by the charge pump
C1–	3	Negative terminal of the voltage-doubler charge-pump capacitor
C2+	4	Positive terminal of the inverting charge-pump capacitor
C2–	5	Negative terminal of the inverting charge-pump capacitor
V–	6	–5.5-V supply generated by the charge pump
DIN1	7	Driver inputs
DIN2	8	
DIN3	9	
ROUT2	10	Receiver outputs. Swing between 0 and V _L .
ROUT1	11	
V _L	12	Logic-level supply. All CMOS inputs and outputs are referenced to this supply.
RIN2	13	RS-232 receiver inputs
RIN1	14	
DOUT3	15	RS-232 driver outputs
DOUT2	16	
DOUT1	17	
GND	18	Ground
V _{CC}	19	3-V to 5.5-V supply voltage
$\overline{\text{PWRDWN}}$	20	Powerdown input L = Powerdown H = Normal operation

Absolute Maximum Ratings⁽¹⁾

over operating free-air temperature range (unless otherwise noted)

		MIN	MAX	UNIT
V _{CC} to GND		–0.3	6	V
V _L to GND		–0.3	V _{CC} + 0.3	V
V+ to GND		–0.3	7	V
V– to GND		0.3	–7	V
V+ + V– ⁽²⁾			13	V
V _I	Input voltage	DIN, $\overline{\text{PWRDWN}}$ to GND		V
		RIN to GND		
V _O	Output voltage	DOUT to GND		V
		ROUT		
Short-circuit duration DOUT to GND		Continuous		
Continuous power dissipation		T _A = 70°C, 20-pin TSSOP (derate 7 mW/°C above 70°C)		mW
T _J	Junction temperature		150	°C
T _{stg}	Storage temperature range	–65	150	°C
	Lead temperature (soldering, 10 s)		300	°C

- (1) Stresses beyond those listed under “absolute maximum ratings” may cause permanent damage to the device. These are stress ratings only, and functional operation of the device at these or any other conditions beyond those indicated in the operational sections of the specifications is not implied. Exposure to absolute maximum rating conditions for extended periods may affect device reliability.
- (2) V+ and V– can have maximum magnitudes of 7 V, but their absolute difference cannot exceed 13 V.

Recommended Operating Conditions

			MIN	MAX	UNIT
V _{CC}	Supply voltage		3	5.5	V
V _L	Supply voltage		2.25	V _{CC}	V
Input logic threshold low	DIN, $\overline{\text{PWRDWN}}$	V _L = 3 V or 5.5 V		0.8	V
		V _L = 2.3 V		0.6	
Input logic threshold high	DIN, $\overline{\text{PWRDWN}}$	V _L = 5.5 V	2.4		V
		V _L = 3 V	2.0		
		V _L = 2.7 V	1.4		
Operating temperature		TRS3386ECPWR	0	70	°C
		TRS3386EIPWR	-40	85	
Receiver input voltage			-25	25	V

Electrical Characteristics

over operating free-air temperature range, V_{CC} = V_L = 3 V to 5.5 V, C1–C4 = 0.1 μF (tested at 3.3 V ± 10%), C1 = 0.047 μF, C2–C4 = 0.33 μF (tested at 5 V ± 10%) (unless otherwise noted)

PARAMETER	TEST CONDITIONS	MIN	TYP ⁽¹⁾	MAX	UNIT
DC Characteristics (V_{CC} = 3.3 V or 5 V, T_A = 25°C)					
Powerdown supply current	$\overline{\text{PWRDWN}}$ = GND, All inputs at V _{CC} or GND		1	10	μA
Supply current	$\overline{\text{PWRDWN}}$ = V _{CC} , No load		0.3	1	mA

(1) Typical values are at V_{CC} = V_L = 3.3 V, T_A = 25°C.

ESD Protection

PARAMETER	TEST CONDITIONS	TYP	UNIT
RIN, DOUT	Human-Body Model	±15	kV
	IEC 61000-4-2 Air-Gap Discharge	±15	
	IEC 61000-4-2 Contact Discharge	±8	

RECEIVER SECTION

Electrical Characteristics

over operating free-air temperature range, $V_{CC} = V_L = 3\text{ V to }5.5\text{ V}$, $C1\text{--}C4 = 0.1\text{ }\mu\text{F}$ (tested at $3.3\text{ V} \pm 10\%$), $C1 = 0.047\text{ }\mu\text{F}$, $C2\text{--}C4 = 0.33\text{ }\mu\text{F}$ (tested at $5\text{ V} \pm 10\%$), $T_A = T_{MIN}$ to T_{MAX} (unless otherwise noted)

PARAMETER		TEST CONDITIONS	MIN	TYP ⁽¹⁾	MAX	UNIT	
I_{off}	Output leakage current	R_{OUT} , receivers disabled		± 0.05	± 10	μA	
V_{OL}	Output voltage low	$I_{OUT} = 1.6\text{ mA}$			0.4	V	
V_{OH}	Output voltage high	$I_{OUT} = -1\text{ mA}$	$V_L - 0.6$	$V_L - 0.1$		V	
V_{IT-}	Input threshold low	$T_A = 25^\circ\text{C}$	$V_L = 5\text{ V}$	0.8	1.2	V	
			$V_L = 3.3\text{ V}$	0.6	1.5		
V_{IT+}	Input threshold high	$T_A = 25^\circ\text{C}$	$V_L = 5\text{ V}$		1.8	2.4	V
			$V_L = 3.3\text{ V}$		1.5	2.4	
V_{hys}	Input hysteresis			0.5		V	
	Input resistance	$T_A = 25^\circ\text{C}$	3	5	7	k Ω	

(1) Typical values are at $V_{CC} = V_L = 3.3\text{ V}$, $T_A = 25^\circ\text{C}$

Switching Characteristics

over operating free-air temperature range, $V_{CC} = V_L = 3\text{ V to }5.5\text{ V}$, $C1\text{--}C4 = 0.1\text{ }\mu\text{F}$ (tested at $3.3\text{ V} \pm 10\%$), $C1 = 0.047\text{ }\mu\text{F}$, $C2\text{--}C4 = 0.33\text{ }\mu\text{F}$ (tested at $5\text{ V} \pm 10\%$), $T_A = T_{MIN}$ to T_{MAX} (unless otherwise noted)

PARAMETER		TEST CONDITIONS	TYP ⁽¹⁾	UNIT
t_{PHL}	Receiver propagation delay	Receiver input to receiver output, $C_L = 150\text{ pF}$	0.15	μs
t_{PLH}			0.15	
$t_{PHL} - t_{PLH}$	Receiver skew		50	ns
t_{en}	Receiver output enable time	From $\overline{\text{PWRDWN}}$	200	ns
t_{dis}	Receiver output disable time	From $\overline{\text{PWRDWN}}$	200	ns

(1) Typical values are at $V_{CC} = V_L = 3.3\text{ V}$, $T_A = 25^\circ\text{C}$.

DRIVER SECTION

Electrical Characteristics

over operating free-air temperature range, $V_{CC} = V_L = 3\text{ V}$ to 5.5 V , $C1-C4 = 0.1\ \mu\text{F}$ (tested at $3.3\text{ V} \pm 10\%$), $C1 = 0.047\ \mu\text{F}$, $C2-C4 = 0.33\ \mu\text{F}$ (tested at $5\text{ V} \pm 10\%$), $T_A = T_{MIN}$ to T_{MAX} (unless otherwise noted)

PARAMETER	TEST CONDITIONS	MIN	TYP ⁽¹⁾	MAX	UNIT
V_{OH} Output voltage swing	All driver outputs loaded with $3\text{ k}\Omega$ to ground	± 5	± 5.4		V
r_o Output resistance	$V_{CC} = V_+ = V_- = 0$, Driver output = $\pm 2\text{ V}$	300	10M		Ω
I_{OS} Output short-circuit current	$V_{T_OUT} = 0$			± 60	mA
I_{OZ} Output leakage current	$V_{T_OUT} = \pm 12\text{ V}$, Driver disabled, $V_{CC} = 0$ or 3 V to 5.5 V			± 25	μA
Driver input hysteresis				0.5	V
Input leakage current	DIN, $\overline{\text{PWRDWN}}$		± 0.01	± 1	μA

(1) Typical values are at $V_{CC} = V_L = 3.3\text{ V}$, $T_A = 25^\circ\text{C}$

Timing Requirements

over operating free-air temperature range, $V_{CC} = V_L = 3\text{ V}$ to 5.5 V , $C1-C4 = 0.1\ \mu\text{F}$ (tested at $3.3\text{ V} \pm 10\%$), $C1 = 0.047\ \mu\text{F}$, $C2-C4 = 0.33\ \mu\text{F}$ (tested at $5\text{ V} \pm 10\%$), $T_A = T_{MIN}$ to T_{MAX} (unless otherwise noted)

PARAMETER	TEST CONDITIONS	MIN	TYP ⁽¹⁾	MAX	UNIT
Maximum data rate	$R_L = 3\text{ k}\Omega$, $C_L = 1000\text{ pF}$, One driver switching	250			kbps
Time-to-exit powerdown	$ V_{T_OUT} > 3.7\text{ V}$		100		μs
$ t_{PHL} - t_{PLH} $ Driver skew ⁽²⁾			100		ns
Transition-region slew rate	$V_{CC} = 3.3\text{ V}$, $T_A = 25^\circ\text{C}$, $R_L = 3\text{ k}\Omega$ to $7\text{ k}\Omega$, Measured from 3 V to -3 V or -3 V to 3 V	$C_L = 150\text{ pF}$ to 1000 pF	6	30	V/ μs
		$C_L = 150\text{ pF}$ to 2500 pF	4	30	

(1) Typical values are at $V_{CC} = V_L = 3.3\text{ V}$, $T_A = 25^\circ\text{C}$.

(2) Driver skew is measured at the driver zero crosspoint.

ESD Protection

PARAMETER	TEST CONDITIONS	TYP	UNIT
RIN, DOUT	Human-Body Model	± 15	kV
	IEC 61000-4-2 Air-Gap Discharge	± 15	
	IEC 61000-4-2 Contact Discharge	± 8	

APPLICATION INFORMATION

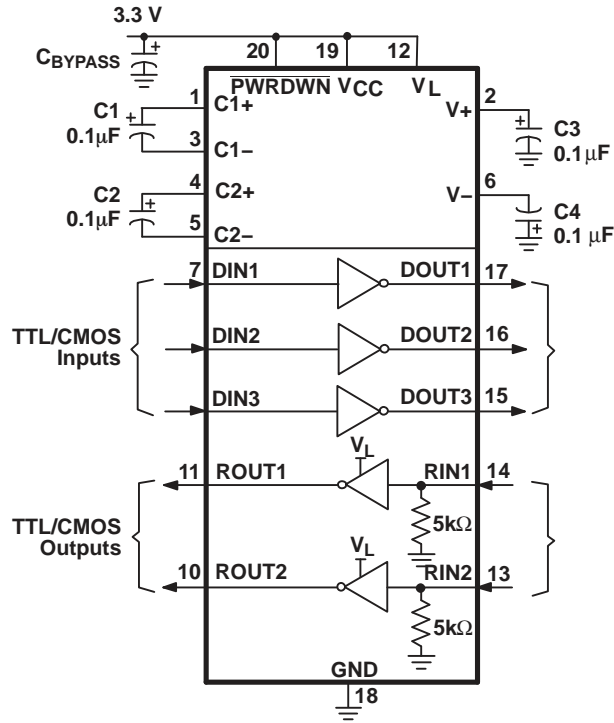

PARAMETER MEASUREMENT INFORMATION

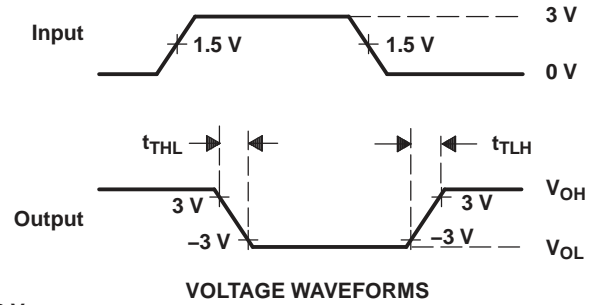
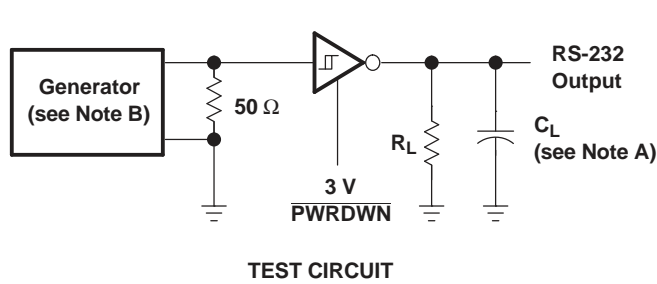

$$SR(tr) = \frac{6\text{ V}}{t_{THL} \text{ or } t_{TLH}}$$

- NOTES: A. C_L includes probe and jig capacitance.
 B. The pulse generator has the following characteristics: PRR = 250 kbit/s, Z_O = 50 Ω, 50% duty cycle, t_r ≤ 10 ns, t_f ≤ 10 ns.

Figure 1. Driver Slew Rate

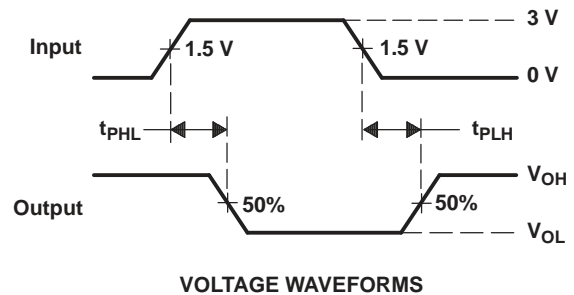
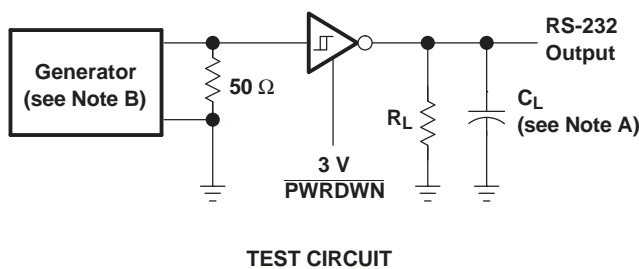

- NOTES: A. C_L includes probe and jig capacitance.
 B. The pulse generator has the following characteristics: PRR = 250 kbit/s, Z_O = 50 Ω, 50% duty cycle, t_r ≤ 10 ns, t_f ≤ 10 ns.

Figure 2. Driver Pulse Skew

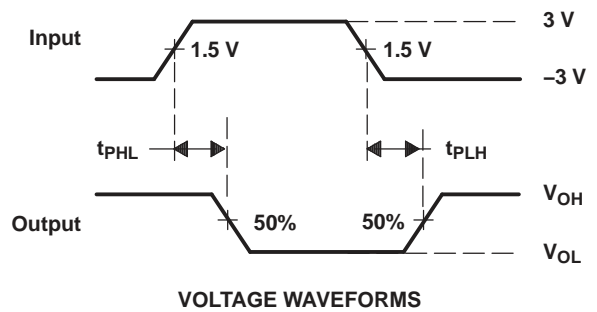
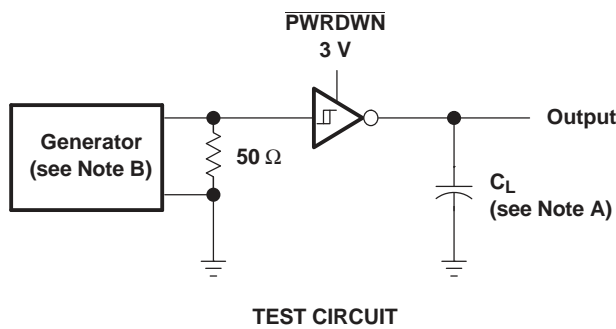

- NOTES: A. C_L includes probe and jig capacitance.
 B. The pulse generator has the following characteristics: Z_O = 50 Ω, 50% duty cycle, t_r ≤ 10 ns, t_f ≤ 10 ns.

Figure 3. Receiver Propagation Delay Times

PARAMETER MEASUREMENT INFORMATION (Continued)

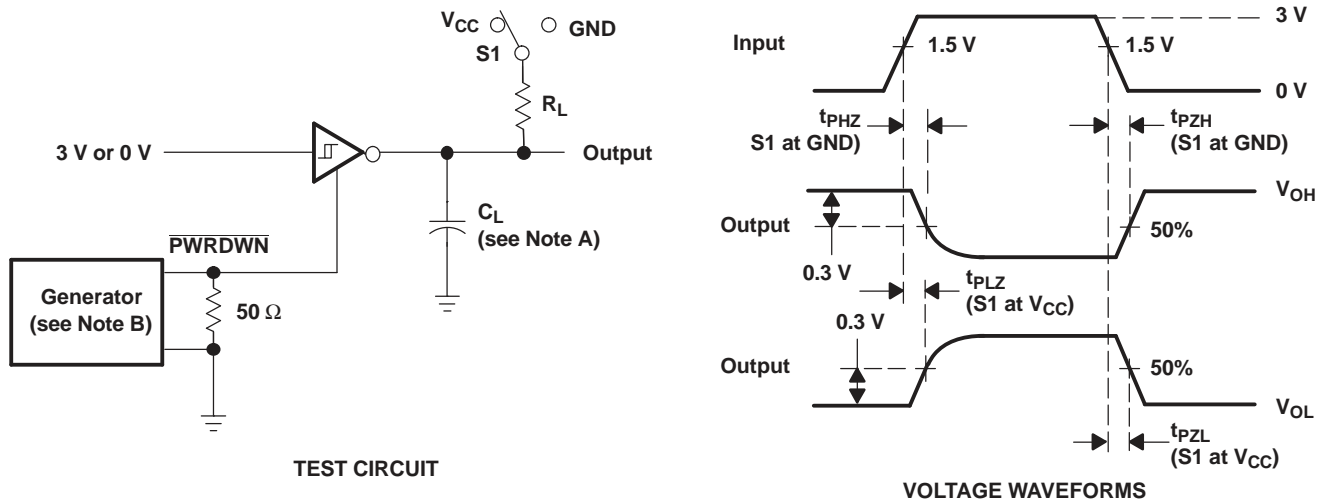

- NOTES: A. C_L includes probe and jig capacitance.
 B. The pulse generator has the following characteristics: $Z_O = 50 \Omega$, 50% duty cycle, $t_r \leq 10 \text{ ns}$, $t_f \leq 10 \text{ ns}$.

Figure 4. Receiver Enable and Disable Times

REVISION HISTORY

Changes from Revision B (April 2009) to Revision C	Page
• Changed V_L Pin for Compatibility With Mixed-Voltage Systems Down to 2.5 V (originally 1.8 V) on the Logic Side.	1
• Changed V_L Supply MIN value from 1.65 V to 2.25 V.	4
• Deleted $V_L = 1.65V$ parameter from Input logic threshold low.	4
• Deleted $V_L = 1.95V$ parameter from Input logic threshold high.	4

PACKAGING INFORMATION

Orderable Device	Status (1)	Package Type	Package Drawing	Pins	Package Qty	Eco Plan (2)	Lead/Ball Finish (6)	MSL Peak Temp (3)	Op Temp (°C)	Device Marking (4/5)	Samples
TRS3386ECDW	ACTIVE	SOIC	DW	20	25	Green (RoHS & no Sb/Br)	CU NIPDAU	Level-1-260C-UNLIM	0 to 70	TRS3386EC	Samples
TRS3386ECDWR	ACTIVE	SOIC	DW	20	2000	Green (RoHS & no Sb/Br)	CU NIPDAU	Level-1-260C-UNLIM	0 to 70	TRS3386EC	Samples
TRS3386ECPW	ACTIVE	TSSOP	PW	20	70	Green (RoHS & no Sb/Br)	CU NIPDAU	Level-1-260C-UNLIM	0 to 70	RV86EC	Samples
TRS3386ECPWR	ACTIVE	TSSOP	PW	20	2000	Green (RoHS & no Sb/Br)	CU NIPDAU	Level-1-260C-UNLIM	0 to 70	RV86EC	Samples
TRS3386ECPWRG4	ACTIVE	TSSOP	PW	20	2000	Green (RoHS & no Sb/Br)	CU NIPDAU	Level-1-260C-UNLIM	0 to 70	RV86EC	Samples
TRS3386EIDW	ACTIVE	SOIC	DW	20		TBD	Call TI	Call TI	-40 to 85	TRS3386EI	Samples
TRS3386EIDWR	ACTIVE	SOIC	DW	20	2000	Green (RoHS & no Sb/Br)	CU NIPDAU	Level-1-260C-UNLIM	-40 to 85	TRS3386EI	Samples
TRS3386EIPW	ACTIVE	TSSOP	PW	20	70	Green (RoHS & no Sb/Br)	CU NIPDAU	Level-1-260C-UNLIM	-40 to 85	RV86EI	Samples
TRS3386EIPWG4	ACTIVE	TSSOP	PW	20	70	Green (RoHS & no Sb/Br)	CU NIPDAU	Level-1-260C-UNLIM	-40 to 85	RV86EI	Samples
TRS3386EIPWR	ACTIVE	TSSOP	PW	20	2000	Green (RoHS & no Sb/Br)	CU NIPDAU	Level-1-260C-UNLIM	-40 to 85	RV86EI	Samples

(1) The marketing status values are defined as follows:

ACTIVE: Product device recommended for new designs.

LIFEBUY: TI has announced that the device will be discontinued, and a lifetime-buy period is in effect.

NRND: Not recommended for new designs. Device is in production to support existing customers, but TI does not recommend using this part in a new design.

PREVIEW: Device has been announced but is not in production. Samples may or may not be available.

OBSOLETE: TI has discontinued the production of the device.

(2) Eco Plan - The planned eco-friendly classification: Pb-Free (RoHS), Pb-Free (RoHS Exempt), or Green (RoHS & no Sb/Br) - please check <http://www.ti.com/productcontent> for the latest availability information and additional product content details.

TBD: The Pb-Free/Green conversion plan has not been defined.

Pb-Free (RoHS): TI's terms "Lead-Free" or "Pb-Free" mean semiconductor products that are compatible with the current RoHS requirements for all 6 substances, including the requirement that lead not exceed 0.1% by weight in homogeneous materials. Where designed to be soldered at high temperatures, TI Pb-Free products are suitable for use in specified lead-free processes.

Pb-Free (RoHS Exempt): This component has a RoHS exemption for either 1) lead-based flip-chip solder bumps used between the die and package, or 2) lead-based die adhesive used between the die and leadframe. The component is otherwise considered Pb-Free (RoHS compatible) as defined above.

Green (RoHS & no Sb/Br): TI defines "Green" to mean Pb-Free (RoHS compatible), and free of Bromine (Br) and Antimony (Sb) based flame retardants (Br or Sb do not exceed 0.1% by weight in homogeneous material)

- (3) MSL, Peak Temp. - The Moisture Sensitivity Level rating according to the JEDEC industry standard classifications, and peak solder temperature.
- (4) There may be additional marking, which relates to the logo, the lot trace code information, or the environmental category on the device.
- (5) Multiple Device Markings will be inside parentheses. Only one Device Marking contained in parentheses and separated by a "~" will appear on a device. If a line is indented then it is a continuation of the previous line and the two combined represent the entire Device Marking for that device.
- (6) Lead/Ball Finish - Orderable Devices may have multiple material finish options. Finish options are separated by a vertical ruled line. Lead/Ball Finish values may wrap to two lines if the finish value exceeds the maximum column width.

Important Information and Disclaimer:The information provided on this page represents TI's knowledge and belief as of the date that it is provided. TI bases its knowledge and belief on information provided by third parties, and makes no representation or warranty as to the accuracy of such information. Efforts are underway to better integrate information from third parties. TI has taken and continues to take reasonable steps to provide representative and accurate information but may not have conducted destructive testing or chemical analysis on incoming materials and chemicals. TI and TI suppliers consider certain information to be proprietary, and thus CAS numbers and other limited information may not be available for release.

In no event shall TI's liability arising out of such information exceed the total purchase price of the TI part(s) at issue in this document sold by TI to Customer on an annual basis.

TAPE AND REEL INFORMATION

QUADRANT ASSIGNMENTS FOR PIN 1 ORIENTATION IN TAPE

*All dimensions are nominal

Device	Package Type	Package Drawing	Pins	SPQ	Reel Diameter (mm)	Reel Width W1 (mm)	A0 (mm)	B0 (mm)	K0 (mm)	P1 (mm)	W (mm)	Pin1 Quadrant
TRS3386ECDWR	SOIC	DW	20	2000	330.0	24.4	10.8	13.0	2.7	12.0	24.0	Q1
TRS3386ECPWR	TSSOP	PW	20	2000	330.0	16.4	6.95	7.1	1.6	8.0	16.0	Q1
TRS3386EIDWR	SOIC	DW	20	2000	330.0	24.4	10.8	13.0	2.7	12.0	24.0	Q1
TRS3386EIPWR	TSSOP	PW	20	2000	330.0	16.4	6.95	7.1	1.6	8.0	16.0	Q1

TAPE AND REEL BOX DIMENSIONS



*All dimensions are nominal

Device	Package Type	Package Drawing	Pins	SPQ	Length (mm)	Width (mm)	Height (mm)
TRS3386ECDWR	SOIC	DW	20	2000	367.0	367.0	45.0
TRS3386ECPWR	TSSOP	PW	20	2000	367.0	367.0	38.0
TRS3386EIDWR	SOIC	DW	20	2000	367.0	367.0	45.0
TRS3386EIPWR	TSSOP	PW	20	2000	367.0	367.0	38.0

DW (R-PDSO-G20)

PLASTIC SMALL OUTLINE

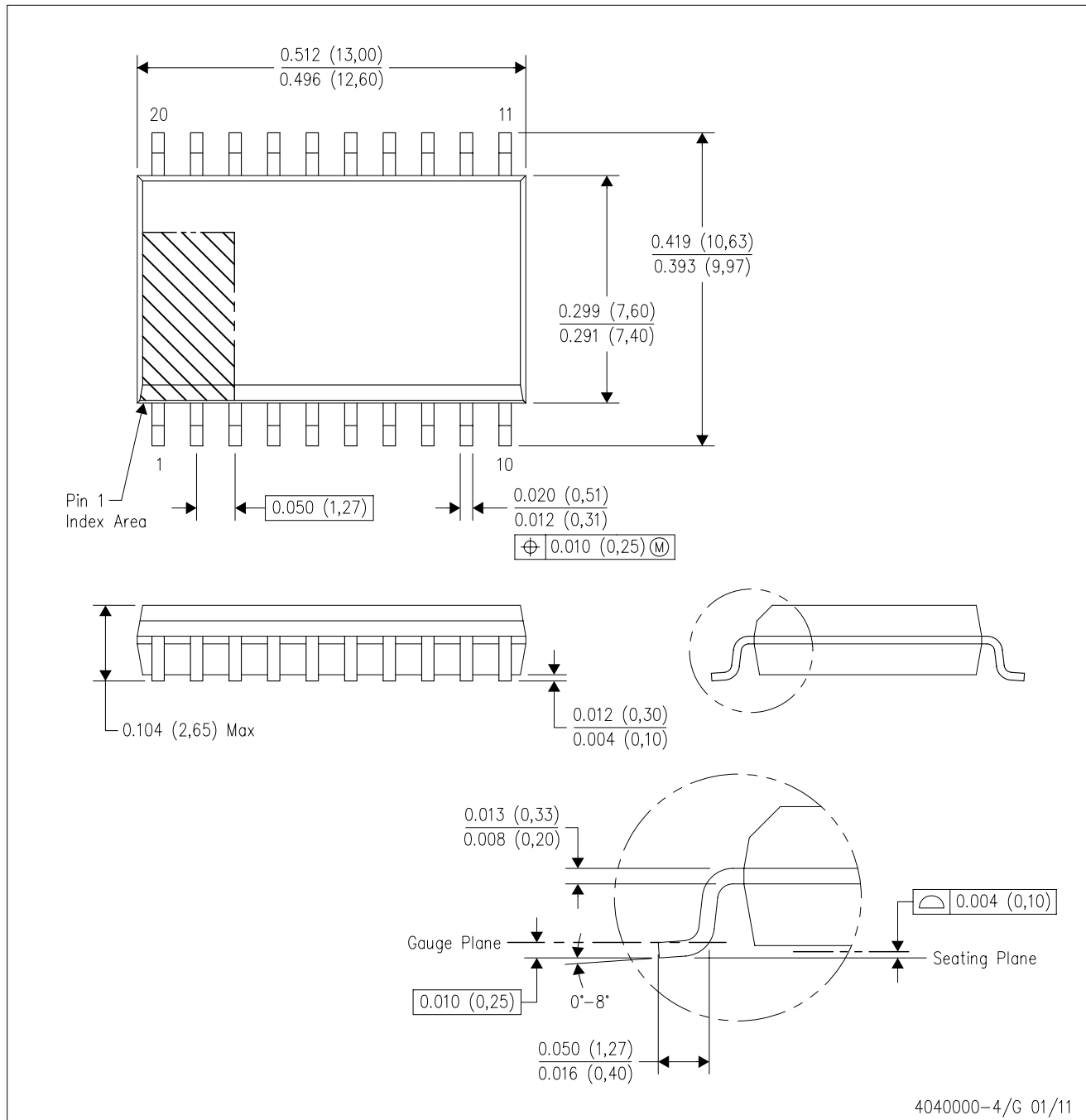

- NOTES:
- A. All linear dimensions are in inches (millimeters). Dimensioning and tolerancing per ASME Y14.5M-1994.
 - B. This drawing is subject to change without notice.
 - C. Body dimensions do not include mold flash or protrusion not to exceed 0.006 (0,15).
 - D. Falls within JEDEC MS-013 variation AC.

DW (R-PDSO-G20)

PLASTIC SMALL OUTLINE

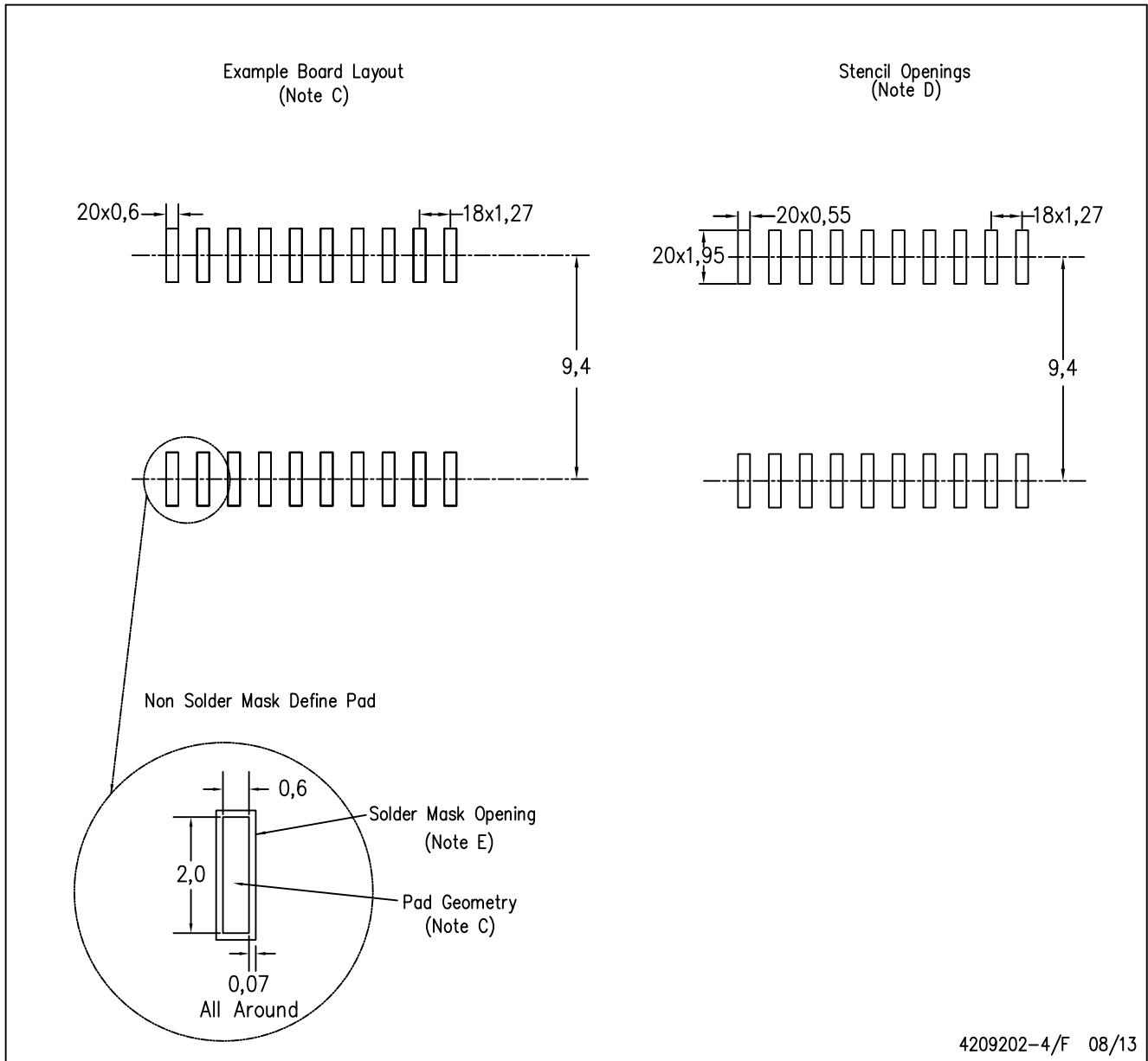

- NOTES:
- A. All linear dimensions are in millimeters.
 - B. This drawing is subject to change without notice.
 - C. Refer to IPC7351 for alternate board design.
 - D. Laser cutting apertures with trapezoidal walls and also rounding corners will offer better paste release. Customers should contact their board assembly site for stencil design recommendations. Refer to IPC-7525
 - E. Customers should contact their board fabrication site for solder mask tolerances between and around signal pads.

PW (R-PDSO-G20)

PLASTIC SMALL OUTLINE

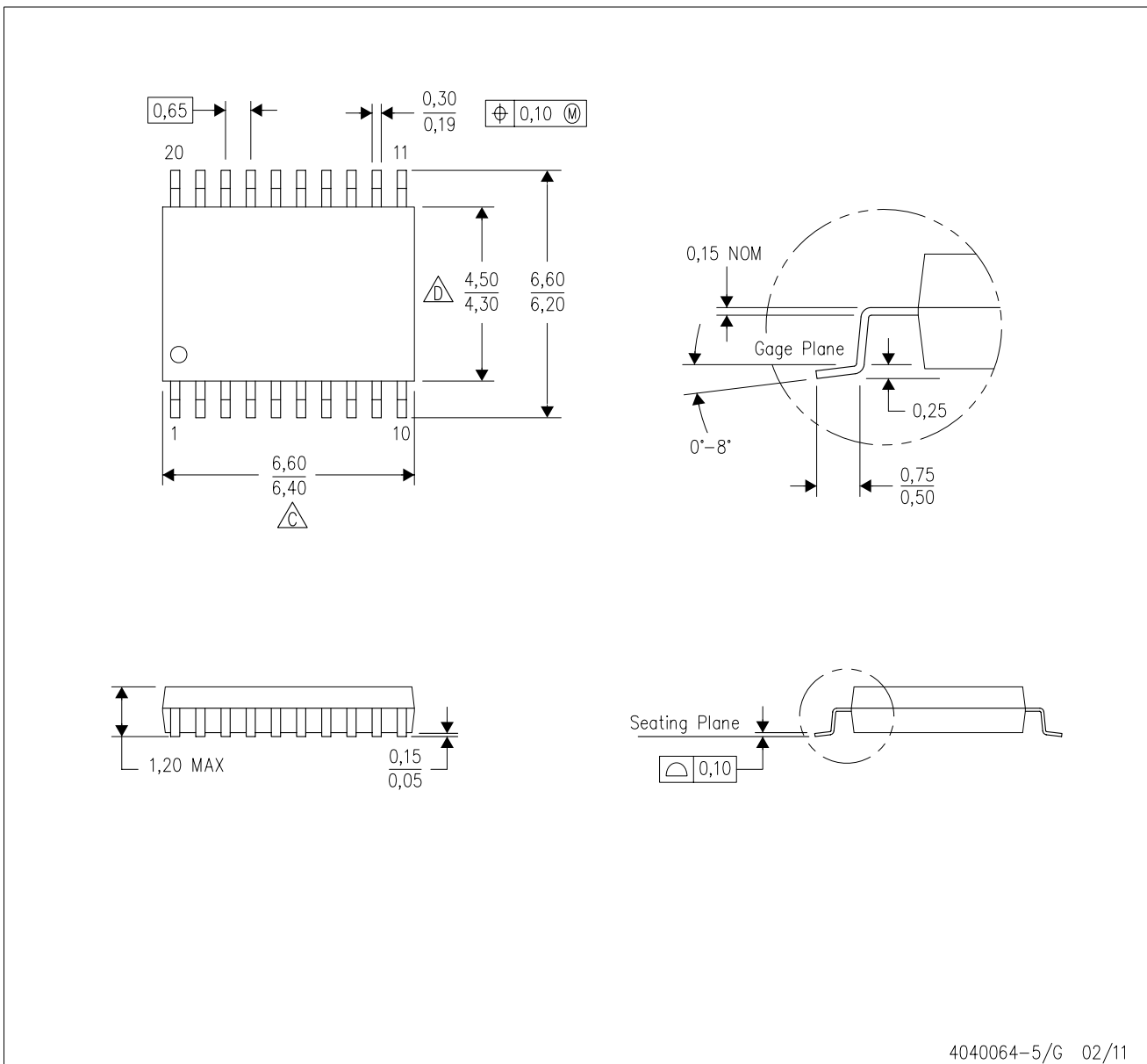

4040064-5/G 02/11

- NOTES:
- A. All linear dimensions are in millimeters. Dimensioning and tolerancing per ASME Y14.5M-1994.
 - B. This drawing is subject to change without notice.
 - C. Body length does not include mold flash, protrusions, or gate burrs. Mold flash, protrusions, or gate burrs shall not exceed 0,15 each side.
 - D. Body width does not include interlead flash. Interlead flash shall not exceed 0,25 each side.
 - E. Falls within JEDEC MO-153

PW (R-PDSO-G20)

PLASTIC SMALL OUTLINE

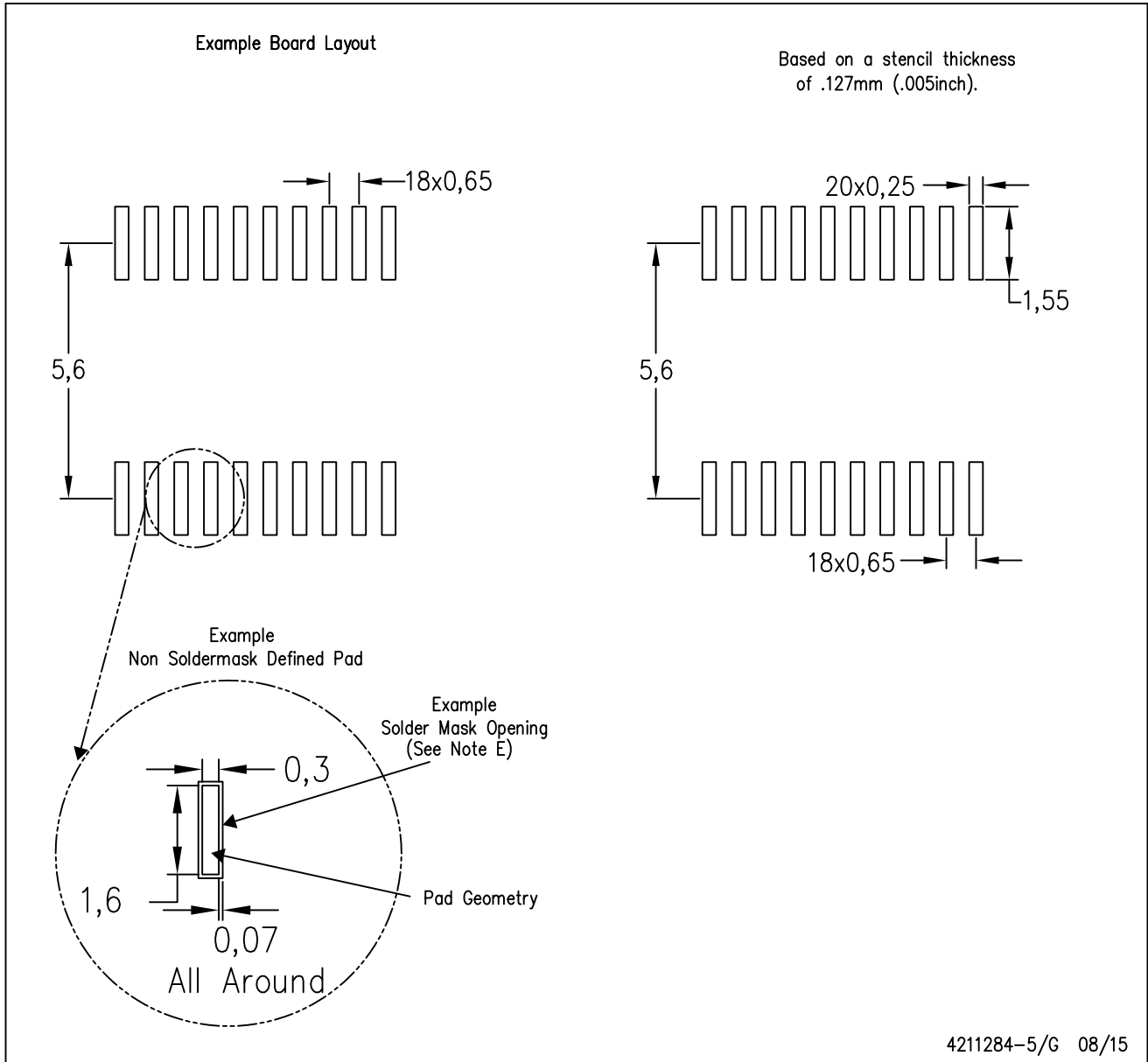

- NOTES:
- A. All linear dimensions are in millimeters.
 - B. This drawing is subject to change without notice.
 - C. Publication IPC-7351 is recommended for alternate design.
 - D. Laser cutting apertures with trapezoidal walls and also rounding corners will offer better paste release. Customers should contact their board assembly site for stencil design recommendations. Refer to IPC-7525 for other stencil recommendations.
 - E. Customers should contact their board fabrication site for solder mask tolerances between and around signal pads.

IMPORTANT NOTICE

Texas Instruments Incorporated and its subsidiaries (TI) reserve the right to make corrections, enhancements, improvements and other changes to its semiconductor products and services per JESD46, latest issue, and to discontinue any product or service per JESD48, latest issue. Buyers should obtain the latest relevant information before placing orders and should verify that such information is current and complete. All semiconductor products (also referred to herein as "components") are sold subject to TI's terms and conditions of sale supplied at the time of order acknowledgment.

TI warrants performance of its components to the specifications applicable at the time of sale, in accordance with the warranty in TI's terms and conditions of sale of semiconductor products. Testing and other quality control techniques are used to the extent TI deems necessary to support this warranty. Except where mandated by applicable law, testing of all parameters of each component is not necessarily performed.

TI assumes no liability for applications assistance or the design of Buyers' products. Buyers are responsible for their products and applications using TI components. To minimize the risks associated with Buyers' products and applications, Buyers should provide adequate design and operating safeguards.

TI does not warrant or represent that any license, either express or implied, is granted under any patent right, copyright, mask work right, or other intellectual property right relating to any combination, machine, or process in which TI components or services are used. Information published by TI regarding third-party products or services does not constitute a license to use such products or services or a warranty or endorsement thereof. Use of such information may require a license from a third party under the patents or other intellectual property of the third party, or a license from TI under the patents or other intellectual property of TI.

Reproduction of significant portions of TI information in TI data books or data sheets is permissible only if reproduction is without alteration and is accompanied by all associated warranties, conditions, limitations, and notices. TI is not responsible or liable for such altered documentation. Information of third parties may be subject to additional restrictions.

Resale of TI components or services with statements different from or beyond the parameters stated by TI for that component or service voids all express and any implied warranties for the associated TI component or service and is an unfair and deceptive business practice. TI is not responsible or liable for any such statements.

Buyer acknowledges and agrees that it is solely responsible for compliance with all legal, regulatory and safety-related requirements concerning its products, and any use of TI components in its applications, notwithstanding any applications-related information or support that may be provided by TI. Buyer represents and agrees that it has all the necessary expertise to create and implement safeguards which anticipate dangerous consequences of failures, monitor failures and their consequences, lessen the likelihood of failures that might cause harm and take appropriate remedial actions. Buyer will fully indemnify TI and its representatives against any damages arising out of the use of any TI components in safety-critical applications.

In some cases, TI components may be promoted specifically to facilitate safety-related applications. With such components, TI's goal is to help enable customers to design and create their own end-product solutions that meet applicable functional safety standards and requirements. Nonetheless, such components are subject to these terms.

No TI components are authorized for use in FDA Class III (or similar life-critical medical equipment) unless authorized officers of the parties have executed a special agreement specifically governing such use.

Only those TI components which TI has specifically designated as military grade or "enhanced plastic" are designed and intended for use in military/aerospace applications or environments. Buyer acknowledges and agrees that any military or aerospace use of TI components which have **not** been so designated is solely at the Buyer's risk, and that Buyer is solely responsible for compliance with all legal and regulatory requirements in connection with such use.

TI has specifically designated certain components as meeting ISO/TS16949 requirements, mainly for automotive use. In any case of use of non-designated products, TI will not be responsible for any failure to meet ISO/TS16949.

Products

Audio	www.ti.com/audio
Amplifiers	amplifier.ti.com
Data Converters	dataconverter.ti.com
DLP® Products	www.dlp.com
DSP	dsp.ti.com
Clocks and Timers	www.ti.com/clocks
Interface	interface.ti.com
Logic	logic.ti.com
Power Mgmt	power.ti.com
Microcontrollers	microcontroller.ti.com
RFID	www.ti-rfid.com
OMAP Applications Processors	www.ti.com/omap
Wireless Connectivity	www.ti.com/wirelessconnectivity

Applications

Automotive and Transportation	www.ti.com/automotive
Communications and Telecom	www.ti.com/communications
Computers and Peripherals	www.ti.com/computers
Consumer Electronics	www.ti.com/consumer-apps
Energy and Lighting	www.ti.com/energy
Industrial	www.ti.com/industrial
Medical	www.ti.com/medical
Security	www.ti.com/security
Space, Avionics and Defense	www.ti.com/space-avionics-defense
Video and Imaging	www.ti.com/video

TI E2E Community

e2e.ti.com