

# INA105

## Precision Unity Gain DIFFERENTIAL AMPLIFIER

### FEATURES

- CMR 86dB min OVER TEMPERATURE
- GAIN ERROR: 0.01% max
- NONLINEARITY: 0.001% max
- NO EXTERNAL ADJUSTMENTS REQUIRED
- EASY TO USE
- COMPLETE SOLUTION
- HIGHLY VERSATILE
- LOW COST
- PLASTIC DIP, TO-99 HERMETIC METAL, AND SO-8 SOIC PACKAGES

### APPLICATIONS

- DIFFERENTIAL AMPLIFIER
- INSTRUMENTATION AMPLIFIER BUILDING BLOCK
- UNITY-GAIN INVERTING AMPLIFIER
- GAIN-OF-1/2 AMPLIFIER
- NONINVERTING GAIN-OF-2 AMPLIFIER
- AVERAGE VALUE AMPLIFIER
- ABSOLUTE VALUE AMPLIFIER
- SUMMING AMPLIFIER
- SYNCHRONOUS DEMODULATOR
- CURRENT RECEIVER WITH COMPLIANCE TO RAILS
- 4mA TO 20mA TRANSMITTER
- VOLTAGE-CONTROLLED CURRENT SOURCE
- ALL-PASS FILTERS

### DESCRIPTION

The INA105 is a monolithic Gain = 1 differential amplifier consisting of a precision op amp and on-chip metal film resistors. The resistors are laser trimmed for accurate gain and high common-mode rejection. Excellent TCR tracking of the resistors maintains gain accuracy and common-mode rejection over temperature.

The differential amplifier is the foundation of many commonly used circuits. The INA105 provides this precision circuit function without using an expensive precision resistor network. The INA105 is available in 8-pin plastic DIP, SO-8 surface-mount and TO-99 metal packages.

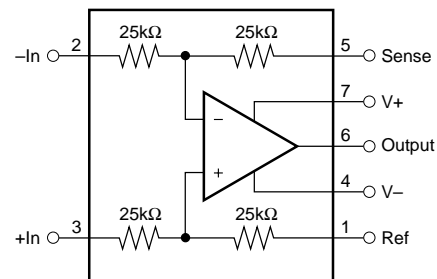

# SPECIFICATIONS

## ELECTRICAL

At +25°C,  $V_{CC} = \pm 15V$ , unless otherwise noted.

PARAMETER	CONDITIONS	INA105AM			INA105BM			INA105KP, KU			UNITS
		MIN	TYP	MAX	MIN	TYP	MAX	MIN	TYP	MAX	
<b>GAIN</b>											
Initial <sup>(1)</sup>			1			*			*		V/V
Error vs Temperature			0.005	0.01		*	*		0.01	0.025	%
Nonlinearity <sup>(2)</sup>			1	5		*	*		*	*	ppm/°C
			0.0002	0.001		*	*		*	*	%
<b>OUTPUT</b>											
Rated Voltage	$I_O = +20mA, -5mA$	10	12		*	*		*	*		V
Rated Current	$V_O = 10V$	+20, -5			*			*			mA
Impedance			0.01			*			*		$\Omega$
Current Limit	To Common		+40/-10			*			*		mA
Capacitive Load	Stable Operation		1000			*			*		pF
<b>INPUT</b>											
Impedance <sup>(3)</sup>	Differential		50			*			*		k $\Omega$
	Common-Mode		50			*			*		k $\Omega$
Voltage Range <sup>(4)</sup>	Differential	$\pm 10$			*			*			V
	Common-Mode	$\pm 20$			*			*			V
Common-Mode Rejection <sup>(5)</sup>	$T_A = T_{MIN}$ to $T_{MAX}$	80	90		86	100		72	*		dB
<b>OFFSET VOLTAGE</b>											
Initial	RTO <sup>(6), (7)</sup>		50	250		*	*		*	500	$\mu V$
vs Temperature			5	20		5	10		*	*	$\mu V/°C$
vs Supply	$\pm V_S = 6V$ to $18V$		1	25		*	15		*	*	$\mu V/V$
vs Time			20			*			*	*	$\mu V/mo$
<b>OUTPUT NOISE VOLTAGE</b>											
$f_B = 0.01Hz$ to $10Hz$	RTO <sup>(6), (8)</sup>		2.4			*			*		$\mu Vp-p$
$f_O = 10kHz$			60			*			*		$nV/\sqrt{Hz}$
<b>DYNAMIC RESPONSE</b>											
Small Signal Bandwidth	-3dB		1			*			*		MHz
Full Power Bandwidth	$V_O = 20Vp-p$	30	50		*	*		*	*		kHz
Slew Rate		2	3		*	*		*	*		V/ $\mu s$
Settling Time: 0.1%	$V_O = 10V$ Step		4			*			*		$\mu s$
0.01%	$V_O = 10V$ Step		5			*			*		$\mu s$
0.01%	$V_{CM} = 10V$ Step, $V_{DIFF} = 0V$		1.5			*			*		$\mu s$
<b>POWER SUPPLY</b>											
Rated			$\pm 15$			*			*		V
Voltage Range	Derated Performance	$\pm 5$		$\pm 18$	*	*	*	*	*	*	V
Quiescent Current	$V_O = 0V$		$\pm 1.5$	$\pm 2$		*	*		*	*	mA
<b>TEMPERATURE RANGE</b>											
Specification		-40		+85	*		*	*		*	°C
Operation		-55		+125	*		*	-40		+85	°C
Storage		-65		+150	*		*	-40		+125	°C

\* Specification same as for INA105AM.

NOTES: (1) Connected as difference amplifier (see Figure 4). (2) Nonlinearity is the maximum peak deviation from the best-fit straight line as a percent of full-scale peak-to-peak output. (3) 25k $\Omega$  resistors are ratio matched but have  $\pm 20\%$  absolute value. (4) Maximum input voltage without protection is 10V more than either  $\pm 15V$  supply ( $\pm 25V$ ). Limit  $I_{IN}$  to 1mA. (5) With zero source impedance (see "Maintaining CMR" section). (6) Referred to output in unity-gain difference configuration. Note that this circuit has a gain of 2 for the operational amplifier's offset voltage and noise voltage. (7) Includes effects of amplifier's input bias and offset currents. (8) Includes effects of amplifier's input current noise and thermal noise contribution of resistor network.

The information provided herein is believed to be reliable; however, BURR-BROWN assumes no responsibility for inaccuracies or omissions. BURR-BROWN assumes no responsibility for the use of this information, and all use of such information shall be entirely at the user's own risk. Prices and specifications are subject to change without notice. No patent rights or licenses to any of the circuits described herein are implied or granted to any third party. BURR-BROWN does not authorize or warrant any BURR-BROWN product for use in life support devices and/or systems.

## PIN CONFIGURATIONS

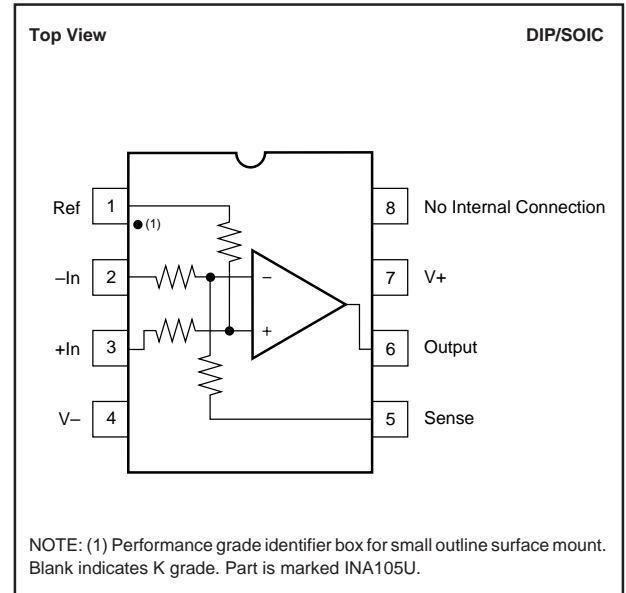
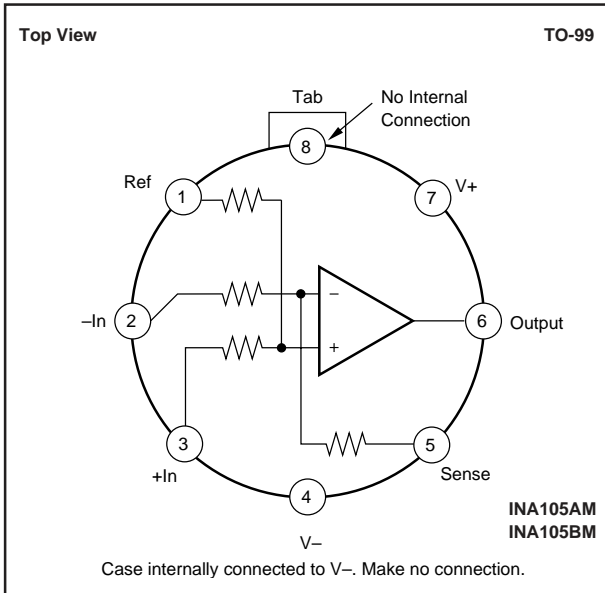

## ABSOLUTE MAXIMUM RATINGS

Supply .....	±18V
Input Voltage Range .....	±V <sub>S</sub>
Operating Temperature Range: M .....	-55°C to +125°C
P, U .....	-40°C to +85°C
Storage Temperature Range: M .....	-65°C to +150°C
P, U .....	-40°C to +125°C
Lead Temperature (soldering, 10s) M, P .....	+300°C
Wave Soldering (3s, max) U .....	+260°C
Output Short Circuit to Common .....	Continuous

## PACKAGE/ORDERING INFORMATION

PRODUCT	PACKAGE	PACKAGE DRAWING NUMBER <sup>(1)</sup>	TEMPERATURE RANGE
INA105AM	TO-99 Metal	001	-40°C to +85°C
INA105BM	TO-99 Metal	001	-40°C to +85°C
INA105KP	8-Pin Plastic DIP	006	-40°C to +85°C
INA105KU	8-Pin SOIC	182	-40°C to +85°C

NOTE: (1) For detailed drawing and dimension table, please see end of data sheet, or Appendix C of Burr-Brown IC Data Book.



## ELECTROSTATIC DISCHARGE SENSITIVITY

This integrated circuit can be damaged by ESD. Burr-Brown recommends that all integrated circuits be handled with appropriate precautions. Failure to observe proper handling and installation procedures can cause damage.

ESD damage can range from subtle performance degradation to complete device failure. Precision integrated circuits may be more susceptible to damage because very small parametric changes could cause the device not to meet its published specifications.

# TYPICAL PERFORMANCE CURVES

At  $T_A = 25^\circ\text{C}$ ,  $V_S = \pm 15\text{V}$ , unless otherwise noted.

STEP RESPONSE



SMALL SIGNAL RESPONSE  
(No Load)



SMALL SIGNAL RESPONSE  
( $R_{LOAD} = \infty\Omega$ ,  $C_{LOAD} = 1000\text{pF}$ )



MAXIMUM  $V_{OUT}$  vs  $I_{OUT}$   
(Negative Swing)

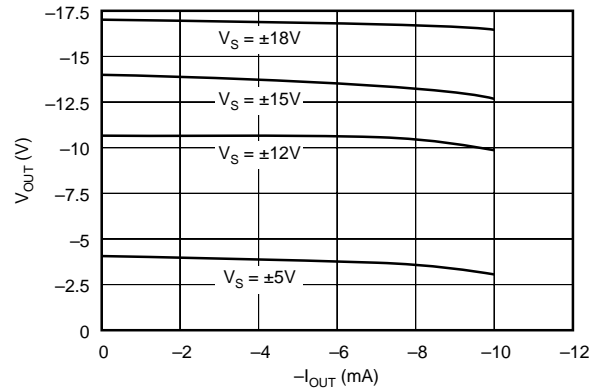

MAXIMUM  $V_{OUT}$  vs  $I_{OUT}$   
(Positive Swing)

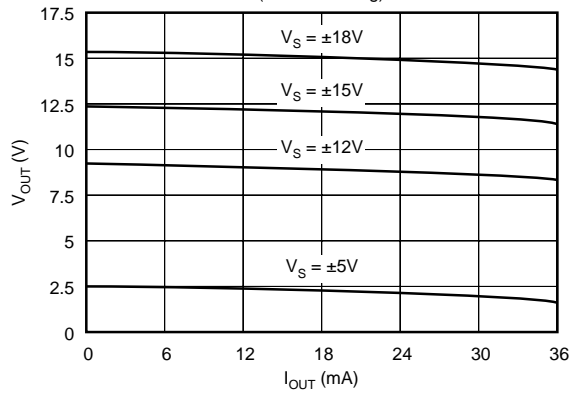

CMR vs FREQUENCY

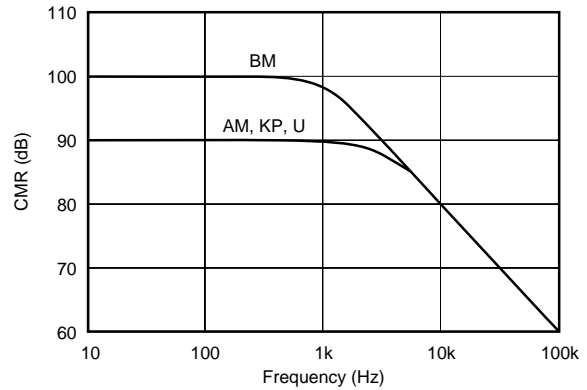

# TYPICAL PERFORMANCE CURVES (CONT)

At  $T_A = 25^\circ\text{C}$ ,  $V_S = \pm 15\text{V}$ , unless otherwise noted.

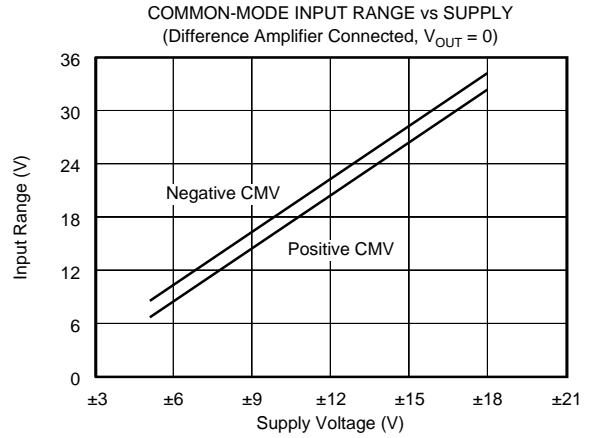
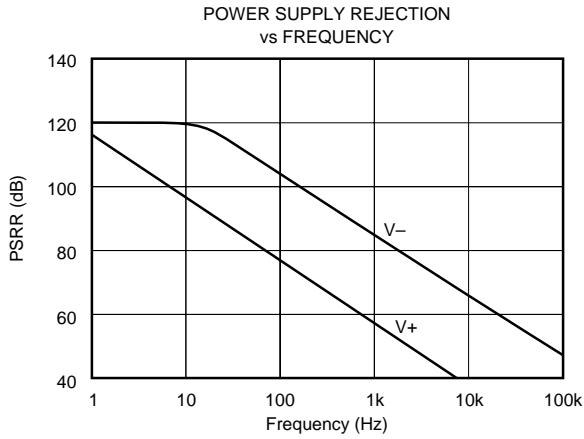

## APPLICATION INFORMATION

Figure 1 shows the basic connections required for operation of the INA105. Power supply bypass capacitors should be connected close to the device pins.

The differential input signal is connected to pins 2 and 3 as shown. The source impedances connected to the inputs must be nearly equal to assure good common-mode rejection. A  $5\Omega$  mismatch in source impedance will degrade the common-mode rejection of a typical device to approximately 80dB. If the source has a known mismatch in source impedance, an additional resistor in series with one input can be used to preserve good common-mode rejection.

The output is referred to the output reference terminal (pin 1) which is normally grounded. A voltage applied to the Ref terminal will be summed with the output signal. This can be used to null offset voltage as shown in Figure 2. The source impedance of a signal applied to the Ref terminal should be less than  $10\Omega$  to maintain good common-mode rejection.

Do not interchange pins 1 and 3 or pins 2 and 5, even though nominal resistor values are equal. These resistors are laser trimmed for precise resistor ratios to achieve accurate gain and highest CMR. Interchanging these pins would not provide specified performance.

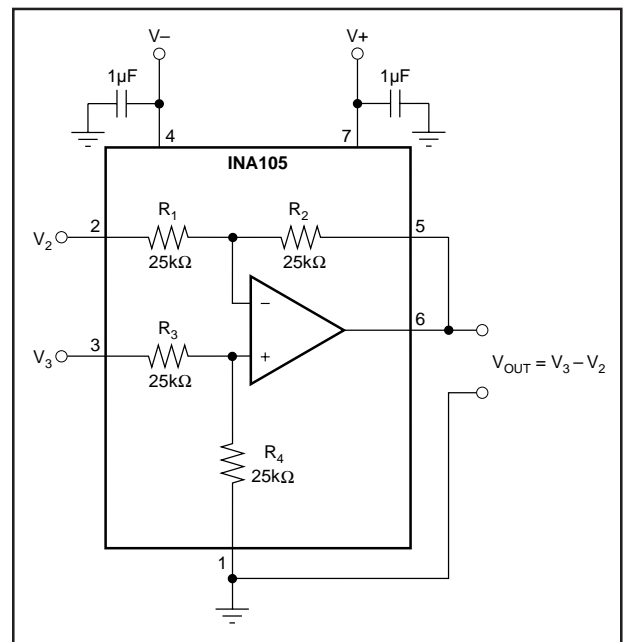

FIGURE 1. Basic Power Supply and Signal Connections.

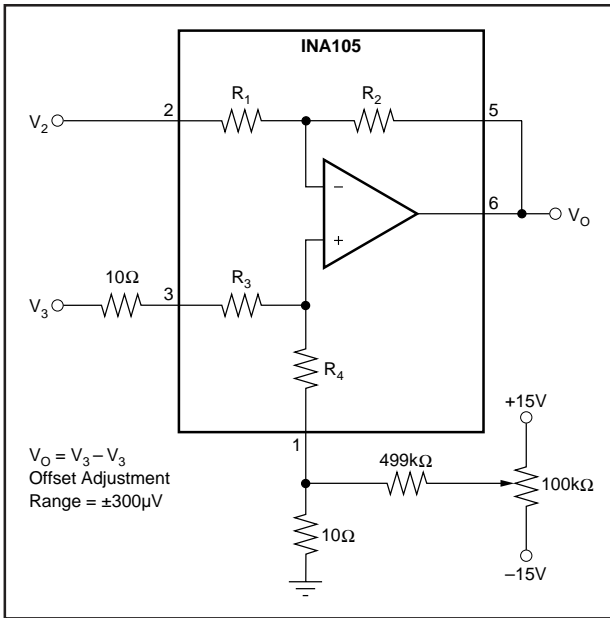

FIGURE 2. Offset Adjustment.

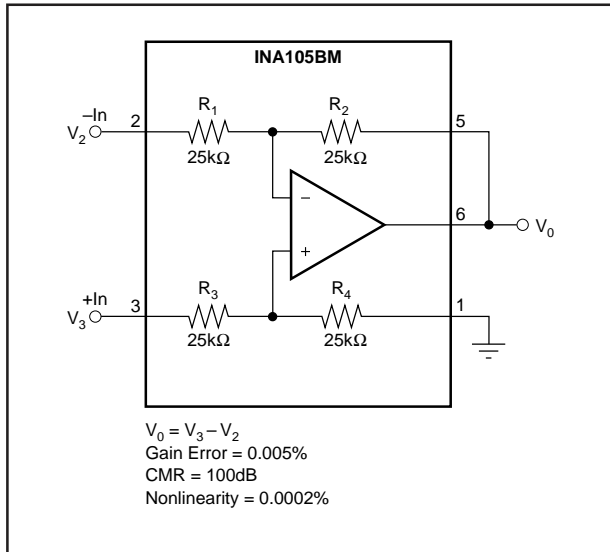

FIGURE 3. Precision Difference Amplifier.

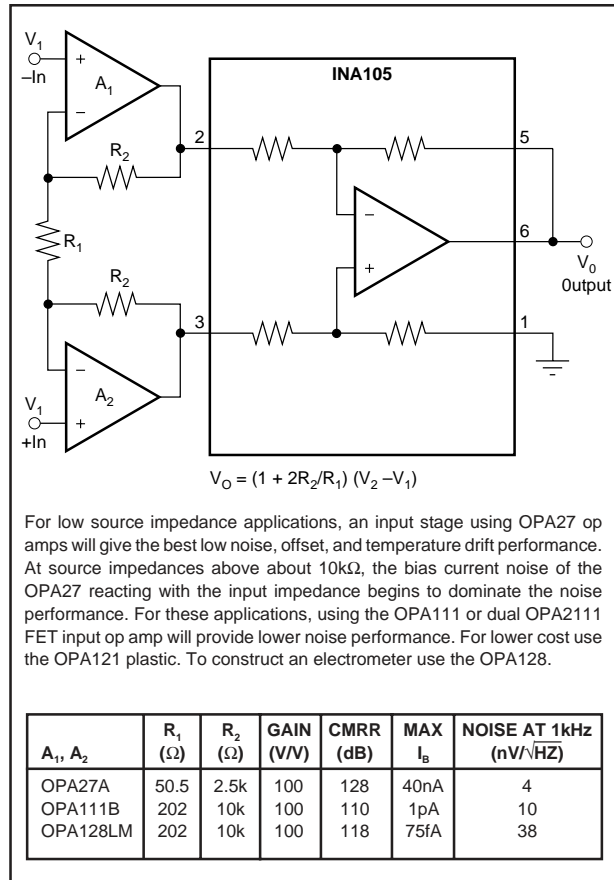

FIGURE 4. Precision Instrumentation Amplifier.

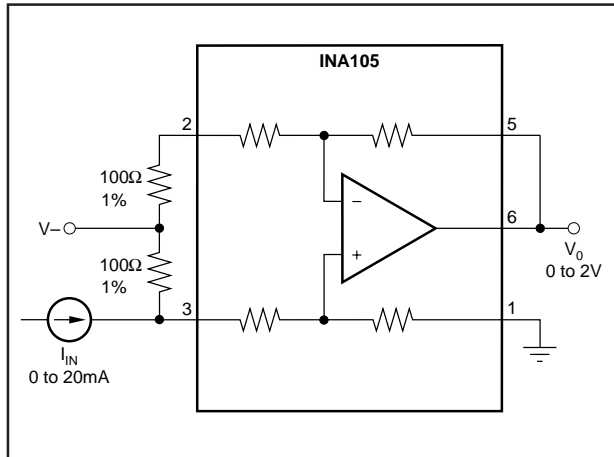

FIGURE 5. Current Receiver with Compliance to Rails.

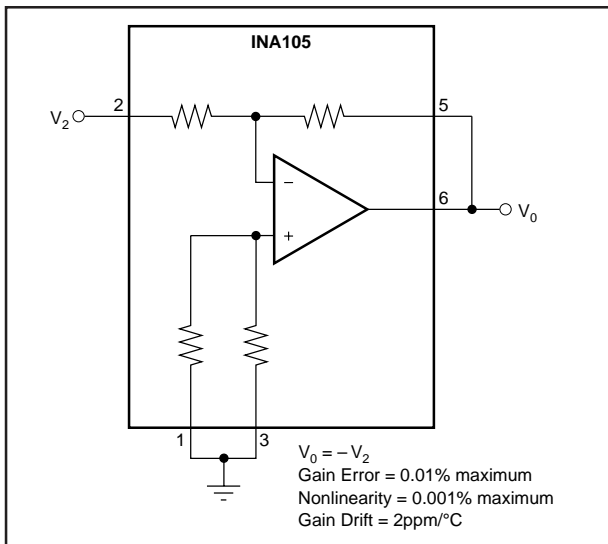

FIGURE 6. Precision Unity-Gain Inverting Amplifier.

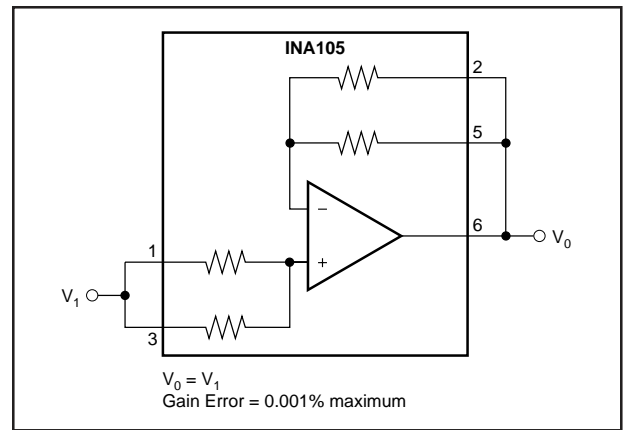

FIGURE 9. Precision Unity-Gain Buffer.

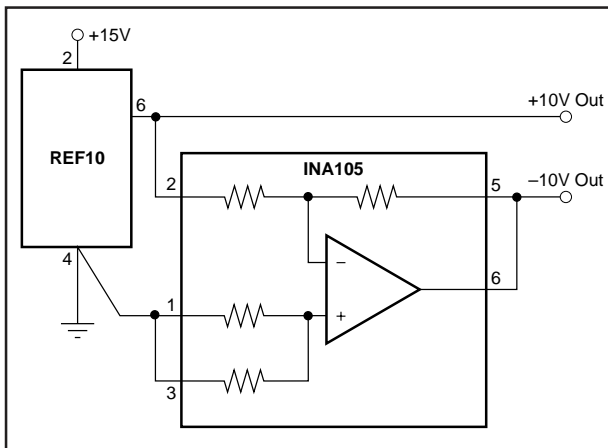

FIGURE 7. ±10V Precision Voltage Reference.

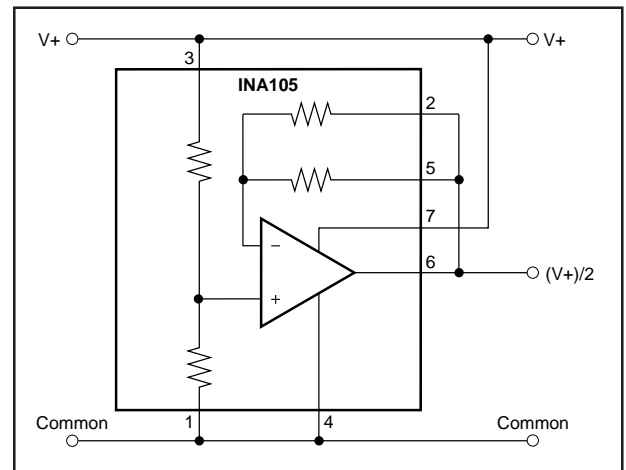

FIGURE 10. Pseudoground Generator.

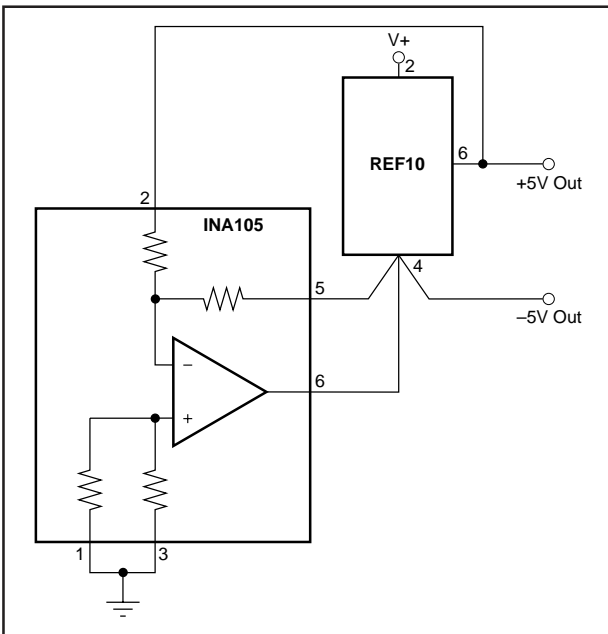

FIGURE 8. ±5V Precision Voltage Reference.

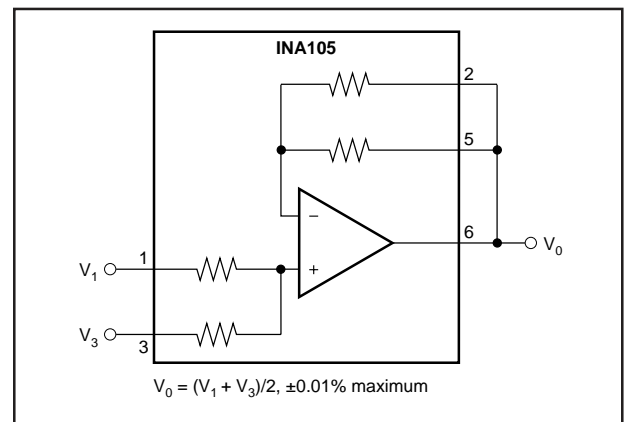

FIGURE 11. Precision Average Value Amplifier.

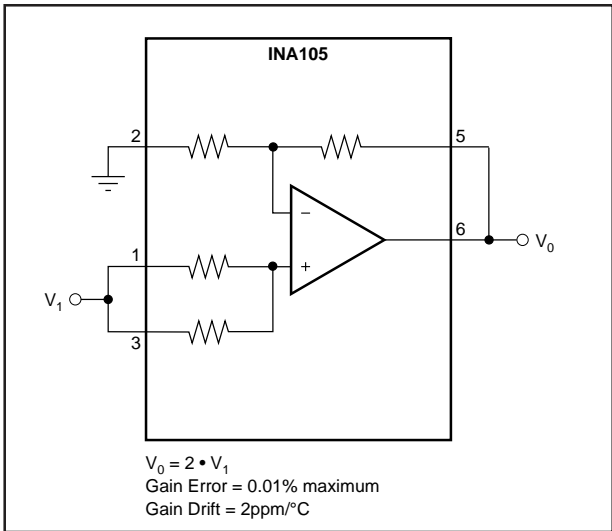

FIGURE 12. Precision (G = 2) Amplifier.

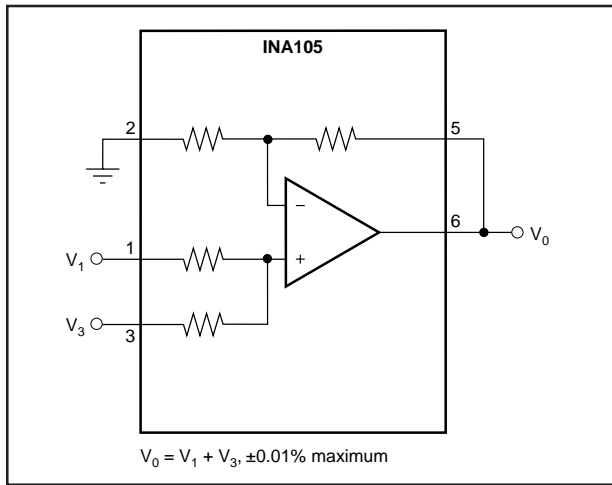

FIGURE 13. Precision Summing Amplifier.

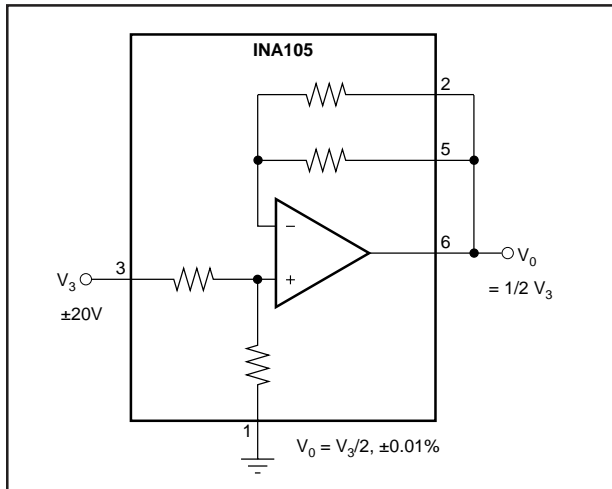

FIGURE 14. Precision Gain = 1/2 Amplifier.

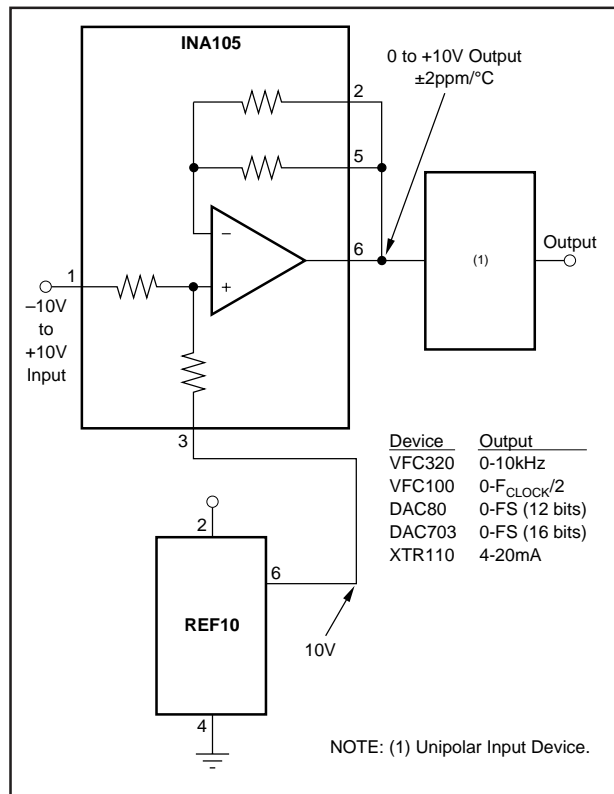

FIGURE 15. Precision Bipolar Offsetting.

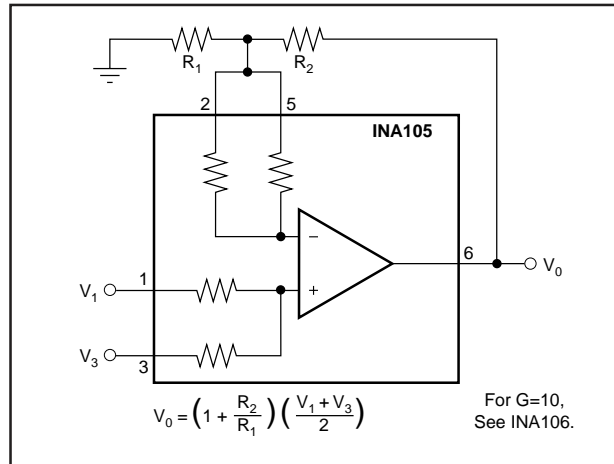

FIGURE 16. Precision Summing Amplifier with Gain.



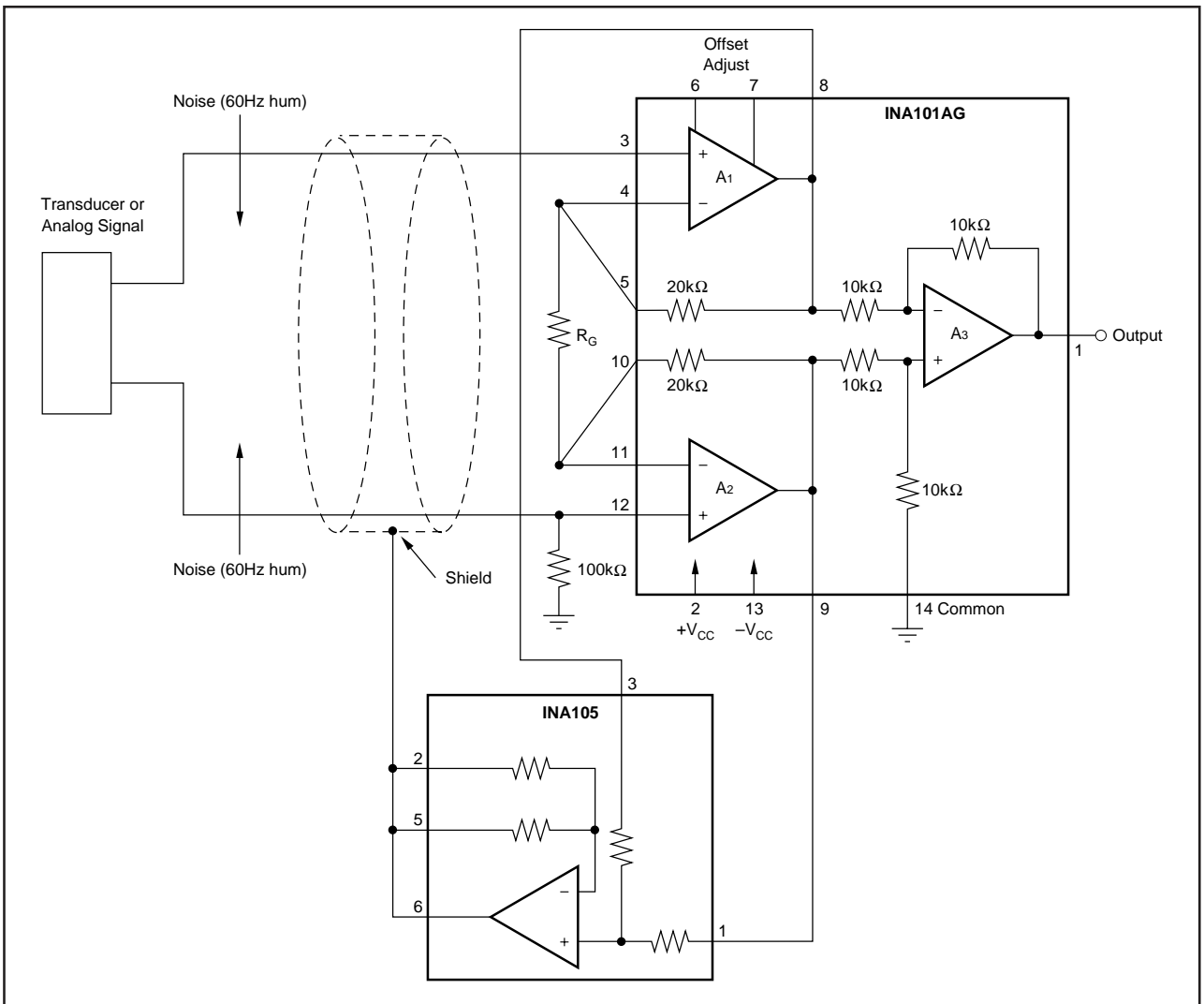

FIGURE 17. Instrumentation Amplifier Guard Drive Generator.

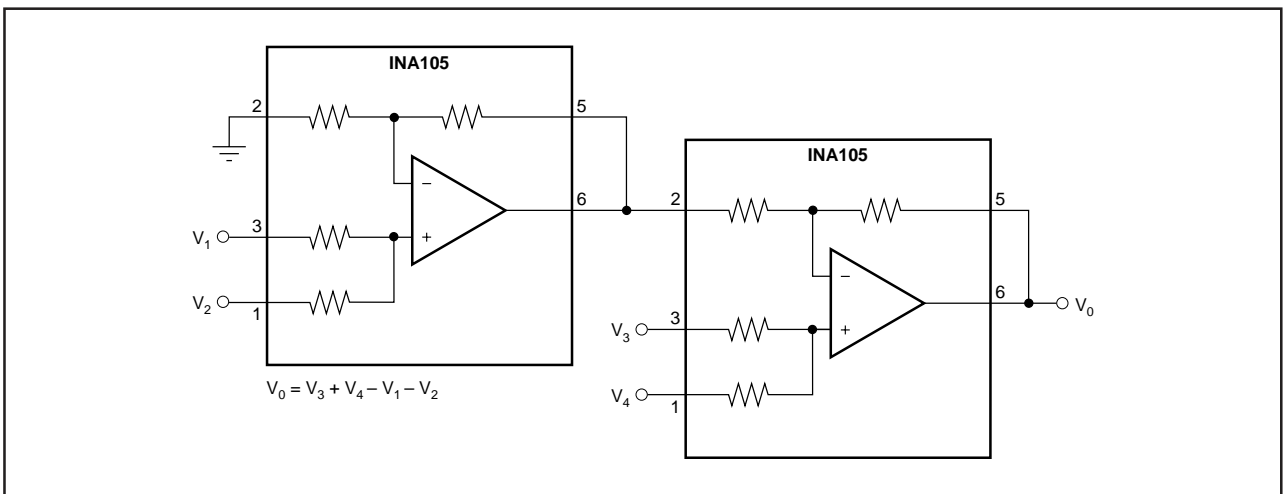

FIGURE 18. Precision Summing Instrumentation Amplifier.

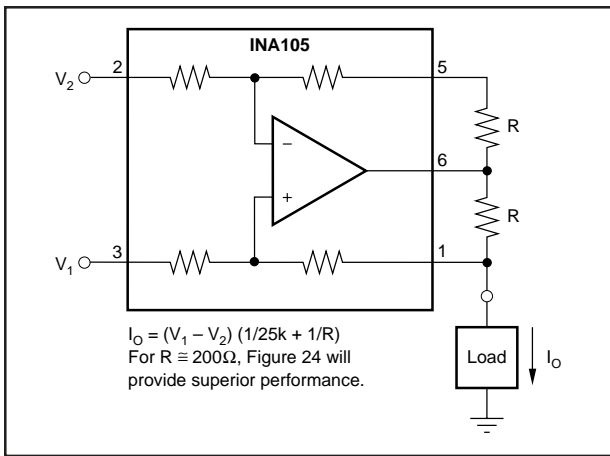

FIGURE 19. Precision Voltage-to-Current Converter with Differential Inputs.

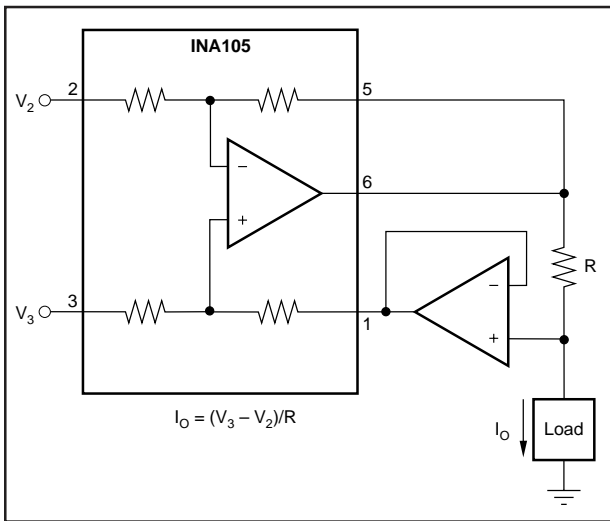

FIGURE 20. Differential Input Voltage-to-Current Converter for Low  $I_{OUT}$ .

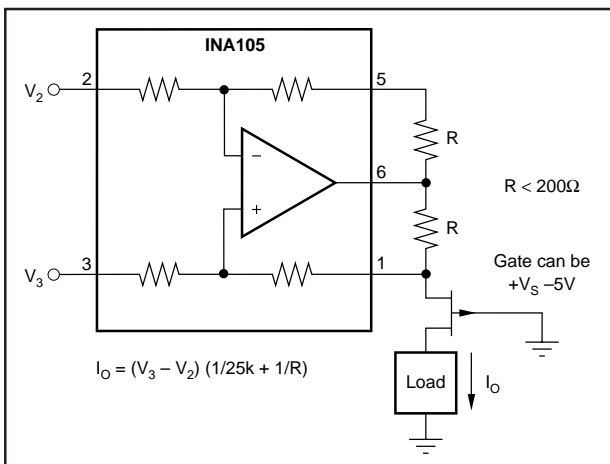

FIGURE 21. Isolating Current Source.

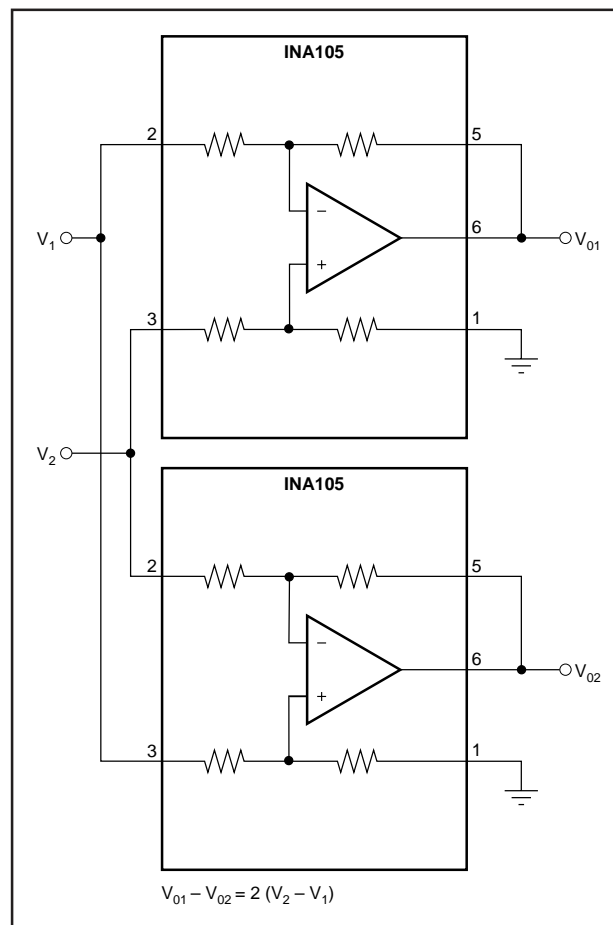

FIGURE 22. Differential Output Difference Amplifier.

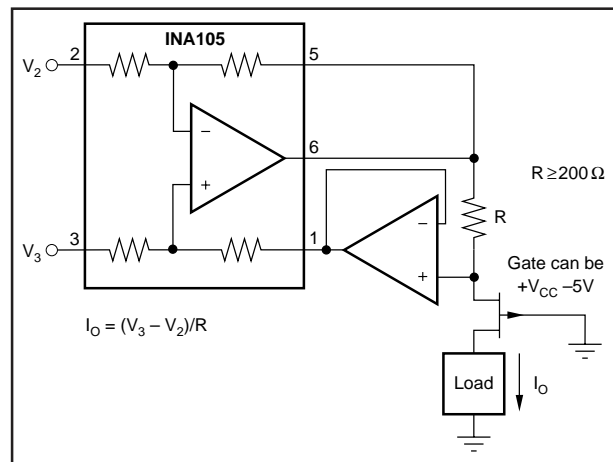

FIGURE 23. Isolating Current Source with Buffering Amplifier for Greater Accuracy.

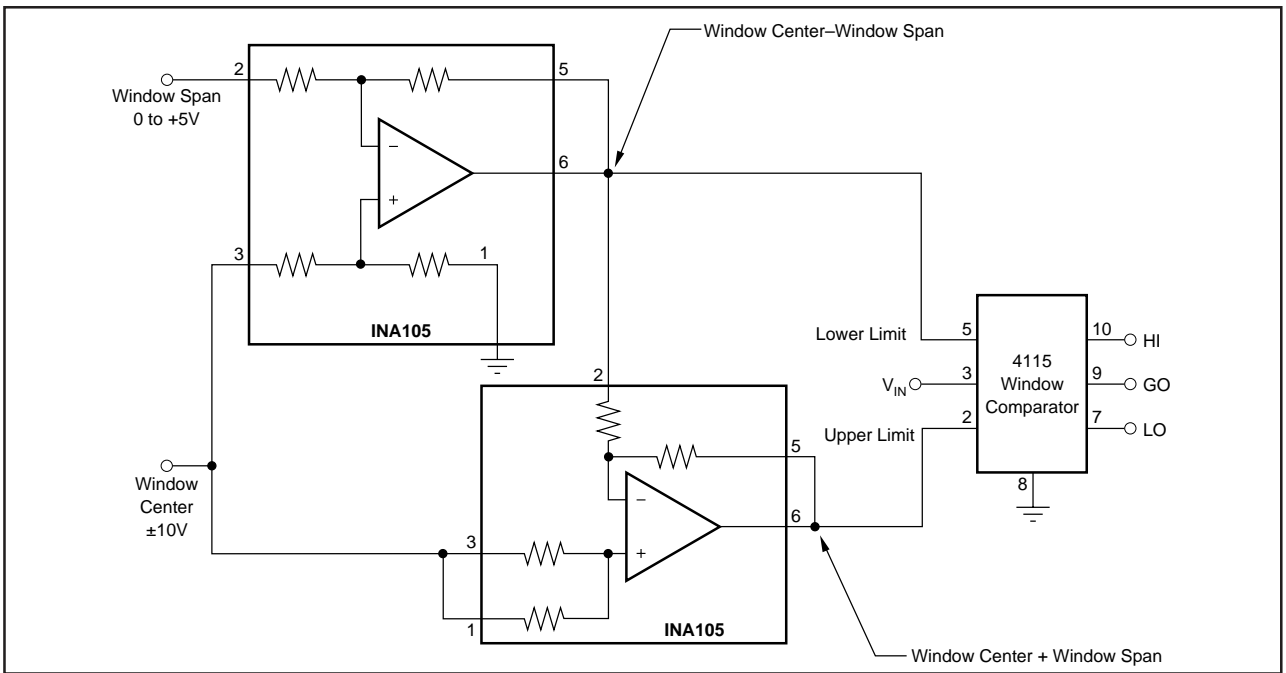

FIGURE 24. Window Comparator with Window Span and Window Center Inputs.

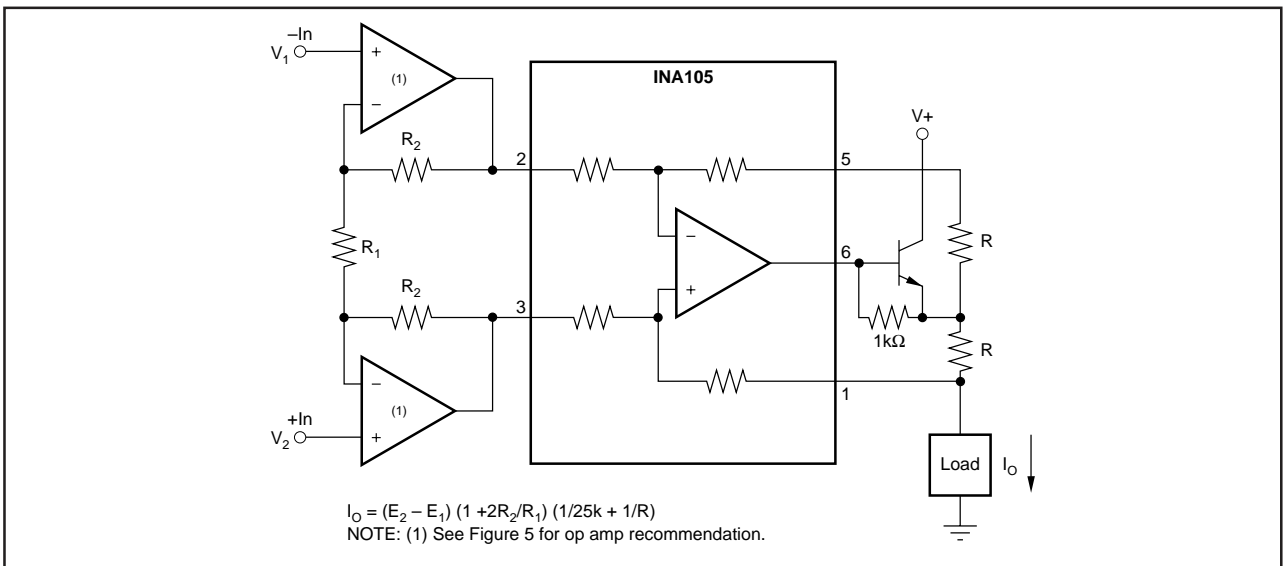

FIGURE 25. Precision Voltage-Controlled Current Source with Buffered Differential Inputs and Gain.

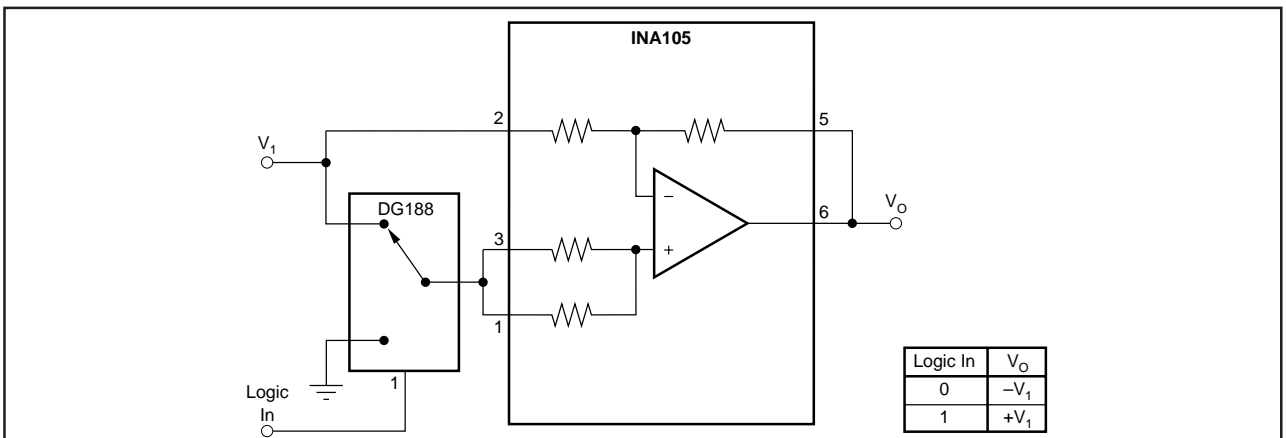

FIGURE 26. Digitally Controlled Gain of ±1 Amplifier.

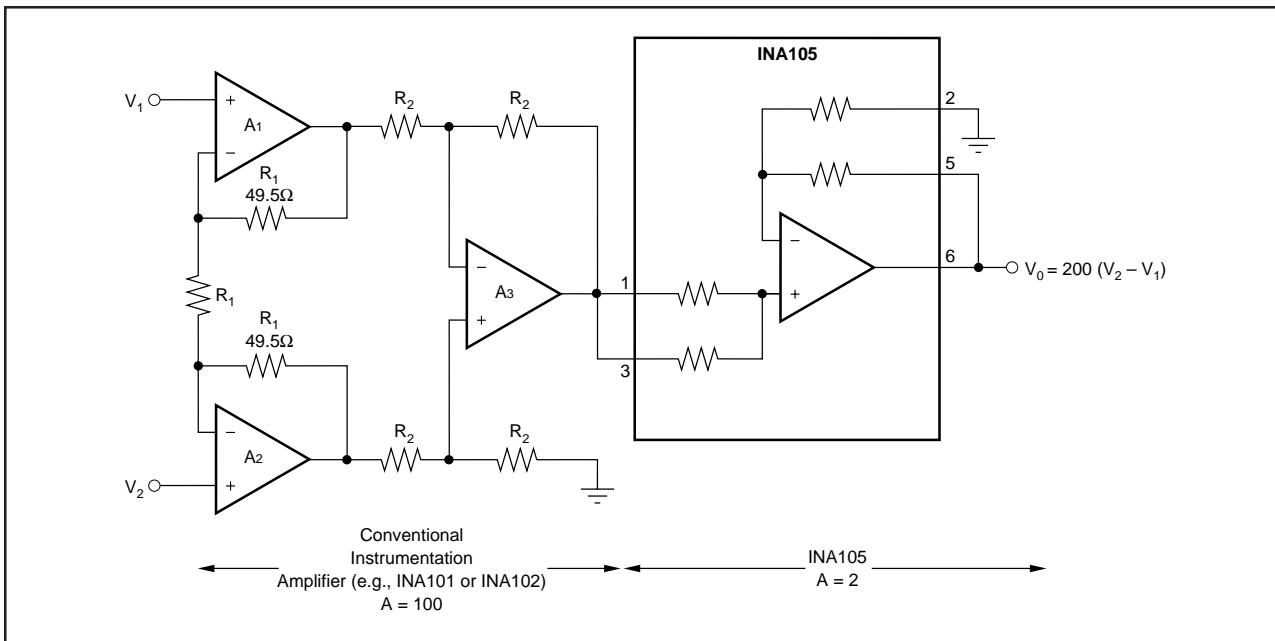

FIGURE 27. Boosting Instrumentation Amplifier Common-Mode Range From  $\pm 5$  to  $\pm 7.5$ V with 10V Full-Scale Output.

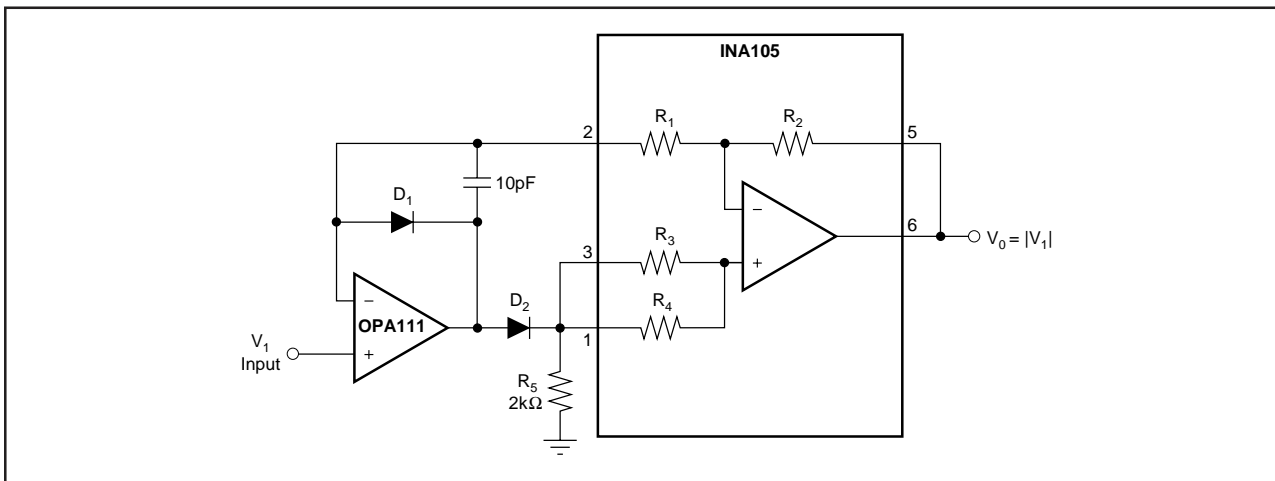

FIGURE 28. Precision Absolute Value Buffer.

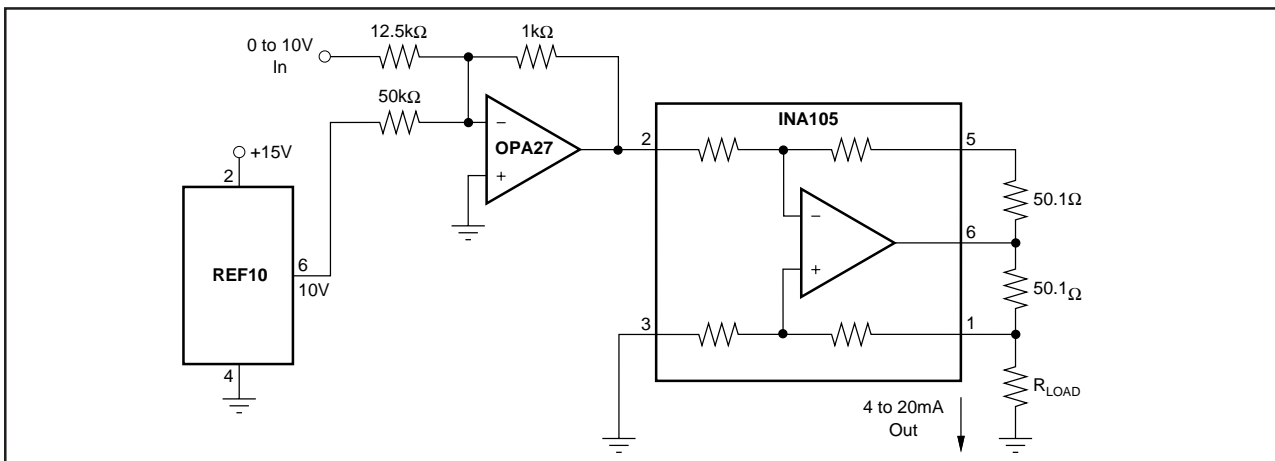

FIGURE 29. Precision 4-20mA Current Transmitter.

## PACKAGING INFORMATION

Orderable Device	Status (1)	Package Type	Package Drawing	Pins	Package Qty	Eco Plan (2)	Lead finish/ Ball material (6)	MSL Peak Temp (3)	Op Temp (°C)	Device Marking (4/5)	Samples
INA105AM	LIFEBUY	TO-99	LMC	8	1	RoHS & Green	Call TI	N / A for Pkg Type		INA105AM	
INA105BM	LIFEBUY	TO-99	LMC	8	1	RoHS & Green	Call TI	N / A for Pkg Type		INA105BM	
INA105KP	ACTIVE	PDIP	P	8	50	RoHS & Green	NIPDAU	N / A for Pkg Type		INA105KP	Samples
INA105KPG4	LIFEBUY	PDIP	P	8	50	RoHS & Green	NIPDAU	N / A for Pkg Type		INA105KP	
INA105KU	LIFEBUY	SOIC	D	8	75	RoHS & Green	NIPDAU	Level-3-260C-168 HR	-40 to 85	INA 105U	
INA105KU/2K5	ACTIVE	SOIC	D	8	2500	RoHS & Green	NIPDAU	Level-3-260C-168 HR	-40 to 85	INA 105U	Samples
INA105KU/2K5E4	LIFEBUY	SOIC	D	8	2500	RoHS & Green	NIPDAU	Level-3-260C-168 HR	-40 to 85	INA 105U	
INA105KUE4	LIFEBUY	SOIC	D	8	75	RoHS & Green	NIPDAU	Level-3-260C-168 HR	-40 to 85	INA 105U	

(1) The marketing status values are defined as follows:

**ACTIVE:** Product device recommended for new designs.

**LIFEBUY:** TI has announced that the device will be discontinued, and a lifetime-buy period is in effect.

**NRND:** Not recommended for new designs. Device is in production to support existing customers, but TI does not recommend using this part in a new design.

**PREVIEW:** Device has been announced but is not in production. Samples may or may not be available.

**OBSOLETE:** TI has discontinued the production of the device.

(2) **RoHS:** TI defines "RoHS" to mean semiconductor products that are compliant with the current EU RoHS requirements for all 10 RoHS substances, including the requirement that RoHS substance do not exceed 0.1% by weight in homogeneous materials. Where designed to be soldered at high temperatures, "RoHS" products are suitable for use in specified lead-free processes. TI may reference these types of products as "Pb-Free".

**RoHS Exempt:** TI defines "RoHS Exempt" to mean products that contain lead but are compliant with EU RoHS pursuant to a specific EU RoHS exemption.

**Green:** TI defines "Green" to mean the content of Chlorine (Cl) and Bromine (Br) based flame retardants meet JS709B low halogen requirements of <=1000ppm threshold. Antimony trioxide based flame retardants must also meet the <=1000ppm threshold requirement.

(3) MSL, Peak Temp. - The Moisture Sensitivity Level rating according to the JEDEC industry standard classifications, and peak solder temperature.

(4) There may be additional marking, which relates to the logo, the lot trace code information, or the environmental category on the device.

(5) Multiple Device Markings will be inside parentheses. Only one Device Marking contained in parentheses and separated by a "~" will appear on a device. If a line is indented then it is a continuation of the previous line and the two combined represent the entire Device Marking for that device.

<sup>(6)</sup> Lead finish/Ball material - Orderable Devices may have multiple material finish options. Finish options are separated by a vertical ruled line. Lead finish/Ball material values may wrap to two lines if the finish value exceeds the maximum column width.

**Important Information and Disclaimer:** The information provided on this page represents TI's knowledge and belief as of the date that it is provided. TI bases its knowledge and belief on information provided by third parties, and makes no representation or warranty as to the accuracy of such information. Efforts are underway to better integrate information from third parties. TI has taken and continues to take reasonable steps to provide representative and accurate information but may not have conducted destructive testing or chemical analysis on incoming materials and chemicals. TI and TI suppliers consider certain information to be proprietary, and thus CAS numbers and other limited information may not be available for release.

In no event shall TI's liability arising out of such information exceed the total purchase price of the TI part(s) at issue in this document sold by TI to Customer on an annual basis.

**TAPE AND REEL INFORMATION**

**QUADRANT ASSIGNMENTS FOR PIN 1 ORIENTATION IN TAPE**

\*All dimensions are nominal

Device	Package Type	Package Drawing	Pins	SPQ	Reel Diameter (mm)	Reel Width W1 (mm)	A0 (mm)	B0 (mm)	K0 (mm)	P1 (mm)	W (mm)	Pin1 Quadrant
INA105KU/2K5	SOIC	D	8	2500	330.0	12.4	6.4	5.2	2.1	8.0	12.0	Q1

**TAPE AND REEL BOX DIMENSIONS**

\*All dimensions are nominal

Device	Package Type	Package Drawing	Pins	SPQ	Length (mm)	Width (mm)	Height (mm)
INA105KU/2K5	SOIC	D	8	2500	356.0	356.0	35.0



**TUBE**

\*All dimensions are nominal

Device	Package Name	Package Type	Pins	SPQ	L (mm)	W (mm)	T (μm)	B (mm)
INA105AM	LMC	TO-CAN	8	1	532.13	21.59	889	NA
INA105BM	LMC	TO-CAN	8	1	532.13	21.59	889	NA
INA105KP	P	PDIP	8	50	506	13.97	11230	4.32
INA105KPG4	P	PDIP	8	50	506	13.97	11230	4.32
INA105KU	D	SOIC	8	75	506.6	8	3940	4.32
INA105KUE4	D	SOIC	8	75	506.6	8	3940	4.32

## IMPORTANT NOTICE AND DISCLAIMER

TI PROVIDES TECHNICAL AND RELIABILITY DATA (INCLUDING DATA SHEETS), DESIGN RESOURCES (INCLUDING REFERENCE DESIGNS), APPLICATION OR OTHER DESIGN ADVICE, WEB TOOLS, SAFETY INFORMATION, AND OTHER RESOURCES "AS IS" AND WITH ALL FAULTS, AND DISCLAIMS ALL WARRANTIES, EXPRESS AND IMPLIED, INCLUDING WITHOUT LIMITATION ANY IMPLIED WARRANTIES OF MERCHANTABILITY, FITNESS FOR A PARTICULAR PURPOSE OR NON-INFRINGEMENT OF THIRD PARTY INTELLECTUAL PROPERTY RIGHTS.

These resources are intended for skilled developers designing with TI products. You are solely responsible for (1) selecting the appropriate TI products for your application, (2) designing, validating and testing your application, and (3) ensuring your application meets applicable standards, and any other safety, security, regulatory or other requirements.

These resources are subject to change without notice. TI grants you permission to use these resources only for development of an application that uses the TI products described in the resource. Other reproduction and display of these resources is prohibited. No license is granted to any other TI intellectual property right or to any third party intellectual property right. TI disclaims responsibility for, and you will fully indemnify TI and its representatives against, any claims, damages, costs, losses, and liabilities arising out of your use of these resources.

TI's products are provided subject to [TI's Terms of Sale](#) or other applicable terms available either on [ti.com](https://www.ti.com) or provided in conjunction with such TI products. TI's provision of these resources does not expand or otherwise alter TI's applicable warranties or warranty disclaimers for TI products.

TI objects to and rejects any additional or different terms you may have proposed.

Mailing Address: Texas Instruments, Post Office Box 655303, Dallas, Texas 75265  
Copyright © 2023, Texas Instruments Incorporated