

Small Plastic Package, Dual SPDT Analog Switch

Features

- ➔ CMOS Technology for Bus and Analog Applications
- ➔ Low On-Resistance: 0.45Ω
- ➔ Wide V_{DD} Range: 1.8V to 4.2V
- ➔ Rail-to-Rail Signal Range
- ➔ High Off Isolation: -83dB @ 100kHz
- ➔ Crosstalk Rejection Reduces Signal Distortion: -108dB @ 100kHz
- ➔ Break-Before-Make Switching
- ➔ Extended Industrial Temperature Range: -40°C to 85°C
- ➔ ESD protection : 4kV(HBM)
- ➔ Packaging (Pb-free & Green):
 - -10-pin UQFN (ZM), 1.4mm x 1.8mm

Applications

- ➔ Cell Phones
- ➔ PDAs
- ➔ MP3 Players
- ➔ Portable Instrumentation
- ➔ Computer Peripherals
- ➔ Speaker Headset Switching
- ➔ Power Routing
- ➔ Relay Replacement
- ➔ Audio and Video Signal Routing
- ➔ PCMCIA Cards
- ➔ Modems

Pin Configuration (Top view)

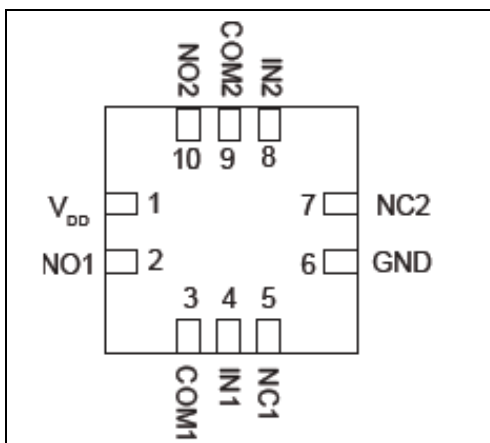

Description

PI3A223 is a dual fast single-pole double throw (SPDT) CMOS switch. It can be used as an analog switch or as a low-delay bus switch. Specified over a wide operating power supply voltage, 1.8V to 4.2V, the PI3A223 has an On-Resistance of 0.45Ω at +4.2V. Break-before-make switching prevents both switches being enabled simultaneously. This eliminates signal disruption during switching.

Block Diagram

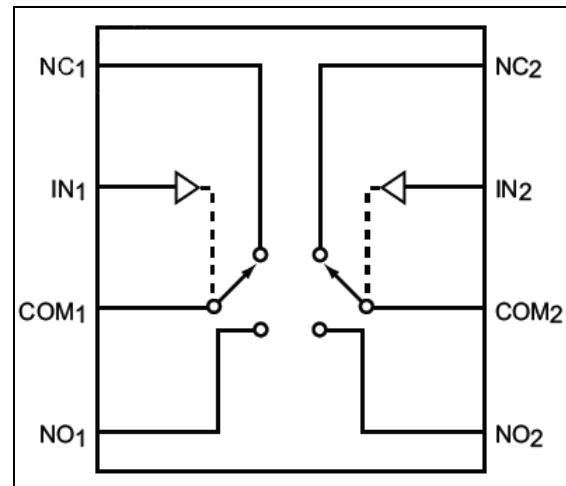

Pin Description

Pin#	Name	Description
1	V _{DD}	Positive Power Supply
2	NO1	Data Port (Normally open)
3	COM1	Common Output / Data Port
4	IN1	Logic Control
5	NC1	Data Port (Normally closed)
6	GND	Ground
7	NC2	Data Port (Normally closed)
8	IN2	Logic Control
9	COM2	Common Output / Data Port
10	NO2	Data Port (Normally open)

Function Table

Logic Input (IN _x)	Function
0	NC _x Connected to COM _x
1	NO _x Connected to COM _x

Note: x = 1 or 2

Maximum Ratings

Storage Temperature.....	-65°C to +150°C
Ambient Temperature with Power Applied.....	-40°C to +85°C
Supply Voltage V_{DD}	-0.5V to +4.6V
Control Input Voltage V_{INx}	0V to +4.6V
DC Input Voltage V_{INPUT}	-0.5V to +4.6V
Continuous Current NO_NC_COM_.....	±300mA
Peak Current NO_NC_COM_	
(pulsed at 1ms 50% duty cycle)	±400mA
Peak Current NO_NC_COM_	
(pulsed at 1ms 10% duty cycle)	±500mA
ESD(HBM)	4kV

Note:

Stresses greater than those listed under MAXIMUM RATINGS may cause permanent damage to the device. This is a stress rating only and functional operation of the device at these or any other conditions above those indicated in the operational sections of this specification is not implied. Exposure to absolute maximum rating conditions for extended periods may affect reliability. The input and output negative voltage ratings may be exceeded if the input and output diode current ratings are observed. Control input must be held HIGH or LOW; it must not float.

Recommended Operating Conditions

Symbol	Parameter	Conditions	Min.	Typ.	Max.	Unit
V_{DD}	Operating Voltage	-	1.8	-	4.2	V
V_{IN}	Control Input Voltage	-	0	-	V_{DD}	V
V_{INPUT}	Switch Input Voltage	-	-0.3	-	4.2	V
T_A	Operating Temperature	-	-40	25	85	°C
t_r, t_f	Input Rise and Fall Time	-	0	-	10	ns/V

DC Electrical Characteristics

+3.0V Supply ($V_{DD} = 2.7V$ to $3.6V$, $V_{IH} = +1.6V$, $V_{IL} = +0.4V$, $T_A = -40^\circ C$ to $85^\circ C$, unless otherwise noted. Typical values are at $3.0V$ and $+25^\circ C$.)

Parameter	Symbol	Test Conditions	TEMP	Min.	Typ.	Max.	Units
ANALOG SWITCH							
Analog Signal Range	V_{NO}, V_{NC}, V_{COM}	-	-40 °C to 85 °C	0	-	V_{DD}	V
On-Resistance	R_{ON}	$V_{DD} = 2.7V, I_{COM} = 100mA, V_{NO}$ or $V_{NC} = 1V, \text{Test Circuit 1}$	+25°C	-	0.55	0.9	Ω
			-40 °C to 85 °C	-	0.55	1	
On-Resistance Match Between Channels	ΔR_{ON}	$V_{DD} = 2.7V, I_{COM} = 100mA, V_{NO}$ or $V_{NC} = 1V, \text{Test Circuit 1}$	+25°C	-	0.05	0.22	Ω
			-40 °C to 85 °C	-	0.05	0.25	
On-Resistance Flatness	R_{ONF}	$V_{DD} = 2.7V, I_{COM} = 100mA, V_{NO}$ or $V_{NC} = 1V, 2.5V, \text{Test Circuit 1}$	+25°C	-	0.1	0.22	Ω
			-40 °C to 85 °C	-	0.1	0.26	
Source Off Leakage Current	$I_{OFF(NO)}$ or $I_{OFF(NC)}$	$V_{DD} = 3.6V, V_{NO}$ or $V_{NC} = 3.3V/0.3V, V_{COM} = 0.3V/3.3V$	-40 °C to 85 °C	-	-	1	μA
Channel On Leakage Current	$I_{NC(ON)}, I_{NO(ON)}, I_{COM(ON)}$	$V_{DD} = 3.6V, V_{NO}$ or $V_{NC} = 3V/0.3V, V_{COM} = 3V/0.3V, \text{ or floating}$	-40 °C to 85 °C	-	-	1	
DIGITAL INPUTS							
Input Logic High	V_{IH}	-	-40 °C to 85 °C	1.2	-	-	V
Input Logic Low	V_{IL}	-	-40 °C to 85 °C	-	-	0.5	
IN Input Leakage Current	I_{IN}	$V_{DD} = 2.7V, V_{IN} = 0$ or $2.7V$	-40 °C to 85 °C	-	-	1	μA
DYNAMIC CHARACTERISTICS							
Turn-On Time	t_{ON}	$V_{IH} = 1.5V, V_{IL} = 0V, \text{ See Test Circuit Figure 2.}$	+25°C	-	16	-	ns
Turn-Off Time	t_{OFF}	$V_{IH} = 1.5V, V_{IL} = 0V, \text{ See Test Circuit Figure 2.}$	+25°C	-	60	-	ns
Break-Before-Make	t_D	$V_{IH} = 1.5V, V_{IL} = 0V,$	+25°C	-	10	-	ns

Parameter	Symbol	Test Conditions	TEMP	Min.	Typ.	Max.	Units	
Delay		See Test Circuit Figure 3.						
COM-NC/NO and NC-NO Isolations	O_{ISO}	$V_{BIAS}=1.5V, V_{IN}=0dBm, V_{IH}=1.5V, V_{IL}=0V$. See Test Circuit Figure 4 & Figure 5.	100kHz	+25°C	-	-81	-	dB
			1MHz	+25°C	-	-61	-	
			10MHz	+25°C	-	-39	-	
Channel-to-Channel Crosstalk	X_{TALKD}	$V_{BIAS} = 1.5V, V_{DD}=0dBm, V_{IH}=1.5V, V_{IL}=0V$ See Test Circuit Figure 6.	100kHz	+25°C	-	-108	-	dB
			1MHz	+25°C	-	-110	-	
			10MHz	+25°C	-	-90	-	
3dB Bandwidth	f_{3dB}	$V_{BIAS} = 1.5V, V_{IN}=0dBm, V_{IH}=1.5V, V_{IL}=0V$. See Test Circuit Figure 7.	+25°C	-	79	-	MHz	
Charge Injection Select Input to Common I/O	Q	$V_{IN} = GND, R_S = 0, C_L = 1nF, V_{IH}=1.5V, V_{IL}=0V$ See Test Circuit Figure 8.	+25°C	-	35	-	pC	

+4.2V Supply ($V_{DD} = 4.2V, T_A = -40^\circ C$ to $85^\circ C$, unless otherwise noted. Typical values are at 4.2V and +25°C.)

Parameter	Symbol	Test Conditions	TEMP	Min.	Typ.	Max.	Units	
ANALOG SWITCH								
Analog Signal Range	V_{NO}, V_{NC}, V_{COM}	-	-40 °C to 85 °C	0	-	V_{DD}	V	
On-Resistance	R_{ON}	$V_{DD} = 4.2V, I_{COM} = 100mA, V_{NO}$ or $V_{NC}=1V$, Test Circuit 1	+25°C	-	0.45	0.75	Ω	
			-40 °C to 85 °C	-	0.45	0.85		
On-Resistance Match Between Channels	ΔR_{ON}	$V_{DD} = 4.2V, I_{COM} = 100mA, V_{NO}$ or $V_{NC}=1V$, Test Circuit 1	+25°C	-	0.05	0.18	Ω	
			-40 °C to 85 °C	-	0.05	0.23		
On-Resistance Flatness	R_{ONF}	$V_{DD} = 4.2V, I_{COM} = 100mA, V_{NO}$ or $V_{NC} = 1V, 2.5V$, Test Circuit 1	+25°C	-	0.1	0.22	Ω	
			-40 °C to 85 °C	-	0.1	0.26		
Source Off Leakage Current	$I_{OFF(NO)}$ or $I_{OFF(NC)}$	$V_{DD}= 4.2V, V_{NO}$ or $V_{NC} = 3.3V/0.3V, V_{COM} = 0.3V/3V$	-40 °C to 85 °C	-	-	1	μA	
Channel On Leakage Current	$I_{NC(ON)}, I_{NO(ON)}, I_{COM(ON)}$	$V_{DD} = 4.2V, V_{NO}$ or $V_{NC} = 3V/0.3V, V_{COM} = 3V/0.3V$, or floating	-40 °C to 85 °C	-	-	1		
DIGITAL INPUTS								
Input Logic High	V_{IH}	-	-40 °C to 85 °C	1.2	-	-	V	
Input Logic Low	V_{IL}	-	-40 °C to 85 °C	-	-	0.5		
IN Input Leakage Current	I_{IN}	$V_{DD} = 4.2V, V_{IN}=0$ or $4.2V$	-40 °C to 85 °C	-	-	1	μA	
DYNAMIC CHARACTERISTICS								
Turn-On Time	t_{ON}	$V_{IH}=3V, V_{IL}=0V$, See Test Circuit Figure 2.	+25°C	-	13	-	ns	
Turn-Off Time	t_{OFF}	$V_{IH}=3V, V_{IL}=0V$, See Test Circuit Figure 2.	+25°C	-	38	-	ns	
Break-Before-Make Delay	t_D	$V_{IH}=3V, V_{IL}=0V$, See Test Circuit Figure 3.	+25°C	-	8	-	ns	
COM-NC/NO and NC-NO Isolations	O_{ISO}	$V_{BIAS} = 2.1V, V_{IN}=0dBm, V_{IH}=3V, V_{IL}=0V$. See Test Circuit Figure 4 & Figure 5.	100kHz	+25°C	-	-83	-	dB
			1MHz	+25°C	-	-61	-	
			10MHz	+25°C	-	-39	-	
Channel-to-channel Crosstalk	X_{TALK}	$V_{BIAS} = 2.1V, V_{IN}=0dBm, V_{IH}=3V, V_{IL}=0V$ See Test Circuit	100kHz	+25°C	-	-108	-	dB
			1MHz	+25°C	-	-110	-	

Parameter	Symbol	Test Conditions	TEMP	Min.	Typ.	Max.	Units
		Figure 6.	10MHz	+25°C	-	-90	-
3dB Bandwidth	f_{3dB}	$V_{BIAS} = 2.1V, V_{IN}=0dBm, V_{IH}=3V, V_{IL}=0V$. See Test Circuit Figure 7.	+25°C	-	84	-	MHz
Charge Injection Select Input to Common I/O	Q	$V_{IN} = GND, R_S = 0, C_L = 1nF, V_{IH}=3V, V_{IL}=0V$ See Test Circuit Figure 8.	+25°C	-	50	-	pC
POWER REQUIREMENTS							
Power Supply Range	V_{DD}	-	-40 °C to 85 °C	1.8	-	4.2	V
Power Supply Current	I_{CC}	$V_{DD}=4.2V, V_{IN}=0V$ or V_{DD}	-40 °C to 85 °C	-	-	1	μA

Capacitance

Parameter	Symbol	Test Conditions	Min.	Typ.	Max.	Units
NC Off Capacitance	$C_{NC(OFF)}$	$f = 1MHz$, See Test Circuit Figure 9.	-	20	-	pF
NO Off Capacitance	$C_{NO(OFF)}$	$f = 1MHz$, See Test Circuit Figure 9.	-	20	-	
NC On Capacitance	$C_{NC(ON)}$	$f = 1MHz$, See Test Circuit Figure 10.	-	55	-	
NO On Capacitance	$C_{NO(ON)}$	$f = 1MHz$, See Test Circuit Figure 10.	-	55	-	

Test Circuits and Timing Diagrams

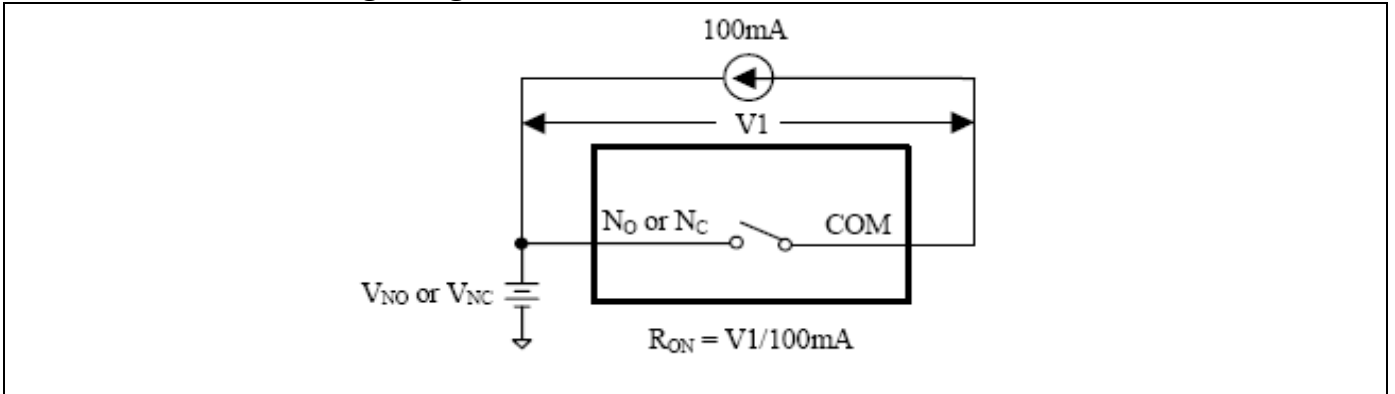

Figure 1. On Resistance

Notes:

1. Unused input (NC or NO) must be grounded.

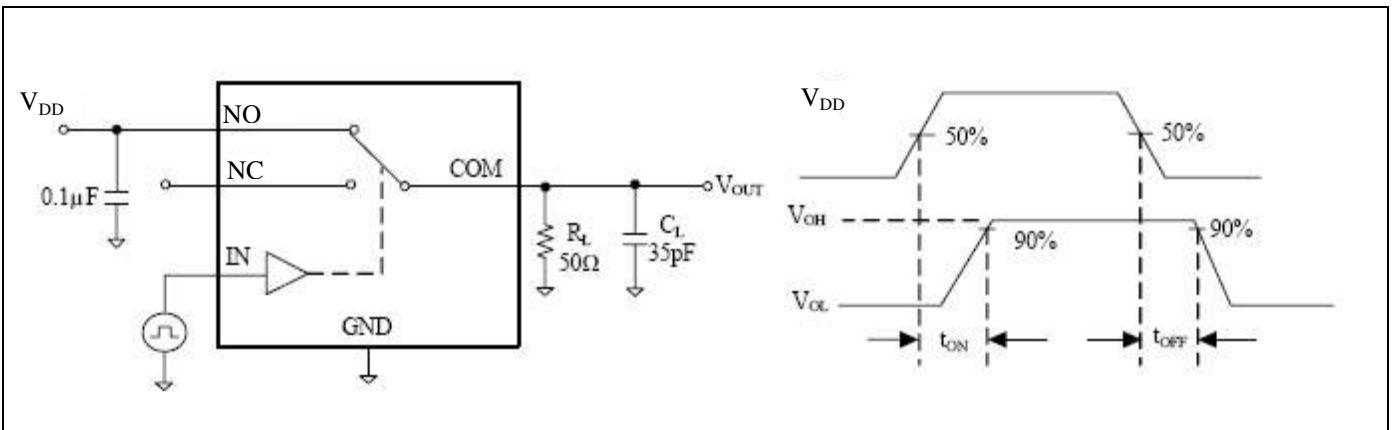

Figure 2. Switching Times

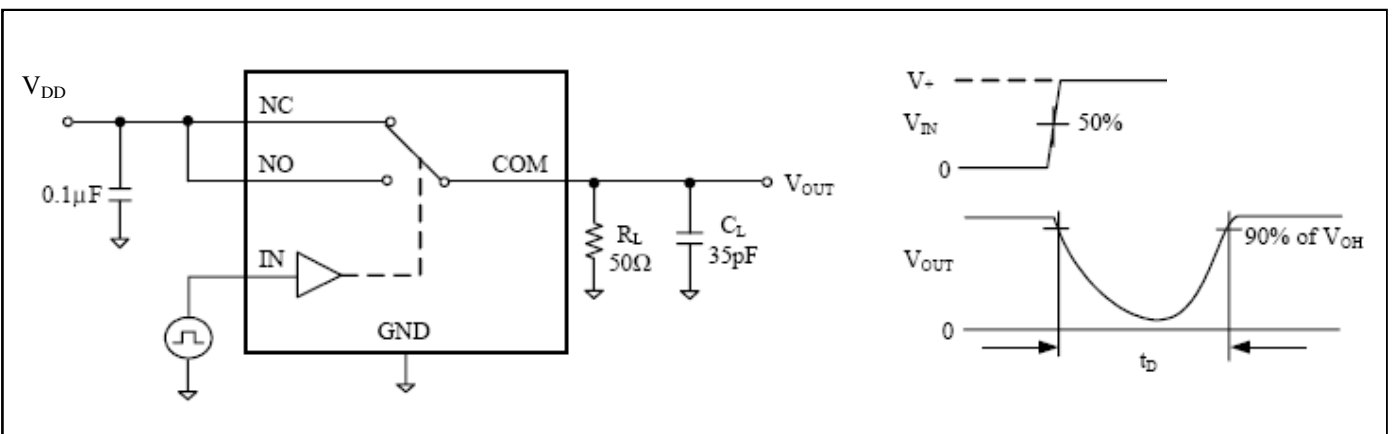

Figure 3. Break Before Make Interval Timing

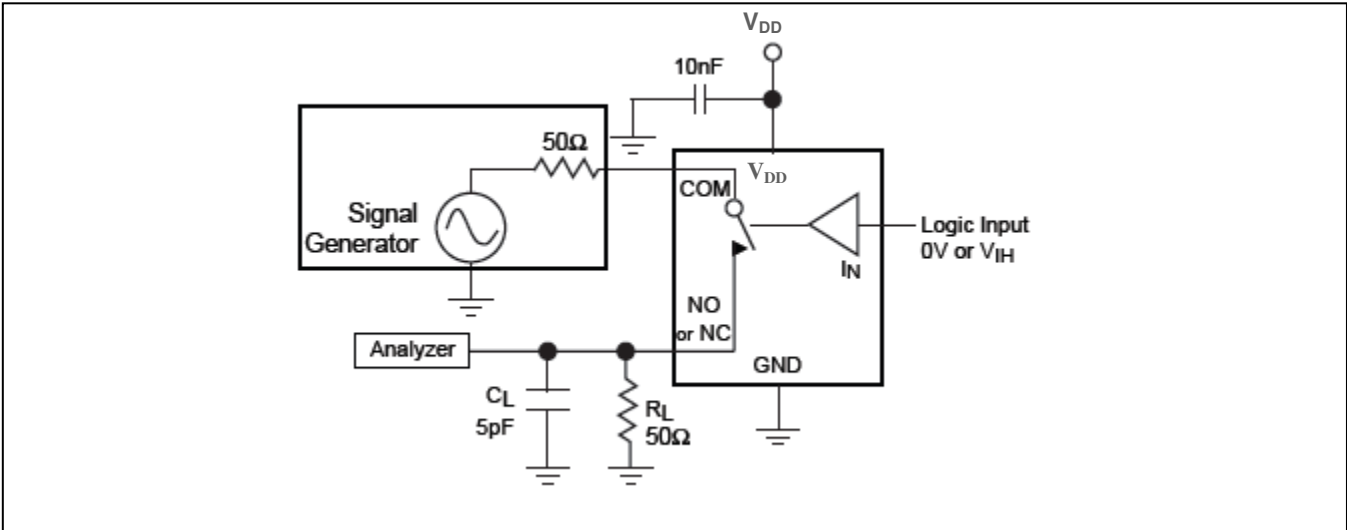

Figure 4. COM-NC/NO Isolation

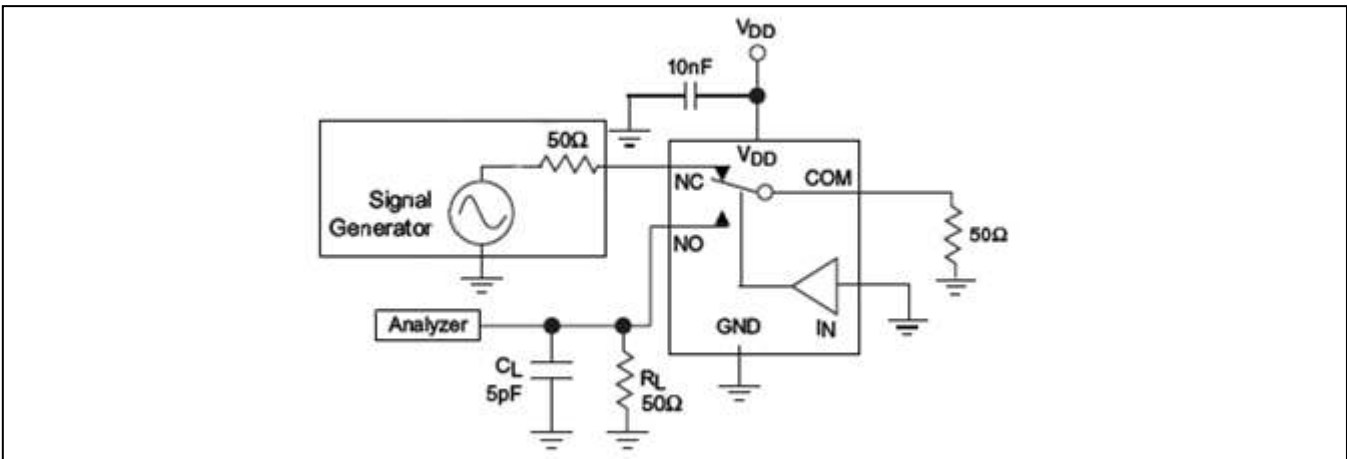

Figure 5. NC-NO Isolation

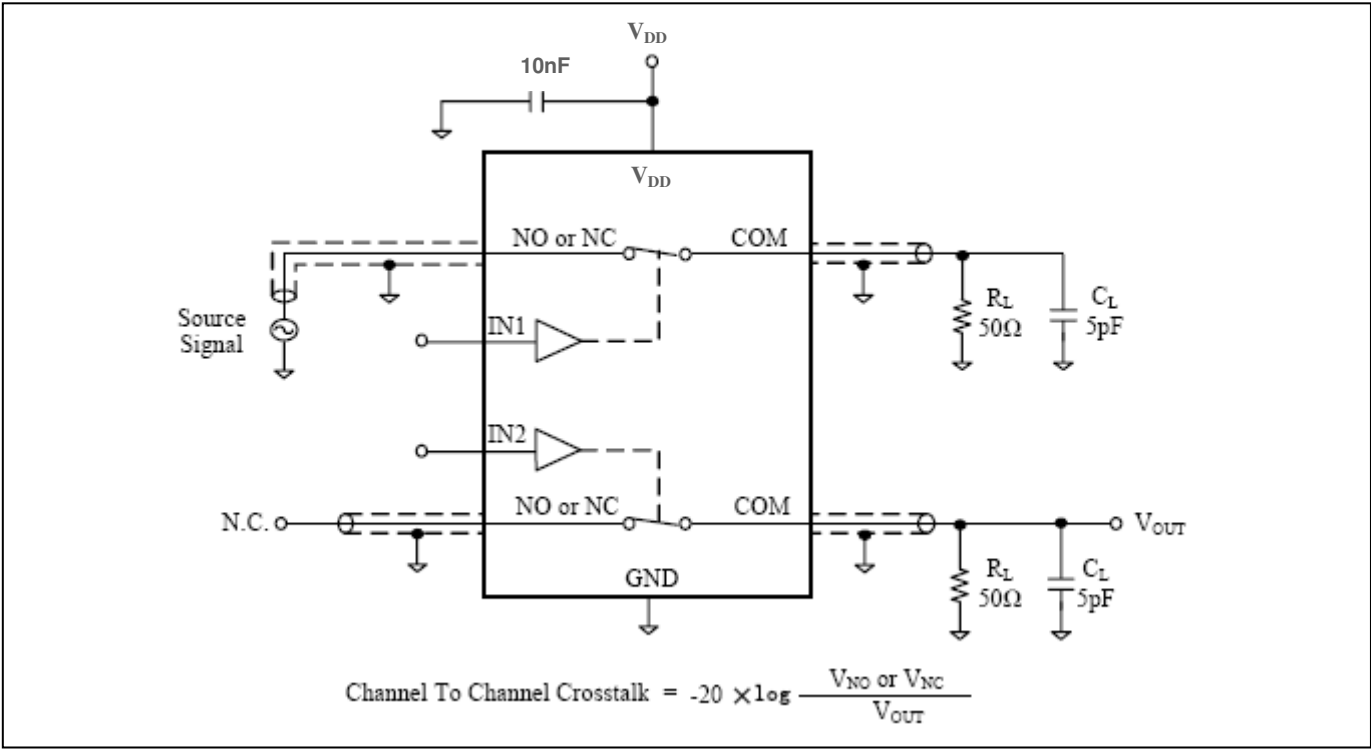

Figure 6. Channel-to-Channel Crosstalk

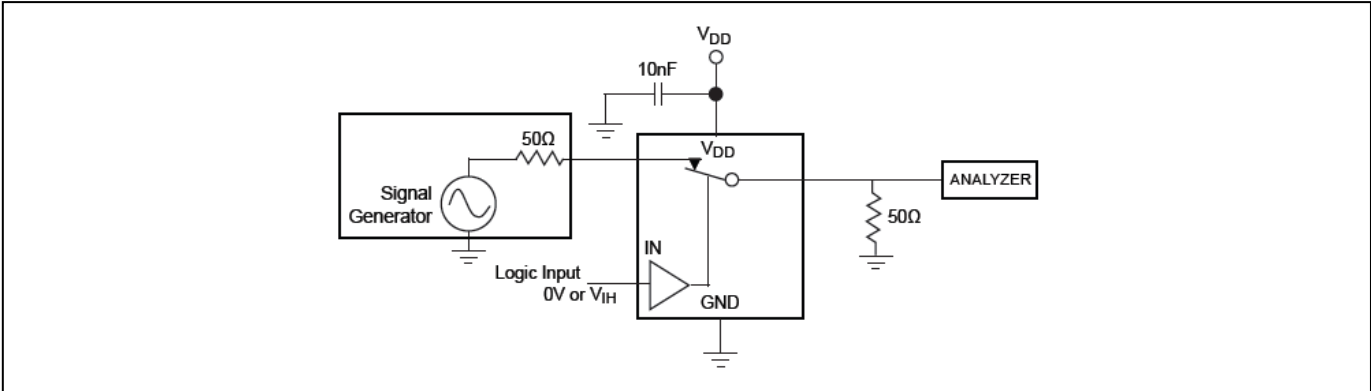

Figure 7. Bandwidth

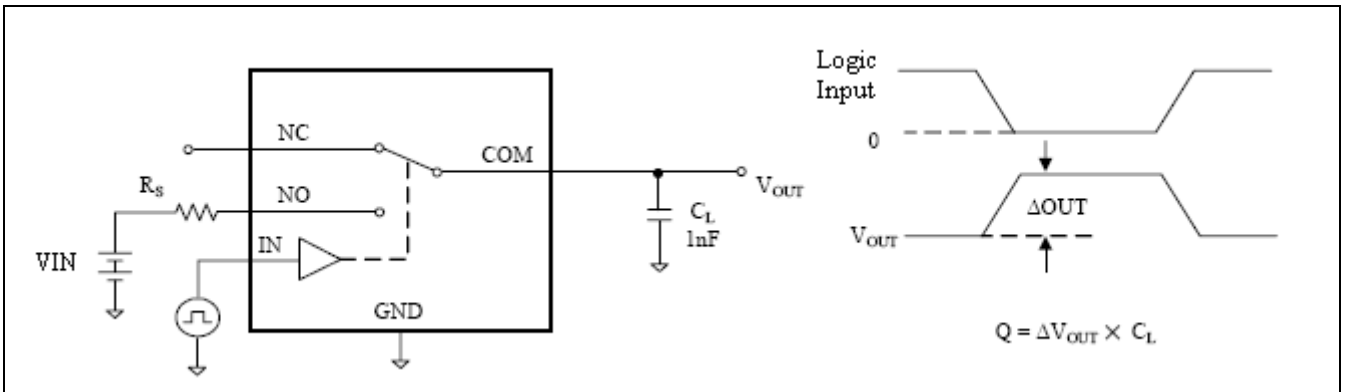

Figure 8. Charge Injection

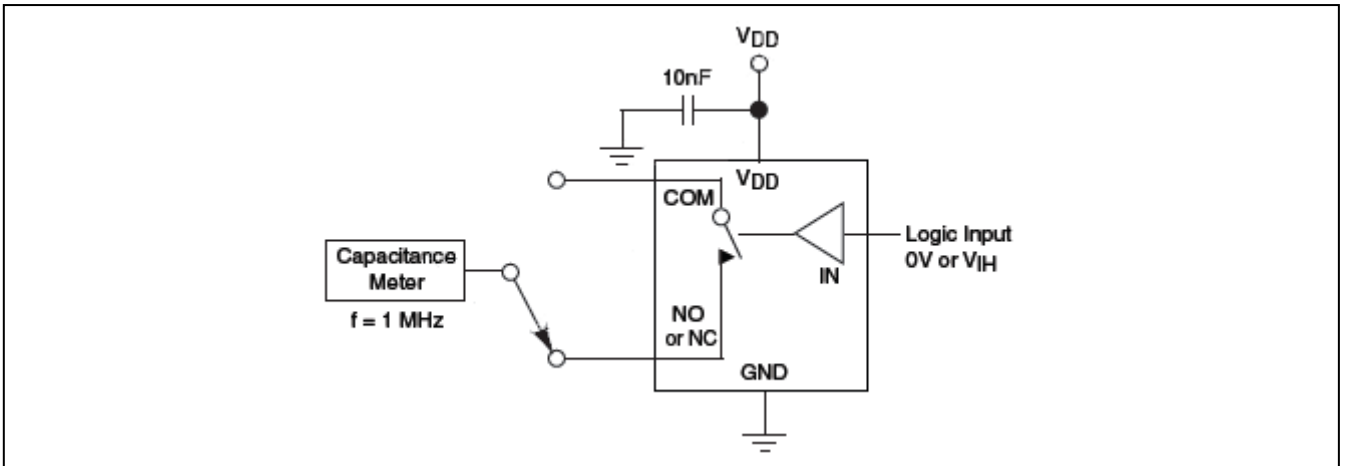

Figure 9. Channel Off Capacitance

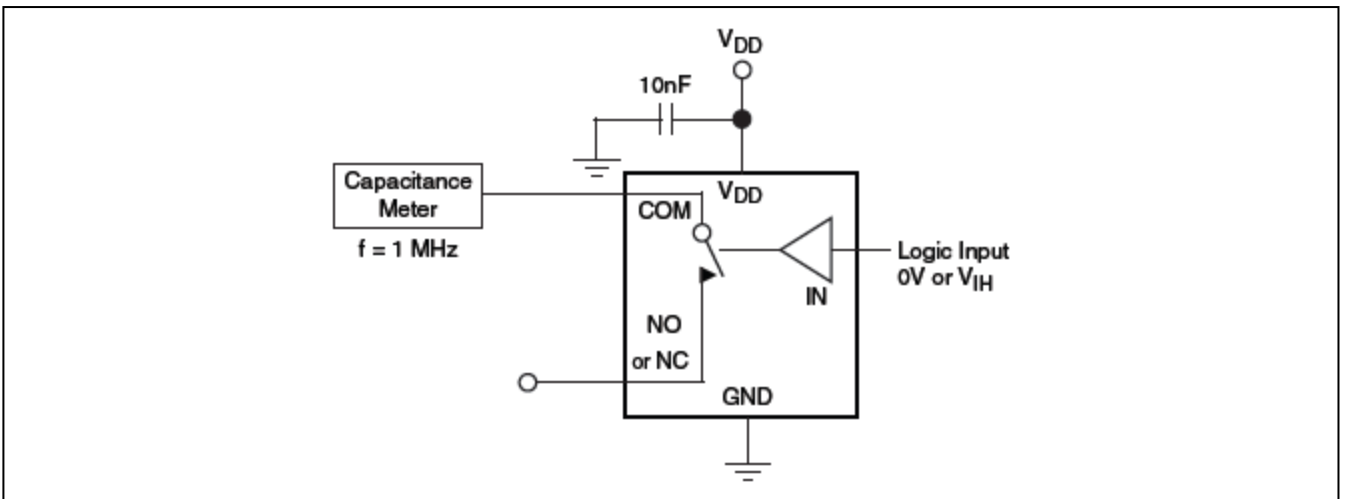
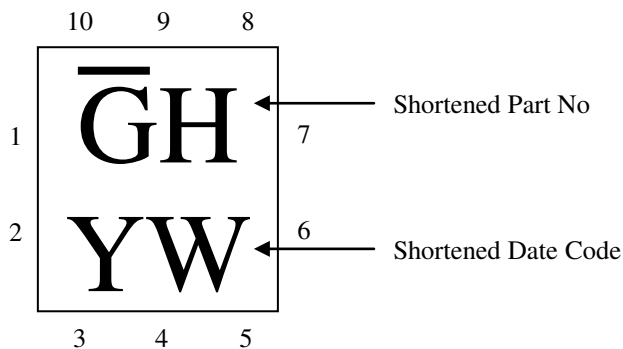

Figure 10. Channel On Capacitance

Part Marking

ZM Package



Packaging Mechanical
10-UQFN (ZM)

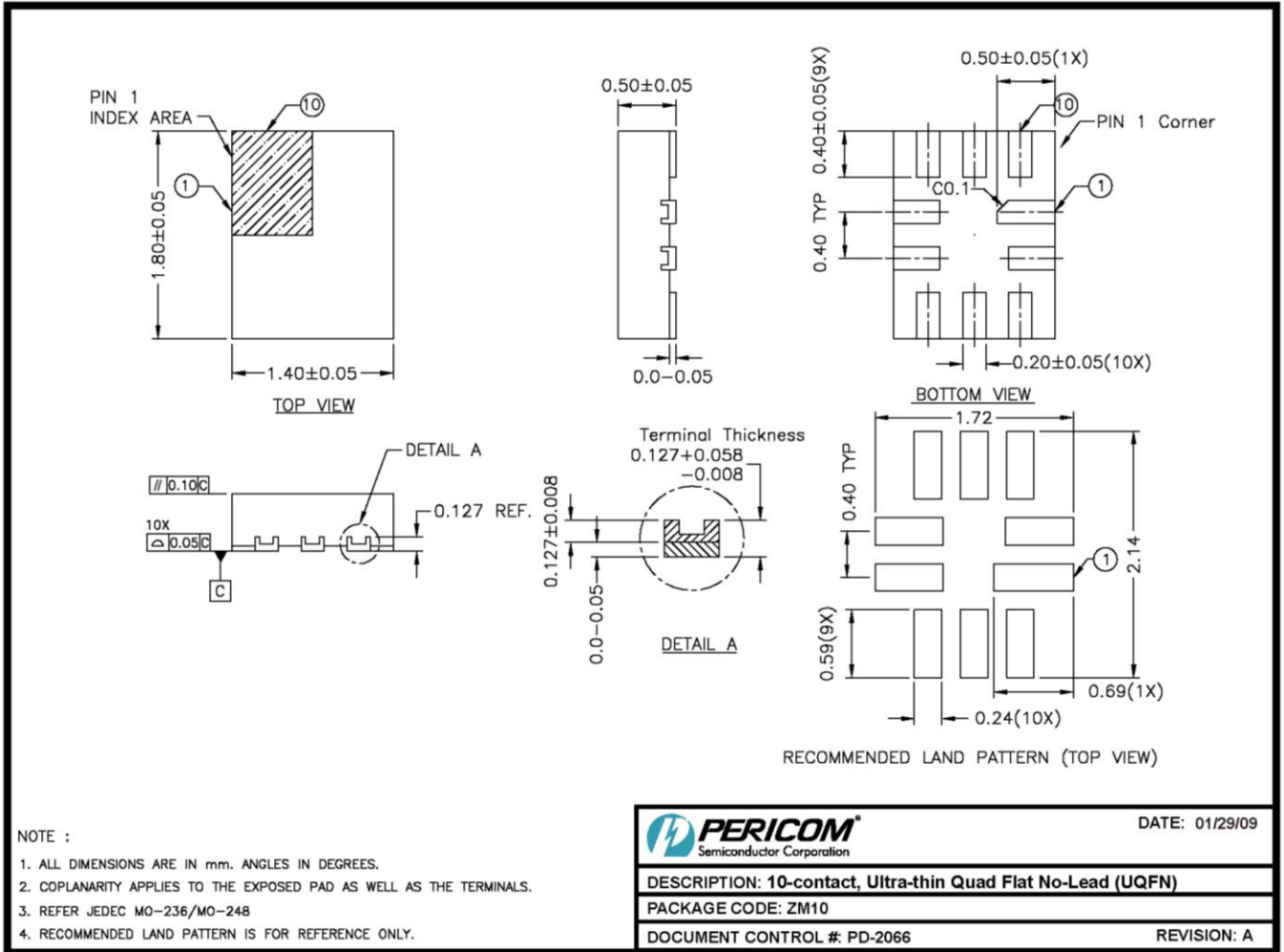

09-0072

For latest package info.

please check: <http://www.diodes.com/design/support/packaging/pericom-packaging/packaging-mechanicals-and-thermal-characteristics/>

Ordering Information

Part Number	Packaging Code	Package Description
PI3A223ZMEX	ZM	10-Contact, Ultra-thin Quad Flat No-Lead (UQFN)

Notes:

- EU Directive 2002/95/EC (RoHS), 2011/65/EU (RoHS 2) & 2015/863/EU (RoHS 3) compliant. All applicable RoHS exemptions applied.
- See <http://www.diodes.com/quality/lead-free/> for more information about Diodes Incorporated's definitions of Halogen- and Antimony-free, "Green" and Lead-free.
- Thermal characteristics can be found on the company web site at www.diodes.com/design/support/packaging/
- E = Pb-free and Green
- X suffix = Tape/Reel

IMPORTANT NOTICE

DIODES INCORPORATED MAKES NO WARRANTY OF ANY KIND, EXPRESS OR IMPLIED, WITH REGARDS TO THIS DOCUMENT, INCLUDING, BUT NOT LIMITED TO, THE IMPLIED WARRANTIES OF MERCHANTABILITY AND FITNESS FOR A PARTICULAR PURPOSE (AND THEIR EQUIVALENTS UNDER THE LAWS OF ANY JURISDICTION).

Diodes Incorporated and its subsidiaries reserve the right to make modifications, enhancements, improvements, corrections or other changes without further notice to this document and any product described herein. Diodes Incorporated does not assume any liability arising out of the application or use of this document or any product described herein; neither does Diodes Incorporated convey any license under its patent or trademark rights, nor the rights of others. Any Customer or user of this document or products described herein in such applications shall assume all risks of such use and will agree to hold Diodes Incorporated and all the companies whose products are represented on Diodes Incorporated website, harmless against all damages.

Diodes Incorporated does not warrant or accept any liability whatsoever in respect of any products purchased through unauthorized sales channel. Should Customers purchase or use Diodes Incorporated products for any unintended or unauthorized application, Customers shall indemnify and hold Diodes Incorporated and its representatives harmless against all claims, damages, expenses, and attorney fees arising out of, directly or indirectly, any claim of personal injury or death associated with such unintended or unauthorized application.

Products described herein may be covered by one or more United States, international or foreign patents pending. Product names and markings noted herein may also be covered by one or more United States, international or foreign trademarks.

This document is written in English but may be translated into multiple languages for reference. Only the English version of this document is the final and determinative format released by Diodes Incorporated.

LIFE SUPPORT

Diodes Incorporated products are specifically not authorized for use as critical components in life support devices or systems without the express written approval of the Chief Executive Officer of Diodes Incorporated. As used herein:

- A. Life support devices or systems are devices or systems which:
1. are intended to implant into the body, or
 2. support or sustain life and whose failure to perform when properly used in accordance with instructions for use provided in the labeling can be reasonably expected to result in significant injury to the user.
- B. A critical component is any component in a life support device or system whose failure to perform can be reasonably expected to cause the failure of the life support device or to affect its safety or effectiveness.

Customers represent that they have all necessary expertise in the safety and regulatory ramifications of their life support devices or systems, and acknowledge and agree that they are solely responsible for all legal, regulatory and safety-related requirements concerning their products and any use of Diodes Incorporated products in such safety-critical, life support devices or systems, notwithstanding any devices- or systems-related information or support that may be provided by Diodes Incorporated. Further, Customers must fully indemnify Diodes Incorporated and its representatives against any damages arising out of the use of Diodes Incorporated products in such safety-critical, life support devices or systems.

Copyright © 2016, Diodes Incorporated
www.diodes.com