



# SPECIFICATION FOR AUTOMOTIVE SPEAKER

TOTAL PAGE	08	<a href="http://www.bestargroups.com">www.bestargroups.com</a>	RoHS
------------	----	--	------

Customer		Model Name	BMS36-11-50H5.0W80JST LF
Customer P/N		Product No.	132330
Date	31 Jul.13	Issue No.	BS/TES01.1130B
Page	01 of 08	Issue Date	2013.07.31

## Approval:

- 1.Characteristic
- 2.Dimension
- 3.Reliability Test
- 4.Packing
- 5.History change record

Drawn by	Checked by	Approved by	Customer approved

## **BESTAR ACOUSTICS CO.,LTD**

No.199 HuangHe West Road,New district,ChangZhou,JiangSu Province,P.R.China

**Tel:** +86 519 88222567      **Fax:** +86 519 88222551

**E-mail:**[wu@be-star.com](mailto:wu@be-star.com)      **<http://www.bestargroups.com>**

# BMS36-11-50H5.0W80JST LF

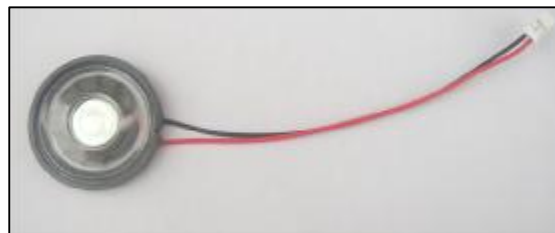

## 1. Characteristic

### 1.1 Electrical and Mechanical Characteristics

No.	Item	Specification
1.	Rated Input Power	0.5W
2.	Maximum Input Power	1W
3.	Resonance Frequency	600 ± 150 Hz
4.	Frequency Response	f0...5000Hz
5.	Deviation	Max.20dB
6.	Magnet	NdFeB Ø 12.5X1.5mm
7.	Impedance(at 1kHz)	50 ohm ± 15%
8.	Output SPL(at 0.5m /1W)	87 ± 3dB(at 1KHz)
9.	Buzzes & Rattles	Must be normal at sine wave 5V
10.	Operating Temperature	-40...+85 °C
11.	Storage Temperature	-40...+85 °C

### 1.2 Test Method

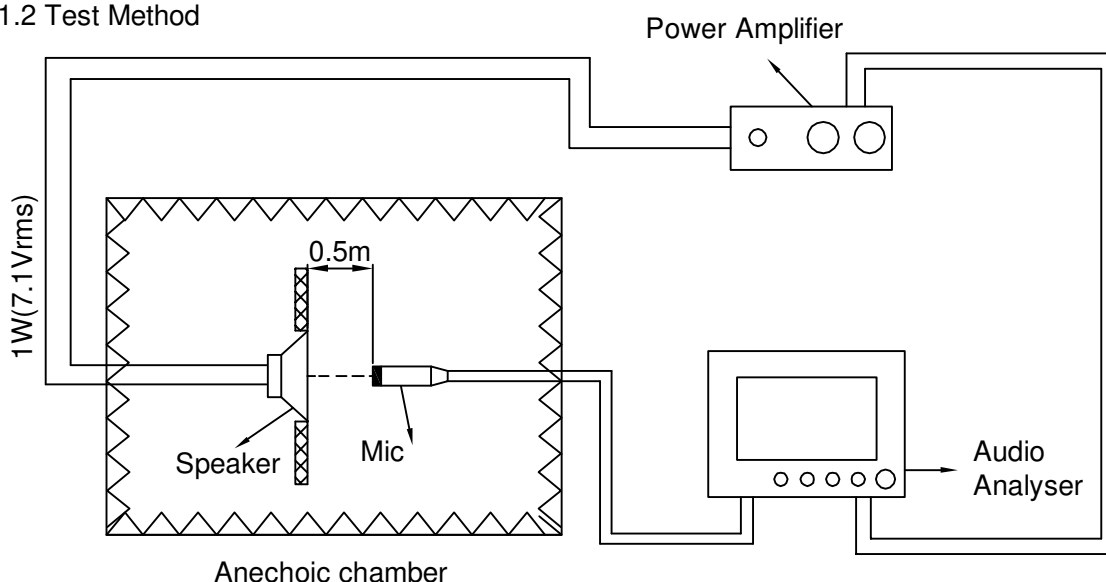

				Date:	2013.07.31	BMS36-11-50H5.0W80JST LF
B	2013.07.31	胡兆俊		Drawn by:	胡兆俊	
A	2012.07.04	莫丽丽		Checked by:	莫丽丽	Speaker
Rev.	Date	Drawn	Note	Approved by:	王平	
BESTAR ACOUSTICS CO.,LTD						DRG NO: BS/TES01.1130B
www.bestargroups.com wu@be-star.com						Page:02 of 08

This print and information there in are proprietary to Be Star Acoustics Co., Ltd. and shall not be used in whole or in part without its written content

# BMS36-11-50H5.0W80JST LF

1.3 Fundamental (only for reference),using sine wave 1W,0.5m test

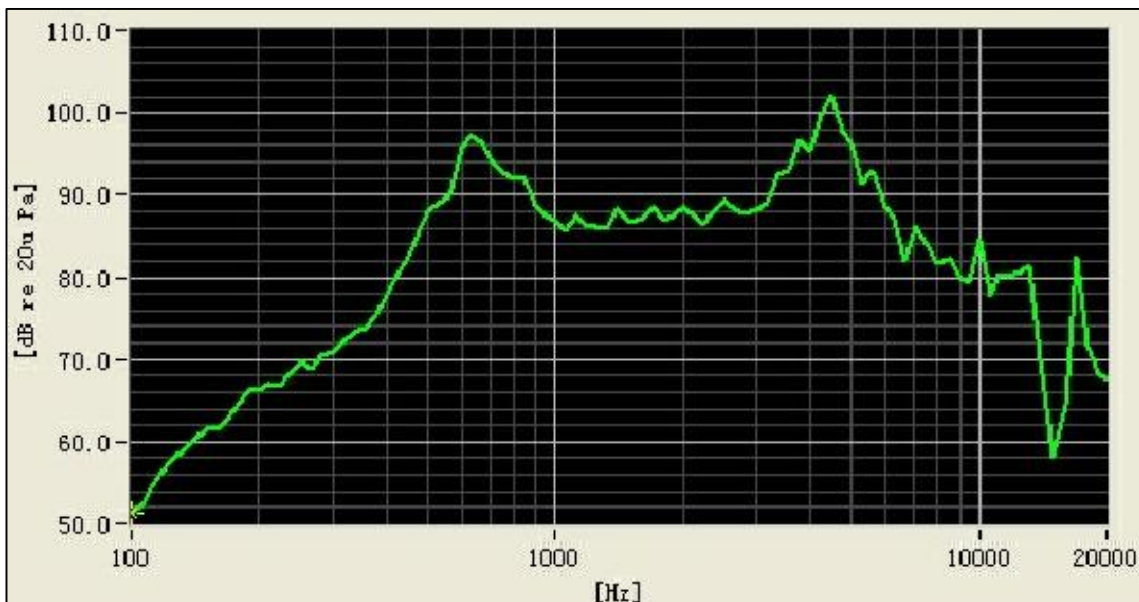

1.4 THD(only for reference)

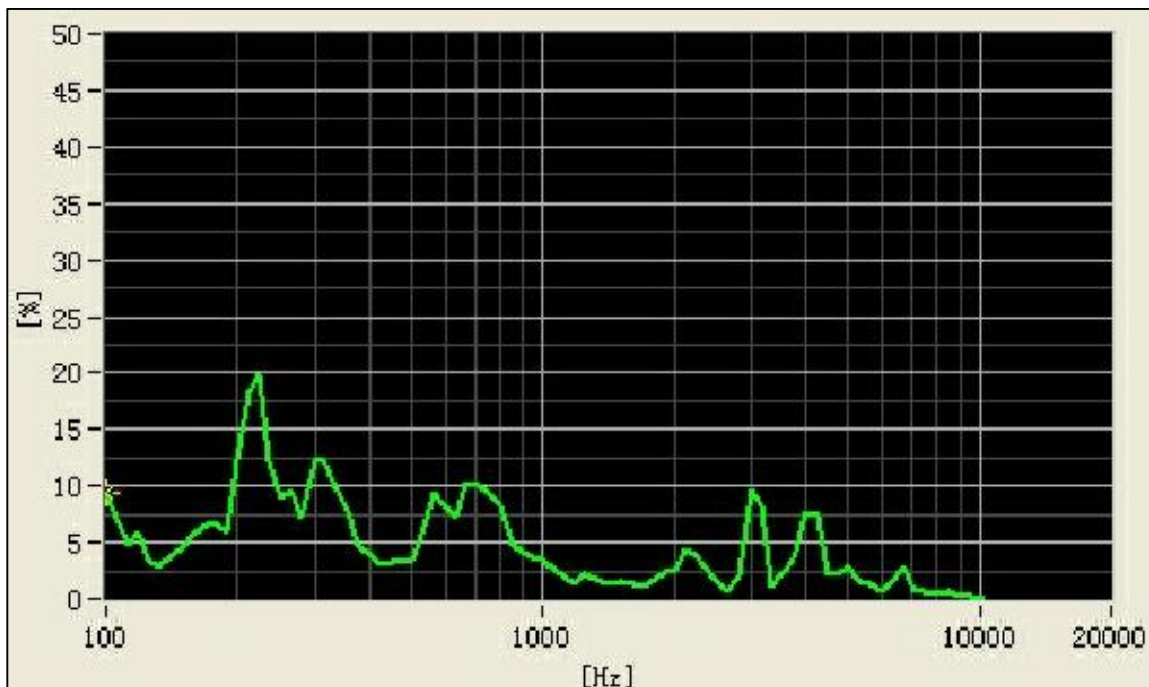

This print and information there in are proprietary to Be Star Acoustics Co., Ltd. and shall not be used in whole or in part without its written content

				Date:	2013.07.31	BMS36-11-50H5.0W80JST LF	
B	2013.07.31	胡兆俊		Drawn by:	胡兆俊		
A	2012.07.04	莫丽丽		Checked by:	莫丽丽	Speaker	
REV.	Date	Drawn	Note	Approved by:	王平		
BESTAR ACOUSTICS CO.,LTD						DRG NO: BS/TES01.1130B	Page:03 of 08
www.bestargroups.com wu@be-star.com							

# BMS36-11-50H5.0W80JST LF

1.5 Impedance(only for reference)

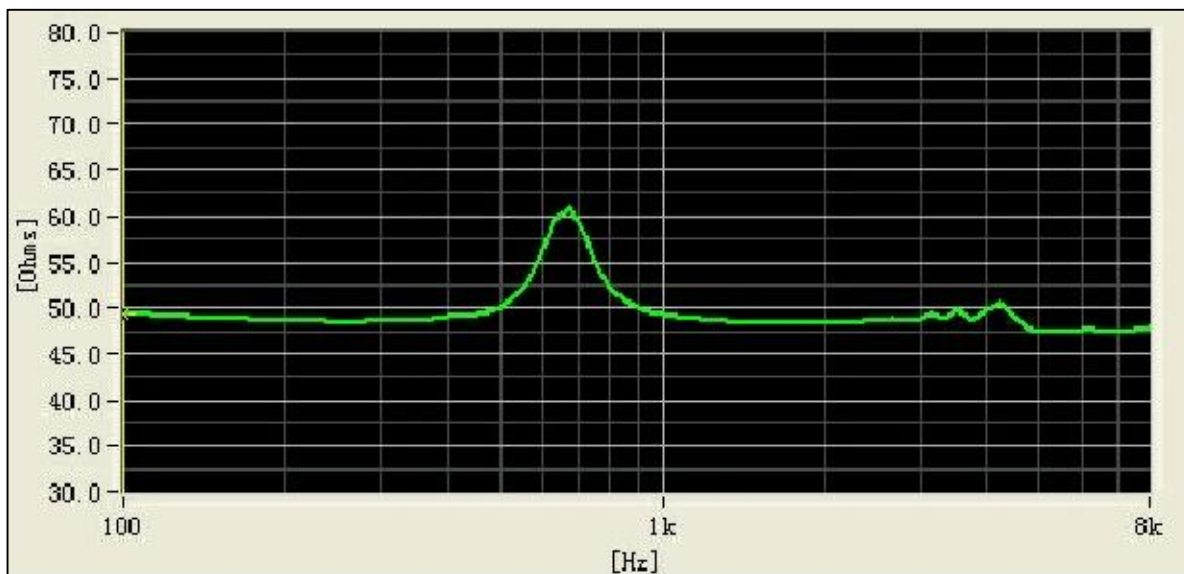

1.6 Rub&buzz(only for reference)

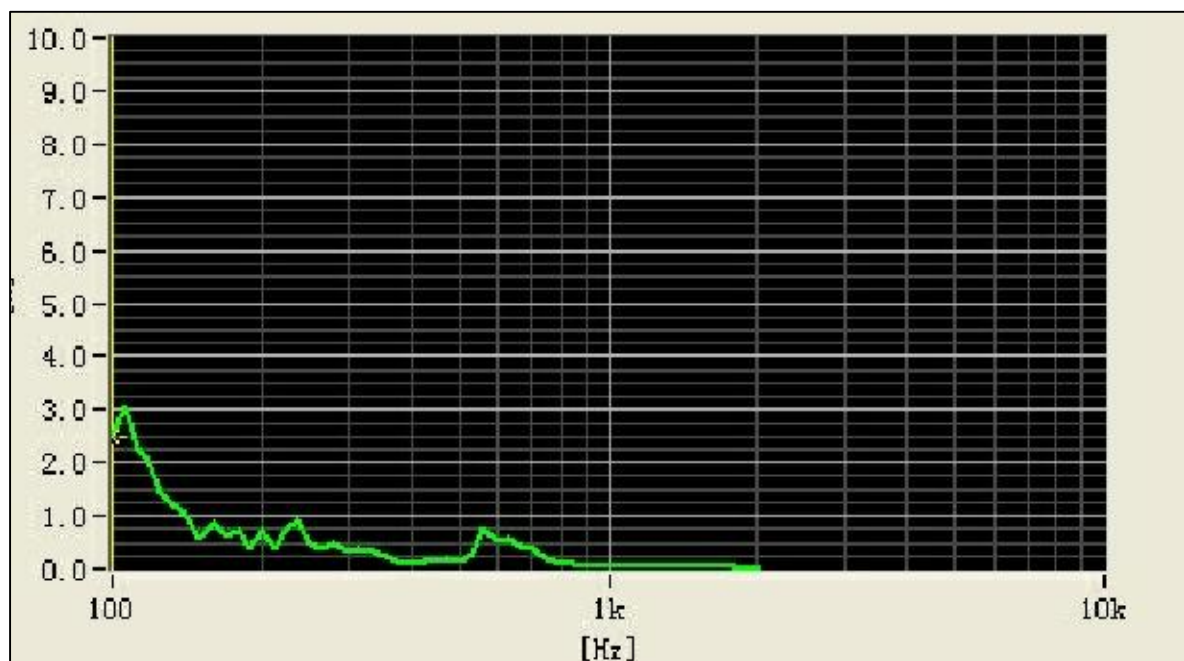

This print and information there in are proprietary to Be Star Acoustics Co., Ltd. and shall not be used in whole or in part without its written content

				Date:	2013.07.31	BMS36-11-50H5.0W80JST LF
B	2013.07.31	胡兆俊		Drawn by:	胡兆俊	
A	2012.07.04	莫丽丽		Checked by:	莫丽丽	Speaker
REV.	Date	Drawn	Note	Approved by:	王平	
BESTAR ACOUSTICS CO.,LTD						DRG NO: BS/TES01.1130B
<a href="http://www.bestargroups.com">www.bestargroups.com</a> <a href="mailto:wu@be-star.com">wu@be-star.com</a>						Page:04 of 08

# BMS36-11-50H5.0W80JST LF

## 2. Dimension Unit:mm

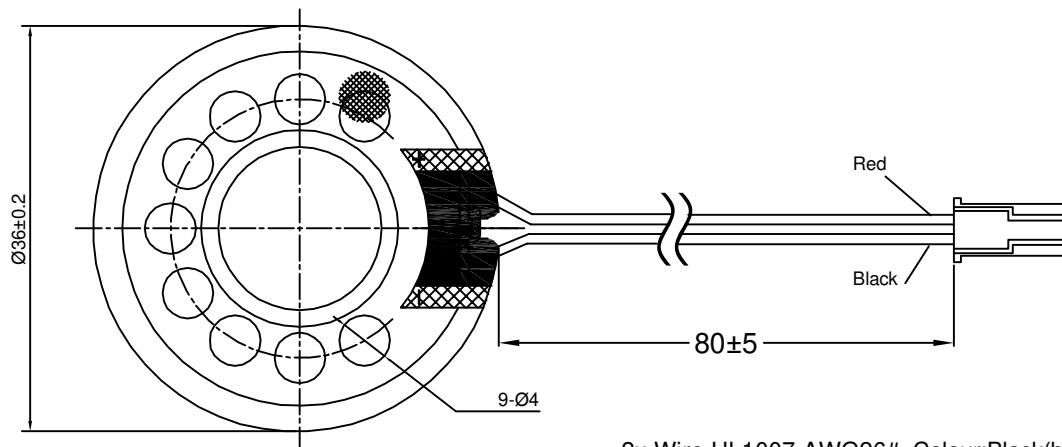

2x Wire UL1007 AWG26# ,Colour:Black(b) and red(r)  
Connector:JST PAP-02V-S,Terminal: JST PN SPHD-001T-P0.5

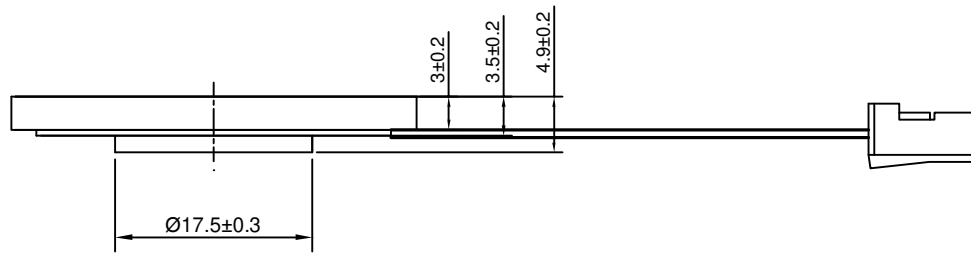

This print and information there in are proprietary to Be Star Acoustics Co., Ltd. and shall not be used in whole or in part without its written content

				Date:	2013.07.31	BMS36-11-50H5.0W80JST LF	
B	2013.07.31	胡兆俊		Drawn by:	胡兆俊		
A	2012.07.04	莫丽丽		Checked by:	莫丽丽	Speaker	
Rev.	Date	Drawn	Note	Approved by:	王平		
BESTAR ACOUSTICS CO.,LTD www.bestargroups.com wu@be-star.com						DRG NO: BS/TES01.1130B	Page:05 of 08

# BMS36-11-50H5.0W80JST LF

## 3. Reliability Test

### 3.1 Load Test

Input Power                      0.5W  
Duration                              96hrs

### 3.2 Heat Test

Temperature                      +85°C±2°C  
Duration                              96hrs

### 3.3 Cold Test

Temperature                      -40°C±2°C  
Duration                              96hrs

### 3.4 Moisture Test

Temperature                      +40°C±2°C  
Humidity                              90%-95%RH  
Duration                              96hrs

### 3.5 Temperature shock

Low temperature                      -40°C  
Upper temperature                      +85°C  
Dwell time each temperature              30min.  
Transfer time from lower to upper temperature < 10s  
Number of cycles                      100

### 3.6 Vibration Test

Vibration Frequency                      10~55Hz  
Amplitude                              1.52mm  
Duration                              2hrs each of 3 axis

### 3.7 Drop test

Height of drop                              1.2m  
Ground                                      concrete floor  
Temperature                              room conditions  
Number of drops                              20

After each test, all acoustic and electrical characteristic should be satisfied with specification.

This print and information there in are proprietary to Be Star Acoustics Co., Ltd. and shall not be used in whole or in part without its written content

				Date:	2013.07.31	BMS36-11-50H5.0W80JST LF	
B	2013.07.31	胡兆俊		Drawn by:	胡兆俊		
A	2012.07.04	莫丽丽		Checked by:	莫丽丽	Speaker	
Rev.	Date	Drawn	Note	Approved by:	王 平		
BESTAR ACOUSTICS CO.,LTD						DRG NO: BS/TES01.1130B	Page:06 of 08
www.bestargroups.com wu@be-star.com							

# BMS36-11-50H5.0W80JST LF

## 4. Packing

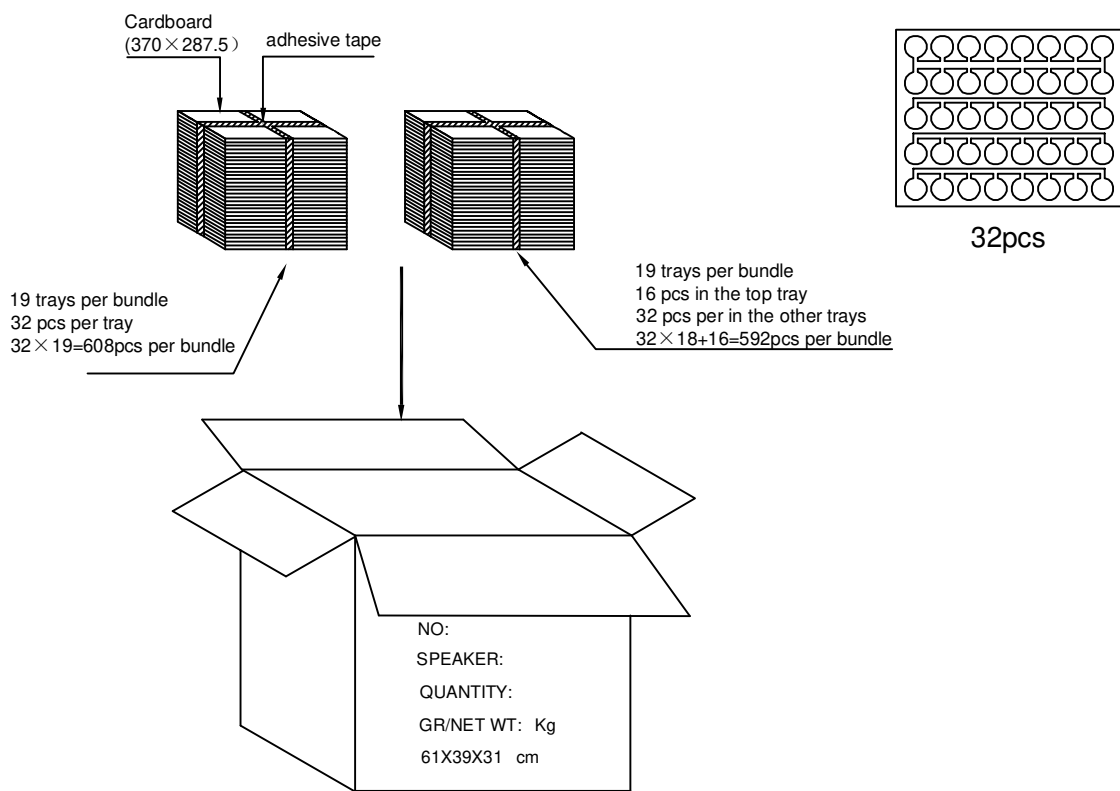

Remark:  
32 pcs per tray  
19 pcs trays per bundle  
2 bundles per carton  
608+592=1200 pcs per carton  
Size: 61X39X31(cm)

This print and information there in are proprietary to Be Star Acoustics Co., Ltd. and shall not be used in whole or in part without its written content

				Date:	2013.07.31	BMS36-11-50H5.0W80JST LF	
B	2013.07.31	胡兆俊		Drawn by:	胡兆俊		
A	2012.07.04	莫丽丽		Checked by:	莫丽丽	Speaker	
Rev.	Date	Drawn	Note	Approved by:	王平		
BESTAR ACOUSTICS CO.,LTD						DRG NO: BS/TES01.1130B	Page:07 of 08
www.bestargroups.com wu@be-star.com							



# BMS36-11-50H5.0W80JST LF

## 5. History change record

version No.	Change Items		Date	Drawn	Approved
	Before	After			
A			2012.07.04	莫丽丽	张秀琴
B	1152 pcs per carton	1200 pcs per carton	2013.07.31	胡兆俊	王 平

This print and information there in are proprietary to Be Star Acoustics Co., Ltd. and shall not be used in whole or in part without its written content.

				Date:	2013.07.31	BMS36-11-50H5.0W80JST LF
B	2013.07.31	胡兆俊		Drawn by:	胡兆俊	
A	2012.07.04	莫丽丽		Checked by:	莫丽丽	
Rev.	Date	Drawn	Note	Approved by:	王 平	Speaker
BESTAR ACOUSTICS CO.,LTD						
www.bestargroups.com wu@be-star.com						DRG NO: BS/TES01.1130B
						Page:08 of 08