



MCF5249

ColdFire[®] Integrated Microprocessor User's Manual

MCF5249UM/D
Rev. 4.0, 10/2003

Document Revision History

Document Revision History

Rev. No.	Date	Substantive Change(s)
1.0	10/2002	Chapter 21, Electrical Specifications
2.0	05/2003	Chapter 21, Electrical Specifications
3.0	08/2003	Chapter 4, QSPISEL bit
4.0	10/29/03	Chapter 21, Electrical Specifications

TABLE OF CONTENTS

Paragraph Number Page Number

SECTION 1 INTRODUCTION 1

1.1	MCF5249 Overview	1-1
1.2	MCF5249 Feature Introduction	1-1
1.3	MCF5249 Block Diagram	1-2
1.4	MCF5249 Feature Details	1-3
1.5	160 MAPBGA Ball Assignments	1-5
1.6	MCF5249 Functional Overview	1-6
1.6.1	ColdFire V2 Core	1-6
1.6.2	DMA Controller	1-6
1.6.3	Enhanced Multiply and Accumulate Module (EMAC)	1-6
1.6.4	Instruction Cache	1-6
1.6.5	Internal 96-KByte SRAM	1-6
1.6.6	DRAM Controller	1-7
1.6.7	System Interface	1-7
1.6.8	External Bus Interface	1-7
1.6.9	Serial Audio Interfaces	1-7
1.6.10	IEC958 Digital Audio Interfaces	1-7
1.6.11	Audio Bus	1-7
1.6.12	CD-ROM Encoder/Decoder	1-8
1.6.13	Dual UART Module	1-8
1.6.14	Queued Serial Peripheral Interface QSPI	1-8
1.6.15	Timer Module	1-8
1.6.16	IDE and SmartMedia Interfaces	1-9
1.6.17	Analog/Digital Converter (ADC)	1-9
1.6.18	Flash Memory Card Interface	1-9
1.6.19	I ² C Module	1-9
1.6.20	Chip-Selects	1-9
1.6.21	GPIO Interface	1-9
1.6.22	Interrupt Controller	1-9
1.6.23	JTAG	1-10
1.6.24	System Debug Interface	1-10
1.6.25	Crystal and On-chip PLL	1-10

SECTION 2 SIGNAL DESCRIPTION

2.1	Introduction	2-1
2.2	GPIO	2-4
2.3	MCF5249 BUS SIGNALS	2-4
2.3.1	ADDRESS BUS	2-4
2.3.2	READ-WRITE CONTROL	2-4
2.3.3	OUTPUT ENABLE	2-5
2.3.4	Data Bus	2-5
2.3.5	Transfer Acknowledge	2-5
2.4	SDRAM Controller Signals	2-5
2.5	CHIP SELECTS	2-5
2.6	ISA bus	2-6
2.7	bus buffer signals	2-6

Paragraph Number		Page Number
2.8	I2C Module Signals	2-6
2.9	Serial Module Signals	2-6
2.10	Timer Module Signals	2-7
2.11	Serial Audio Interface Signals	2-7
2.12	Digital Audio Interface Signals	2-9
2.13	Subcode interface	2-9
2.14	Analog to Digital Converter (ADC)	2-9
2.15	Secure Digital/ MemoryStick card Interface	2-10
2.16	Queued Serial Peripheral Interface (QSPI)	2-10
2.17	Crystal Trim	2-11
2.18	Clock Out	2-11
2.19	Debug and Test Signals	2-11
2.19.1	Test Mode	2-11
2.19.2	High Impedance	2-11
2.19.3	Processor Clock Output	2-11
2.19.4	Debug Data	2-11
2.19.5	Processor Status	2-11
2.20	BDM/JTAG Signals	2-12
2.20.1	Test Clock	2-12
2.20.2	Test Reset/Development Serial Clock	2-12
2.20.3	Test Mode Select/Break Point	2-13
2.20.4	Test Data Input/Development Serial Input	2-13
2.20.5	Test Data Output/Development Serial Output	2-13
2.21	Clock and Reset signals	2-14
2.21.1	Reset In	2-14
2.21.2	System Bus input	2-14

SECTION 3 COLD FIRE CORE

3.1	Processor Pipelines	3-1
3.2	Processor Register Description	3-2
3.2.1	User Programming Model	3-2
3.2.1.1	Data Registers (D0–D7)	3-2
3.2.1.2	Address Registers (A0–A6)	3-2
3.2.1.3	Stack Pointer (A7, SP)	3-2
3.2.1.4	Program Counter (PC)	3-3
3.2.1.5	Condition Code Register (CCR)	3-3
3.2.2	Enhanced Multiply Accumulate Module (EMAC) User Programming Model	3-4
3.2.2.1	EMAC Instruction Set Summary	3-4
3.2.3	Supervisor Programming Model	3-5
3.2.3.1	Status Register (SR)	3-6
3.2.3.2	Vector Base Register (VBR)	3-6
3.3	Exception Processing Overview	3-7
3.4	Exception Stack Frame Definition	3-8
3.5	Processor Exceptions	3-10
3.5.1	Access Error Exception	3-10
3.5.2	Address Error Exception	3-10
3.5.3	Illegal Instruction Exception	3-10
3.5.4	Divide By Zero	3-10
3.5.5	Privilege Violation	3-11
3.5.6	Trace Exception	3-11

Paragraph Number		Page Number
3.5.7	Debug Interrupt	3-11
3.5.8	RTE and Format Error Exceptions	3-11
3.5.9	TRAP Instruction Exceptions	3-12
3.5.10	Interrupt Exception	3-12
3.5.11	Fault-on-Fault Halt	3-12
3.5.12	Reset Exception	3-12
3.6	Instruction Execution Timing	3-12
3.6.1	Timing Assumptions	3-13
3.6.2	MOVE Instruction Execution Times	3-13
3.7	Standard One Operand Instruction Execution Times	3-15
3.8	Standard Two Operand Instruction Execution Times	3-16
3.9	Miscellaneous Instruction Execution Times	3-18
3.10	Branch Instruction Execution Times	3-19

**SECTION 4
PHASE-LOCKED LOOP AND CLOCK DIVIDERS**

4.1	PLL Features	4-1
4.2	PLL Programming	4-2
4.2.1	PLL Operation	4-4
4.2.2	PLL Lock-in Time	4-4
4.2.3	PLL Electrical Limits	4-4
4.3	Audio Clock Generation	4-5
4.4	Reduced Power Mode	4-6
4.5	Recommended Settings	4-6

**SECTION 5
INSTRUCTION CACHE**

5.1	Instruction Cache Features	5-1
5.2	Instruction Cache Physical Organization	5-1
5.3	Instruction Cache Operation	5-2
5.3.1	Interaction with Other Modules	5-2
5.3.2	Memory Reference Attributes	5-3
5.3.3	Cache Coherency and Invalidation	5-3
5.3.4	Reset	5-3
5.3.5	Cache Miss Fetch Algorithm/Line Fills	5-3
5.4	Instruction Cache Programming Model	5-5
5.4.1	Instruction Cache Registers Memory Map	5-5
5.4.2	Instruction Cache Register	5-6
5.4.2.1	Cache Control Register	5-6
5.4.2.2	Access Control Registers	5-8

SECTION 6 STATIC RAM (SRAM)

6.1	SRAM Features	6-1
6.2	SRAM Operation	6-1
6.3	SRAM Programming Model	6-1
6.3.1	SRAM Base Address Register	6-1
6.3.2	SRAM Initialization	6-4
6.3.3	SRAM Initialization Code	6-4
6.3.4	Power Management	6-4

SECTION 7 SYNCHRONOUS DRAM CONTROLLER MODULE

7.1	DRAM Features	7-1
7.1.1	Definitions	7-1
7.1.2	Block Diagram and Major Components	7-1
7.2	DRAM Controller Operation	7-2
7.2.1	DRAM Controller Registers	7-2
7.3	Synchronous Operation	7-3
7.3.1	DRAM Controller Signals in Synchronous Mode	7-4
7.3.2	Synchronous Register Set	7-5
7.3.2.1	DRAM Control Register (DCR) (Synchronous Mode)	7-5
7.3.2.2	DRAM Address and Control (DACR0/DACR1) (Synchronous Mode)	7-7
7.3.2.3	DRAM Controller Mask Registers (DMR0/DMR1)	7-9
7.3.3	General Synchronous Operation Guidelines	7-10
7.3.3.1	Address Multiplexing	7-10
7.3.3.2	Interfacing Example	7-11
7.3.3.3	Burst Page Mode	7-11
7.3.3.4	Continuous Page Mode	7-13
7.3.3.5	Auto-Refresh Operation	7-15
7.3.3.6	Self-Refresh Operation	7-16
7.3.4	Initialization Sequence	7-17
7.3.4.1	Mode Register Settings	7-17
7.4	SDRAM Example	7-18
7.4.1	SDRAM Interface Configuration	7-18
7.4.2	DCR Initialization	7-19
7.4.3	DACR Initialization	7-19
7.4.4	DMR Initialization	7-21
7.4.5	Mode Register Initialization	7-22
7.4.6	Initialization Code	7-23

SECTION 8 BUS OPERATION

8.1	Bus Features	8-1
8.2	Bus And Control Signals	8-1
8.2.1	Address Bus	8-1
8.2.2	Read/Write control	8-2
8.2.3	Transfer Acknowledge (TA)	8-2
8.2.4	Data Bus	8-2
8.2.5	Chip Selects	8-3
8.2.6	Output Enable	8-3

Paragraph Number		Page Number
8.3	Clock and Reset Signals	8-3
8.3.1	Reset In	8-4
8.3.2	System Bus Clock Output	8-4
8.4	Bus Characteristics	8-4
8.5	Data Transfer Operation	8-5
8.5.1	Bus Cycle Execution	8-6
8.5.2	Read Cycle	8-7
8.5.3	Write Cycle	8-8
8.5.4	Back-to-Back Bus Cycles	8-10
8.5.5	Burst Cycles	8-11
8.5.5.1	Line Transfers	8-11
8.5.5.2	Line Read Bus Cycles	8-11
8.5.5.3	Line Write Bus Cycles	8-12
8.6	Misaligned Operands	8-14
8.7	Reset Operation	8-15
8.7.1	Software Watchdog Reset	8-16

**SECTION 9
SYSTEM INTEGRATION MODULE**

9.1	SIM Introduction	9-1
9.1.1	SIM Features	9-1
9.2	Programming Model	9-1
9.2.1	SIM Register Memory Map	9-1
9.3	SIM Programming and Configuration	9-3
9.3.1	Module Base Address Registers	9-3
9.3.2	Device ID	9-5
9.3.3	Interrupt Controller	9-6
9.4	Interrupt Interface	9-6
9.4.1	Primary controller Interrupt Registers	9-6
9.4.1.1	Interrupt Mask Register	9-9
9.4.1.2	Interrupt Pending Register	9-10
9.4.2	Secondary Interrupt Controller Registers	9-11
9.4.2.1	Interrupt Level Selection	9-11
9.4.2.2	Interrupt Vector Generation	9-12
9.4.2.3	Spurious Vector Register	9-12
9.4.2.4	Secondary Interrupt Sources	9-12
9.4.3	Software interrupts	9-15
9.5	System Protection And Reset Status	9-15
9.5.1	Reset Status Register	9-15
9.5.2	Software Watchdog Timer	9-16
9.5.2.1	System Protection Control Register	9-18
9.5.2.2	Software Watchdog Interrupt Vector Register	9-19
9.5.2.3	Software Watchdog Service Register	9-20
9.6	CPU STOP Instruction	9-20
9.7	MCF5249 Bus Arbitration Control	9-20
9.7.1	Default Bus Master Park Register	9-20
9.7.1.1	Internal Arbitration Operation	9-20
9.7.1.2	PARK Register Bit Configuration	9-21
9.8	General Purpose I/Os	9-23
9.8.1	General Purpose Inputs	9-23
9.8.1.1	General Purpose Input Interrupts	9-25
9.8.2	General Purpose Outputs	9-26

SECTION 10 CHIP-SELECT MODULE

10.1	Introduction	10-1
10.1.1	Chip Select Features	10-1
10.2	Chip-Select Signals	10-1
10.2.1	Chip Selects	10-1
10.2.1.1	CS0	10-1
10.2.1.2	CS1/GPIO1	10-1
10.2.1.3	CS2/IDE-DIOR/GPIO13 and IDE-DIOW/GPIO14	10-1
10.2.1.4	CS3/SRE/GPIO11 and SWE/GPIO12	10-2
10.2.2	Output Enable OE/gpio9	10-2
10.2.3	buffer enable signals - bufenb1 and bufenb2	10-2
10.2.4	IORDY - bus termination signal	10-2
10.3	MCF5249Chip-Select Operation	10-2
10.3.1	Chip-Select Module	10-2
10.3.1.1	General Chip Select Operation	10-3
10.3.1.1.1	Port Sizing	10-4
10.3.2	Global Chip-Select Operation	10-4
10.4	Programming Model	10-4
10.4.1	Chip-Select Registers Memory Map	10-4
10.4.2	Chip Select Module Registers	10-6
10.4.2.1	Chip Select Address Register	10-6
10.4.2.2	Chip Select Mask Register	10-6
10.4.2.3	Chip Select Control Register	10-8
10.4.2.4	Code example	10-10

SECTION 11 TIMER MODULE

11.1	Timer Module Overview	11-1
11.2	Timer Features	11-1
11.3	Timer Signals	11-1
11.3.1	Timer Inputs	11-1
11.3.2	Timer Outputs	11-1
11.4	General-Purpose Timer Units	11-2
11.4.1	Selecting the Prescaler	11-3
11.4.2	Capture Mode	11-3
11.4.3	Configuring the Timer for Reference Compare	11-3
11.4.4	Configuring the Timer for Output Mode	11-3
11.5	General-Purpose Timer Registers	11-3
11.5.1	Timer Mode Registers (TMR0, TMR1)	11-4
11.5.2	Timer Reference Registers (TRR0, TRR1)	11-5
11.5.3	Timer Capture Registers (TCR0, TCR1)	11-5
11.5.4	Timer Counters (TCN0, TCN1)	11-6
11.5.5	Timer Event Registers (TER0, TER1)	11-6
11.5.6	Timer Initialization Example Code	11-7
11.5.6.1	Timer 0 (Timer Mode Register)	11-7
11.5.6.2	Timer 0 (Timer Reference Register 0)	11-8
11.5.6.3	Timer 1 (Timer Mode Register 1)	11-8

Paragraph Number		Page Number
---------------------	--	----------------

**SECTION 12
ANALOG TO DIGITAL CONVERTER (ADC)**

12.1	ADC Overview	12-1
12.2	ADC Functionality	12-2

**SECTION 13
IDE AND FLASHMEDIA INTERFACE**

13.1	IDE and SmartMedia Overview	13-1
13.1.1	Buffer enables bufenb1, bufenB2, and associated logic.	13-2
13.1.2	Generation of IDE-DIOR, IDE-DIOW, SRE, SWE	13-4
13.1.3	Cycle termination on CS2, CS3 (DIOR, DIOW, SRE, SWE)	13-5
13.2	SmartMedia Interface Setup	13-6
13.2.1	SmartMedia timing	13-7
13.3	Setting Up The IDE Interface	13-8
13.3.1	IDE timing diagram	13-8
13.4	FlashMedia Interface	13-10
13.4.1	FlashMedia Interface Registers	13-10
13.4.1.1	FlashMedia Clock Generation and Configuration	13-11
13.4.2	FlashMedia Interface Operation	13-12
13.4.2.1	FlashMedia Command Registers in MemoryStick Mode	13-13
13.4.2.2	FlashMedia Command Register 1 in Secure Digital Mode	13-13
13.4.2.3	FLASHMEDIA COMMAND REGISTER 2 in Secure Digital Mode	13-14
13.4.3	FlashMedia Data Register	13-15
13.4.3.1	FlashMedia Status Register	13-15
13.4.4	FlashMedia Interrupt Interface	13-15
13.4.5	FlashMedia Interface Operation in MemoryStick Mode	13-16
13.4.5.1	Reading Data From the MemoryStick	13-17
13.4.5.2	Writing Data to the MemoryStick	13-18
13.4.5.3	Interrupt From MemoryStick	13-19
13.4.6	FlashMedia interface Operation in Secure Digital (SD) mode	13-20
13.4.6.1	Sent Command To Card	13-20
13.4.6.2	Write Data To Card	13-21
13.4.7	Commonly used commands in SD mode	13-23
13.4.7.1	Send Command To Card (No Data)	13-23
13.4.7.2	Send Command To Card (Receive Multiple Data Blocks and Status)	13-24
13.4.7.3	Send Command To Card (Write Multiple Data Blocks)	13-25

**SECTION 14
DMA CONTROLLER MODULE**

14.1	DMA Features	14-2
14.2	DMA Signal Description	14-2
14.2.1	DMA Request	14-2
14.3	DMA Module Overview	14-2
14.4	DMA Programming Model	14-3
14.4.1	REQUEST source selection	14-5
14.4.2	Source Address Register	14-8
14.4.3	FLASHmEDIA DATA RegisterS	14-9
14.4.4	Byte Count Register	14-9
14.4.5	DMA Control Register	14-10

Paragraph Number		Page Number
14.4.6	DMA Status Register	14-13
14.4.7	DMA Interrupt Vector Register	14-15
14.5	Transfer Request Generation	14-15
14.5.1	Cycle-Steal Mode	14-15
14.5.2	Continuous Mode	14-15
14.6	Data Transfer Modes	14-16
14.6.1	Dual-Address Transaction	14-16
14.6.1.1	Dual-Address Read	14-16
14.6.1.2	Dual-Address Write	14-16
14.7	DMA Transfer Functional Description	14-16
14.7.1	Channel Initialization and Startup	14-17
14.7.1.1	Channel Prioritization	14-17
14.7.1.2	Programming the DMA	14-17
14.7.2	Data Transfer	14-18
14.7.2.1	Periphery Request Operation	14-18
14.7.2.2	Auto Alignment	14-18
14.7.2.3	Bandwidth Control	14-19
14.7.3	Channel Termination	14-19
14.7.3.1	Error Conditions	14-19
14.7.3.2	Interrupts	14-19

SECTION 15 UART MODULES

15.1	Module Overview	15-1
15.1.1	Serial Communication Channel	15-2
15.1.2	Baud-Rate Generator/Timer	15-2
15.1.3	Interrupt Control Logic	15-2
15.2	UART Module Signal Definitions	15-3
15.2.1	Transmitter Serial Data Output	15-3
15.2.2	Receiver Serial Data Input	15-3
15.2.3	Request-To-Send	15-4
15.2.4	Clear-To-Send	15-4
15.3	Operation	15-4
15.3.1	Baud-Rate Generator/Timer	15-4
15.3.2	Transmitter and Receiver Operating Modes	15-5
15.3.2.1	Transmitter	15-5
15.3.2.2	Receiver	15-7
15.3.2.3	Receiver FIFO	15-8
15.3.3	Looping Modes	15-9
15.3.3.1	Automatic Echo Mode	15-9
15.3.3.2	Local Loopback Mode	15-9
15.3.3.3	Remote Loopback Mode	15-10
15.3.4	Multidrop Mode	15-10
15.3.5	Bus Operation	15-12
15.3.5.1	Read Cycles	15-12
15.3.5.2	Write Cycles	15-12
15.3.5.3	Interrupt Acknowledge Cycles	15-12
15.4	Register Description and Programming	15-12
15.4.1	Register Description	15-12
15.4.1.1	Mode Register 1 (UMR1n)	15-13
15.4.1.2	Mode Register 2 (UMR2n)	15-15

Paragraph Number		Page Number
15.4.1.3	Status Registers (USRn)	15-18
15.4.1.4	Clock-Select Registers (USCRn)	15-19
15.4.1.5	Command Registers (UCRn)	15-20
15.4.1.6	Miscellaneous Commands	15-20
15.4.1.6.1	Reset Mode Register Pointer	15-21
15.4.1.6.2	Reset Receiver	15-21
15.4.1.6.3	Reset Transmitter	15-21
15.4.1.6.4	Reset Error Status	15-21
15.4.1.6.5	Reset Break-Change Interrupt	15-21
15.4.1.6.6	Start Break	15-21
15.4.1.6.7	Stop Break	15-21
15.4.1.7	Transmitter Commands	15-21
15.4.1.7.1	No Action Taken	15-22
15.4.1.7.2	Transmitter Enable	15-22
15.4.1.7.3	Transmitter Disable	15-22
15.4.1.7.4	Do Not Use	15-22
15.4.1.8	Receiver Commands	15-22
15.4.1.8.1	No Action Taken	15-22
15.4.1.8.2	Receiver Enable	15-22
15.4.1.8.3	Receiver Disable	15-23
15.4.1.8.4	Do Not Use	15-23
15.4.1.9	Receiver Buffer Registers (UBRn)	15-23
15.4.1.10	Transmitter Buffer Registers (UTBn)	15-23
15.4.1.11	Input Port Change Registers UIPCRn)	15-24
15.4.1.12	Auxiliary Control Registers (UACRn)	15-24
15.4.1.13	Interrupt Status Registers (UISRn)	15-25
15.4.1.14	Interrupt Mask Registers UIMRn)	15-26
15.4.1.15	Timer Upper Preload Register (UBG1n)	15-27
15.4.1.16	Timer Upper Preload Register 2 (UBG2n)	15-27
15.4.1.17	Interrupt Vector Registers (UIVRn)	15-27
15.4.1.18	Input Port Registers (UIPn)	15-28
15.4.1.19	Output Port Data Registers (UOP1n)	15-28
15.4.2	Programming	15-29
15.4.2.1	UART Module Initialization	15-29
15.4.2.2	I/O Driver Example	15-29
15.4.1.3	Interrupt Handling	15-29
15.5	UART Module Initialization Sequence	15-30

**SECTION 16
QUEUED SERIAL PERIPHERAL INTERFACE (QSPI) MODULE**

16.1	Overview	16-1
16.2	Features	16-1
16.3	Module Description	16-1
16.3.1	Interface and Pins	16-1
16.3.2	Internal Bus Interface	16-2
16.4	Operation	16-3
16.4.1	QSPI RAM	16-3
16.4.1.1	Transmit RAM	16-5
16.4.1.2	Receive RAM	16-5
16.4.1.3	Command RAM	16-5
16.4.2	Baud Rate Selection	16-6

Paragraph Number		Page Number
16.4.3	Transfer Delays	16-6
16.4.4	Transfer Length	16-7
16.4.5	Data Transfer	16-7
16.5	Programming Model	16-8
16.5.1	QSPI Mode Register (QMR)	16-8
16.5.2	QSPI Delay Register (QDLYR)	16-10
16.5.3	QSPI Wrap Register (QWR)	16-10
16.5.4	QSPI Interrupt Register (QIR)	16-11
16.5.5	QSPI Address Register (QAR)	16-12
16.5.6	QSPI Data Register (QDR)	16-13
16.5.7	Command RAM Registers (QCR0–QCR15)	16-13
16.5.8	Programming Example	16-15

SECTION 17 AUDIO FUNCTIONS

17.1	Audio Interface Overview	17-1
17.1.1	Audio Interface Structure	17-2
17.1.1.1	Audio Interrupt Mask and Interrupt Status Registers	17-3
17.2	Serial Audio Interface (IIS/EIAJ)	17-5
17.2.1	IIS/EIAJ Transmitter Descriptions	17-9
17.2.2	IIS/EIAJ Transmitter Interrupts	17-9
17.2.3	IIS/EIAJ Receiver Descriptions	17-9
17.3	Digital Audio Interface (EBU)	17-10
17.3.1	IEC958 Receive Interface	17-13
17.3.1.1	Audio Data Reception	17-13
17.3.1.2	Control Channel Reception	17-13
17.3.1.3	Control Channel Interrupt (IEC958 “C” Channel New Frame)	17-13
17.3.1.4	Validity Flag Reception	17-13
17.3.1.5	IEC958 Exception Definition	17-14
17.3.1.6	EBU Extracted Clock	17-14
17.3.1.7	Reception of User Channel and CD-subcode Over IEC958 Receiver	17-14
17.3.1.8	U and Q Receive Register Interrupts	17-16
17.3.1.9	Behavior of User Channel Receive Interface (CD Data)	17-16
17.3.1.10	Behavior of User Channel Receive Interface (non-CD data)	17-18
17.3.2	IEC958 Transmit Interface	17-18
17.3.2.1	Transmit “C” Channel	17-18
17.3.2.2	IEC958 Transmitter Exception Conditions	17-19
17.3.2.3	IEC958-3 Ed2 and Tech 3250-E Standards Compliance	17-19
17.3.2.4	Transmission of U-Channel and CD Subcode Data	17-20
17.3.3	CD Subcode Interrupts	17-21
17.3.3.1	Free Running Counter Synchronization	17-22
17.3.3.2	Controlling the SFSY Sync Position	17-22
17.3.4	Inserting CD User Channel Data Into IEC958 Transmit Data	17-22
17.4	Processor Interface Overview	17-23
17.4.1	Data Exchange Register Descriptions	17-23
17.4.2	Data Exchange Register Overview	17-24
17.4.2.1	Data In Selection	17-25
17.4.3	PDIR and PDOR Field Formatting	17-27
17.4.4	Overrun and Underrun with PDIR and PDOR Registers	17-27
17.4.5	Automatic Resynchronization of FIFOs	17-28
17.4.6	Audio Interrupts	17-30

Paragraph Number		Page Number
17.4.6.1	AudioTick Interrupts	17-30
17.4.6.2	PDIR1, PDIR2, and PDIR3, Exceptions	17-30
17.4.6.3	PDOR1, PDOR2, and PDOR3 Exceptions	17-30
17.4.6.4	Audio Interrupt Routines and Timing	17-32
17.4.7	CD-ROM Block Encoder and Decoder	17-33
17.4.7.1	CD-ROM Decoder Interrupts	17-35
17.4.7.2	CD-ROM Encoder Interrupts	17-36
17.5	DMA Channel Interaction	17-36
17.6	Phase/Frequency Determination and Xtrim Function	17-37
17.6.1	Incoming Source Frequency Measurement	17-37
17.6.1.1	Filtering for the Discrete Time Oscillator	17-40
17.6.2	XTRIM Option - Locking Xtal Clock to Incoming Signal	17-40
17.6.3	XTRIM Internal Logic	17-40
17.7	Audio Interface Memory Map	17-41

SECTION 18 I²C MODULES

18.1	I ² C Overview	18-1
18.2	I ² C Interface Features	18-1
18.3	I ² C System Configuration	18-2
18.4	I ² C Protocol	18-3
18.4.1	START Signal	18-3
18.4.2	Slave Address Transmission	18-3
18.4.3	Data Transfer	18-4
18.4.4	Repeated START Signal	18-4
18.4.5	STOP Signal	18-4
18.4.6	Arbitration Procedure	18-4
18.4.7	Clock Synchronization	18-4
18.4.8	Handshaking	18-5
18.4.9	Clock Stretching	18-5
18.5	Programming Model	18-5
18.5.1	I ² C Address Registers (MADR)	18-6
18.5.2	I ² C Frequency Divider Registers (MFDR)	18-6
18.5.3	I ² C Control Registers (MBCR)	18-8
18.5.4	I ² C Status Registers (MBSR)	18-10
18.5.5	I ² C Data I/O Registers (MBDR)	18-11
18.6	I ² C Programming Examples	18-12
18.6.1	Initialization Sequence	18-12
18.6.2	Generation of START	18-12
18.6.3	Post-Transfer Software Response	18-13
18.6.4	Slave Mode	18-14
18.6.5	Arbitration Lost	18-15

SECTION 19 DEBUG SUPPORT

19.1	Breakpoint (BKPT)	19-1
19.1.1	Debug Support Signals	19-1
19.1.2	Debug Data (DDATA[3:0])	19-1
19.1.3	Development Serial Clock (DSCLK)	19-2
19.1.4	Development Serial Input (DSI)	19-2

Paragraph Number		Page Number
19.1.5	Development Serial Output (DSO)	19-2
19.1.6	Processor Status (PST[3:0])	19-2
19.1.7	Processor Status Clock (PSTCLK)	19-3
19.2	Real-Time Trace Support	19-4
19.2.1	Processor Status Signal Encoding	19-4
19.2.1.1	Continue Execution (PST = \$0)	19-4
19.2.1.2	Begin Execution of an Instruction (PST = \$1)	19-4
19.2.1.3	Entry into User Mode (PST = \$3)	19-4
19.2.1.4	Begin Execution of PULSE or WDDATA instructions (PST = \$4)	19-4
19.2.1.5	Begin Execution of Taken Branch (PST = \$5)	19-5
19.2.1.6	Begin Execution of RTE Instruction (PST = \$7)	19-6
19.2.1.7	Begin Data Transfer (PST = \$8-\$B)	19-6
19.2.1.8	Exception Processing (PST = \$C)	19-6
19.2.1.9	Emulator Mode Exception Processing (PST = \$D)	19-6
19.2.1.10	Processor Stopped (PST = \$E)	19-6
19.2.1.11	Processor Halted (PST = \$F)	19-6
19.3	Background-Debug Mode (BDM)	19-6
19.3.1	CPU Halt	19-7
19.3.2	BDM Serial Interface	19-7
19.3.2.1	Receive Packet Format	19-8
19.3.2.2	Transmit Packet Format	19-9
19.3.3	BDM Command Set	19-9
19.3.3.1	BDM Command Set Summary	19-9
19.3.3.2	ColdFire BDM Commands	19-9
19.3.3.3	Command Sequence Diagram	19-11
19.3.3.4	Command Set Descriptions	19-13
19.3.3.4.1	Read Address/Data Register (RAREG/RDREG)	19-13
19.3.3.4.2	Write Address/Data Register (WAREG and WDREG)	19-13
19.3.3.4.3	Read Memory Location (READ)	19-14
19.3.3.4.4	Write Memory Location (WRITE)	19-16
19.3.3.4.5	Dump Memory Block (DUMP)	19-17
19.3.3.4.6	Fill Memory Block (FILL)	19-18
19.3.3.4.7	Resume Execution (GO)	19-20
19.3.3.4.8	No Operation (NOP)	19-20
19.3.3.4.9	Read Control Register (RCREG)	19-21
19.3.3.4.10	Write Control Register (WCREG)	19-22
19.3.3.4.11	Read Debug Module Register (RDMREG)	19-22
19.3.3.4.12	Write Debug Module Register (WDMREG)	19-23
19.3.3.4.13	Unassigned Opcodes	19-24
19.3.3.5	BDM Accesses of the EMAC Registers	19-24
19.4	Real-Time Debug Support	19-25
19.4.1	Theory of Operation	19-26
19.4.1.1	Emulator Mode	19-27
19.4.1.2	Debug Module Hardware	19-27
19.4.1.2.1	Reuse of Debug Module Hardware (Rev. A)	19-27
19.4.2	Programming Model	19-28
19.4.2.1	Address Breakpoint Registers	19-28
19.4.2.2	Address Attribute Trigger Register	19-29
19.4.2.3	Program Counter Breakpoint Register (PBR, PBMR)	19-31
19.4.2.4	Data Breakpoint Registers (DBR, DBMR)	19-32
19.4.2.5	Trigger Definition Register (TDR)	19-34
19.4.2.6	Configuration/Status Register (CSR)	19-36

Paragraph Number		Page Number
19.4.2.7	BDM Address Attribute (BAAR)	19-39
19.4.3	Concurrent BDM and Processor Operation	19-40
19.4.4	Motorola-Recommended BDM Pinout	19-41

**SECTION 20
IEEE 1149.1 TEST ACCESS PORT (JTAG)**

20.1	JTAG Overview	20-1
20.2	JTAG Signal Descriptions	20-2
20.2.1	Test Clock - (TCK)	20-3
20.2.2	Test Reset/Development Serial Clock - (TRST/DSCLK)	20-3
20.2.3	Test Mode Select/ Breakpoint (TMS/BKPT)	20-3
20.2.4	Test Data Input/Development Serial Input - (TDI/DSI)	20-4
20.2.5	Test Data Output/Development Serial Output - (TDO/DSO)	20-4
20.3	TAP Controller	20-4
20.4	JTAG Registers	20-6
20.4.1	JTAG Instruction Shift Register	20-6
20.4.1.1	EXTEST Instruction	20-6
20.4.1.2	IDCODE	20-6
20.4.1.3	SAMPLE/PRELOAD Instruction	20-7
20.4.1.4	CLAMP Instruction	20-7
20.4.1.5	HIGHZ Instruction	20-7
20.4.1.6	BYPASS Instruction	20-7
20.4.2	IDcode Register	20-8
20.4.3	JTAG Boundary Scan Register	20-8
20.4.4	JTAG Bypass Register	20-9
20.5	Restrictions	20-9
20.6	Disabling IEEE 1149.1A Standard Operation	20-9
20.7	MCF5249 BSDL File	20-10
20.8	Obtaining the IEEE 1149.1A Standard	20-22

**SECTION 21
ELECTRICAL SPECIFICATIONS**

21.1	Supply Voltage Sequencing and Separation Cautions	21-3
21.2	JTAG Timing Definition IIS Module AC Timing Specifications	21-18

**SECTION 22
MECHANICAL DATA**

22.1	Package	22-1
22.2	Pin Assignment	22-1

**APPENDIX A
REGISTER MEMORY MAP**

Intentionally
Left
Blank

LIST OF FIGURES

	Page Number
Figure 1-1	MCF5249 Block Diagram 1-2
Figure 3-1	V2 ColdFire Processor Core Pipelines 2-1
Figure 3-2	User Programming Model 2-3
Figure 3-3	Supervisor Programming Model 2-5
Figure 3-4	Vector Base Register (VBR) 2-6
Figure 3-5	Exception Stack Frame Form 2-9
Figure 4-1	Phase-Locked Loop Module Block Diagram 4-1
Figure 5-1	Instruction Cache Block Diagram 5-2
Figure 7-1	Synchronous DRAM Controller Block Diagram 7-2
Figure 7-2	MCF5249 SDRAM Interface 7-5
Figure 7-3	DRAM Control Register (DCR) (Synchronous Mode) 7-5
Figure 7-4	DACR0 and DACR1 (Synchronous Mode) 7-7
Figure 7-5	DRAM Controller Mask Registers (DMR0 and DMR1) 7-9
Figure 7-6	Burst Read SDRAM Access 7-12
Figure 7-7	Burst Write SDRAM Access 7-13
Figure 7-8	Synchronous, Continuous Page-Mode Access—Consecutive Reads 7-14
Figure 7-9	Synchronous, Continuous Page-Mode Access—Read after Write 7-15
Figure 7-10	Auto-Refresh Operation 7-16
Figure 7-11	Self-Refresh Operation 7-16
Figure 7-12	Mode Register Set (mrs) Command 7-18
Figure 7-13	Initialization Values for DCR 7-19
Figure 7-14	SDRAM Configuration 7-20
Figure 7-15	DACR Register Configuration 7-20
Figure 7-16	DMR0 Register 7-21
Figure 7-17	Mode Register Mapping to MCF5249 A[31:0] 7-22
Figure 8-1	Connections for External Memory Port Sizes 8-3
Figure 8-2	Signal Relationship to BCLK for Non-DRAM Access 8-5
Figure 8-3	Read Cycle Flowchart 8-7
Figure 8-4	Basic Read Bus Cycle 8-7
Figure 8-5	Write Cycle Flowchart 8-9
Figure 8-6	Basic Write Bus Cycle 8-9
Figure 8-7	Back-to-Back Bus Cycles 8-10
Figure 8-8	Line Read Burst (one wait cycle) 8-12
Figure 8-9	Line Read Burst (no wait cycles) 8-12
Figure 8-10	Line Write Burst (no wait cycles) 8-13
Figure 8-11	Line Read Burst-Inhibited 8-13
Figure 8-12	Line Write Burst with One Wait State 8-14
Figure 8-13	Line Write Burst-Inhibited 8-14
Figure 8-14	Misaligned Longword Transfer 8-15
Figure 8-15	Misaligned Word Transfer 8-15
Figure 8-16	Master Reset Timing 8-16
Figure 8-17	Software Watchdog Reset Timing 8-17
Figure 9-1	MCF5249 Unterminated Access Recovery 9-17
Figure 9-2	General-Purpose Pin Logic for Pin ddata3/gpio34 9-27
Figure 11-1	Timer Block Diagram Module Operation 11-2
Figure 12-1	ADC with On-chip and External Parts 12-2
Figure 13-1	Bus Setup with IDE and SmartMedia Interface 13-1
Figure 13-2	Buffer Enables (BUFENB1 and BUFENB2) 13-2
Figure 13-3	DIOR and SRE Timing Diagram 13-5
Figure 13-4	Non-IORDY Controlled IDE/SmartMedia TA Timing 13-6
Figure 13-5	CS2 (DIOR, DIOW) and CS3 (SRE, SWE) Cycle Timing 13-6

	Page Number
Figure 13-6	SmartMedia Timing 13-7
Figure 13-7	IDE Timing 13-8
Figure 13-8	FlashMedia Block Diagram 13-10
Figure 13-9	One Interface Shift Register 13-12
Figure 13-10	Reading Data From MemoryStick 13-17
Figure 13-11	Reading Data From MemoryStick Timing 13-17
Figure 13-12	Writing Data To MemoryStick 13-18
Figure 13-13	Writing Data to MemoryStick Timing 13-18
Figure 13-14	Interrupt From MemoryStick 13-19
Figure 13-15	Interrupt From MemoryStick 13-19
Figure 13-16	Sent Command To Card 13-20
Figure 13-17	Write Data To Card With Busy 13-21
Figure 13-18	Write Data To Card Without Busy 13-22
Figure 13-19	Read Data From Card 13-23
Figure 14-1	DMA Signal Diagram 14-1
Figure 14-2	Dual Address Transfer 14-3
Figure 15-1	UART Block Diagram 15-1
Figure 15-2	External and Internal Interface Signals 15-3
Figure 15-3	Baud-Rate Timer Generator Diagram 15-4
Figure 15-4	Transmitter and Receiver Functional Diagram 15-5
Figure 15-5	Transmitter Timing Diagram 15-6
Figure 15-6	Receiver Timing Diagram 15-7
Figure 15-7	Looping Modes Functional Diagram 15-10
Figure 15-8	Multidrop Mode Timing Diagram 15-11
Figure 15-9	UART Software Flowchart (1 of 5) 15-31
Figure 15-10	UART Software Flowchart (2 of 5) 15-32
Figure 15-11	UART Software Flowchart (3 of 5) 15-33
Figure 15-12	UART Software Flowchart (4 of 5) 15-34
Figure 15-13	UART Software Flowchart (5 of 5) 15-35
Figure 16-1	QSPI Block Diagram 16-2
Figure 16-2	QSPI RAM Model 16-4
Figure 16-3	QSPI Mode Register (QSPIMR) 16-8
Figure 16-4	QSPI Clocking and Data Transfer Example 16-9
Figure 16-5	QSPI Delay Register (QDLYR) 16-10
Figure 16-6	QSPI Wrap Register (QWR) 16-10
Figure 16-7	QSPI Interrupt Register (QIR) 16-11
Figure 16-8	QSPI Address Register (QAR) 16-13
Figure 16-9	QSPI Data Register (QDR) 16-13
Figure 16-10	Command RAM Registers (QCR0–QCR15) 16-14
Figure 16-11	QSPI Timing 16-15
Figure 17-1	Audio Interface Block Diagram 17-2
Figure 17-2	IIS/EIAJ Timing Diagram (16 SCLK edges per word) 17-9
Figure 17-3	IIS/EIAJ timing diagram (24 or 32 SCLK edges per word) 17-10
Figure 17-4	CD-Subcode Interface 17-20
Figure 17-5	Data Format on CD-Subcode Interface Out 17-21
Figure 17-6	Processor/Audio Module Interface 17-23
Figure 17-7	Automatic Resynchronization FSM of left-right FIFOs 17-28
Figure 17-8	Audio Transmit / Receive FIFOs 17-33
Figure 17-9	Block Decoder 17-35
Figure 17-10	Block Encoder 17-36
Figure 17-11	Frequency Measurement Circuit 17-38

	Page Number
Figure 17-12	XTRIM External Circuit 17-40
Figure 17-13	PDM Modulator Used on Xtrim Output 17-41
Figure 18-1	I2C Module Block Diagram 18-2
Figure 18-2	I2C Standard Communication Protocol 18-3
Figure 18-3	Synchronized Clock SCL 18-5
Figure 18-4	Flow-Chart of Typical I ² C Interrupt Routine 18-16
Figure 19-1	Processor/Debug Module Interface 19-1
Figure 19-2	Example PST/DDATA Diagram 19-5
Figure 19-3	1BDM Serial Transfer 19-8
Figure 19-4	Command Sequence Diagram 19-12
Figure 19-5	Command/Result Formats 19-13
Figure 19-6	Read A/D Register Command Sequence 19-13
Figure 19-7	Write A/D Register Command Sequence 19-14
Figure 19-8	WAREG/WDREG Command Format 19-14
Figure 19-9	READ Command/Result Format 19-15
Figure 19-10	Read Memory Location Command Sequence 19-15
Figure 19-11	Write Memory Location Command Sequence 19-16
Figure 19-12	DUMP Command/Result Format 19-17
Figure 19-13	DUMP Memory Block Command Sequence 19-18
Figure 19-14	Fill Memory Block Command Sequence 19-19
Figure 19-15	Resume Execution 19-20
Figure 19-16	No Operation Command Sequence 19-20
Figure 19-17	RCREG Command/Result Formats 19-21
Figure 19-18	WCREG Command Sequence 19-22
Figure 19-19	Write Control Register Command Sequence 19-22
Figure 19-20	RDMREG Command/Result Formats 19-23
Figure 19-21	Read Debug Module Register Command Sequence 19-23
Figure 19-22	WDMREG BDM Command Format 19-23
Figure 19-23	Write Debug Module Register Command Sequence 19-24
Figure 19-24	Read Control Register Command Sequence 19-25
Figure 19-25	Debug Programming Mode 19-28
Figure 19-26	Recommended BDM Connector 19-41
Figure 20-1	JTAG Test Logic Block Diagram 20-2
Figure 20-2	JTAG TAP Controller State Machine 20-5
Figure 20-3	Disabling JTAG in JTAG Mode 20-9
Figure 20-4	Disabling JTAG in Debug Mode 20-10
Figure 21-1	Supply Voltage Sequencing and Separation Cautions 21-3
Figure 21-2	Example Circuit to Control Supply Sequencing 21-4
Figure 21-3	MCF5249 Power Supply 21-4
Figure 21-4	Clock Timing Definition 21-6
Figure 21-5	Input/Output Timing Definition-I 21-8
Figure 21-6	Input/Output Timing Definition-III 21-9
Figure 21-7	Debug Timing Definition 21-10
Figure 21-8	Timer Module Timing Definition 21-11
Figure 21-9	UART Timing Definition 21-12
Figure 21-10	I2C Timing Definition 21-14
Figure 21-11	I2C and System Clock Timing Relationship 21-15
Figure 21-12	General-Purpose Parallel Port Timing Definition 21-15
Figure 21-13 21-17
Figure 21-14	SCLK Input, SDATA Output Timing 21-18
Figure 21-15	SCLK Output, SDATAO Output Timing Diagram 21-18

List of Figures

	Page Number
Figure 21-16	SCLK Input/Output, SDATAI Input Timing Diagram21-19
Figure 22-1	144 QFP Package (1 of 3)22-12
Figure 22-2	144 QFP Package (2 of 3)22-13
Figure 22-3	144 QFP Package (3 of 3)22-14
Figure 22-4	160 BGA Mechanical Package (1 of 2)22-15
Figure 22-5	160 BGA Mechanical Package (2 of 2)22-16

LIST OF TABLES

	Page Number
Table 1-1	160 MAPBGA Ball Assignments 1-5
Table 2-1	MCF5249 Signal Index 2-1
Table 2-2	SDRAM Controller Signals 2-5
Table 2-3	I2C Module Signals 2-6
Table 2-4	Timer Module Signals 2-7
Table 2-5	Serial Module Signals 2-7
Table 2-6	Serial Audio Interface Signals 2-8
Table 2-7	Digital Audio Interface Signals 2-9
Table 2-8	Subcode Interface Signal 2-9
Table 2-9	Flash Memory Card Signals 2-10
Table 2-10	Queued Serial Peripheral Interface (QSPI) Signals 2-10
Table 2-11	Processor Status Signal Encodings 2-12
Table 3-1	Condition Code Register (Bits 0-4) 3-3
Table 3-2	CCR Functionality 3-4
Table 3-3	EMAC Instruction Summary 3-4
Table 3-4	Status Register 3-6
Table 3-5	Status Bit Descriptions 3-6
Table 3-6	Exception Vector Assignments 3-8
Table 3-7	Format Field Encoding 3-9
Table 3-8	Fault Status Encoding 3-9
Table 3-9	Misaligned Operand References 3-13
Table 3-10	Move Byte and Word Execution times 3-14
Table 3-11	Move Long Execution Times 3-14
Table 3-12	One Operand Instruction Execution Times 3-15
Table 3-13	Two Operand Instruction Execution Times - (MACS) 3-16
Table 3-14	Miscellaneous Instruction Execution Times 3-18
Table 3-15	General Branch Instruction Execution Times 3-19
Table 3-16	BRA, Bcc Instruction Execution Times 3-19
Table 4-1	PLLCR Register 4-2
Table 4-2	PLLCR Bit Descriptions 4-2
Table 4-3	PLL Electrical Limits 4-4
Table 4-4	PLLCR Bit Fields 4-5
Table 4-5	Recommended PLL Settings 4-6
Table 5-1	Initial Fetch Offset vs. CLNF Bits 5-4
Table 5-2	Instruction Cache Operation as Defined by CACR[31,10] 5-5
Table 5-3	Memory Map of I-Cache Registers 5-6
Table 5-4	Cache Control Register (CACR) 5-6
Table 5-5	Cache Control Bit Descriptions 5-7
Table 5-6	External Fetch Size Based on Miss Address and CLNF 5-8
Table 5-7	Access Control Registers (ACRo, ACR1) 5-8
Table 5-8	Access Control Bit Descriptions 5-9
Table 6-1	SRAM Base Address Register (RAMBAR0) 6-2
Table 6-2	SRAM1 Base Address Register (RAMBAR1) 6-2
Table 6-3	Cache Control Bit Descriptions 6-3
Table 6-4	Typical RAMBAR Setting Examples 6-4
Table 7-1	DRAM Controller Registers 7-3
Table 7-2	SDRAM Commands 7-3
Table 7-3	Synchronous DRAM Signal Connections 7-4
Table 7-4	DCR Field Descriptions (Synchronous Mode) 7-6
Table 7-5	DACR0/DACR1 Field Descriptions (Synchronous Mode) 7-7
Table 7-6	DMR0/DMR1 Field Descriptions 7-9

List of Tables

	Page Number
Table 7-7	SDRAM Interface (8-Bit Port,10-Column Address Lines)7-10
Table 7-8	SDRAM Interface (16-Bit Port,11-Column Address Lines)7-10
Table 7-9	SDRAM Interface (16-Bit Port,12-Column Address Lines)7-10
Table 7-10	SDRAM Interface (16-Bit Port, 8-Column Address Lines)7-11
Table 7-11	SDRAM Interface (16-Bit Port, 9-Column Address Lines)7-11
Table 7-12	SDRAM Interface (16-Bit Port, 10-Column Address Lines)7-11
Table 7-13	SDRAM Interface (16-Bit Port, 11-Column Address Lines)7-11
Table 7-14	SDRAM Hardware Connections7-11
Table 7-15	SDRAM Example Specifications7-18
Table 7-16	SDRAM Hardware Connections7-19
Table 7-17	DCR Initialization Values7-19
Table 7-18	DACR Initialization Values7-20
Table 7-19	DMR0 Initialization Values7-21
Table 7-20	Mode Register Initialization7-22
Table 8-1	MCF5249 Bus Signal Summary8-1
Table 8-2	Reset Port Settings8-2
Table 8-3	CF-Bus Signal Summary8-4
Table 8-4	Accesses by Matches8-6
Table 8-5	Read Cycle States8-8
Table 8-6	Write Cycle States8-9
Table 8-7	Allowable Line Access Patterns8-11
Table 8-8	Power-on Reset Configuration for CS08-16
Table 9-1	MBAR Register Addresses9-2
Table 9-2	SIM Memory Map9-2
Table 9-3	Module Base Address Register (MBAR)9-4
Table 9-4	Module Base Address Bit Descriptions9-4
Table 9-5	Second Module Base Address Register (MBAR2)9-5
Table 9-6	Second Module Base Address Bit Descriptions9-5
Table 9-7	DeviceID Register (DeviceID)9-6
Table 9-8	Primary Interrupt Control Register Memory Map9-7
Table 9-9	Interrupt Control Register (ICR)9-7
Table 9-10	Interrupt Control Bit Descriptions9-7
Table 9-11	Interrupt Priority Scheme9-8
Table 9-12	Interrupt Priority Assignment9-8
Table 9-13	Interrupt Mask Register (IMR)9-9
Table 9-14	Interrupt Mask Bit Descriptions9-10
Table 9-15	Interrupt Pending Register (IPR)9-10
Table 9-16	Interrupt Pending Bit Descriptions9-10
Table 9-17	Secondary Interrupt Controller Registers Memory Map9-11
Table 9-18	Secondary Interrupt Level Programming Bit Assignment9-11
Table 9-19	intBase Register Description9-12
Table 9-20	intBase Bit Descriptions9-12
Table 9-21	spurvec Register Description9-12
Table 9-22	Secondary Interrupt Sources9-12
Table 9-23	FlashMedia Interrupt Interface9-14
Table 9-24	Extraint Register Descriptions9-15
Table 9-25	Reset Status Register (RSR)9-16
Table 9-26	Reset Status Bit Descriptions9-16
Table 9-27	System Protection Control Register (SYPCR)9-18
Table 9-28	System Protection Control Bit Descriptions9-18
Table 9-29	SWT Timeout Period9-18

Table 9-30	SWP and SWT Bit Descriptions	9-19
Table 9-31	Software Watchdog Interrupt Vector Register (SWIVR)	9-19
Table 9-32	Software Watchdog Service Register (SWSR)	9-20
Table 9-33	Default Bus Master Register (MPARK)	9-20
Table 9-34	Default Bus Master Selected with PARK[1:0]	9-21
Table 9-35	Round Robin (PARK[1:0] = 00)	9-21
Table 9-36	Park on Master Core Priority (PARK[1:0] = 01)	9-22
Table 9-37	Park on Current Master Priority (PARK[1:0] = 11)	9-22
Table 9-38	Park Bit Descriptions	9-22
Table 9-39	GPIO Registers	9-23
Table 9-40	General Purpose Input to Pin Mapping	9-24
Table 9-41	GPIO-INT-STAT, GPIO-INT-CLEAR and GPIO-INT-EN Interrupts	9-25
Table 9-42	General-Purpose Output Register Bits to Pins Mapping	9-27
Table 10-1	Accesses by Matches in CS Control Registers	10-3
Table 10-2	Memory Map of Chip-Select Registers	10-5
Table 10-3	Chip Select Address Register (CSAR)	10-6
Table 10-4	Chip Select Bit Descriptions	10-6
Table 10-5	Chip Select Mask Register (CSMR)	10-7
Table 10-6	Chip Select Mask Bit Descriptions	10-7
Table 10-7	Chip Select Control Register 0	10-8
Table 10-8	Chip Select Control Register 1 to 3	10-9
Table 10-9	Chip Select Bit Descriptions	10-9
Table 11-1	Programming Model for Timers	11-3
Table 11-2	Timer Mode Register (TMRn)	11-4
Table 11-3	Timer Mode Bit Descriptions	11-4
Table 11-4	Timer Reference Register (TRRn)	11-5
Table 11-5	Timer Capture Register (TCR)	11-6
Table 11-6	Timer Counter (TCN)	11-6
Table 11-7	Timer Event Register (TERn)	11-6
Table 11-8	Timer Event Bit Descriptions	11-7
Table 12-1	ADC Registers	12-2
Table 12-2	ADconfig (ADconfig) Register	12-3
Table 12-3	ADconfig Register Bit Descriptions	12-3
Table 12-4	ADvalue Register	12-4
Table 12-5	ADvalue Register Bit Descriptions	12-4
Table 13-1	ideconfig1 Register	13-3
Table 13-2	IDECONFIG1 Bits	13-3
Table 13-3	IDEConfig Register	13-5
Table 13-4	IDEConfig Bit Description	13-5
Table 13-5	DIOR, DIOW, and IORDY Timing Parameters	13-6
Table 13-6	SmartMedia Timing Values	13-7
Table 13-7	IDE Timing Values	13-9
Table 13-8	FlashMedia Registers	13-11
Table 13-9	FLASHMEDIACONFIG Register Configuration	13-11
Table 13-10	FLASHMEDIA COMMAND REGISTERS (MemoryStick Mode)	13-13
Table 13-11	FLASHMEDIA COMMAND REGISTER 1 (Secure Digital Mode)	13-13
Table 13-12	FLASHMEDIA COMMAND REGISTER 2 (Secure Digital Mode)	13-14
Table 13-13	FLASHMEDIA DATA REGISTERS	13-15
Table 13-14	FLASHMEDIA STATUS REGISTER	13-15
Table 13-15	FLASHMEDIA INTERRUPTS	13-16
Table 14-1	DMA Signals	14-2

List of Tables

		Page Number
Table 14-2	Memory Map DMA Channel 0	14-4
Table 14-3	Memory Map DMA Channel 1	14-4
Table 14-4	Memory Map DMA Channel 2	14-4
Table 14-5	Memory Map DMA Channel 3	14-4
Table 14-6	Memory Map (DMA Controller Registers —BCR24BIT = 1)	14-5
Table 14-7	DMAroute Register	14-5
Table 14-8	DMAroute Register Fields	14-5
Table 14-9	DMA3REQ Field Definition	14-6
Table 14-10	DMA2REQ Field Definition	14-6
Table 14-11	DMA1REQ Field Definition	14-7
Table 14-12	DMA0REQ Field Definition	14-8
Table 14-13	Source Address Register (SAR)	14-8
Table 14-14	Destination Address Register (DAR)	14-9
Table 14-15	Byte Count Register (BCR)—BCR24BIT = 1	14-10
Table 14-16	Byte Count Register (BCR)—BCR24BIT = 0	14-10
Table 14-17	DMA Control Register (DCR)—BCR24BIT = 0	14-10
Table 14-18	DMA Control Bit Descriptions	14-11
Table 14-19	BWC Encoding	14-12
Table 14-20	SSIZE Encoding	14-13
Table 14-21	DSIZE Encoding	14-13
Table 14-22	DMA Status Register (DSR)	14-14
Table 14-23	DMA Status Bit Descriptions	14-14
Table 14-24	DMA Interrupt Vector Register (DIVR)	14-15
Table 15-1	UART Module Programming Model	15-13
Table 15-2	Mode Register 1	15-13
Table 15-3	PMx and PT Control Bits	15-14
Table 15-4	Mode Register 1 Bit Descriptions	15-14
Table 15-5	B/Cx Control Bits	15-15
Table 15-6	Mode Register 2	15-15
Table 15-7	Mode Register 2 Bit Descriptions	15-16
Table 15-8	Status Registers (USR0 and USR1)	15-18
Table 15-9	Status Bit Descriptions	15-18
Table 15-10	Clock Select Register (UCSRn)	15-19
Table 15-11	Clock Select Bit Descriptions	15-20
Table 15-12	Command Register (UCRn)	15-20
Table 15-13	MISCx Control Bits	15-20
Table 15-14	RCx Control Bits	15-22
Table 15-15	TCx Control Bits	15-22
Table 15-16	Receiver Buffer (URBn)	15-23
Table 15-17	Receiver Buffer Bit Descriptions	15-23
Table 15-18	Transmitter Buffer (UTBn)	15-23
Table 15-19	Transmitter Buffer Bit Descriptions	15-24
Table 15-20	Input Port Change Register (UIPCRn)	15-24
Table 15-21	Input Port Change Bit Descriptions	15-24
Table 15-22	Auxiliary Control Register (UACRn)	15-25
Table 15-23	Auxiliary Control Bit Descriptions	15-25
Table 15-24	Interrupt Status Register (UISRn)	15-25
Table 15-25	Interrupt Status Bit Descriptions	15-26
Table 15-26	Interrupt Mask Register (UIMRn)	15-26
Table 15-27	Interrupt Mask Bit Descriptions	15-27
Table 15-28	Interrupt Vector Register (UIVRn)	15-27

Table 15-29	Interrupt Vector Bit Descriptions	15-28
Table 15-30	Input Port Register (UIPn)	15-28
Table 15-31	Interrupt Vector Bit Descriptions	15-28
Table 15-32	Output Port Data Registers (UOP1n)	15-28
Table 15-33	Output Port Data Bit Descriptions	15-29
Table 15-34	Output Port Data Registers (UOP0n)	15-29
Table 16-1	QSPI Input and Output Signals and Functions	16-2
Table 16-2	QSPI_CLK Frequency as Function of CPU Clock and Baud Rate	16-6
Table 16-3	QSPIMR Field Descriptions	16-8
Table 16-4	QDLYR Field Descriptions	16-10
Table 16-5	QWR Field Descriptions	16-11
Table 16-6	QIR Field Descriptions	16-12
Table 16-7	QCR0–QCR15 Field Descriptions	16-14
Table 17-1	Interrupt Register Addresses	17-4
Table 17-2	Interrupt Register Description	17-4
Table 17-3	InterruptEn3 InterruptClear3, InterruptStat3 Register Description	17-5
Table 17-4	IIS1 Configuration Registers (0x10)	17-6
Table 17-5	IIS2 Configuration Registers (0x14)	17-6
Table 17-6	IIS3,4 Configuration Registers (0x18, 0x1C)	17-6
Table 17-7	IIS Configuration Bit Descriptions	17-7
Table 17-8	EBU1Config Register	17-10
Table 17-9	EBU1Config Register Bit Descriptions	17-11
Table 17-10	EBU2Config Register	17-12
Table 17-11	EBU2Config Register Bit Descriptions	17-12
Table 17-12	EBURcvCChannel Register	17-13
Table 17-13	UChannel Receive and QChannel Receive Registers	17-15
Table 17-14	U Channel Receive and Q Channel Receive Bit Descriptions	17-15
Table 17-15	CDTEXTCONTROL	17-15
Table 17-16	CD-Subcode Register Bit Descriptions	17-15
Table 17-17	Correlation Between Zero Bits and Sync Symbols	17-17
Table 17-18	EBU1TxCChannel Registers Addresses	17-19
Table 17-19	Formatting of EBUOUT1 (Consumer “C” channel)	17-19
Table 17-20	Formatting of EBUOUT2 - Professional “C” Channel	17-19
Table 17-21	UChannel Transmit Register	17-20
Table 17-22	CD-Subcode Register	17-20
Table 17-23	Data Exchange Register Descriptions	17-23
Table 17-24	DataInControl Register	17-25
Table 17-25	DataInControl Bit Descriptions	17-25
Table 17-26	PDIR1-L, PDIR3-L, PDOR1-L, PDOR2-L Formatting	17-27
Table 17-27	PDIR1-R, PDIR3-R, PDOR1-R, PDOR2-R Formatting	17-27
Table 17-28	PDIR2, PDOR3 Formatting	17-27
Table 17-29	audioGlob Register	17-28
Table 17-30	audioGlob Register Fields (0xCE)	17-29
Table 17-31	Interrupt Register Description (0x94, 0x98)	17-31
Table 17-32	blockControl Register	17-33
Table 17-33	blockControl Bit Descriptions	17-34
Table 17-34	Swap Control in CD-ROM Encoder/Decoder	17-35
Table 17-35	DMA Config Register Address	17-37
Table 17-36	DMA Config Bit Descriptions	17-37
Table 17-37	PhaseConfig and Frequency Measure Register Addresses	17-38
Table 17-38	PhaseConfig Register	17-39

Freescale Semiconductor, Inc.

List of Tables

	Page Number
Table 17-39	PhaseConfig Bit Descriptions 17-39
Table 17-40	PhaseConfig Register Description (0xA0) 17-39
Table 17-41	XTrim Register Address and Description 17-40
Table 17-42	Audio Interface Memory Map 17-41
Table 18-1	I2C Interfaces Programmer's Model 18-5
Table 18-2	MADR Register 18-6
Table 18-3	MADR Bit Descriptions 18-6
Table 18-4	MFDR Register 18-7
Table 18-5	MFDR Bit Descriptions 18-7
Table 18-6	I2C Prescaler Values 18-7
Table 18-7	MBCR Register 18-8
Table 18-8	MBCR Bit Descriptions 18-9
Table 18-9	MBSR Register 18-10
Table 18-10	MBSR Bit Descriptions 18-10
Table 18-11	MBDR Register 18-11
Table 19-1	Processor Status Encoding 19-3
Table 19-2	Receive BDM Packet 19-8
Table 19-3	CPU-Generated Command Responses 19-8
Table 19-4	Receive BDM Bit Descriptions 19-9
Table 19-5	Transmit BDM Packet 19-9
Table 19-6	Transmit Bit Descriptions 19-9
Table 19-7	BDM Command Summary 19-10
Table 19-8	BDM Command Format 19-11
Table 19-9	BDM Bit Descriptions 19-11
Table 19-10	BDM Size Field Encoding 19-11
Table 19-11	WAREG/WDREG Command 19-14
Table 19-12	Byte FILL Command 19-19
Table 19-13	Word FILL Command 19-19
Table 19-14	Long FILL Command 19-19
Table 19-15	GO Command 19-20
Table 19-16	NOP Command 19-20
Table 19-17	RC Encoding 19-21
Table 19-18	Definition of DRc Encoding--Read 19-23
Table 19-19	Definition of DRc Encoding--Write 19-24
Table 19-20	DDATA[3:0], CSR[31:28] Breakpoint Response 19-26
Table 19-21	Shared BDM/Breakpoint Hardware 19-28
Table 19-22	Address Breakpoint Low Register (ABLR) 19-29
Table 19-23	Address Breakpoint High Register (ABHR) 19-29
Table 19-24	Address Attribute Trigger Register (AATR) 19-30
Table 19-25	Address Attribute Trigger Bit Descriptions 19-30
Table 19-26	Program Counter Breakpoint Register (PBR) 19-32
Table 19-27	Program Counter Breakpoint Mask Register (PBMR) 19-32
Table 19-28	Data Breakpoint Register (DBR) 19-33
Table 19-29	Data Breakpoint Mask Register (DBMR) 19-33
Table 19-30	Access and Operand Data Location 19-34
Table 19-31	Trigger Definition Register (TDR) 19-35
Table 19-32	Trigger Definition Bit Descriptions 19-35
Table 19-33	Configuration/Status Register (CSR) 19-37
Table 19-34	Configuration/Status Bit Descriptions 19-37
Table 19-35	BDM Address Attribute Register (BAAR) 19-39
Table 19-36	BDM Address Attribute (BAAR) Bit Descriptions 19-40

	Page Number
Table 20-1	JTAG Pin Descriptions 20-3
Table 20-2	JTAG Instructions 20-6
Table 20-3	ID Code Register Command 20-8
Table 20-4	ID Code Bit Descriptions 20-8
Table 21-1	Maximum Ratings 21-1
Table 21-2	Operating Temperature 21-1
Table 21-3	DC Electrical Specifications (V _{cc} = 3.3 V _{dc} + 0.3 V _{dc}) 21-2
Table 21-4	160 MAPBGA Ball Assignments 21-5
Table 21-5	Clock Timing Specification 21-6
Table 21-6	Input AC Timing Specification 21-7
Table 21-7	Output AC Timing Specification 21-7
Table 21-8	Debug AC Timing Specification 21-10
Table 21-9	Timer Module AC Timing Specification 21-11
Table 21-10	UART Module AC Timing Specifications 21-12
Table 21-11	I ² C-Bus Input Timing Specifications Between SCL and SDA 21-13
Table 21-12	I ² C-Bus Output Timing Specifications Between SCL and SDA 21-13
Table 21-13 21-14
Table 21-14	General-Purpose I/O Port AC Timing Specifications 21-15
Table 21-15	IEEE 1149.1 (JTAG) AC Timing Specifications 21-16
Table 21-16	SCLK INPUT, SDATA0 OUTPUT Timing Specifications 21-18
Table 21-17	SCLK OUTPUT, SDATA0 OUTPUT Timing Specifications 21-18
Table 21-18	SCLK INPUT, SDATA1 INPUT Timing Specifications 21-19
Table 22-1	144 QFP Pin Assignments 22-2
Table 22-2	160 MAPBGA Pins 22-6
Table 22-3	160 MAPBGA Pin Assignments 22-7
Table A-1	CPU Memory Map A-1
Table A-2	MBAR Address Space Memory Map A-1
Table A-3	Audio Interface Memory Map A-4
Table A-4	GPIO and Interrupt Status Memory Map A-6
	A/D, MBUS2 and Memory Stick Memory Map A-7

Intentionally
Left
Blank

Section 1

Introduction

1.1 MCF5249 OVERVIEW

This document provides an overview of the MCF5249 ColdFire® processor and general descriptions of the MCF5249 features and modules.

The MCF5249 was designed as a system controller/decoder for MP3 music players, especially portable MP3 CD players. The 32-bit ColdFire core with Enhanced Multiply Accumulate (EMAC) unit provides optimum performance and code density for the combination of control code and signal processing required for MP3 decode, file management, and system control.

Low power features include a hardwired CD ROM decoder, advanced 0.18um CMOS process technology, 1.8V core power supply, and on-chip 96KByte SRAM. MP3 decode requires less than 20MHz CPU bandwidth and runs in on-chip SRAM with external access only for data input and output.

The MCF5249 is also an excellent general purpose system controller with over 125 Dhrystone 2.1 MIPS @ 140MHz performance at a very competitive price. The integrated peripherals and EMAC allow the MCF5249 to replace both the microcontroller and the DSP in certain applications. Most peripheral pins can also be remapped as General Purpose I/O pins.

1.2 MCF5249 FEATURE INTRODUCTION

The MCF5249 integrated microprocessor combines a Version 2 ColdFire® processor core operating at 140MHz with the following modules.

- DMA controller with 4 DMA channels
- Integrated Enhanced Multiply-accumulate Unit (EMAC)
- 8-KByte Direct Mapped Instruction Cache
- 96-KByte SRAM (A 64K and a 32K bank)
- Operates from external crystal oscillator
- Supports 16-bit wide SDRAM memories
- Serial Audio Interface which supports IIS and EIAJ audio protocols
- Digital audio transmitter and two receivers compliant with IEC958 audio protocol
- CD-ROM and CD-ROM XA block decoding and encoding function
- Two UARTS
- Queued Serial Peripheral Interface (QSPI) (Master Only)
- Two timers
- IDE and SmartMedia interfaces
- Analog/Digital Converter
- Flash Memory Card Interface
- Two I²C modules¹
- System debug support
- General Purpose I/O pins shared with other functions

1. I²C is a proprietary Philips bus.

MCF5249 Block Diagram

- 1.8V core, 3.3V I/O
- 160 pin MAPBGA package (qualified at 140 MHz) and 144 pin QFP package (qualified at 120 MHz)

1.3 MCF5249 BLOCK DIAGRAM

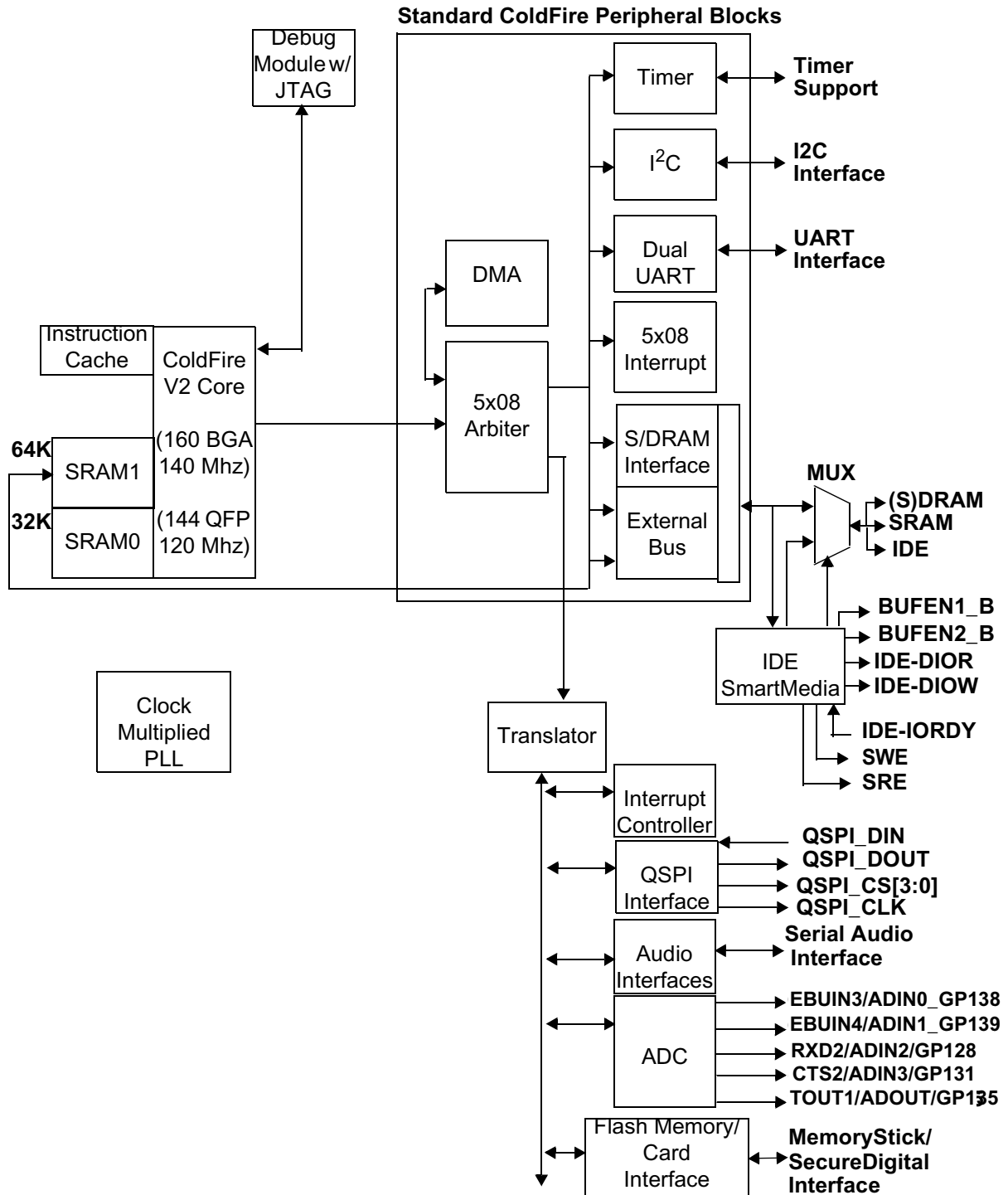

Figure 1-1 MCF5249 Block Diagram

1.4 MCF5249 FEATURE DETAILS

The primary features of the MCF5249 integrated processor include the following:

- ColdFire V2 Processor Core operating at 140MHz
 - Clock-doubled Version 2 microprocessor core
 - 32-bit internal data bus, 16 bit external data bus
 - 16 user-visible, 32-bit general-purpose registers
 - Supervisor/user modes for system protection
 - Vector base register to relocate exception-vector table
 - Optimized for high-level language constructs
- DMA controller
 - Four fully programmable channels: Two dedicated to the audio interface module and two dedicated to the UART module (External requests are not supported.)
 - Supports dual- and single-address transfers with 32-bit data capability
 - Two address pointers that can increment or remain constant
 - 16-/24-bit transfer counter
 - Operand packing and unpacking support
 - Auto-alignment transfers supported for efficient block movement
 - Supports bursting and cycle stealing
 - All channels support memory to memory transfers
 - Interrupt capability
 - Provides two clock cycle internal access
- Enhanced Multiply-accumulator Unit
 - Single-cycle multiply-accumulate operations for 32 x 32 bit and 16 x 16 bit operands
 - Support for signed, unsigned, integer, and fixed-point fractional input operands
 - Four 48-bit accumulators to allow the use of a 40-bit product
 - The addition of 8 extension bits to increase the dynamic number range
 - Fast signed and unsigned integer multiplies
- 8-KByte Direct Mapped instruction cache
 - Clocked at core clock frequency
 - Flush capability
 - Non-blocking cache provides fast access to critical code and data
- 96-KByte SRAM
 - Provides one-cycle access to critical code and data
 - Split into two banks, SRAM0 (32K), and SRAM1 (64K)
 - DMA requests to/from internal SRAM1 supported
- Crystal Trim
 - The XTRIM output can be used to trim an external crystal oscillator circuit which would allow lock with an incoming IEC958 or serial audio signal
- Audio Interfaces
 - IEC958 input and output
 - Four serial Philips IIS/Sony EIAJ interfaces
 - One with input and output, one with output only, two with input only (Three inputs, two outputs)
 - Master and Slave operation

- CD Text Interface
 - Allows the interface of CD subcode (transmitter only)
- Dual Universal Synchronous/Asynchronous Receiver/Transmitter (Dual UART)
 - Full duplex operation
 - Baud-rate generator
 - Modem control signals: clear-to-send (CTS) and request-to-send (RTS)
 - DMA interrupt capability
 - Processor-interrupt capability
- Queued Serial Peripheral Interface (QSPI)
 - Programmable queue to support up to 16 transfers without user intervention
 - Supports transfer sizes of 8 to 16 bits in 1-bit increments
 - Four peripheral chip-select lines for control of up to 15 devices
 - Baud rates from 273 Kbps to 15 Mbps at 140MHz
 - Programmable delays before and after transfers
 - Programmable clock phase and polarity
 - Supports wraparound mode for continuous transfers
 - Master mode only
- Dual 16-bit General-purpose Multimode Timers
 - Clock source selectable from external, CPU clock/2 and CPU clock/32.
 - 8-bit programmable prescaler
 - 2 timer inputs and 2 outputs
 - Processor-interrupt capability
 - 14.3 nS resolution with CPU clock at 140MHz
- IDE/ SmartMedia Interface
 - Allows direct connection to an IDE hard drive or other IDE peripheral
- Analog/Digital Converter
 - 12-Bit Resolution
 - 4 Muxed inputs
- Flash Memory Card Interface
 - Allows connection to Sony MemoryStick compatible devices
 - Support SD cards and other types of flash media
- Dual I²C Interfaces
 - Interchip bus interface for EEPROMs, LCD controllers, A/D converters, keypads
 - Master and slave modes, support for multiple masters
 - Automatic interrupt generation with programmable level
- System debug support
 - Real-time instruction trace for determining dynamic execution path
 - Background debug mode (BDM) for debug features while halted
 - Debug exception processing capability
 - Real-time debug support

- System Interface
 - Glueless bus interface and DRAMC support for interface to 16-bit for DRAM, SRAM, ROM, FLASH, and I/O devices
 - Two programmable chip-select signals for static memories or peripherals with programmable wait states and port sizes.
 - Two dedicated chip selects for 16-bit wide DRAM/SDRAM.
 - CS0 is active after reset to provide boot-up from external FLASH/ROM.
 - Two dedicated chip selects (CS2 and CS3) are used for the IDE and/or SmartMedia interface
 - Programmable interrupt controller (low interrupt latency, eight external interrupt requests, programmable autovector generator)
 - 44 programmable general-purpose inputs (for the 160 MAPBGA package)
 - 46 programmable general-purpose outputs (for the 160 MAPBGA package)
 - IEEE 1149.1 Test (JTAG) Module
- Clocking
 - Clock-multiplied PLL, programmable frequency
- 1.8V Core, 3.3V I/O
- 160 pin MAPBGA package (qualified at 140 MHz) and 144 pin QFP package (qualified at 120 MHz)

1.5 160 MAPBGA BALL ASSIGNMENTS

The following signals are not available on the 144 QFP package.

Table 1-1 160 MAPBGA Ball Assignments

160 MAPBGA BALL NUMBER	FUNCTION	GPIO
E3	CMD_SDIO2	GPIO34
G4	SDATA0_SDIO1	GPIO54
H3	RSTO/SDATA2_BS2	
K3	A25	GPIO8
L4	QSPI_CS1	GPIO24
L8	QSPI_CS3	GPIO22
N8	SDRAM_CS2	GPIO7
P9	EBUOUT2	GPO 37
K11	BUFENB2	GPIO17
G12	SUBR	GPIO 53
F13	SFSY	GPIO 52
F12	RCK	GPIO 51
E8	SRE	GPIO11
B8	LRCK3	GPIO 45
E7	SWE	GPIO12
A7	SCLK3	GPIO 49

1.6 MCF5249 FUNCTIONAL OVERVIEW

1.6.1 COLDFIRE V2 CORE

The ColdFire processor Version 2 core consists of two independent, decoupled pipeline structures to maximize performance while minimizing core size. The instruction fetch pipeline (IFP) is a two-stage pipeline for prefetching instructions. The prefetched instruction stream is then gated into the two-stage operand execution pipeline (OEP), which decodes the instruction, fetches the required operands, and then executes the required function. Because the IFP and OEP pipelines are decoupled by an instruction buffer that serves as a FIFO queue, the IFP can prefetch instructions in advance of their actual use by the OEP, which minimizes time stalled waiting for instructions. The OEP is implemented in a two-stage pipeline featuring a traditional RISC data path with a dual-read-ported register file feeding an arithmetic/logic unit (ALU).

1.6.2 DMA CONTROLLER

The MCF5249 provides four fully programmable DMA channels for quick data transfer. Single and dual address mode is supported with the ability to program bursting and cycle stealing. Data transfer is selectable as 8, 16, 32, or 128-bits. Packing and unpacking is supported.

Two internal audio channels and the dual UART can be used with the DMA channels. All channels can perform memory to memory transfers. The DMA controller has a user-selectable, 24- or 16-bit counter and a programmable DMA exception handler.

External requests are not supported.

1.6.3 ENHANCED MULTIPLY AND ACCUMULATE MODULE (EMAC)

The integrated EMAC unit provides a common set of DSP operations and enhances the integer multiply instructions in the ColdFire architecture. The EMAC provides functionality in three related areas:

1. Faster signed and unsigned integer multiplies
2. New multiply-accumulate operations supporting signed and unsigned operands
3. New miscellaneous register operations

Multiplies of 16x16 and 32x32 with 48-bit accumulates are supported in addition to a full set of extensions for signed and unsigned integers plus signed, fixed-point fractional input operands. The EMAC has a single-clock issue for 32x32-bit multiplication instructions and implements a four-stage execution pipeline.

1.6.4 INSTRUCTION CACHE

The instruction cache improves system performance by providing cached instructions to the execution unit in a single clock. The MCF5249 processor uses a 8K-byte, direct-mapped instruction cache to achieve 125 MIPS at 140 Mhz. The cache is accessed by physical addresses, where each 16-byte line consists of an address tag and a valid bit. The instruction cache also includes a bursting interface for 16-bit and 8-bit port sizes to quickly fill cache lines.

1.6.5 INTERNAL 96-KBYTE SRAM

The 96-KByte on-chip SRAM is split over two banks, SRAM0 (64k) and SRAM1 (32K). It provides one clock-cycle access for the ColdFire core. This SRAM can store processor stack and critical code or data segments to maximize performance. Memory in the second bank can be accessed under DMA.

1.6.6 DRAM CONTROLLER

The MCF5249 DRAM controller provides a glueless interface for up to two banks of DRAM, each of which can be up to 32 MBytes. The controller supports a 16-bit data bus. A unique addressing scheme allows for increases in system memory size without rerouting address lines and rewiring boards. The controller operates in page mode, non-page mode, and burst-page mode and supports SDRAMs.

1.6.7 SYSTEM INTERFACE

The MCF5249 provides a glueless interface to 16-bit port size SRAM, ROM, and peripheral devices with independent programmable control of the assertion and negation of chip-select and write-enable signals.

The MCF5249 also supports bursting ROMs.

1.6.8 EXTERNAL BUS INTERFACE

The bus interface controller transfers information between the ColdFire core or DMA and memory, peripherals, or other devices on the external bus. The external bus interface provides 23 bits of address bus space, a 16-bit data bus, Output Enable, and Read/Write signals. This interface implements an extended synchronous protocol that supports bursting operations.

1.6.9 SERIAL AUDIO INTERFACES

The MCF5249 digital audio interface provides four serial Philips IIS/Sony EIAJ interfaces. One interface is a 4-pin (1 bit clock, 1 word clock, 1 data in, 1 data out), the other three interfaces are 3-pin (1 bit clock, 1 word clock, 1 data in or out). The serial interfaces have no limit on minimum sampling frequency. Maximum sampling frequency is determined by the maximum frequency on the bit clock input. (1/3 the frequency of the internal system clock.)

1.6.10 IEC958 DIGITAL AUDIO INTERFACES

The MCF5249 has two digital audio input interfaces, and one digital audio output interface. There are four digital audio input pins and two digital audio output pins. An internal multiplexer selects one of the four inputs to the digital audio input interface.

There is one digital audio output interface with two IEC958 outputs. One output carries the professional “c” channel (Channel Status), and the other carries the consumer “c” channel. All other bits (audio data, user channel bits, validity flag, etc) are identical.

The IEC958 output can take the output from the internal IEC958 generator, or multiplex out one of the four IEC958 inputs.

1.6.11 AUDIO BUS

The audio interfaces connect to an internal bus that carries all audio data. Each receiver places its received data on the audio bus and each transmitter takes data from the audio bus for transmission. Each transmitter has a source select register.

In addition to the audio interfaces, there are six CPU accessible registers connected to the audio bus. Three of these registers allow data reads from the audio bus and allow selection of the audio source. The other three registers provide a write path to the audio bus and can be selected by transmitters as the audio source. Through these registers, the CPU has access to the audio samples for processing.

Audio can be routed from a receiver to a transmitter without the data being processed by the core so the audio bus can be used as a digital audio data switch. The audio bus can also be used for audio format conversion.

1.6.12 CD-ROM ENCODER/DECODER

The MCF5249 is capable of processing CD-ROM sectors in hardware. Processing is compliant with CD-ROM and CD-ROM XA standards.

The CD-ROM decoder performs following functions in hardware:

- Sector sync recognition
- Descrambling of sectors
- Verification of the CRC checksum for Mode 1, Mode 2 Form 1, and Mode 2 Form 2 sectors
- Third-layer error correction is not performed

The CD-ROM encoder performs following functions in hardware:

- Sector sync recognition
- Scrambling of sectors
- Insertion of the CRC checksum for Mode 1, Mode 2 Form 1, and Mode 2 Form 2 sectors.
- Third-layer error encoding needs to be done in software. This can use approximately 5-10 Mhz of performance for single-speed.

1.6.13 DUAL UART MODULE

Two full-duplex UARTs with independent receive and transmit buffers are in this module. Data formats can be 5, 6, 7, or 8 bits with even, odd, or no parity, and up to 2 stop bits in 1/16 increments. Four-byte receive buffers and two-byte transmit buffers minimize CPU service calls. The Dual UART module also provides several error-detection and maskable-interrupt capabilities. Modem support includes request-to-send (RTS) and clear-to-send (CTS) lines.

The system clock provides the clocking function from a programmable prescaler. Users can select full duplex, auto-echo loopback, local loopback, and remote loopback modes. The programmable Dual UARTs can interrupt the CPU on various normal or error-condition events.

1.6.14 QUEUED SERIAL PERIPHERAL INTERFACE QSPI

The QSPI module provides a serial peripheral interface with queued transfer capability. It supports up to 16 stacked transfers at a time, making CPU intervention between transfers unnecessary. Transfers of up to 17.5 Mbits/second are possible at a CPU clock of 140 MHz. The QSPI supports master mode operation only.

1.6.15 TIMER MODULE

The timer module includes two general-purpose timers, each of which contains a free-running 16-bit timer for use in any of three modes:

1. Input Capture. This mode captures the timer value with an external event.
2. Output Compare. This mode triggers an external signal or interrupts the CPU when the timer reaches a set value
3. Event Counter. This mode counts external events.

The timer unit has an 8-bit prescaler that allows programming of the clock input frequency, which is derived from the system clock. In addition to the $\div 1$ and $\div 16$ clock derived from the bus clock (CPU clock / 2), the programmable timer-output pins either generate an active-low pulse or toggle the outputs.

1.6.16 IDE AND SMARTMEDIA INTERFACES

The MCF5249 system bus allows connection of an IDE hard disk drive and SmartMedia flash card with a minimum of external hardware. The external hardware consists of bus buffers for address and data and are intended to reduce the load on the bus and prevent SDRAM and Flash accesses to propagate to the IDE bus. The control signals for the buffers are generated in the MCF5249.

1.6.17 ANALOG/DIGITAL CONVERTER (ADC)

The four channel ADC is based on the Sigma-Delta concept with 12-bit resolution. The digital portion of the ADC is provided internally. The analog voltage comparator must be provided externally as well as an external integrator circuit (resistor/capacitor) which is driven by the ADC output. A software interrupt is provided when the ADC measurement cycle is complete.

1.6.18 FLASH MEMORY CARD INTERFACE

The interface is Sony MemoryStick and SecureDigital compatible. However, there is no hardware support for MagicGate™.

1.6.19 I²C MODULE

The two-wire I²C bus interface, which is compliant with the Philips I²C bus standard, is a bidirectional serial bus that exchanges data between devices. The I²C bus minimizes the interconnection between devices in the end system and is best suited for applications that need occasional bursts of rapid communication over short distances among several devices. Bus capacitance and the number of unique addresses limit the maximum communication length and the number of devices that can be connected.

1.6.20 CHIP-SELECTS

There are four programmable chip selects on the MCF5249:

- Two programmable chip-select outputs (CS0 and CS1) provide signals that enable glueless connection to external memory and peripheral circuits. The base address, access permissions, and automatic wait-state insertion are programmable with configuration registers. These signals also interface to 16-bit ports.
- Two dedicated chip selects (CS2 and CS3) are used for the IDE and/or SmartMedia interface

CS0 is active after reset to provide boot-up from external FLASH/ROM.

1.6.21 GPIO INTERFACE

A total of 44 General Purpose inputs and 46 General Purpose outputs are available. These are multiplexed with various other signals. Eight of the GPIO inputs have edge sensitive interrupt capability.

1.6.22 INTERRUPT CONTROLLER

The MCF5249 has a primary and a secondary interrupt controller. These interrupt controllers handle interrupts from all internal interrupt sources. In addition, there are 8 GPIOs where external interrupts can

be generated on the rising or falling edge of the pin. All interrupts are autovectored and interrupt levels are programmable.

1.6.23 JTAG

To help with system diagnostics and manufacturing testing, the MCF5249 includes dedicated user-accessible test logic that complies with the IEEE 1149.1A standard for boundary scan testability, often referred to as Joint Test Action Group, or JTAG. For more information, refer to the IEEE 1149.1A standard. Motorola provides BSDL files for JTAG testing.

1.6.24 SYSTEM DEBUG INTERFACE

The ColdFire processor core debug interface supports real-time instruction trace and debug, plus background-debug mode. A background-debug mode (BDM) interface provides system debug.

In real-time instruction trace, four status lines provide information on processor activity in real time (PST pins). A four-bit wide debug data bus (DDATA) displays operand data and change-of-flow addresses, which helps track the machine's dynamic execution path.

1.6.25 CRYSTAL AND ON-CHIP PLL

Typically, an external 16.92 Mhz or 33.86 Mhz clock input is used for CD R/W applications, while an 11.2896 MHz clock is more practical for Portable CD player applications. However, the on-chip programmable PLL, which generates the processor clock, allows the use of almost any low frequency external clock (5-35 Mhz).

Two clock outputs (MCLK1 and MCLK2) are provided for use as Audio Master Clock. The output frequencies of both outputs are programmable to F_{xtal} , $F_{xtal}/2$, $F_{xtal}/3$, and $F_{xtal}/4$. The $F_{xtal}/3$ option is only available when the 33.86 Mhz crystal is connected.

The MCF5249 supports VCO operation of the oscillator by means of a 16-bit pulse density modulation output. Using this mode, it is possible to lock the oscillator to the frequency of an incoming IEC958 or IIS signal. The maximum trim depends on the type and design of the oscillator. Typically a trim of +/- 100 ppm can be achieved with a crystal oscillator and over +/- 1000 ppm with an LC oscillator.

Section 2 Signal Description

2.1 INTRODUCTION

This section describes the MCF5249 input and output signals. The signal descriptions as shown in [Table 2-1](#) are grouped according to relevant functionality.

Table 2-1 MCF5249 Signal Index

SIGNAL NAME	MNEMONIC	FUNCTION	INPUT/ OUTPUT	RESET STATE
Address	A[23:1] A[25]/GPO8	23 address bus lines, address line 25 multiplexed with gpo8	Out	X
Read-write control	RW_b	Bus write enable - indicates if read or write cycle in progress	Out	H
Output enable	OE	Output enable for asynchronous memories connected to chip selects	Out	negated
Data	D[31:16]	Data bus used to transfer word data	In/Out	Hi-Z
Synchronous row address strobe	SDRAS	Row address strobe for external SDRAM.	Out	negated
Synchronous column address strobe	SDCAS	Column address strobe for external SDRAM	Out	negated
SDRAM write enable	SDWE	Write enable for external SDRAM	Out	negated
SDRAM upper byte enable	SDUDQM	Indicates during write cycle if high byte is written	Out	
SDRAM lower byte enable	SDLDQM	Indicates during write cycle if low byte is written	Out	
SDRAM chip selects	SDRAMCS1	SDRAM chip select	Out	negated
SDRAM chip selects	SDRAMCS2/GPIO7	SDRAM chip select	In/Out	negated
SDRAM clock enable	BCLKE	SDRAM clock enable	Out	
System clock	SCLK/GPIO10	SDRAM clock output	In/Out	
ISA bus read strobes	CS2/IDE-DIOR/GPIO13 CS3/SRE/GPIO11	There are 2 ISA bus read strobes and 2 ISA bus write strobes. They Allow connection of two independent ISA bus peripherals, e.g. an IDE slave device and a SmartMedia card	In/Out	
ISA bus write strobes	IDE-DIOW/GPIO14 SWE/GPIO12		In/Out	
ISA bus wait signal	IDE-IORDY/GPIO16	ISA bus wait line - available for both busses	In/Out	
Chip Selects[1:0]	$\overline{CS0}$ CS1/GPIO58	Enables peripherals at programmed addresses. $\overline{CS[1:0]}$. $\overline{CS[0]}$ provides boot ROM selection	Out In/Out	negated
Buffer enable 1	$\overline{BUFENB1}$ /GPIO57	Two programmable buffer enables Allow seamless steering of external buffers to split data and address bus in sections.	In/Out	
Buffer enable 2	$\overline{BUFENB2}$ /GPIO7		In/Out	
Transfer acknowledge	TA/GPIO20	Transfer Acknowledge signal	In/Out	

Table 2-1 MCF5249 Signal Index (Continued)

SIGNAL NAME	MNEMONIC	FUNCTION	INPUT/ OUTPUT	RESET STATE
Serial Clock line	SCL0/QSPI_CLK	Clock signal for first I ² C module operation Signal is also QSPI clock	In/Out	
Serial Data Line	SDA0/QSPI_DIN	Serial data port first I ² C module operation Signal is also QSPI data in	In/Out	
Serial Clock Line	SCL1_GPIO3	Clock signal for second I ² C module operation	In/Out	
Serial Data Line	SDA1_GPIO55	Serial data port for second I ² C module operation	In/Out	
Receive Data	RXD1/GPI28/ADIN2 RXD0/GPI27	Signal is receive serial data input for DUART	In	
Transmit Data	TXD1/GPO28 TXD0/GPO27	Signal is transmit serial data output for DUART	Out	asserted
Request-To-Send	RTS1/GPO31 RTS2/GPO30	DUART signals a ready to receive data query	Out	negated
Clear-To-Send	CTS1/ADIN3/GPI31 CTS0/GPI30	Signals to DUART that data can be transmitted to peripheral CTS2 is multiplexed with an A/D input	In	
Timer Input	TIN0/GPI33 TIN1/GPIO23	Provides clock input to timer or provides trigger to timer value capture logic	In In/Out	
Timer Output	TOUT0/GPO33 TOUT1/ADOUT/GPO35	Capable of output waveform or pulse generation	Out	
IEC958 inputs	EBUIN1/GPI36 EBUIN2/GPI37 EBUIN3/ADIN0/GPI38 EBUIN4/ADIN1/GPI39	Audio interfaces IEC958 inputs multiplexed with some A/D inputs	In	
IEC958 outputs	EBUOUT1/GPO36 EBUOUT2/GPO37	Audio interfaces IEC958 outputs	Out	
Serial data in	SDATAI1 SDATAI3/GPI41 SDATAI4/GPI42	Audio interfaces serial data inputs	In	
Serial data out	SDATAO1/GPIO25 SDATAO2/GPO41	Audio interfaces serial data outputs	In/Out Out	
Word clock	LRCK1 LRCK2/GPIO44 LRCK3/GPIO45 LRCK4/GPIO46	Audio interfaces serial word clocks	In/Out	
Bit clock	SCLK1 SCLK2/GPIO48 SCLK3/GPIO49 SCLK4/GPIO50	Audio interfaces serial bit clocks	In/Out	
Serial input	EF/GPIO19	Error flag serial in	In/Out	
Serial input	CFLG/GPIO18	C-flag serial in	In/Out	

Table 2-1 MCF5249 Signal Index (Continued)

SIGNAL NAME	MNEMONIC	FUNCTION	INPUT/ OUTPUT	RESET STATE
Subcode clock	RCK/GPIO51	Audio interfaces subcode clock	In/Out	
Subcode sync	SFSY/GPIO52	Audio interfaces subcode sync	In/Out	
Subcode data	SUBR/GPIO53	Audio interfaces subcode data	In/Out	
Clock frequency trim	XTRIM/GPO38	Clock trim control	Out	
Audio clocks out	MCLK1/GPO39 MCLK2/GPO42	DAC output clocks	Out	
MemoryStick/Secure Digital interface	CMDSDIO2/GPIO34	Secure Digital command lane MemoryStick interface 2 data i/o	In/Out	
	SCLKOUT/GPIO15	Clock out for both MemoryStick interfaces and for Secure Digital	In/Out	
	SDATA0_SDIO1/GPIO54	SecureDigital serial data bit 0 MemoryStick interface 1 data i/o	In/Out	
	SDATA1_BS1/GPIO9	SecureDigital serial data bit 1 MemoryStick interface 1 strobe	In/Out	
	RSTO/SDATA2_BS2	SecureDigital serial data bit 2 MemoryStick interface 2 strobe Reset output signal	In/Out	
	SDATA3/GPIO56	SecureDigital serial data bit 3	In/Out	
ADC	EBUIN3/ADIN0/GPI38 EBUIN4/ADIN1/GPI39 RXD2/ADIN2/GPI28 CTS2/ADIN3/GPI31	Analog to Digital converter input signals	In/Out	
ADC	TOUT1/ADOUT/GPO35	Analog to digital convertor output signal	In/Out	
QSPI clock	SCL/QSPI_CLK	QSPI clock signal	In/Out	
QSPI data in	SDA/QSPI_DIN	QSPI data input	In/Out	
QSPI data out	QSPIDOUT/GPIO26	QSPI data out	In/Out	
QSPI chip selects	QSPICS0/GPIO29 QSPICS1/GPIO24 QSPICS2/GPIO21 QSPICS3/GPIO22	QSPI chip selects	In/Out	
Crystal in	CRIN	Crystal input	In	
Reset In	RSTI	Processor Reset Input	In	
Motorola Test Mode	TEST[3:0]	Should always be low.	In	
High Impedance	HIZ	Assertion three-states all output signal pins.	In	
Debug Data	DDATA3/GPIO4 DDATA2/GPIO2 DDATA1/GPIO1 DDATA0/GPIO0	Displays captured processor data and break-point status.	In/Out	Hi-Z
Processor Status	PST3/GPIO62 PST2/GPIO61 PST1/GPIO60 PST0/GPIO59	Indicates internal processor status.	In/Out	Hi-Z
Processor clock	PSTCLK/GPO63	Processor clock output	Out	

Table 2-1 MCF5249 Signal Index (Continued)

SIGNAL NAME	MNEMONIC	FUNCTION	INPUT/ OUTPUT	RESET STATE
Test Clock	TCK	Clock signal for IEEE 1149.1A JTAG.	In	
Test Reset/Development Serial Clock	$\overline{\text{TRST}}/\text{DSCLK}$	Multiplexed signal that is asynchronous reset for JTAG controller. Clock input for debug module.	In	
Test Mode Select/ Break Point	$\text{TMS}/\overline{\text{BKPT}}$	Multiplexed signal that is test mode select in JTAG mode and a hardware break-point in debug mode.	In	
Test Data Input / Development Serial Input	TDI/DSI	Multiplexed serial input for the JTAG or background debug module.	In	
Test Data Output/Development Serial Output	TDO/DSO	Multiplexed serial output for the JTAG or background debug module.	Out	

Note: The CMD_SDIO2, SDATA0_SDIO1, RSTO/SDATA2_BS2, A25, QSPI_CS1, QSPI_CS3, SDRAM_CS2, EBUOUT2, BUFENB2, SUBR, SFSY, RCK, SRE, LRCK3, SWE, and the SCLK3 signals are only used in the 160 MAPBGA package.

2.2 GPIO

Many pins have a GPIO as first or second function. If gpio is second function, following rules apply:

- General purpose input is always active, regardless of state of pin.
- General purpose output or primary output is determined by value written to gpio function select register.
- Power-on reset function is not gpio

2.3 MCF5249 BUS SIGNALS

These signals provide the external bus interface to the MCF5249.

2.3.1 ADDRESS BUS

- The address bus provides the address of the byte or most significant byte of the word or longword being transferred. The address lines also serve as the DRAM address pins, providing multiplexed row and column address signals.
- Bits 23 down to 1 and 25 of the address are available. A25 is intended to be used with 256 Mbit DRAM's. Signals are named:
 - A[23:1]
 - A[25]/GPO8

2.3.2 READ-WRITE CONTROL

This signal indicates during any bus cycle whether a read or write is in progress. A low is write cycle and a high is a read cycle.

2.3.3 OUTPUT ENABLE

The \overline{OE} signal is intended to be connected to the output enable of asynchronous memories connected to chip selects. During bus read cycles, the ColdFire processor will drive \overline{OE} low.

2.3.4 DATA BUS

The data bus (D[31:16]) is bi-directional and non-multiplexed. Data is registered by the MCF5249 on the rising clock edge. The port width for each chip-select and DRAM bank are programmable. The data bus uses a default configuration if none of the chip-selects or DRAM bank match the address decode. All 16 bits of the data bus are driven during writes, regardless of port width or operand size.

2.3.5 TRANSFER ACKNOWLEDGE

The TA/GPIO20 pin is the transfer acknowledge signal.

2.4 SDRAM CONTROLLER SIGNALS

The following SDRAM signals provide a seamless interface to external SDRAM. An SDRAM width of 16 bits is supported and can access as much as 64 Mbytes of memory. ADRAMs are not supported.

Table 2-2 SDRAM Controller Signals

SDRAM SIGNAL	DESCRIPTION
synchronous DRAM row address strobe	The \overline{SDRAS} active low pin provides a seamless interface to the RAS input on synchronous DRAM
Synchronous DRAM Column Address Strobe	The \overline{SDCAS} active low pin provides a seamless interface to CAS input on synchronous DRAM.
Synchronous DRAM Write	The \overline{SDWE} active-low pin is asserted to signify that a SDRAM write cycle is underway. This pin outputs logic '1' during read bus cycles.
Synchronous DRAM Chip Enables	The $\overline{SDRAM_CS1}$ and $\overline{SDRAM_CS2/gpio7}$ active-low output signals are used during synchronous mode to route directly to the chip selects of up to 2 SDRAM devices. The $\overline{SDRAM_CS2/gpio7}$ can be programmed to be gpio using the GPIO-FUNCTION register.
Synchronous DRAM UDQM and LQDM signals	The DRAM byte enables UDMQ and LDQM are driven by the SDUDQM and SDLDQM byte enable outputs.
Synchronous DRAM clock	The DRAM clock is driven by the SCLK signal
Synchronous DRAM Clock Enable	The BCLKE active high output signal is used during synchronous mode to route directly to the SCKE signal of external SDRAMs. This signal provides the clock enable to the SDRAM.

Note: The SDRAM_CS2 signal is only used on the 160 MAPBGA package.

2.5 CHIP SELECTS

There are two chip select outputs on the MCF5249 device. $\overline{CS0}$ and $\overline{CS1/GPIO58}$. The second signal is multiplexed with a GPIO signal. The active low chip selects can be used to access asynchronous memories. The interface is glueless.

2.6 ISA BUS

The MCF5249 supports an ISA bus. (No ISA DMA channel). Using the ISA bus protocol, reads and writes to up to two ISA bus peripherals are possible. For the first peripheral, CS2/IDE-DIOR/GPIO13 and IDE-DIOW/GPIO14 are the read and write strobe. For the second peripheral, CS3/SRE/GPIO11 and SWE/GPIO12 are the read and write strobe. Either peripheral can insert wait states by pulling IDE-IORDY/GPIO16

2.7 BUS BUFFER SIGNALS

As the MCF5249 has a quite complicated slave bus, with the possibility to put DRAM on the bus, put asynchronous memories on the bus, and to put ISA bus peripherals on the bus, it may become necessary to introduce a bus buffer on the bus. The MCF5249 has a glueless interface to steer these bus buffers with 2 bus buffer output signals BUFENB1/GPIO57 and BUFENB2/GPIO7.

Note: The BUFENB2 signal is only used in the 160 MAPBGA package.

2.8 I²C MODULE SIGNALS

There are two I²C interfaces on this device.

The I²C module acts as a quick two-wire, bidirectional serial interface between the MCF5249 processor and peripherals with an I²C interface (e.g., LED controller, A-to-D converter, D-to-A converter). When devices connected to the I²C bus drive the bus, they will either drive logic-0 or high-impedance. This can be accomplished with an open-drain output.

Table 2-3 I²C Module Signals

I ² C MODULE SIGNAL	DESCRIPTION
I ² C Serial Clock	The SCL/QPSICLK and SCL2/GPIO3 bidirectional signals are the clock signal for first and second I ² C module operation. The I ² C module controls this signal when the bus is in master mode; all I ² C devices drive this signal to synchronize I ² C timing. Signals are multiplexed Function select is done via PLLCR register.
I ² C Serial Data	The SDA/QSPI_DIN and SDA2/GPIO55 bidirectional signals are the data input/output for the first and second serial I ² C interface. Signals are multiplexed Function select is done via PLLCR register.

2.9 SERIAL MODULE SIGNALS

The following signals transfer serial data between the two UART modules and external peripherals.

All serial module signals can be used as gpi or gpo. The GPIO-FUNCTION and GPIO1-FUNCTION registers must be programmed to determine pin functions of the inputs and outputs. If used as gpo or gpi, UART functionality is lost.

Table 2-4 Serial Module Signals

SERIAL MODULE SIGNAL	DESCRIPTION
Receive Data	The RXD1_GPI27 and RXD2/ADIN2/GPI28 are the inputs on which serial data is received by the DUART. Data is sampled on RxD[1:0] on the rising edge of the serial clock source, with the least significant bit received first.
Transmit Data	The DUART transmits serial data on the TXD1/GPO27 and TXD2/GPO28 output signals. Data is transmitted on the falling edge of the serial clock source, with the least significant bit transmitted (LSB) first. When no data is being transmitted or the transmitter is disabled, these two signals are held high. TxD[1:0] are also held high in local loopback mode.
Request To Send	The $\overline{\text{RTS1}}$ /GPO30 and $\overline{\text{RTS2}}$ /GPO31 request-to-send outputs indicate to the peripheral device that the DUART is ready to send data and requires a clear-to-send signal to initiate transfer.
Clear To Send	Peripherals drive the $\overline{\text{CTS1}}$ /GPI30 and $\overline{\text{CTS2}}$ /ADIN3/GPI31 inputs to indicate to the MCF5249 serial module that it can begin data transmission.

2.10 TIMER MODULE SIGNALS

The following signals are external interface to the two general-purpose MCF5249 timers. These 16-bit timers can capture timer values, trigger external events, or internal interrupts, or count external events.

These pins can be reused as GPO or GPI. Registers GPIO-FUNCTION and GPIO1-FUNCTION must be programmed for this.

Table 2-5 Timer Module Signals

SERIAL MODULE SIGNAL	DESCRIPTION
Timer Input	Users can program the TIN0/GPI33 and TIN1/GPIO23 inputs as clocks that cause events in the counter and prescalars. They can also cause capture on the rising edge, falling edge, or both edges.
Timer Output	The TOUT0/GPO33 and TOUT1/ADOUT/GPO35 programmable outputs pulse or toggle on various timer events.

2.11 SERIAL AUDIO INTERFACE SIGNALS

All serial audio interface signals can be programmed to serve as general purpose I/Os or as serial audio interface signals. The function is programmed using GPIO-FUNCTION and GPIO1-FUNCTION registers.

Note: The LRCK3 and SCLK3 signals are only used in the 160 MAPBGA package.

Table 2-6 Serial Audio Interface Signals

SERIAL MODULE SIGNAL	DESCRIPTION
Serial Audio Bit Clock	The SCLK1, SCLK2/GPIO48, SCLK3/GPIO49, AND SCLK4/GPIO50 multiplexed pins can serve as general purpose I/Os or serial audio bit clocks. As bit clocks, these bidirectional pins can be programmed as outputs to drive their associated serial audio (IIS) bit clocks. Alternately, these pins can be programmed as inputs when the serial audio bit clocks are driven internally. The functionality is programmed within the Audio module. During reset, these pins are configured as input serial audio bit clocks.
Serial Audio Word Clock	The LRCK1, LRCK2/GPIO44, LRCK3/GPIO45, AND LRCK4/GPIO46 multiplexed pins can serve as general purpose I/Os or serial audio word clocks. As word clocks, the bidirectional pins can be programmed as inputs to drive their associated serial audio word clock. Alternately, these pins can be programmed as outputs when the serial audio word clocks are derived internally. The functionality is programmed within the Audio module. During reset, these pins are configured as input serial audio word clocks.
Serial Audio Data In	The SDATAI1, SDATAI3/GPI41, SDATAI4/GPI42 multiplexed pins can serve as general purpose I/Os or serial audio inputs. As serial audio inputs the data is sent to interfaces 1,3 and 4 respectively. The functionality of these pins is programmed with the GPIO-FUNCTION and GPIO1-FUNCTION registers. During reset, the pins are configured as serial data inputs.
Serial Audio Data Out	The SDATAO1/GPIO25 AND SDATAO2/GPI41 multiplexed pins can serve as general purpose I/Os or serial audio outputs. The functionality of these pins is programmed with registers GPIO-FUNCTION and GPIO1-FUNCTION. During reset, the pins are configured as serial data outputs.
Serial audio error flag	The EF/GPIO19 multiplexed pin can serve as general purpose I/Os or error flag input. As error flag input, this pin will input the error flag delivered by the CD-DSP. EF/GPIO19 is only relevant for serial interface in 1
Serial audio CFLG	The CFLG/GPIO18 multiplexed pin can serve as general purpose I/O or CFLG input. As CFLG input, the pin will input the CFLG flag delivered by the CD-DSP. CFLG/GPIO18 is only relevant for serial interface in 1.

2.12 DIGITAL AUDIO INTERFACE SIGNALS

Table 2-7 Digital Audio Interface Signals

SERIAL MODULE SIGNAL	DESCRIPTION
Digital Audio In	The EBUIN1/GPI36, EBUIN2/GPI37, EBUIN3/ADIN0/GPI38, and EBUIN4/ADIN1/GPI39 multiplexed signals can serve as general purpose input or can be driven by various digital audio (IEC958) input sources. Both functionalities are always active. Input chosen for IEC958 receiver is programmed within the audio module. Input value on the 4 pins can always be read from the appropriate gpio register.
Digital Audio Out	The EBUOUT1_GPO36 and EBUOUT2_GPO37 multiplexed pins can serve as general purpose I/O or as digital audio (IEC958) output. EBUOUT1 is digital audio out for consumer mode, EBUOUT2 is digital audio out for professional mode. The functionality of the pins is programmed with the GPIO-FUNCTION and GPIO1-FUNCTION register. During reset, the pin is configured as a digital audio output.

Note: The EBUOUT2 signal is only used on the 160 MAPBGA package.

2.13 SUBCODE INTERFACE

There is a 3-line subcode interface on the MCF5249. This 3-line subcode interface allows the device to format and transmit subcode in EIAJ format to a CD channel encoder device. The three signals are described in [Table 2-8](#)

Table 2-8 Subcode Interface Signal

SIGNAL NAME	DESCRIPTION
RCK/GPIO51	Subcode clock input. When pin is used as subcode clock, this pin is driven by the CD channel encoder.
SFSY/GPIO52	Subcode sync output This signal is driven high if a subcode sync needs to be inserted in the EFM stream.
SUBR/GPIO53	Subcode data output This signal is a subcode data out pin.

Note: The SUBR, SFSY, and the RCK signals are only used in the 160 MAPBGA package.

2.14 ANALOG TO DIGITAL CONVERTER (ADC)

The single output on the TOUT1/ADOUT/GPO35 pin provides the reference voltage in PDM format therefore this output requires an external integrator circuit (resistor/capacitor) to convert it to a DC level to be used by the external comparator circuit.

Four external comparators compare the DC level obtained after filtering TOUT1/ADOUT/GPO35 with the relevant input signals. The outputs of the comparators are fed to the 4 ADIN inputs on the MCF5249: EBUIN3/ADIN0/GPI38, EBUIN4/ADIN1/GPI39, RXD2/ADIN2/GPI38 and CTS2/ADIN3/GPI31.

Selection of function for pin TOUT1/ADOUT/GPO35 is done by writing GPIO function select register (determines if function is GPIO or not), and differentiation between timer and adout functions is done in the ADCONFIG Register.

2.15 SECURE DIGITAL/ MEMORYSTICK CARD INTERFACE

The device has a versatile flash card interface that supports both SecureDigital and MemoryStick cards. The interface can either support one SecureDigital or two MemoryStick cards. No mixing of card types is possible. [Table 2-9](#) gives the pin descriptions.

Table 2-9 Flash Memory Card Signals

FLASH MEMORY SIGNAL	DESCRIPTION
SCLKOUT/GPIO15	Clock out for both MemoryStick interfaces and for SecureDigital
CMD_SDIO2/GPIO34	Secure Digital command line MemoryStick interface 2 data i/o
SDATA0_SDIO1/GPIO54	SecureDigital serial data bit 0 MemoryStick interface 1 data i/o
SDATA1_BS1/GPIO9	SecureDigital serial data bit 1 MemoryStick interface 1 strobe
RSTO/SDATA2_BS2	SecureDigital serial data bit 2 MemoryStick interface 2 strobe Reset output signal Selection between Reset function and SDATA2_BS2 is done by programming PLLCR register.
SDATA3/GPIO57	SecureDigital serial data bit 3

Note: The SDATA0_SDIO1 and RSTO/SDATA2_BS2 signals are only used in the 160 MAPBGA package.

2.16 QUEUED SERIAL PERIPHERAL INTERFACE (QSPI)

Table 2-10 Queued Serial Peripheral Interface (QSPI) Signals

SERIAL MODULE SIGNAL	DESCRIPTION
SCL_QSPICLK	Multiplexed signal IIC interface clock or QSPI clock output Function select is done via PLLCR register.
SDA_QSPIDIN	Multiplexed signal IIC interface data or QSPI data input. Function select is done via PLLCR register.
QSPIDOUT_GPIO26	QSPI data output
QSPICS0_GPIO29	4 different QSPI chip selects
QSPICS1_GPIO24	
QSPICS2_GPIO21	
QSPICS3_GPIO22	

Note: The CMD_SDIO2 signal is only used in the 160 MAPBGA package.

The QSPI interface is a high-speed serial interface allowing transmit and receive of serial data. Pin descriptions are given in [Table 2-10](#).

2.17 CRYSTAL TRIM

The XTRIM_GPO38 output produces a pulse-density modulated phase/frequency difference signal to be used after low-pass filtering to control varicap-voltage to control crystal oscillation frequency. This will lock the crystal to the incoming digital audio signal.

2.18 CLOCK OUT

The MCLK1/GPO39 and MCLK2/GPO42 can serve as general purpose I/Os or as DAC clock outputs. When programmed as DAC clock outputs, these signals are directly divided from the crystal.

2.19 DEBUG AND TEST SIGNALS

These signals interface with external I/O to provide processor status signals.

2.19.1 TEST MODE

The TEST[3:0] inputs are used for various manufacturing and debug tests. For normal mode these inputs should always be tied low. Use TEST0 to switch between background debug mode and JTAG mode. Drive TEST0 high for debug mode.

2.19.2 HIGH IMPEDANCE

The assertion of $\overline{\text{HI_Z}}$ will force all output drivers to a high-impedance state. The timing on $\overline{\text{HI_Z}}$ is independent of the clock.

Note: JTAG operation will override the $\overline{\text{HI_Z}}$ pin.

2.19.3 PROCESSOR CLOCK OUTPUT

The internal PLL generates this PSTCLK_GPO63 and output signal, and is the processor clock output that is used as the timing reference for the Debug bus timing (DDATA[3:0] and PST[3:0]). The PSTCLK_GPO63 is at the same frequency as the core processor and cache memory. The frequency will be twice the bus clock (SCLK) frequency.

2.19.4 DEBUG DATA

The debug data pins, DDATA0_GPIO0, DDATA1_GPIO1, DDATA2_GPIO2, and DDATA3_GPIO4, are four bits wide. This nibble-wide bus displays captured processor data and break-point status.

2.19.5 PROCESSOR STATUS

The processor status pins, PST0_GPIO59, PST1_GPIO60, PST2_GPIO61, and PST3_GPIO62, indicate the MCF5249 processor status. During debug mode, the timing is synchronous with the processor clock (PSTCLK) and the status is not related to the current bus transfer. [Table 2-11](#) shows the encodings of these signals.

Table 2-11 Processor Status Signal Encodings

PST[3:0]		DEFINITION
(HEX)	(BINARY)	
\$0	0000	Continue execution
\$1	0001	Begin execution of an instruction
\$2	0010	Reserved
\$3	0011	Entry into user-mode
\$4	0100	Begin execution of PULSE and WDDATA instructions
\$5	0101	Begin execution of taken branch or Synch_PC ¹
\$6	0110	Reserved
\$7	0111	Begin execution of RTE instruction
\$8	1000	Begin 1-byte data transfer on DDATA
\$9	1001	Begin 2-byte data transfer on DDATA
\$A	1010	Begin 3-byte data transfer on DDATA
\$B	1011	Begin 4-byte data transfer on DDATA
\$C	1100	Exception processing ²
\$D	1101	Emulator mode entry exception processing ²
\$E	1110	Processor is stopped, waiting for interrupt ²
\$F	1111	Processor is halted ²
<p>Note 1. Rev. B enhancement. Note 2. These encodings are asserted for multiple cycles.</p>		

2.20 BDM/JTAG SIGNALS

The MCF5249 complies with the IEEE 1149.1A JTAG testing standard. The JTAG test pins are multiplexed with background debug pins.

2.20.1 TEST CLOCK

TCK is the dedicated JTAG test logic clock that is independent of the MCF5249 processor clock. Various JTAG operations occur on the rising or falling edge of TCK. The internal JTAG controller logic is designed such that holding TCK high or low for an indefinite period of time will not cause the JTAG test logic to lose state information. If TCK will not be used, it should be tied to ground.

2.20.2 TEST RESET/DEVELOPMENT SERIAL CLOCK

The TEST[3:0] signals determine the function of the $\overline{\text{TRST}}$ /DSCLK dual-purpose pin. If TEST[3:0]=0001, the DSCLK function is selected. If TEST[3:0]= 0000, the TRST function is selected. TEST[3:0] should not be changed while $\overline{\text{RSTI}} = 1$. When used as $\overline{\text{TRST}}$, this pin will asynchronously reset the internal JTAG

controller to the test logic reset state, causing the JTAG instruction register to choose the “bypass” command. When this occurs, all the JTAG logic is benign and will not interfere with the normal functionality of the MCF5249 processor. Although this signal is asynchronous, Motorola recommends that $\overline{\text{TRST}}$ make only a 0 to 1 (asserted to negated) transition while TMS is held at a logic 1 value. $\overline{\text{TRST}}$ has an internal pullup so that if it is not driven low its value will default to a logic level of 1. However, if $\overline{\text{TRST}}$ will not be used, it can either be tied to ground or, if TCK is clocked, it can be tied to VDD. If it is tied to ground, it will place the JTAG controller in the test logic reset state immediately. If it is tied to VDD, it will cause the JTAG controller (if TMS is a logic 1) to eventually end up in the test logic reset state after 5 clocks of TCK.

This pin is also used as the development serial clock (DSCLK) for the serial interface to the Debug Module. The maximum frequency for the DSCLK signal is 1/5 the BCLKO frequency.

2.20.3 TEST MODE SELECT/BREAK POINT

The TEST[3:0] signals determine the TMS/ $\overline{\text{BKPT}}$ pin function. If TEST[3:0] = 0001, the $\overline{\text{BKPT}}$ function is selected. If TEST[3:0] = 0000, then the TMS function is selected. TEST[3:0] should not change while $\overline{\text{RSTI}} = 1$. When used as TMS, this input signal provides the JTAG controller with information to determine which test operation mode should be performed. The value of TMS and current state of the internal 16-state JTAG controller state machine at the rising edge of TCK determine whether the JTAG controller holds its current state or advances to the next state. This directly controls whether JTAG data or instruction operations occur. TMS has an internal pullup so that if it is not driven low, its value will default to a logic level of 1. However, if TMS will not be used, it should be tied to VDD. This pin also signals a hardware breakpoint to the processor when in the debug mode.

2.20.4 TEST DATA INPUT/DEVELOPMENT SERIAL INPUT

The TDI/DS is a dual-function pin. If TEST[3:0] = 0001, then DSI is selected. If TEST[3:0] = 0000, then TDI is selected. When used as TDI, this input signal provides the serial data port for loading the various JTAG shift registers composed of the boundary scan register, the bypass register, and the instruction register. Shifting in of data depends on the state of the JTAG controller state machine and the instruction currently in the instruction register. This data shift occurs on the rising edge of TCK. TDI also has an internal pullup so that if it is not driven low its value will default to a logic level of 1. However, if TDI will not be used, it should be tied to VDD.

This pin also provides the single-bit communication for the debug module commands.

2.20.5 TEST DATA OUTPUT/DEVELOPMENT SERIAL OUTPUT

The TDO/DSO is a dual-function pin. When TEST[3:0] = 0001, then DSO is selected. When TEST[3:0] = 0000, TDO is selected. When used as TDO, this output signal provides the serial data port for outputting data from the JTAG logic. Shifting out of data depends on the state of the JTAG controller state machine and the instruction currently in the instruction register. This data shift occurs on the falling edge of TCK. When TDO is not outputting test data, it is three-stated. TDO can also be placed in three-state mode to allow bussed or parallel connections to other devices having JTAG. This signal also provides single-bit communication for the debug module responses.

2.21 CLOCK AND RESET SIGNALS

These signals configure the MCF5249 and provide interface signals to the external system.

2.21.1 RESET IN

Asserting $\overline{\text{RSTI}}$ causes the MCF5249 to enter reset exception processing. When $\overline{\text{RSTI}}$ is recognized, the data bus is tri-stated.

2.21.2 SYSTEM BUS INPUT

The CRIN signal is the system clock input. The device has no on-chip clock oscillator, and needs an external oscillator.

Section 3 ColdFire Core

This section provides an overview of the microprocessor core of the MCF5249. The section describes the V2 programming model as it is implemented on the MCF5249. It also includes a full description of exception handling, data formats, an instruction set summary, and a table of instruction timings. For detailed information on instructions, see the *ColdFire Family Programmer's Reference Manual*.

3.1 PROCESSOR PIPELINES

The following figure shows a block diagram of the processor pipelines of a V2 ColdFire core

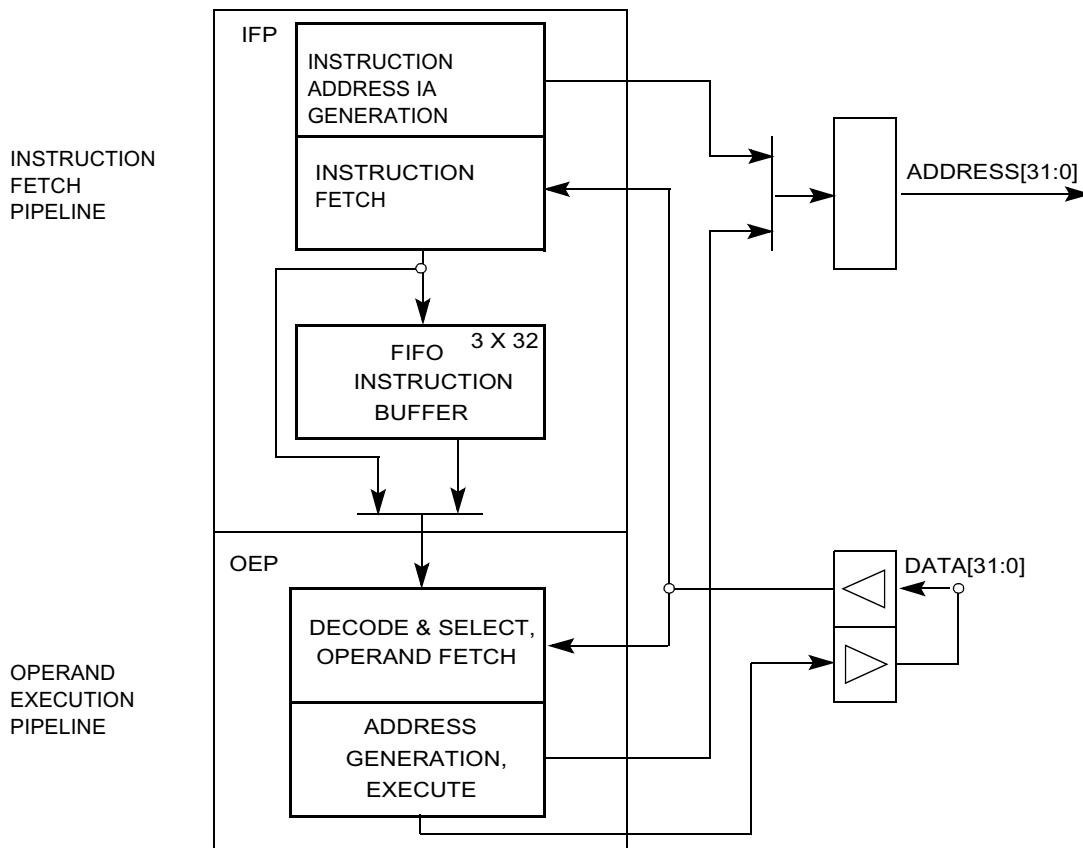

Figure 3-1 V2 ColdFire Processor Core Pipelines

The processor core is comprised of two separate pipelines that are decoupled by an instruction buffer. The Instruction Fetch Pipeline (IFP) is responsible for instruction address generation and instruction fetch. The instruction buffer is a first-in-first-out (FIFO) buffer that holds prefetched instructions awaiting execution in the Operand Execution Pipeline (OEP). The OEP includes two pipeline stages. The first stage decodes instructions and selects operands (DSOC); the second stage (AGEX) performs instruction execution and calculates operand effective addresses, if needed.

3.2 PROCESSOR REGISTER DESCRIPTION

The following sections describe the processor registers in the user and supervisor programming models. The appropriate programming model is selected based on the privilege level (user mode or supervisor mode) of the processor as defined by the S bit of the status register.

3.2.1 USER PROGRAMMING MODEL

Figure 3-2 shows the user programming model. The model is the same as the M68000 family of microprocessors and consists of the following registers:

- 16 general-purpose 32-bit registers (D0–D7, A0–A7)
- 32-bit program counter (PC)
- 8-bit condition code register (CCR)

3.2.1.1 DATA REGISTERS (D0–D7)

Registers D0–D7 are used as data registers for bit (1 bit), byte (8 bit), word (16 bit) and longword (32 bit) operations and can also be used as index registers.

3.2.1.2 ADDRESS REGISTERS (A0–A6)

Registers A0–A6 can be used as software stack pointers, index registers, or base address registers as well as for word and longword operations.

3.2.1.3 STACK POINTER (A7,SP)

The ColdFire architecture supports a single hardware stack pointer (A7) for explicit references as well as for implicit ones during stacking for subroutine calls and returns and exception handling. The initial value of A7 is loaded from the reset exception vector, address \$0. The same register is used for both user and supervisor mode as well as word and longword operations.

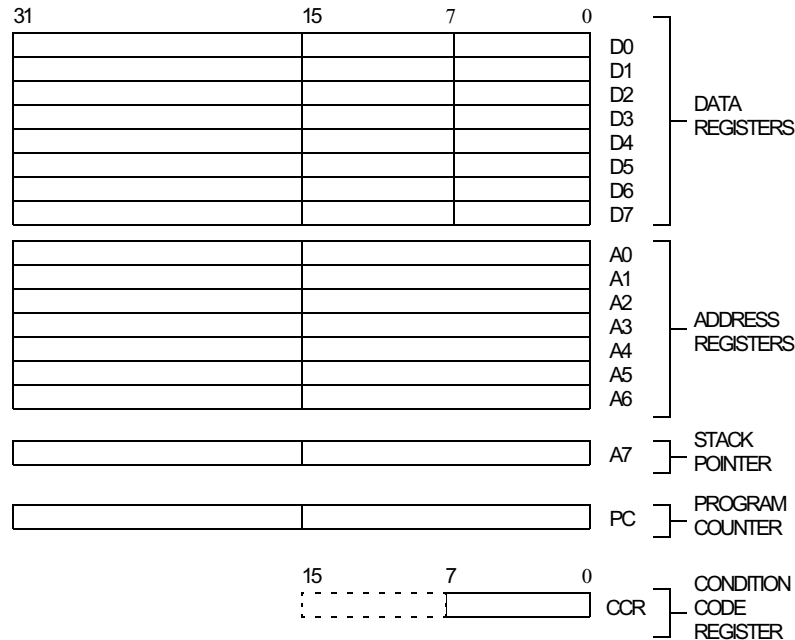

Figure 3-2 User Programming Model

A subroutine call saves the Program Counter (PC) on the stack and the return restores it from the stack. Both the PC and the Status Register (SR) are saved to the stack during the processing of exceptions and interrupts. The return from exception instruction restores the SR and PC values from the stack.

3.2.1.4 PROGRAM COUNTER (PC)

The PC contains the address of the next instruction to execute. During instruction execution and exception processing, the processor automatically increments the contents of the PC or places a new value in the PC, as appropriate. For some addressing modes, the PC can be used as a pointer for PC-relative operand addressing.

3.2.1.5 CONDITION CODE REGISTER (CCR)

The CCR is the least significant byte of the processor status register (SR). Refer to [Section 3.2.3.1 Status Register \(SR\)](#) for more information. Bits 4–0 represent indicator flags based on results generated by processor operations. Bit 4, the extend bit (X bit), is also used as an input operand during multiprecision arithmetic computations.

Table 3-1 Condition Code Register (Bits 0-4)

7	6	5	4	3	2	1	0
—	—	—	X	N	Z	V	C

The following table describes the bits in the condition code register.

Table 3-2 CCR Functionality

BIT	CODE	DESCRIPTION
7-5	—	Reserved, should be cleared.
4	X	Extend condition code bit. Assigned the value of the carry bit for arithmetic operations; otherwise not affected or set to a specified result. Also used as an input operand for multiple-precision arithmetic.
3	N	Negative condition code bit. Set if the msb of the result is set; otherwise cleared.
2	Z	Zero condition code bit. Set if the result equals zero; otherwise cleared.
1	V	Overflow condition code bit. Set if an arithmetic overflow occurs, implying that the result cannot be represented in the operand size; otherwise cleared.
0	C	Carry condition code bit. Set if a carry-out of the data operand msb occurs for an addition or if a borrow occurs in a subtraction; otherwise cleared.

3.2.2 ENHANCED MULTIPLY ACCUMULATE MODULE (EMAC) USER PROGRAMMING MODEL

The EMAC provides a variety of program-visible registers:

- Four 48-bit accumulators (Raccx = Racc0, Racc1, Racc2, Racc3)
- Eight 8-bit accumulator extensions (2 per accumulator), packaged as two 32-bit values for load and store operations (Raccext01, Raccext23)
- One 16-bit Mask Register (Rmask)
- One 32-bit Status Register (MACSR) including four indicator bits signaling product or accumulation overflow (one for each accumulator: PAV0, PAV1, PAV2, PAV3)

3.2.2.1 EMAC INSTRUCTION SET SUMMARY

The EMAC unit supports the integer multiply operations defined by the baseline ColdFire architecture, as well as the multiply-accumulate instructions. The following table summarizes the EMAC unit instruction set.

Table 3-3 EMAC Instruction Summary

COMMAND	MNEMONIC	DESCRIPTION
Multiply Signed	MULS <ea>y,Dx	Multiplies two signed operands yielding a signed result
Multiply Unsigned	MULU <ea>y,Dx	Multiplies two unsigned operands yielding an unsigned result
Multiply Accumulate	MAC Ry,RxSF,Raccx MSAC Ry,RxSF,Raccx	Multiplies two operands, then adds/subtracts the product to/from an accumulator
Multiply Accumulate with Load	MAC Ry,RxSF,Rw,Raccx MSAC Ry,RxSF,Rw,Raccx	Multiplies two operands, then combines the product to an accumulator while loading a register with the memory operand
Load Accumulator	MOV.L {Ry,#imm},Raccx	Loads an accumulator with a 32-bit operand
Store Accumulator	MOV.L Raccx,Rx	Writes the contents of an accumulator to a CPU register
Copy Accumulator	MOV.L Raccy,Raccx	Copies a 48-bit accumulator

Table 3-3 EMAC Instruction Summary (Continued)

COMMAND	MNEMONIC	DESCRIPTION
Load MAC Status Reg	MOV.L {Ry,#imm},MACSR	Writes a value to the MAC status register
Store MAC Status Reg	MOV.L MACSR,Rx	Write the contents of the MAC status register to a CPU register
Store MACSR to CCR	MOV.L MACSR,CCR	Write the contents of the MAC status register to the processor's CCR register
Load MAC Mask Reg	MOV.L {Ry,#imm},Rmask	Writes a value to the MAC Mask Register
Store MAC Mask Reg	MOV.L Rmask,Rx	Writes the contents of the MAC mask register to a CPU register
Load AccExtensions01	MOV.L {Ry,#imm},Raccext01	Loads the accumulator 0,1 extension bytes with a 32-bit operand
Load AccExtensions23	MOV.L {Ry,#imm},Raccext23	Loads the accumulator 2,3 extension bytes with a 32-bit operand
Store AccExtensions01	MOV.L Raccext01,Rx	Writes the contents of accumulator 0,1 extension bytes into a CPU register
Store AccExtensions23	MOV.L Raccext23,Rx	Writes the contents of accumulator 2,3 extension bytes into a CPU register

3.2.3 SUPERVISOR PROGRAMMING MODEL

Only system programmers use the supervisor programming model to implement sensitive operating system functions, I/O control, and memory management. All accesses that affect the control features of ColdFire processors are in the supervisor programming model, which consists of the registers available to users as well as the following control registers:

- 16-bit status register (SR)
- 32-bit vector base register (VBR)

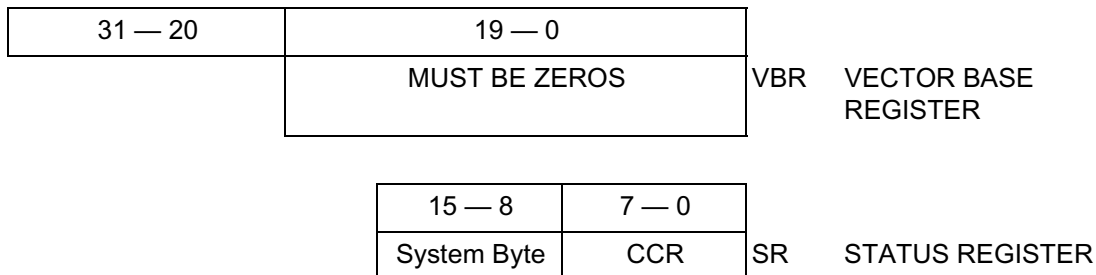

Figure 3-3 Supervisor Programming Model

Additional registers may be supported on a part-by-part basis.

The following sections describe the supervisor programming model registers.

Freescale Semiconductor, Inc.

Processor Register Description

3.2.3.1 STATUS REGISTER (SR)

The SR stores the processor status and includes the CCR, the interrupt priority mask, and other control bits. In the supervisor mode, software can access the entire SR. In user mode, only the lower 8 bits are accessible (CCR). The control bits indicate the following states for the processor: trace mode (T-bit), supervisor or user mode (S bit), and master or interrupt state (M).

Table 3-4 Status Register

SYSTEM BYTE								CONDITION CODE REGISTER (CCR)							
15	14	13	12	11	10	9	8	7	6	5	4	3	2	1	0
T	0	S	M	0	I[2:0]			0	0	0	X	N	Z	V	C

Table 3-5 Status Bit Descriptions

BIT NAME	DESCRIPTION
T	When set, the trace enable allows the processor to perform a trace exception after every instruction.
S	The supervisor / user state bit denotes whether the processor is in supervisor mode (S=1) or user mode (S=0).
M	The master / interrupt state bit is cleared by an interrupt exception, and can be set by software during execution of the RTE or move to SR instructions.
I [2:0]	The interrupt priority mask defines the current interrupt priority. Interrupt requests are inhibited for all priority levels less than or equal to the current priority, except the edge-sensitive level 7 request, which cannot be masked.

3.2.3.2 VECTOR BASE REGISTER (VBR)

The VBR contains the base address of the exception vector table in memory. The displacement of an exception vector is added to the value in this register to access the vector table. The lower 20 bits of the VBR are not implemented by ColdFire processors; they are zero, forcing the table to be aligned on a 1 MByte boundary.

	30 — 21	19 — 0
Field	Exception vector table base address	—
Reset	0000_0000_0000_0000_0000_0000_0000_0000	
R/W	Written from a BDM serial command or from the CPU using the MOVEC instruction. VBR can be read from the debug module only. The upper 12 bits are returned, the low-order 20 bits are undefined.	
Rc [11-0]	0x801	

Figure 3-4 Vector Base Register (VBR)

3.3 EXCEPTION PROCESSING OVERVIEW

Exception processing for ColdFire processors is streamlined for performance. The ColdFire processors provide a simplified exception processing model. The next section details the model. Differences from previous 68000 Family processors include:

- A simplified exception vector table
- Reduced relocation capabilities using the vector base register
- A single exception stack frame format
- Use of a single self-aligning system stack

ColdFire processors use an instruction restart exception model but do require more software support to recover from certain access errors.

Exception processing is comprised of four major steps and is defined as the time from the detection of the fault condition to the fetch of the first handler instruction has been initiated.

1. The processor makes an internal copy of the SR and then enters supervisor mode by setting the S bit and disabling trace mode by clearing the T bit. The occurrence of an interrupt exception also forces the M bit to be cleared and the interrupt priority mask to be set to the level of the current interrupt request.
2. The processor determines the exception vector number. For all faults *except* interrupts, the processor performs this calculation based on the exception type. For interrupts, the processor performs an interrupt-acknowledge (IACK) bus cycle to obtain the vector number from a peripheral device. The IACK cycle is mapped to a special acknowledge address space with the interrupt level encoded in the address.
3. The processor saves the current context by creating an exception stack frame on the system stack. The V2 Core supports a single stack pointer in the A7 address register; therefore, there is no notion of separate supervisor or user stack pointers. As a result, the exception stack frame is created at a 0-modulo-4 address on the top of the current system stack. Additionally, the processor uses a simplified fixed-length stack frame for all exceptions. The exception type determines whether the program counter placed in the exception stack frame defines the location of the faulting instruction (fault) or the address of the next instruction to be executed (next).
4. The processor calculates the address of the first instruction of the exception handler. By definition, the exception vector table is aligned on a 1 Mbyte boundary. This instruction address is generated by fetching an exception vector from the table located at the address defined in the vector base register. The index into the exception table is calculated as $(4 \times \text{vector number})$. Once the exception vector has been fetched, the contents of the vector determine the address of the first instruction of the desired handler. After the instruction fetch for the first opcode of the handler has been initiated, exception processing terminates and normal instruction processing continues in the handler.

ColdFire 5200 processors support a 1024-byte vector table aligned on any 1 Mbyte address boundary (see [Table 3-6](#)). The table contains 256 exception vectors where the first 64 are defined by Motorola and the remaining 192 are user-defined interrupt vectors.

The V2 Core processor inhibits sampling for interrupts during the first instruction of all exception handlers. This allows any handler to effectively disable interrupts, if necessary, by raising the interrupt mask level contained in the status register.

Table 3-6 Exception Vector Assignments

VECTOR NUMBER(S)	VECTOR OFFSET (HEX)	STACKED PROGRAM COUNTER	ASSIGNMENT
0	\$000	—	Initial stack pointer
1	\$004	—	Initial program counter
2	\$008	Fault	Access error
3	\$00C	Fault	Address error
4	\$010	Fault	Illegal instruction
5	\$014	Fault	Divide by zero
6-7	\$018-\$01C	—	Reserved
8	\$020	Fault	Privilege violation
9	\$024	Next	Trace
10	\$028	Fault	Unimplemented line-a opcode
11	\$02C	Fault	Unimplemented line-f opcode
12	\$030	Next	Debug interrupt
13	\$034	—	Reserved
14	\$038	Fault	Format error
15	\$03C	Next	Uninitialized interrupt
16-23	\$040-\$05C	—	Reserved
24	\$060	Next	Spurious interrupt
25-31	\$064-\$07C	Next	Level 1-7 autovectored interrupts
32-47	\$080-\$0BC	Next	Trap # 0-15 instructions
48-63	\$0C0-\$0FC	—	Reserved
64-255	\$100-\$3FC	Next	User-defined interrupts
Note: "Fault" refers to the PC of the instruction that caused the exception			
Note: "Next" refers to the PC of the next instruction that follows the instruction that caused the fault.			

3.4 EXCEPTION STACK FRAME DEFINITION

The exception stack frame is shown in [Figure 3-5](#). The first longword of the exception stack frame contains the 16-bit format/vector word (F/V) and the 16-bit status register, and the second longword contains the 32-bit program counter address.

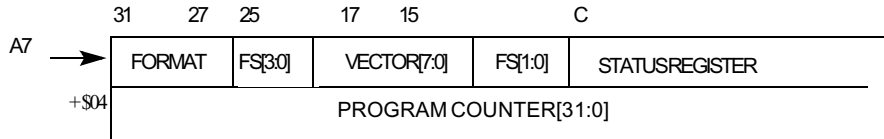

Figure 3-5 Exception Stack Frame Form

The 16-bit format/vector word contains 3 unique fields:

- A 4-bit format field at the top of the system stack is always written with a value of {4,5,6,7} by the processor indicating a two-longword frame format. See [Table 3-7](#).

Table 3-7 Format Field Encoding

ORIGINAL A7 @ TIME OF EXCEPTION, BITS 1:0	A7 @ 1ST INSTRUCTION OF HANDLER	FORMAT FIELD
00	Original A7 - 8	4
01	Original A7 - 9	5
10	Original A7 - 10	6
11	Original A7 - 11	7

- There is a 4-bit fault status field, FS[3:0], at the top of the system stack. This field is defined for access and address errors only and written as zeros for all other types of exceptions. See [Table 3-8](#).

Table 3-8 Fault Status Encoding

FS[3:0]	DEFINITION
00xx	Reserved
0100	Error on instruction fetch
0101	Reserved
011x	Reserved
1000	Error on operand write
1001	Attempted write to write-protected space
101x	Reserved
1100	Error on operand read
1101	Reserved
111x	Reserved

- The 8-bit vector number, vector[7:0], defines the exception type and is calculated by the processor for all internal faults and represents the value supplied by the peripheral in the case of an interrupt. Refer to [Table 3-6](#).

3.5 PROCESSOR EXCEPTIONS

3.5.1 ACCESS ERROR EXCEPTION

The exact processor response to an access error depends on the type of memory reference being performed. For an instruction fetch, the processor postpones the error reporting until the faulted reference is needed by an instruction for execution. Therefore, faults that occur during instruction prefetches that are then followed by a change of instruction flow do not generate an exception. When the processor attempts to execute an instruction with a faulted opword and/or extension words, the access error is signaled and the instruction aborted. For this type of exception, the programming model has not been altered by the instruction generating the access error.

If the access error occurs on an operand read, the processor immediately aborts the current instruction's execution and initiates exception processing. In this situation, any address register updates attributable to the auto-addressing modes, (e.g., (An)+,-(An)), have already been performed, so the programming model contains the updated An value. In addition, if an access error occurs during the execution of a MOVEM instruction loading from memory, any registers already updated *before* the fault occurs contains the operands from memory.

The ColdFire processor uses an imprecise reporting mechanism for access errors on operand writes. Because the actual write cycle may be decoupled from the processor's issuing of the operation, the signaling of an access error appears to be decoupled from the instruction that generated the write. Accordingly, the PC contained in the exception stack frame merely represents the location in the program when the access error was signaled. All programming model updates associated with the write instruction are completed. The NOP instruction can collect access errors for writes. This instruction delays its execution until all previous operations, including all pending write operations, are complete. If any previous write terminates with an access error, it is guaranteed to be reported on the NOP instruction.

3.5.2 ADDRESS ERROR EXCEPTION

Any attempted execution transferring control to an odd instruction address (i.e., if bit 0 of the target address is set) results in an address error exception.

Any attempted use of a word-sized index register (Xn.w) or a scale factor of 8 on an indexed effective addressing mode generates an address error as does an attempted execution of a full-format indexed addressing mode.

3.5.3 ILLEGAL INSTRUCTION EXCEPTION

The MCF5249 processors decode the full 16-bit opcode and generate this exception if execution of an unsupported instruction is attempted. Additionally, attempting to execute an illegal line A or line F opcode generates unique exception types: vectors 10 and 11, respectively.

ColdFire processors do not provide illegal instruction detection on extension words of any instruction, including MOVEC. Attempting to execute an instruction with an illegal extension word causes undefined results.

3.5.4 DIVIDE BY ZERO

Attempted division by zero causes an exception (vector 5, offset = 0x014) except when the PC points to the faulting instruction (DIVU, DIVS, REMU, REMS).

3.5.5 PRIVILEGE VIOLATION

The attempted execution of a supervisor mode instruction while in user mode generates a privilege violation exception. Refer to the *ColdFire Programmer's Reference Manual* for lists of supervisor- and user-mode instructions.

3.5.6 TRACE EXCEPTION

To aid in program development, the V2 processors provide an instruction-by-instruction tracing capability. While in trace mode, indicated by the assertion of the T bit in the status register (SR[15] = 1), the completion of an instruction execution signals a trace exception. This functionality allows a debugger to monitor program execution.

The single exception to this definition is the STOP instruction. When the STOP opcode is executed, the processor core waits until an unmasked interrupt request is asserted, then aborts the pipeline and initiates interrupt exception processing.

Because ColdFire processors do not support hardware stacking of multiple exceptions, it is the responsibility of the operating system to check for trace mode after processing other exception types. For example, consider the execution of a TRAP instruction while in trace mode. The processor will initiate the TRAP exception and then pass control to the corresponding handler. If the system requires that a trace exception be processed, it is the responsibility of the TRAP exception handler to check for this condition (SR[15] in the exception stack frame asserted) and pass control to the trace handler before returning from the original exception.

3.5.7 DEBUG INTERRUPT

This exception is generated in response to a hardware breakpoint register trigger. The processor does not generate an IACK cycle but rather calculates the vector number internally (vector number 12).

3.5.8 RTE AND FORMAT ERROR EXCEPTIONS

When an RTE instruction is executed, the processor first examines the 4-bit format field to validate the frame type. For a ColdFire 5200 processor, any attempted execution of an RTE where the format is not equal to {4,5,6,7} generates a format error. The exception stack frame for the format error is created without disturbing the original RTE frame and the stacked PC pointing to the RTE instruction.

The selection of the format value provides some limited debug support for porting code from 68000 applications. On 680x0 family processors, the SR was located at the top of the stack. On those processors, bit[30] of the longword addressed by the system stack pointer is typically zero. Thus, if an RTE is attempted using this "old" format, it generates a format error on a ColdFire 5200 processor.

If the format field defines a valid type, the processor: (1) reloads the SR operand, (2) fetches the second longword operand, (3) adjusts the stack pointer by adding the format value to the auto-incremented address after the fetch of the first longword, and then (4) transfers control to the instruction address defined by the second longword operand within the stack frame.

3.5.9 TRAP INSTRUCTION EXCEPTIONS

Executing TRAP always forces an exception and is useful for implementing system calls. The trap instruction may be used to change from user to supervisor mode.

3.5.10 INTERRUPT EXCEPTION

The interrupt exception processing, with interrupt recognition and vector fetching, includes uninitialized and spurious interrupts as well as those where the requesting device supplies the 8-bit interrupt vector. Autovectoring may optionally be supported through the System Integration module (SIM).

3.5.11 FAULT-ON-FAULT HALT

If a V2 processor encounters any type of fault during the exception processing of another fault, the processor immediately halts execution with the catastrophic “fault-on-fault” condition. A reset is required to force the processor to exit this halted state.

3.5.12 RESET EXCEPTION

Asserting the reset input signal to the processor causes a reset exception. The reset exception has the highest priority of any exception; it provides for system initialization and recovery from catastrophic failure. Reset also aborts any processing in progress when the reset input is recognized. Processing cannot be recovered.

The reset exception places the processor in the supervisor mode by setting the S bit and disables tracing by clearing the T bit in the SR. This exception also clears the M bit and sets the processor’s interrupt priority mask in the SR to the highest level (level 7). Next, the VBR is initialized to zero (\$00000000). The control registers specifying the operation of any memories (e.g., cache and/or RAM modules) connected directly to the processor are disabled.

Note: Other implementation-specific supervisor registers are also affected.
Refer to each of the modules in this manual for details on these registers.

After reset is negated, the core performs two longword read bus cycles. The first longword at address 0 is loaded into the stack pointer and the second longword at address 4 is loaded into the program counter. After the initial instruction is fetched from memory, program execution begins at the address in the PC. If an access error or address error occurs before the first instruction is executed, the processor enters the fault-on-fault halted state.

3.6 INSTRUCTION EXECUTION TIMING

This section describes V2 processor instruction execution times in terms of processor core clock cycles. The number of operand references for each instruction is enclosed in parentheses following the number of clock cycles. Each timing entry is presented as C(r/w) where:

- C — number of processor clock cycles, including all applicable operand fetches and writes, and all internal core cycles required to complete the instruction execution.
- r/w — number of operand reads (r) and writes (w) required by the instruction. An operation performing a read-modify-write function is denoted as (1/1).

This section includes the assumptions concerning the timing values and the execution time details.

3.6.1 TIMING ASSUMPTIONS

For the timing data presented in this section, the following assumptions apply:

1. The operand execution pipeline (OEP) is loaded with the opword and all required extension words at the beginning of each instruction execution. This implies that the OEP does not wait for the instruction fetch pipeline (IFP) to supply opwords and/or extension words.
2. The OEP does not experience any sequence-related pipeline stalls. For ColdFire 5200 processors, the most common example of this type of stall involves consecutive store operations, excluding the MOVEM instruction. For all STORE operations (except MOVEM), certain hardware resources within the processor are marked as “busy” for two clock cycles after the final DSOC cycle of the store instruction. If a subsequent STORE instruction is encountered within this 2-cycle window, it will be stalled until the resource again becomes available. Thus, the maximum pipeline stall involving consecutive STORE operations is 2 cycles. The MOVEM instruction uses a different set of resources and this stall does not apply.
3. The OEP completes all memory accesses without any stall conditions caused by the memory itself. Thus, the timing details provided in this section assume that an infinite zero-wait state memory is attached to the processor core.
4. All operand data accesses are aligned on the same byte boundary as the operand size, i.e., 16 bit operands aligned on 0-modulo-2 addresses, 32 bit operands aligned on 0-modulo-4 addresses.

If the operand alignment fails these guidelines, it is misaligned. The processor core decomposes the misaligned operand reference into a series of aligned accesses as shown in the following table.

Table 3-9 Misaligned Operand References

ADDRESS[1:0]	SIZE	KBUS OPERATIONS	ADDITIONAL C(R/W)
X1	Word	Byte, Byte	2(1/0) if read 1(0/1) if write
X1	Long	Byte, Word, Byte	3(2/0) if read 2(0/2) if write
10	Long	Word, Word	2(1/0) if read 1(0/1) if write

3.6.2 MOVE INSTRUCTION EXECUTION TIMES

The execution times for the MOVE.{B,W} instructions are shown in [Table 3-10](#), while [Table 3-11](#) provides the timing for MOVE.L.

Note: For all tables in this section, the execution time of any instruction using the PC-relative effective addressing modes is the same for the comparable An-relative mode.

Freescale Semiconductor, Inc.
Instruction Execution Timing

The nomenclature “xxx.wl” refers to both forms of absolute addressing, xxx.w and xxx.l.

Table 3-10 Move Byte and Word Execution times

SOURCE	DESTINATION						
	RX	(AX)	(AX)+	-(AX)	(D ₁₆ ,AX)	(D ₈ ,AX,XI)	(XXX).WL
Dn	1(0/0)	1(0/1)	1(0/1)	1(0/1)	1(0/1)	2(0/1)	1(0/1)
An	1(0/0)	1(0/1)	1(0/1)	1(0/1)	1(0/1)	2(0/1)	1(0/1)
(An)	3(1/0)	3(1/1)	3(1/1)	3(1/1)	3(1/1)	4(1/1)	3(1/1)
(An)+	3(1/0)	3(1/1)	3(1/1)	3(1/1)	3(1/1)	4(1/1)	3(1/1)
-(An)	3(1/0)	3(1/1)	3(1/1)	3(1/1)	3(1/1)	4(1/1)	3(1/1)
(d ₁₆ ,An)	3(1/0)	3(1/1)	3(1/1)	3(1/1)	3(1/1)	—	—
(d ₈ ,An,Xi)	4(1/0)	4(1/1)	4(1/1)	4(1/1)	—	—	—
(xxx).w	3(1/0)	3(1/1)	3(1/1)	3(1/1)	—	—	—
(xxx).l	3(1/0)	3(1/1)	3(1/1)	3(1/1)	—	—	—
(d ₁₆ ,PC)	3(1/0)	3(1/1)	3(1/1)	3(1/1)	3(1/1)	—	—
(d ₈ ,PC,Xi)	4(1/0)	4(1/1)	4(1/1)	4(1/1)	—	—	—
#<xxx>	1(0/0)	3(0/1)	3(0/1)	3(0/1)	—	—	—

Table 3-11 Move Long Execution Times

SOURCE	DESTINATION						
	RX	(AX)	(AX)+	-(AX)	(D ₁₆ ,AX)	(D ₈ ,AX,XI)	(XXX).WL
Dn	1(0/0)	1(0/1)	1(0/1)	1(0/1)	1(0/1)	2(0/1)	1(0/1)
An	1(0/0)	1(0/1)	1(0/1)	1(0/1)	1(0/1)	2(0/1)	1(0/1)
(An)	2(1/0)	2(1/1)	2(1/1)	2(1/1)	2(1/1)	3(1/1)	2(1/1)
(An)+	2(1/0)	2(1/1)	2(1/1)	2(1/1)	2(1/1)	3(1/1)	2(1/1)
-(An)	2(1/0)	2(1/1)	2(1/1)	2(1/1)	2(1/1)	3(1/1)	2(1/1)
(d ₁₆ ,An)	2(1/0)	2(1/1)	2(1/1)	2(1/1)	2(1/1)	—	—
(d ₈ ,An,Xi)	3(1/0)	3(1/1)	3(1/1)	3(1/1)	—	—	—
(xxx).w	2(1/0)	2(1/1)	2(1/1)	2(1/1)	—	—	—
(xxx).l	2(1/0)	2(1/1)	2(1/1)	2(1/1)	—	—	—
(d ₁₆ ,PC)	2(1/0)	2(1/1)	2(1/1)	2(1/1)	2(1/1)	—	—
(d ₈ ,PC,Xi)	3(1/0)	3(1/1)	3(1/1)	3(1/1)	—	—	—
#<xxx>	1(0/0)	2(0/1)	2(0/1)	2(0/1)	—	—	—

3.7 STANDARD ONE OPERAND INSTRUCTION EXECUTION TIMES

Table 3-12 One Operand Instruction Execution Times

OPCODE	<EA>	EFFECTIVE ADDRESS							
		RN	(AN)	(AN)+	-(AN)	(D16,AN)	(D8,AN,XN*SF)	XXX.WL	#XXX
clr.b	<ea>	1(0/0)	1(0/1)	1(0/1)	1(0/1)	1(0/1)	2(0/1)	1(0/1)	—
clr.w	<ea>	1(0/0)	1(0/1)	1(0/1)	1(0/1)	1(0/1)	2(0/1)	1(0/1)	—
clr.l	<ea>	1(0/0)	1(0/1)	1(0/1)	1(0/1)	1(0/1)	2(0/1)	1(0/1)	—
ext.w	Dx	1(0/0)	—	—	—	—	—	—	—
ext.l	Dx	1(0/0)	—	—	—	—	—	—	—
extb.l	Dx	1(0/0)	—	—	—	—	—	—	—
neg.l	Dx	1(0/0)	—	—	—	—	—	—	—
negx.l	Dx	1(0/0)	—	—	—	—	—	—	—
not.l	Dx	1(0/0)	—	—	—	—	—	—	—
Scc	Dx	1(0/0)	—	—	—	—	—	—	—
swap	Dx	1(0/0)	—	—	—	—	—	—	—
tst.b	<ea>	1(0/0)	3(1/0)	3(1/0)	3(1/0)	3(1/0)	4(1/0)	3(1/0)	1(0/0)
tst.w	<ea>	1(0/0)	3(1/0)	3(1/0)	3(1/0)	3(1/0)	4(1/0)	3(1/0)	1(0/0)
tst.l	<ea>	1(0/0)	2(1/0)	2(1/0)	2(1/0)	2(1/0)	3(1/0)	2(1/0)	1(0/0)

3.8 STANDARD TWO OPERAND INSTRUCTION EXECUTION TIMES

Table 3-13 Two Operand Instruction Execution Times - (MACS)

OPCODE	<EA>	EFFECTIVE ADDRESS							
		RN	(AN)	(AN)+	-(AN)	(D16,AN) (D16,PC)	(D8,AN,XN*SF) (D8,PC,XN*SF)	XXX.WL	#XXX
add.l	<ea>,Rx	1(0/0)	3(1/0)	3(1/0)	3(1/0)	3(1/0)	4(1/0)	3(1/0)	1(0/0)
add.l	Dy,<ea>	—	3(1/1)	3(1/1)	3(1/1)	3(1/1)	4(1/1)	3(1/1)	—
addi.l	#imm,Dx	1(0/0)	—	—	—	—	—	—	—
addq.l	#imm,<ea>	1(0/0)	3(1/1)	3(1/1)	3(1/1)	3(1/1)	4(1/1)	3(1/1)	—
addx.l	Dy,Dx	1(0/0)	—	—	—	—	—	—	—
and.l	<ea>,Rx	1(0/0)	3(1/0)	3(1/0)	3(1/0)	3(1/0)	4(1/0)	3(1/0)	1(0/0)
and.l	Dy,<ea>	—	3(1/1)	3(1/1)	3(1/1)	3(1/1)	4(1/1)	3(1/1)	—
andi.l	#imm,Dx	1(0/0)	—	—	—	—	—	—	—
asl.l	<ea>,Dx	1(0/0)	—	—	—	—	—	—	1(0/0)
asr.l	<ea>,Dx	1(0/0)	—	—	—	—	—	—	1(0/0)
bchg	Dy,<ea>	2(0/0)	4(1/1)	4(1/1)	4(1/1)	4(1/1)	5(1/1)	4(1/1)	—
bchg	#imm,<ea>	2(0/0)	4(1/1)	4(1/1)	4(1/1)	4(1/1)	—	—	—
bclr	Dy,<ea>	2(0/0)	4(1/1)	4(1/1)	4(1/1)	4(1/1)	5(1/1)	4(1/1)	—
bclr	#imm,<ea>	2(0/0)	4(1/1)	4(1/1)	4(1/1)	4(1/1)	—	—	—
bset	Dy,<ea>	2(0/0)	4(1/1)	4(1/1)	4(1/1)	4(1/1)	5(1/1)	4(1/1)	—
bset	#imm,<ea>	2(0/0)	4(1/1)	4(1/1)	4(1/1)	4(1/1)	—	—	—
btst	Dy,<ea>	2(0/0)	3(1/1)	3(1/1)	3(1/1)	3(1/1)	4(1/1)	3(1/1)	—
btst	#imm,<ea>	1(0/0)	3(1/1)	3(1/1)	3(1/1)	3(1/1)	—	—	1(0/0)
cmp.l	<ea>,Rx	1(0/0)	3(1/0)	3(1/0)	3(1/0)	3(1/0)	4(1/0)	3(1/0)	1(0/0)
cmpi.l	#imm,Dx	1(0/0)	—	—	—	—	—	—	—
DIVS.W	<ea>,Dx	20(0/0)	23(1/0)	23(1/0)	23(1/0)	23(1/0)	24(1/0)	23(1/0)	20(0/0)
DIVU.W	<ea>,Dx	20(0/0)	23(1/0)	23(1/0)	23(1/0)	23(1/0)	24(1/0)	23(1/0)	20(0/0)
DIVS.L	<ea>,Dx	35(0/0)	38(1/0)	38(1/0)	38(1/0)	38(1/0)			
DIVU.L	<ea>,Dx	35(0/0)	38(1/0)	38(1/0)	38(1/0)	38(1/0)			
eor.l	Dy,<ea>	1(0/0)	3(1/1)	3(1/1)	3(1/1)	3(1/1)	4(1/1)	3(1/1)	—
eori.l	#imm,Dx	1(0/0)	—	—	—	—	—	—	—
lea	<ea>,Ax	—	1(0/0)	—	—	1(0/0)	2(0/0)	1(0/0)	—
lsl.l	<ea>,Dx	1(0/0)	—	—	—	—	—	—	1(0/0)
LSR.L	<ea>,Dx	1(0/0)	—	—	—	—	—	—	1(0/0)
MAC.W	Ry,Rx	1(0/0)	—	—	—	—	—	—	—
MAC.L	Ry,Rx	1(0/0)	—	—	—	—	—	—	—
MSAC.W	Ry,Rx	1(0/0)	—	—	—	—	—	—	—

Table 3-13 Two Operand Instruction Execution Times - (MACS) (Continued)

OPCODE	<EA>	EFFECTIVE ADDRESS							
		RN	(AN)	(AN)+	-(AN)	(D16,AN) (D16,PC)	(D8,AN,XN*SF) (D8,PC,XN*SF)	XXX.WL	#XXX
MSAC.L	Ry,Rx	3(0/0)	—	—	—	—	—	—	—
MAC.W	Ry,Rx,ea,Rw	—	2(1/0)	2(1/0)	2(1/0)	2(1/0)	—	—	—
MAC.L	Ry,Rx,ea,Rw	—	2(1/0)	2(1/0)	2(1/0)	2(1/0)	—	—	—
MSAC.W	Ry,Rx,ea,Rw	—	2(1/0)	2(1/0)	2(1/0)	2(1/0)	—	—	—
MSAC.L	Ry,Rx,ea,Rw	—	2(1/0)	2(1/0)	2(1/0)	2(1/0)	—	—	—
MOVEQ	#imm,Dx	—	—	—	—	—	—	—	1(0/0)
MULS.W	<ea>,Dx	4(0/0)	6(1/0)	6(1/0)	6(1/0)	6(1/0)	12(1/0)	11(1/0)	9(0/0)
mulu.w	<ea>,Dx	4(0/0)	6(1/0)	6(1/0)	6(1/0)	6(1/0)	12(1/0)	11(1/0)	9(0/0)
mul.s.l ¹	<ea>,Dx	≤ 4(0/0)	≤ 6(1/0)	≤ 6(1/0)	≤ 6(1/0)	≤ 6(1/0)	—	—	—
mulu.l ¹	<ea>,Dx	≤ 4(0/0)	≤ 6(1/0)	≤ 6(1/0)	≤ 6(1/0)	≤ 6(1/0)	—	—	—
or.l	<ea>,Rx	1(0/0)	3(1/0)	3(1/0)	3(1/0)	3(1/0)	4(1/0)	3(1/0)	1(0/0)
or.l	Dy,<ea>	—	3(1/1)	3(1/1)	3(1/1)	3(1/1)	4(1/1)	3(1/1)	—
ori.l	#imm,Dx	1(0/0)	—	—	—	—	—	—	—
sub.l	<ea>,Rx	1(0/0)	3(1/0)	3(1/0)	3(1/0)	3(1/0)	4(1/0)	3(1/0)	1(0/0)
rems.l	<ea>,Dx	35(0/0)	38(1/0)	38(1/0)	38(1/0)	38(1/0)	—	—	—
remu.l	<ea>,Dx	35(0/0)	35(1/0)	38(1/0)	38(1/0)	38(1/0)	—	—	—
sub.l	Dy,<ea>	—	3(1/1)	3(1/1)	3(1/1)	3(1/1)	4(1/1)	3(1/1)	—
subi.l	#imm,Dx	1(0/0)	—	—	—	—	—	—	—
subq.l	#imm,<ea>	1(0/0)	3(1/1)	3(1/1)	3(1/1)	3(1/1)	4(1/1)	3(1/1)	—
subx.l	Dy,Dx	1(0/0)	—	—	—	—	—	—	—

3.9 MISCELLANEOUS INSTRUCTION EXECUTION TIMES

Table 3-14 Miscellaneous Instruction Execution Times

OPCODE	<EA>	EFFECTIVE ADDRESS							
		RN	(AN)	(AN)+	-(AN)	(D16,AN)	(D8,AN,Xn*SF)	XXX.WL	#XXX
cpushl	(Ax)	—	11(0/1)	—	—	—	—	—	—
link.w	Ay,#imm	2(0/1)	—	—	—	—	—	—	—
move.w	CCR,Dx	1(0/0)	—	—	—	—	—	—	—
move.w	<ea>,CCR	1(0/0)	—	—	—	—	—	—	1(0/0)
move.w	SR,Dx	1(0/0)	—	—	—	—	—	—	—
move.w	<ea>,SR	7(0/0)	—	—	—	—	—	—	7(0/0) ²
movec	Ry,Rc	9(0/1)	—	—	—	—	—	—	—
movem.l	<ea>,&list	—	1+n(n/0)	—	—	1+n(n/0)	—	—	—
movem.l	&list,<ea>	—	1+n(0/n)	—	—	1+n(0/n)	—	—	—
nop		3(0/0)	—	—	—	—	—	—	—
pea	<ea>	—	2(0/1)	—	—	2(0/1) ⁴	3(0/1) ⁵	2(0/1)	—
pulse		1(0/0)	—	—	—	—	—	—	—
stop	#imm	—	—	—	—	—	—	—	3(0/0) ³
trap	#imm	—	—	—	—	—	—	—	15(1/2)
trapf		1(0/0)	—	—	—	—	—	—	—
trapf.w		1(0/0)	—	—	—	—	—	—	—
trapf.l		1(0/0)	—	—	—	—	—	—	—
unlk	Ax	2(1/0)	—	—	—	—	—	—	—
wddata	<ea>	—	3(1/0)	3(1/0)	3(1/0)	3(1/0)	4(1/0)	3(1/0)	3(1/0)
wdebug	<ea>	—	5(2/0)	—	—	5(2/0)	—	—	—

Note: n is the number of registers moved by the MOVEM opcode.
 Note: ¹≤ indicates that long multiplies have early termination after 9 cycles; thus, actual cycle count is operand independent
 Note: ²If a MOVE.W #imm,SR instruction is executed and imm[13] = 1, the execution time is 1(0/0).
 Note: ³The execution time for STOP is the time required until the processor begins sampling continuously for interrupts.
 Note: ⁴PEA execution times are the same for (d16,PC)
 Note: ⁵PEA execution times are the same for (d8,PC,Xn*SF)

3.10 BRANCH INSTRUCTION EXECUTION TIMES

Table 3-15 General Branch Instruction Execution Times

OPCODE	<EA>	EFFECTIVE ADDRESS							
		RN	(AN)	(AN)+	-(AN)	(D16,AN) (D16,PC)	(D8,AN,XI*SF) (D8,PC,XI*SF)	XXX.WL	#XXX
BSR		—	—	—	—	3(0/1)	—	—	—
JMP	<ea>	—	3(0/0)	—	—	3(0/0)	4(0/0)	3(0/0)	—
JSR	<ea>	—	3(0/1)	—	—	3(0/1)	4(0/1)	3(0/1)	—
RTE		—	—	10(2/0)	—	—	—	—	—
RTS		—	—	5(1/0)	—	—	—	—	—

Table 3-16 BRA, Bcc Instruction Execution Times

OPCODE	FORWARD TAKEN	FORWARD NOT TAKEN	BACKWARD TAKEN	BACKWARD NOT TAKEN
BRA	2(0/0)	—	2(0/0)	—
Bcc	3(0/0)	1(0/0)	2(0/0)	3(0/0)

NOTES

Section 4

Phase-Locked Loop and Clock Dividers

4.1 PLL FEATURES

- The PLL locks to the crystal clock frequency at the CRIN pin and produces a processor clock (PSTCLK) and a bus clock which is always 1/2 of the processor clock.
- The audio clock (AUDIOCLK) is derived directly from the crystal. The DAC clocks MCLK1 and MCLK2 are divided directly from the crystal.
- The PLL is configured by writing to a configuration register. By programming this register, the user may change the processor clock (PSTCLK) and the audio clock (AUDIOCLK).
- The PLL Configuration Register must always be programmed to Bypass mode before it is reprogrammed to change any clock frequency. In bypass mode, the crystal clock is fed to the processor (PSTCLK).
- When the clock circuit is switched from “bypass” to “normal operation”, the switch-over is delayed until the PLL is locked.

The following figure shows the PLL module and the frequency relationships of various clock signals.

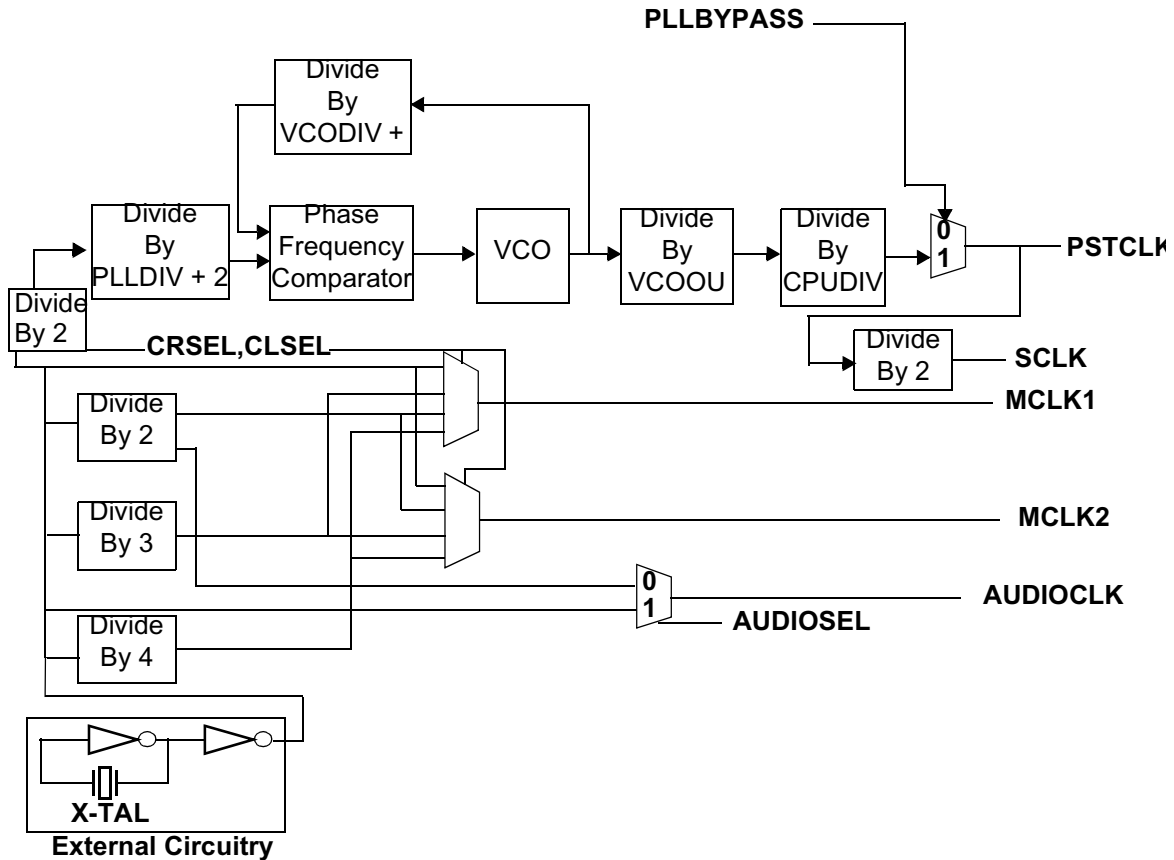

Figure 4-1 Phase-Locked Loop Module Block Diagram

4.2 PLL PROGRAMMING

The different settings for the PLL/clock module are summarized in [Table 4-1](#).

Table 4-1 PLLCR Register

BITS	31	30	29	28	27	26	25	24	23	22	21	20	19	18	17	16
FIELD	LOCK	CLSEL			N/A	CPUDIV			CRSEL	AUDIO SEL	DEBUG SEL	VCODIV				
RESET	0	0	0	0	0	0	0	0	0	0	0	0	0	0	0	0
R/W	R	R/W														
BITS	15	14	13	12	11	10	9	8	7	6	5	4	3	2	1	0
FIELD	VCODIV				QSPI SEL	RST SEL	PLL POWER DOWN	PLLDIV					VCOOUT	N/A	PLL BYPASS	
RESET	0	0	0	0	0	0	0	0	0	0	0	0	0	0	0	0
R/W	R/W															
ADDR	ADDRESS MBAR2BAS + 0 x 180															

Note: Bits marked N/A are reserved bits; program these bits to 0.

Table 4-2 PLLCR Bit Descriptions

BIT NAME	DESCRIPTION
LOCK	Read-only bit, 1 if PLL is locked. (See Note 2 following these bit descriptions.)
CLSEL	(See Note 12) MCLK1, MCLK2 select bit.
CPUDIV	(See Notes 8 and 9) CPU clock divider
CRSEL	(See Note 3) 0 = Fin = Fxtal 1 = Fin = Fxtal/2
AUDIOSEL	(See Note 4) 1 = FXTAL 0 = FXTAL/2
DEBUGSEL	(See Note 11) 1 = Secondary functions on aux debug port. 0 = Aux debug port active.
VCODIV	(See Notes 5 and 10) PLL compare frequency is VCO frequency divided by (VCODIV + 2)
QSPISEL	(See Note 7) 1 = QSPI functions active on pins. (qspi_clk, qspi_din) 0 = IIC functions active on pins. (scl, sda)
VCOOUT	(See Note 6) VCO output divider
PLLBYPASS	(See Notes 1 and 2 following these bit descriptions) 1 = switch to PLL after PLL is locked 0 = Bypass PLL and dividers
RSTSEL	(See Note 7) 1 = SDATA2BS2 function active on pin 0 = RST function active on pin

Table 4-2 PLLCR Bit Descriptions (Continued)

BIT NAME	DESCRIPTION																																																																						
PLLDIV	(See Note 5) Input frequency (Fin) is divided by (PLLDIV + 2) to determine the PLL compare frequency.																																																																						
Note:	1. If this bit is written 0, the PLL is not used, and the crystal clock is sent directly to the CPU. Write this bit 0 before changing any other bit in this register. Write back to 1 after writing new settings. After writing 1 to this bit, new setting will become active after a hardware controlled delay. This delay is ca. 0.5 mS. Clock frequencies described in other notes are only valid when this bit is set 1.																																																																						
Note:	2. PLL may require up to 10.0 mS to lock																																																																						
Note:	3. Fin is input frequency to PLL. Nominal setting for CRSEL is '1' for 33.8688 Mhz X-tal, '0' for 16.9344 Mhz X-tal.																																																																						
Note:	4. AUDIOCLK is clock for audio interfaces. May be 11.2896MHz, 16.9344 or 33.8688 Mhz.																																																																						
Note:	5. $F_{vco} = F_{in} * (V_{CODIV} + 2) / (PLLDIV + 2)$																																																																						
Note:	6. FVCOOUT depends on Fvco (note 5) and VCOOUT setting as shown in the following table:																																																																						
<table border="1"> <thead> <tr> <th>VCO OUT SETTING</th> <th>FVCO OUT</th> </tr> </thead> <tbody> <tr> <td>0</td> <td>Fvco</td> </tr> <tr> <td>1</td> <td>Fvco/2</td> </tr> <tr> <td>2</td> <td>Fvco/2</td> </tr> <tr> <td>3</td> <td>Fvco/4</td> </tr> </tbody> </table>		VCO OUT SETTING	FVCO OUT	0	Fvco	1	Fvco/2	2	Fvco/2	3	Fvco/4																																																												
VCO OUT SETTING	FVCO OUT																																																																						
0	Fvco																																																																						
1	Fvco/2																																																																						
2	Fvco/2																																																																						
3	Fvco/4																																																																						
Note:	7. This bit selects between two different functions implemented on an external pin.																																																																						
Note:	8. $F_{cpu} = FVCOOUT / CPUDIV$; Fcpu is the frequency the processor is running at.																																																																						
Note:	9. If field is "000", divide by 8																																																																						
Note:	10. Fvco max. is 400 Mhz																																																																						
Note:	11. This bit selects the function of the aux_dsi/intmon1, aux_bkpt_b/TA, aux_dsclk/intmon2, and aux-dso/A27 pins. If this bit = 0, the primary function (aux_dsi,aux_bkpt_b,aux_dsclk, and aux_dso) is selected. If this bit = 1, the secondary function (intmon1, TA,intmon2, and A27) is selected.																																																																						
Note:	12. This field determines the frequency of the DAC clocks. Fxtal/3 and Fxtal/4 should not be used normally:																																																																						
<table border="1"> <thead> <tr> <th>CRSEL</th> <th>CLSEL</th> <th>FREQUENCY MCLK2</th> <th>FREQUENCY MCLK1</th> </tr> </thead> <tbody> <tr><td>1</td><td>000</td><td>FXTAL</td><td>FXTAL/2</td></tr> <tr><td>1</td><td>001</td><td>FXTAL</td><td>FXTAL</td></tr> <tr><td>1</td><td>010</td><td>FXTAL/2</td><td>FXTAL/2</td></tr> <tr><td>1</td><td>011</td><td>FXTAL/2</td><td>FXTAL</td></tr> <tr><td>1</td><td>100</td><td>FXTAL</td><td>FXTAL/2</td></tr> <tr><td>1</td><td>101</td><td>FXTAL</td><td>FXTAL</td></tr> <tr><td>1</td><td>110</td><td>FXTAL/2</td><td>FXTAL/2</td></tr> <tr><td>1</td><td>111</td><td>FXTAL/2</td><td>FXTAL</td></tr> <tr><td>0</td><td>000</td><td>FXTAL/2</td><td>FXTAL/2</td></tr> <tr><td>0</td><td>001</td><td>FXTAL/2</td><td>FXTAL/3</td></tr> <tr><td>0</td><td>010</td><td>FXTAL/2</td><td>FXTAL/4</td></tr> <tr><td>0</td><td>011</td><td>FXTAL/3</td><td>FXTAL/2</td></tr> <tr><td>0</td><td>100</td><td>FXTAL/3</td><td>FXTAL/3</td></tr> <tr><td>0</td><td>101</td><td>FXTAL/3</td><td>FXTAL/4</td></tr> <tr><td>0</td><td>110</td><td>FXTAL/4</td><td>FXTAL/2</td></tr> <tr><td>0</td><td>111</td><td>FXTAL/4</td><td>FXTAL/3</td></tr> </tbody> </table>				CRSEL	CLSEL	FREQUENCY MCLK2	FREQUENCY MCLK1	1	000	FXTAL	FXTAL/2	1	001	FXTAL	FXTAL	1	010	FXTAL/2	FXTAL/2	1	011	FXTAL/2	FXTAL	1	100	FXTAL	FXTAL/2	1	101	FXTAL	FXTAL	1	110	FXTAL/2	FXTAL/2	1	111	FXTAL/2	FXTAL	0	000	FXTAL/2	FXTAL/2	0	001	FXTAL/2	FXTAL/3	0	010	FXTAL/2	FXTAL/4	0	011	FXTAL/3	FXTAL/2	0	100	FXTAL/3	FXTAL/3	0	101	FXTAL/3	FXTAL/4	0	110	FXTAL/4	FXTAL/2	0	111	FXTAL/4	FXTAL/3
CRSEL	CLSEL	FREQUENCY MCLK2	FREQUENCY MCLK1																																																																				
1	000	FXTAL	FXTAL/2																																																																				
1	001	FXTAL	FXTAL																																																																				
1	010	FXTAL/2	FXTAL/2																																																																				
1	011	FXTAL/2	FXTAL																																																																				
1	100	FXTAL	FXTAL/2																																																																				
1	101	FXTAL	FXTAL																																																																				
1	110	FXTAL/2	FXTAL/2																																																																				
1	111	FXTAL/2	FXTAL																																																																				
0	000	FXTAL/2	FXTAL/2																																																																				
0	001	FXTAL/2	FXTAL/3																																																																				
0	010	FXTAL/2	FXTAL/4																																																																				
0	011	FXTAL/3	FXTAL/2																																																																				
0	100	FXTAL/3	FXTAL/3																																																																				
0	101	FXTAL/3	FXTAL/4																																																																				
0	110	FXTAL/4	FXTAL/2																																																																				
0	111	FXTAL/4	FXTAL/3																																																																				

4.2.1 PLL OPERATION

The input to the PLL is either the crystal clock, or the crystal clock divided by two. Selection is done by CRSEL. The PLL divides this input frequency by a programmable division factor ($PLLDIV+2$). In the PLL phase/frequency detector, this divided clock is compared with the VCO output clock divided by ($VCODIV+2$). As a result, $F_{vco} = F_{in} * (VCODIV+2)/(PLLDIV+2)$.

Note: The PLL lock counter is designed for worst case input frequency (F_{in}) of 33.8688MHz. This will result in the required 0.5 ns for the PLL to lock. Other F_{in} frequencies can be used, however, the resulting lock time will be slightly longer.

In a second step, this VCO clock is divided by ($VCOOUT * CPUDIV$) to create the CPU clock $PSTCLK$.

The PLL has a PLL-bypass feature. When PLL bypass is written 0, the crystal clock is passed directly to the CPU. When PLL bypass is written 1, CPU clock will be switched to PLL-generated values. The switching is delayed until the PLL has been locked, and produces a stable clock output for CPU. The processor can read the PLL lock status (bit 31 of PLLCR). The multiplexers that switch between PLL clock and crystal clock is glitch-free, so no system reset is needed after switching this mux.

Note: It is important that before reprogramming the PLL division factors, users must switch to PLL bypass mode. After reprogramming, users may immediately switch back to PLL enabled mode. Switching back is delayed internally until the PLL is locked.

4.2.2 PLL LOCK-IN TIME

PLL lock-in time is less than 10.0 ms.

4.2.3 PLL ELECTRICAL LIMITS

Due to implementation of the block, some limits apply to the PLL block. These limitations are shown in [Table 4-3](#).

Table 4-3 PLL Electrical Limits

NAME	MIN. FREQUENCY MHZ	MAX FREQUENCY MHZ	REASON
Fvco	200	400	PLL limitations
Fcpu	0	120 (144QFP) 140 (160 MAPBGA)	Max. operating frequency of device
Fin	5	50	PLL limitations

4.3 AUDIO CLOCK GENERATION

The audio clocks and output DAC clocks are divided directly from the crystal. Clock settings depend on CRSEL, CLSEL, and AUDIOSEL bits, as explained in Table 4-4. As the table shows, the AUDIOCLK is completely derived from the AUDIOSEL bit, and this clock is independent of the other select bits. For the DAC clocks (MCLK2 and MCLK1) the relationship between CRSEL and CLSEL is defined in Table 4-4.

Table 4-4 PLLCR Bit Fields

PLLCR CLSEL (BITS30-28)	PLLCR CRSEL (BIT 23)	PLLCR CONFIG AUDIOSEL (BIT 22)	AUDIOCLK	MCLK2	MCLK1
000	1	1	FXTAL	FXTAL	FXTAL/2
001	1	1	FXTAL	FXTAL	FXTAL
010	1	1	FXTAL	FXTAL/2	FXTAL/2
011	1	1	FXTAL	FXTAL/2	FXTAL
100	1	1	FXTAL	FXTAL	FXTAL/2
101	1	1	FXTAL	FXTAL	FXTAL
110	1	1	FXTAL	FXTAL/2	FXTAL/2
111	1	1	FXTAL	FXTAL/2	FXTAL
000	1	0	FXTAL/2	FXTAL	FXTAL/2
001	1	0	FXTAL/2	FXTAL	FXTAL
010	1	0	FXTAL/2	FXTAL/2	FXTAL/2
011	1	0	FXTAL/2	FXTAL/2	FXTAL
100	1	0	FXTAL/2	FXTAL	FXTAL/2
101	1	0	FXTAL/2	FXTAL	FXTAL
110	1	0	FXTAL/2	FXTAL/2	FXTAL/2
111	1	0	FXTAL/2	FXTAL/2	FXTAL

Note: MCLK1 and MCLK2 will output a clock signal just after reset and before they can be configured as GPIO if so desired. The frequency of the clock will be the same as CRIN prior to initialization of the PLL.

The multiplexer that switches AUDIOCLK between Fxtal and Fxtal/2 is glitch free. No reset is needed after switching audio clock. For the MCLK1 and MCLK2 clocks, the divide by 2 is 50% duty cycle, divide by 3 is 33% duty cycle, and divide by 4 is 25% duty cycle.

4.4 REDUCED POWER MODE

To save power, it is recommended that users reduce the frequency of the CPU clocks. This is done by reprogramming the PLLCR register.

The PLL is also configured with a power down bit. This bit, when set to '1', allows the PLL to enter "sleep" mode. In "sleep" mode, the VCO and charge pump are turned off.

Note: The PLL must go through the re-locking procedure when it is re-enabled.

4.5 RECOMMENDED SETTINGS

Many valid PLL settings exist. However, in many cases some limitations apply so that only a few typical settings will be used. In a typical system, the following limitations may exist:

- Users want to run the processor at 120, 96, 64, 84, or 72 Mhz clock frequency
- MCLK2 must be one of the following: 16.9344, 11.2896, or 8.4672 Mhz see [Table 4-4](#) in this section for further definition.
- MCLK1 must be one of the following: 16.9344, 11.2896, or 8.4672 Mhz see [Table 4-4](#) in this section for further definition.

As a result of these limitations, users may select a 33.8688 Mhz X-TAL and use the settings shown in [Table 4-5](#).

A utility that calculates PLL frequencies from PLL register settings is available at the following URL:

http://e-www.motorola.com/webapp/sps/library/prod_lib.jsp
 (Select 32-Bit Embedded Processors, 68K/ColdFire, ColdFire MC5XXX, MCF5249).

Table 4-5 Recommended PLL Settings

X-TAL FREQ MHZ	CPU DIV	CRSEL	VCO DIV	PLL DIV	VCO OUT	CPU CLOCK MHZ
33.8688	4	1	0x1AD	0x11	0	96
33.8688	6	1	0x1AD	0x011	0	64
33.8688	4	1	0x100	0x0B	0	84

Section 5

Instruction Cache

5.1 INSTRUCTION CACHE FEATURES

- 8KByte Direct-Mapped Cache
- Single-Cycle Access on Cache Hits
- Physically Located on the ColdFire® Core High-Speed Local Bus
- Nonblocking Design to Maximize Performance
- 16 Byte Line-Fill Buffer
- Configurable Cache Miss-Fetch Algorithm

5.2 INSTRUCTION CACHE PHYSICAL ORGANIZATION

The instruction cache is a direct-mapped single-cycle memory, organized as 512 lines, each containing 16 Bytes. The memory storage consists of a 512-entry tag array (containing addresses and a valid bit), and the data array containing 8KBytes of instruction data, organized as 2048 x 32 bits.

The two memory arrays are accessed in parallel: bits [12:4] of the instruction fetch address provide the index into the tag array, and bits [12:2] addressing the data array. The tag array outputs the address mapped to the given cache location along with the valid bit for the line. This address field is compared to bits [31:12] of the instruction fetch address from the local bus to determine if a cache hit in the memory array has occurred. If the desired address is mapped into the cache memory, the output of the data array is driven onto the ColdFire core's local data bus completing the access in a single cycle.

The tag array maintains a single valid bit per line entry. Accordingly, only entire 16 Byte lines are loaded into the instruction cache.

The instruction cache also contains a 16 Byte fill buffer that provides temporary storage for the last line fetched in response to a cache miss. With each instruction fetch, the contents of the line fill buffer are examined. Thus, each instruction fetch address examines both the tag memory array and the line fill buffer to see if the desired address is mapped into either hardware resource. A cache hit in either the memory array or the line-fill buffer is serviced in a single cycle. Because the line fill buffer maintains valid bits on a longword basis, hits in the buffer can be serviced immediately without waiting for the entire line to be fetched.

If the referenced address is not contained in the memory array or the line-fill buffer, the instruction cache initiates the required external fetch operation. In most situations, this is a 16-byte line-sized burst reference.

The hardware implementation is a nonblocking design, meaning the ColdFire core's local bus is released after the initial access of a miss. Thus, the cache or the SRAM module can service subsequent requests while the remainder of the line is being fetched and loaded into the fill buffer.

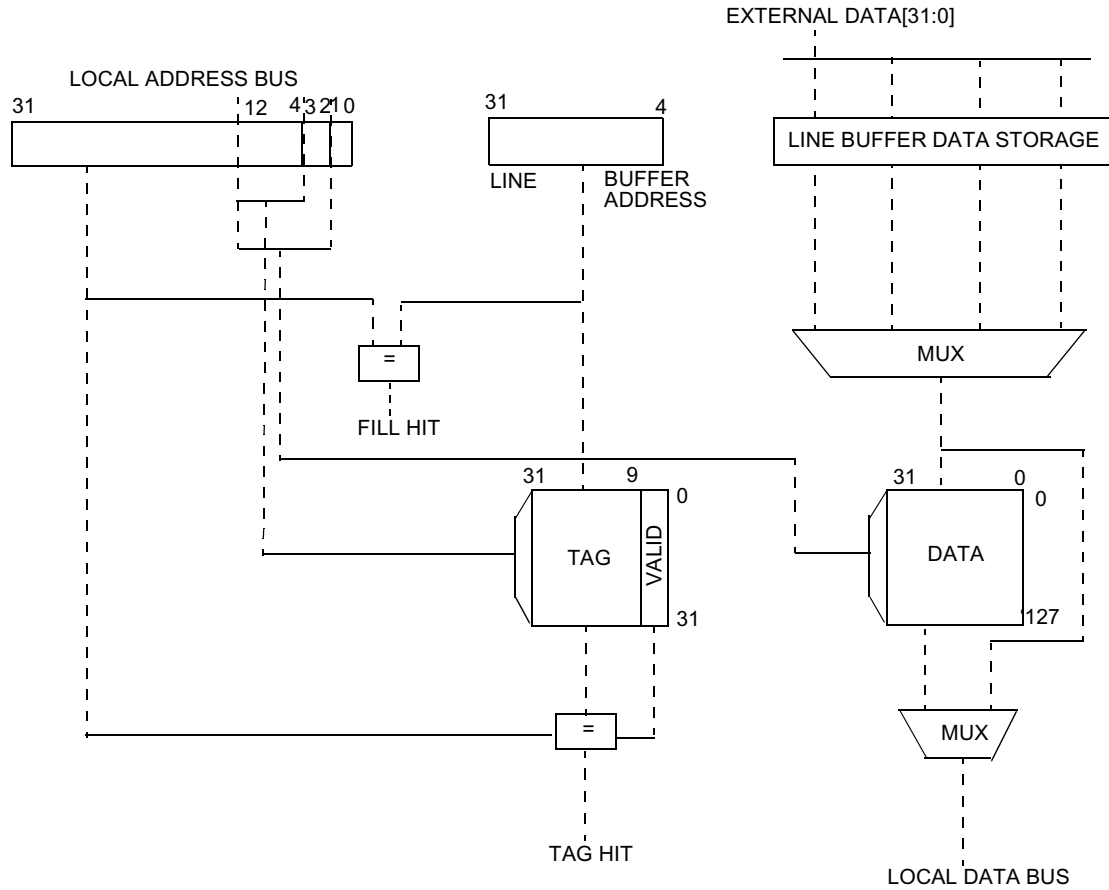

Figure 5-1 Instruction Cache Block Diagram

5.3 INSTRUCTION CACHE OPERATION

The instruction cache is physically connected to the ColdFire core local bus, allowing it to service all instruction fetches from the ColdFire core and certain memory fetches initiated by the debug module. Typically, the debug module's memory references appear as supervisor data accesses but the unit can be programmed to generate user-mode accesses and/or instruction fetches. The instruction cache processes any instruction fetch access in the normal manner.

5.3.1 INTERACTION WITH OTHER MODULES

Because both the instruction cache and high-speed SRAM module are connected to the ColdFire core local data bus, certain user-defined configurations can result in simultaneous instruction fetch processing.

If the referenced address is mapped into the SRAM module, that module will service the request in a single cycle. In this case, data accessed from the instruction cache is simply discarded and no external memory references are generated. If the address is not mapped into the SRAM space, the instruction cache handles the request in the normal fashion.

5.3.2 MEMORY REFERENCE ATTRIBUTES

For every memory reference the ColdFire core or the debug module generates, a set of “effective attributes” is determined based on the address and the Access Control Registers (ACR0, ACR1). This set of attributes includes the cacheable/noncacheable definition, the precise/imprecise handling of operand write, and the write-protect capability.

In particular, each address is compared to the values programmed in the Access Control Registers (ACR). If the address matches one of the ACR values, the access attributes from that ACR are applied to the reference. If the address does not match either ACR, then the default value defined in the Cache Control Register (CACR) is used. The specific algorithm is as follows:

```

if (address = ACR0_address including mask)
Effective Attributes = ACR0 attributes
else if (address = ACR1_address including mask)
Effective Attributes = ACR1 attributes
else Effective Attributes = CACR default attributes

```

5.3.3 CACHE COHERENCY AND INVALIDATION

The instruction cache does not monitor ColdFire core data references for accesses to cached instructions. Therefore, software must maintain cache coherency by invalidating the appropriate cache entries after modifying code segments.

The cache invalidation can be performed in two ways. The assertion of bit 24 in the CACR forces the entire instruction cache to be marked as invalid. The invalidation operation requires 512 cycles because the cache sequences through the entire tag array, clearing a single location each cycle. Any subsequent instruction fetch accesses are postponed until the invalidation sequence is complete.

The privileged CPUSHL instruction can invalidate a single cache line. When this instruction is executed, the cache entry defined by bits[12:4] of the source address register is invalidated, provided bit 28 of the CACR is cleared.

These invalidation operations can be initiated from the ColdFire core or the debug module.

5.3.4 RESET

A hardware reset clears the CACR disabling the instruction cache. The contents of the tag array are not affected by the reset. Accordingly, the system startup code must explicitly perform a cache invalidation by setting CACR[24] before the cache can be enabled.

5.3.5 CACHE MISS FETCH ALGORITHM/LINE FILLS

As detailed in [Section 5.2 Instruction Cache Physical Organization](#), the instruction cache hardware includes a 16-byte line fill buffer for providing temporary storage for the last fetched instruction.

With the cache enabled as defined by CACR[31], a cacheable instruction fetch that misses in both the tag memory and the line-fill buffer generates an external fetch. The size of the external fetch is determined by the value contained in the 2-bit CLNF field of the CACR and the miss address. [Table 5-1](#) shows the relationship between the CLNF bits, the miss address, and the size of the external fetch.

Depending on the runtime characteristics of the application and the memory response speed, overall performance may be increased by programming the CLNF bits to values {00, 01}.

Table 5-1 Initial Fetch Offset vs. CLNF Bits

CLNF[1:0]	LONGWORD ADDRESS BITS			
	00	01	10	11
00	Line	Line	Line	Longword
01	Line	Line	Longword	Longword
1X	Line	Line	Line	Line

For all cases of a line-sized fetch, the critical longword defined by bits [3:2] of the miss address is accessed first followed by the remaining three longwords that are accessed by incrementing the longword address in a modulo-16 fashion is shown in the following example code:

```

if miss address[3:2] = 00
  fetch sequence = {$0, $4, $8, $C}
if miss address[3:2] = 01
  fetch sequence = {$4, $8, $C, $0}
if miss address[3:2] = 10
  fetch sequence = {$8, $C, $0, $4}
if miss address[3:2] = 11
  fetch sequence = {$C, $0, $4, $8}

```

Once an external fetch has been initiated and the data loaded into the line-fill buffer, the instruction cache maintains a special “most-recently-used” indicator that tracks the contents of the fill buffer versus its corresponding cache location. At the time of the miss, the hardware indicator is set, marking the fill buffer as “most recently used.” If a subsequent access occurs to the cache location defined by bits [8:4] of the fill buffer address, the data in the cache memory array is now most recently used, so the hardware indicator is cleared. In all cases, the indicator defines whether the contents of the line fill buffer or the memory data array are most recently used. At the time of the next cache miss, the contents of the line-fill buffer are written into the memory array if the entire line is present, and the fill buffer data is still most recently used compared to the memory array.

The fill buffer can also be used as temporary storage for line-sized bursts of non-cacheable references under control of CACR[10]. With this bit set, a noncacheable instruction fetch is processed as defined by [Table 5-2](#). For this condition, the fill buffer is loaded and subsequent references can hit in the buffer, but the data is never loaded into the memory array.

The following table shows the relationship between CACR bits 31 and 10 and the type of instruction fetch.

Table 5-2 Instruction Cache Operation as Defined by CACR[31,10]

CACR[31]	CACR[10]	TYPE OF INSTR. FETCH	DESCRIPTION
0	0	N/A	Instruction cache is completely disabled; all fetches are word, longword in size.
0	1	N/A	All fetches are word, longword in size
1	X	Cacheable	Fetch size is defined by Table 4-1 and contents of the line-fill buffer can be written into the memory array
1	0	Noncacheable	All fetches are longword in size, and not loaded into the line-fill buffer
1	1	Noncacheable	Fetch size is defined by Table 4-1 and loaded into the line-fill buffer, but are never written into the memory array.

5.4 INSTRUCTION CACHE PROGRAMMING MODEL

Three supervisor registers define the operation of the instruction cache and local bus controller: the Cache Control Register (CACR) and two Access Control Registers (ACR0, ACR1).

5.4.1 INSTRUCTION CACHE REGISTERS MEMORY MAP

Table 5-3 shows the memory map of the Instruction cache and access control registers.

The following list describes several key issues regarding the programming model table:

- The Cache Control Register and Access Control Registers can only be accessed in supervisor mode using the MOVEC instruction with an Rc value of \$002, \$004 and \$005, respectively.
- Addresses not assigned to the registers and undefined register bits are reserved for future expansion. Write accesses to these reserved address spaces and reserved register bits have no effect; read accesses will return zeros.
- The reset value column indicates the initial value of the register at reset. Certain registers may be uninitialized upon reset, i.e., they may contain random values after reset.

The access column indicates if the corresponding register allows both read/write functionality (R/W), read-only functionality (R), or write-only functionality (W). If a read access to a write-only register is attempted, zeros will be returned. If a write access to a read-only register is attempted the access will be ignored and no write will occur.

Table 5-3 Memory Map of I-Cache Registers

ADDRESS	NAME	WIDTH	DESCRIPTION	RESET VALUE	ACCESS
MOVEC with \$002	CACR	32	Cache Control Register	\$0000	W
MOVEC with \$004	ACR0	32	Access Control Register 0	\$0000	W
MOVEC with \$005	ACR1	32	Access Control Register 1	\$0000	W

5.4.2 INSTRUCTION CACHE REGISTER

5.4.2.1 CACHE CONTROL REGISTER

The CACR controls the operation of the instruction cache. The CACR provides a set of default memory access attributes used when a reference address does not map into the spaces defined by the ACRs.

The CACR is a 32-bit write-only supervisor control register. It is accessed in the CPU address space using the MOVEC instruction with an Rc encoding of \$002. The CACR can be read when in Background Debug mode (BDM). At system reset, the entire register is cleared.

Table 5-4 Cache Control Register (CACR)

BITS	31	30	29	28	27	26	25	24	23	22	21	20	19	18	17	16
FIELD	CENB			CPDI	CFRZ											
RESET	0	0	0	0	0	0	0	0	0	0	0	0	0	0	0	0
R/W	R/W			R/W	R/W											
BITS	15	14	13	12	11	10	9	8	7	6	5	4	3	2	1	0
FIELD						CEIB	DCM	DBWE		DWP					CLNF1	CLNF2
RESET	0	0	0	0	0	0	0	0	0	0	0	0	0	0	0	0
R/W						R/W	R/W	R/W		R/W					R/W	R/W

Table 5-5 Cache Control Bit Descriptions

BIT NAME	DESCRIPTION
CENB	<p>The Cache Enable bit generally provides longword references used for sequential fetches. If the processor branches to an odd word address, a word-sized fetch is generated. The memory array of the instruction cache is enabled only if CENB is asserted.</p> <p>0 = Cache disabled 1 = Cache enabled</p>
CPDI	<p>When the disable CPUSHL Invalidation instruction is executed, the cache entry defined by bits [8:4] of the address is invalidated if CPDI = 0. If CPDI = 1, no operation is performed.</p> <p>0 = Enable invalidation 1 = Disable invalidation</p>
CFRZ	<p>The Cache Freeze bit allows users to freeze the contents of the cache. When CFRZ is asserted line fetches can be initiated and loaded into the line-fill buffer, but a valid cache entry can not be overwritten. If a given cache location is invalid, the contents of the line-fill buffer can be written into the memory array while CFRZ is asserted.</p> <p>0 = Normal Operation 1 = Freeze valid cache lines</p>
CINV	<p>The Cache Invalidate bit forces the cache to invalidate each tag array entry. The invalidation process requires 32 machine cycles, with a single cache entry cleared per machine cycle. The state of this bit is always read as a zero. After a hardware reset, the cache must be invalidated before it is enabled.</p> <p>0 = No operation 1 = Invalidate all cache locations</p>
CEIB	<p>The Cache Enable Noncacheable Instruction Bursting bit enables the line-fill buffer to be loaded with burst transfers under control of CLINF[1:0] for non-cacheable accesses. Noncacheable accesses are never written into the memory array.</p> <p>0 = Disable burst fetches on noncacheable accesses 1 = Enable burst fetches on noncacheable accesses</p>
DCM	<p>The Default Cache Mode bit defines the default cache mode: 0 is cacheable, 1 is noncacheable.</p> <p>0 = Default cacheable 1 = Default noncacheable</p>
DBWE	<p>The Default Buffered Write Enable bit defines the default value for enabling buffered writes. If DBWE = 0, the termination of an operand write cycle on the processor's local bus is delayed until the external bus cycle is completed. If DBWE = 1, the write cycle on the local bus is terminated immediately and the operation buffered in the bus controller. In this mode, operand write cycles are effectively decoupled between the processor's local bus and the external bus.</p> <p>Generally, enabled buffered writes provide higher system performance but recovery from access errors can be more difficult. For the ColdFire CPU, reporting access errors on operand writes is always imprecise and enabling buffered writes simply further decouples the write instruction from the signaling of the fault.</p> <p>0 = Disable buffered writes 1 = Enable buffered writes</p>
DWP	<p>Default Write Protection</p> <p>0 = Read and write accesses permitted 1 = Only read accesses permitted</p>
CLNF[1:0]	<p>The Cache Line Fill bits control the size of the memory request the cache issues to the bus controller for different initial line access offsets. The following table shows the fetch size.</p>

Table 5-6 External Fetch Size Based on Miss Address and CLNF

CLNF[1:0]	LONGWORD ADDRESS BITS			
	00	01	10	11
00	Line	Line	Line	Longword
01	Line	Line	Longword	Longword
10	Line	Line	Line	Line
11	Line	Line	Line	Line

5.4.2.2 ACCESS CONTROL REGISTERS

The access control registers ACR0 and ACR1, provide a definition of memory reference attributes for two memory regions (one per ACR). This set of effective attributes is defined for every memory reference using the ACRs or the set of default attributes contained in the CACR. The ACRs are examined for every memory reference that is NOT mapped to the SRAM module.

The ACRs are 32-bit write-only supervisor control registers. They are accessed in the CPU address space using the MOVEC instruction with an Rc encoding of \$004 and \$005. The ACRs can be read when in background debug mode (BDM). At system reset, the registers are cleared.

Table 5-7 Access Control Registers (ACR0, ACR1)

BITS	31	30	29	28	27	26	25	24	23	22	21	20	19	18	17	16
FIELD	BA31	BA30	BA29	BA28	BA27	BA26	BA25	BA24	BAM3 1	BAM3 0	BAM29	BAM 28	BAM2 7	BAM2 6	BAM2 5	BAM2 4
RESET	0	0	0	0	0	0	0	0	0	0	0	0	0	0	0	0
R/W	R/W	R/W	R/W	R/W	R/W	R/W	R/W	R/W	R/W	R/W	R/W	R/W	R/W	R/W	R/W	R/W
BITS	15	14	13	12	11	10	9	8	7	6	5	4	3	2	1	0
FIELD	EN	SM1	SM0							CM	BWE			WP		
RESET	0	0	0	0	0	0	0	0	0	0	0	0	0	0	0	0
R/W	R/W	R/W	R/W							R/W	R/W			R/W		

Table 5-8 Access Control Bit Descriptions

BIT NAME	DESCRIPTION
AB[31:24]	The Address Base [31:24] 8-bit field is compared to address bits [31:24] from the processor's local bus under control of the ACR address mask. If the address matches, the attributes for the memory reference are sourced from the given ACR.
AM[31:24]	The Address Mask [31:24] 8-bit field can mask any bit of the AB field comparison. If a bit in the AM field is set, then the corresponding bit of the address field comparison is ignored.
EN	The Enable bit defines the ACR enable. Hardware reset clears this bit, disabling the ACR. 0 = ACR disabled 1 = ACR enabled
SM[1:0]	The Supervisor mode two-bit field allows the given ACR to be applied to references based on operating privilege mode of the ColdFire processor. The field uses the ACR for user references only, supervisor references only, or all accesses. 00 = Match if user mode 01 = Match if supervisor mode 1x = Match always - ignore user/supervisor mode
CM	The Cache Mode bit defines the cache mode: 0 is cacheable, 1 is noncacheable. 0 = Caching enabled 1 = Caching disabled
BWE	The Buffered Write Enable bit defines the value for enabling buffered writes. If BWE = 0, the termination of an operand write cycle on the processor's local bus is delayed until the external bus cycle is completed. If BWE = 1, the write cycle on the local bus is terminated immediately and the operation is then buffered in the bus controller. In this mode, operand write cycles are effectively decoupled between the processor's local bus and the external bus. Generally, the enabling of buffered writes provides higher system performance but recovery from access errors may be more difficult. For the ColdFire CPU, the reporting of access errors on operand writes is always imprecise, and enabling buffered writes simply decouples the write instruction from the signaling of the fault even more. 0 = Don't buffer writes 1 = Buffer writes
WP	The Write Protect bit defines the write-protection attribute. If the effective memory attributes for a given access select the WP bit, an access error terminates any attempted write with this bit set. 0 = Read and write accesses permitted 1 = Only read accesses permitted

NOTES

Section 6

Static RAM (SRAM)

6.1 SRAM FEATURES

- One 64 KByte and one 32 KByte SRAMS
- Single-cycle access
- Physically located on processor's high-speed local bus
- Memory location programmable on any 32 KByte address
- Byte, word, longword address capabilities

6.2 SRAM OPERATION

The SRAM module provides a general-purpose memory block that the ColdFire processor can access in a single cycle. The location of the memory block can be specified to any modulo-16K address within the 4-GByte address space. The memory is ideal for storing critical code or data structures or for use as the system stack. Because the SRAM module is physically connected to the processor's high-speed local bus, it can service processor-initiated access or memory-referencing commands from the debug module.

Depending on configuration information, instruction fetches may be sent to both the cache and the SRAM block simultaneously. If the reference is mapped into the region defined by the SRAM, the SRAM provides the data back to the processor, and the cache data discarded. Accesses from the SRAM module are not cached.

The first SRAM, SRAM0 (32 KBytes) cannot be accessed by the on-chip DMAs of the MCF5249. The second SRAM, SRAM1 (64 Kbytes), can be accessed by the on-chip DMAs. SRAM0 is made up of one memory array consisting of 2048 lines, each containing 16 Bytes. However, SRAM1 is made up of two memory arrays each consisting of 2048 lines, with 16 Bytes in each line. The SRAM1 array is split (Upper 32K bank and Lower 32K bank) to allow simultaneous access to both arrays by both the DMA and the CPU. [Figure 1-1](#), the MCF5249 block diagram, shows this concept.

6.3 SRAM PROGRAMMING MODEL

The SRAM programming model includes a description of the SRAM base address register (RAMBAR), SRAM initialization, and power management.

6.3.1 SRAM BASE ADDRESS REGISTER

The configuration information in the SRAM Base Address Register (RAMBAR[0:1]) controls the operation of the SRAM module.

- There are 2 RAMBAR registers. One for SRAM0, the second for SRAM1.
- The RAMBAR is the register that holds the base address of the SRAM. The MOVEC instruction provides write-only access to this register.
- The RAMBAR registers can be read or written from the Debug module in a similar manner.
- All undefined bits in the register are reserved. These bits are ignored during writes to the RAMBAR, and return zeroes when read from the debug module.
- The RAMBAR valid bit is cleared by reset, disabling the SRAM module. All other bits are unaffected.

Freescale Semiconductor, Inc.

SRAM Programming Model

The RAMBAR register contains several control fields. These fields are detailed in the following tables.

Table 6-1 SRAM Base Address Register (RAMBAR0)

BITS	31	30	29	28	27	26	25	24	23	22	21	20	19	18	17	16
FIELD	BA31	BA30	BA29	BA28	BA27	BA26	BA25	BA24	BA23	BA22	BA21	BA20	BA19	BA18	BA17	BA16
RESET	—	—	—	—	—	—	—	—	—	—	—	—	—	—	—	—
R/W	R/W	R/W	R/W	R/W	R/W	R/W	R/W	R/W	R/W	R/W	R/W	R/W	R/W	R/W	R/W	R/W
BITS	15	14	13	12	11	10	9	8	7	6	5	4	3	2	1	0
FIELD	BA15	BA14						WP			C/I	SC	SD	UC	UD	V
RESET	—	—	—	—	—	—	—	—	—	—	—	—	—	—	—	0
R/W	R/W	R/W						R/W			R/W	R/W	R/W	R/W	R/W	R/W
CPU + \$C04																

Table 6-2 SRAM1 Base Address Register (RAMBAR1)

BITS	31	30	29	28	27	26	25	24	23	22	21	20	19	18	17	16
FIELD	BA31	BA30	BA29	BA28	BA27	BA26	BA25	BA24	BA23	BA22	BA21	BA20	BA19	BA18	BA17	BA16
RESET	—	—	—	—	—	—	—	—	—	—	—	—	—	—	—	—
R/W	R/W	R/W	R/W	R/W	R/W	R/W	R/W	R/W	R/W	R/W	R/W	R/W	R/W	R/W	R/W	R/W
BITS	15	14	13	12	11	10	9	8	7	6	5	4	3	2	1	0
FIELD	BA15	BA14			PRI1	PRI2	SPV	WP			C/I	SC	SD	UC	UD	V
RESET	—	—	—	—	—	—	—	—	—	—	—	—	—	—	—	0
R/W	R/W	R/W			R/W	R/W	R/W	R/W			R/W	R/W	R/W	R/W	R/W	R/W
CPU + \$C05																

Table 6-3 Cache Control Bit Descriptions

BIT NAME	DESCRIPTION															
BA[31:14]	The Base Address field defines the 0-modulo-16K base address of the SRAM module. The SRAM memory occupies a 16KByte space defined by the contents of the Base Address field. By programming this field, the SRAM may be located on any 16KByte boundary within the processor's four gigabyte address space.															
PRI1, PRI2	<p>The PRI1 priority bit (only SRAM1) determines if DMA or CPU has priority in upper 32k bank of memory. PRI2 determines if DMA or CPU has priority in lower 32k bank of memory. If bit is set, DMA has priority. If bit is reset, CPU has priority. Priority is determined by the following table:</p> <table border="1" data-bbox="610 604 1182 905"> <thead> <tr> <th data-bbox="610 604 802 688">PRI[1:2]</th> <th data-bbox="807 604 992 688">UPPER BANK PRIORITY</th> <th data-bbox="997 604 1182 688">LOWER BANK PRIORITY</th> </tr> </thead> <tbody> <tr> <td data-bbox="610 695 802 741">2'b00</td> <td data-bbox="807 695 992 741">CPU Accesses</td> <td data-bbox="997 695 1182 741">CPU Accesses</td> </tr> <tr> <td data-bbox="610 747 802 793">2'b01</td> <td data-bbox="807 747 992 793">CPU Accesses</td> <td data-bbox="997 747 1182 793">DMA Accesses</td> </tr> <tr> <td data-bbox="610 800 802 846">2'b10</td> <td data-bbox="807 800 992 846">DMA Accesses</td> <td data-bbox="997 800 1182 846">CPU Accesses</td> </tr> <tr> <td data-bbox="610 852 802 898">2'b11</td> <td data-bbox="807 852 992 898">DMA Accesses</td> <td data-bbox="997 852 1182 898">DMA Accesses</td> </tr> </tbody> </table>	PRI[1:2]	UPPER BANK PRIORITY	LOWER BANK PRIORITY	2'b00	CPU Accesses	CPU Accesses	2'b01	CPU Accesses	DMA Accesses	2'b10	DMA Accesses	CPU Accesses	2'b11	DMA Accesses	DMA Accesses
PRI[1:2]	UPPER BANK PRIORITY	LOWER BANK PRIORITY														
2'b00	CPU Accesses	CPU Accesses														
2'b01	CPU Accesses	DMA Accesses														
2'b10	DMA Accesses	CPU Accesses														
2'b11	DMA Accesses	DMA Accesses														
SPV	<p>Allow DMA access (only SRAM1)</p> <p>0 = DMA access to memory is disabled.</p> <p>1 = DMA access to memory is enabled.</p>															
WP	<p>The Write Protect field allows only read accesses to the SRAM. When this bit is set, any attempted write access will generate an access error exception to the ColdFire processor core.</p> <p>0 = Allows read and write accesses to the SRAM module</p> <p>1 = Allows only read accesses to the SRAM module</p>															
C/I, SC, SD, UC, UD	<p>Address Space Masks (ASn)</p> <p>These five bit fields allow certain types of accesses to be "masked," or inhibited from accessing the SRAM module. The address space mask bits are:</p> <p>C/I = CPU space/interrupt acknowledge cycle mask</p> <p>SC = Supervisor code address space mask</p> <p>SD = Supervisor data address space mask</p> <p>UC = User code address space mask</p> <p>UD = User data address space mask</p> <p>For each address space bit:</p> <p>0 = An access to the SRAM module can occur for this address space</p> <p>1 = Disable this address space from the SRAM module. If a reference using this address space is made, it is inhibited from accessing the SRAM module, and is processed like any other non-SRAM reference.</p> <p>These bits are useful for power management as detailed in Section 6.3.4.</p>															
V	<p>The valid bit (V-bit) is specified by RAMBAR[0:1]. A hardware reset clears this bit. When set, this bit enables the SRAM module; otherwise, the module is disabled.</p> <p>0 = Contents of RAMBAR are not valid</p> <p>1 = Contents of RAMBAR are valid</p>															

6.3.2 SRAM INITIALIZATION

After a hardware reset, the contents of the SRAM module are undefined. The valid bit of the RAMBAR is cleared, disabling the module. If the SRAM requires initialization with instructions or data, the following steps should be performed:

1. Load the RAMBAR mapping the SRAM module to the desired location within the address space.
2. Read the source data and write it to the SRAM. There are various instructions to support this function, including memory-to-memory move instructions, or the MOVEM opcode. The MOVEM instruction is optimized to generate line-sized burst fetches on 0-modulo-16 addresses, so this opcode generally provides maximum performance.
3. After the data has been loaded into the SRAM, it may be appropriate to load a revised value into the RAMBAR with a new set of attributes. These attributes consist of the write-protect and address space mask fields.

The ColdFire processor or an external emulator using the debug module can perform these initialization functions.

6.3.3 SRAM INITIALIZATION CODE

The following code segment describes how to initialize the SRAM. The code sets the base address of the SRAM at \$20000000 and then initializes the RAM to zeros.

```
RAMBASE EQU $20000000 set this variable to $20000000
RAMVALID EQU $00000000
move.l #RAMBASE+RAMVALID,D0;load RAMBASE + valid bit into D0.
movec.l D0, RAMBAR;load RAMBAR and enable SRAM
```

The following loop initializes the entire SRAM to zero

```
lea.l RAMBASE,A0;load pointer to SRAM
move.l #1024,D0;load loop counter into D0
```

```
SRAM_INIT_LOOP:
clr.l (A0)+; clear 4 bytes of SRAM
subq.l #1,D0;decrement loop counter
bne.b SRAM_INIT_LOOP;if done, then exit; else continue looping
```

6.3.4 POWER MANAGEMENT

As noted previously, depending on the configuration defined by the RAMBAR, instruction fetch and operand read accesses may be sent to the SRAM and unified cache simultaneously. If the access is mapped to the SRAM module, it sources the read data, and the unified cache access is discarded. If the SRAM is used only for data operands, asserting the ASn bits associated with instruction fetches can decrease power dissipation. Additionally, if the SRAM contains only instructions, masking operand accesses can reduce power dissipation. The following table shows some examples of typical RAMBAR settings.

Table 6-4 Typical RAMBAR Setting Examples

DATA CONTAINED IN SRAM	RAMBAR[7:0]
Code Only	\$2B
Data Only	\$35
Both Code And Data	\$21

Section 7

Synchronous DRAM Controller Module

7.1 DRAM FEATURES

The key features of the DRAM controller include the following:

- Support for two independent blocks of DRAM
- Interface to standard synchronous dynamic random access memory (SDRAM) components
- Programmable $\overline{\text{SDRAS}}$, $\overline{\text{SDCAS}}$, and refresh timing
- Support for page mode
- Support for 16- wide DRAM blocks

7.1.1 DEFINITIONS

The following terminology is used in this section:

- SDRAM block—Any group of DRAM memories selected by one of the MCF5249 $\overline{\text{SDRAM_CS1}}$, $\overline{\text{SDRAM_CS2}}$ signals. Thus, the MCF5249 can support two independent memory blocks. The base address of each block is programmed in the DRAM address and control registers (DACR0 and DACR1).
- SDRAM—RAMs that operate like asynchronous DRAMs but with a synchronous clock, a pipelined, multiple-bank architecture, and faster speed.
- SDRAM bank—An internal partition in an SDRAM device. For example, a 64-Mbit SDRAM component might be configured as four 512K x 32 banks. Banks are selected through the SDRAM component's bank select lines.

Note:The SDRAM_CS2 signal is only used in the 160 MAPBGA package.

7.1.2 BLOCK DIAGRAM AND MAJOR COMPONENTS

The basic components of the DRAM controller are shown in [Figure 7-1](#).

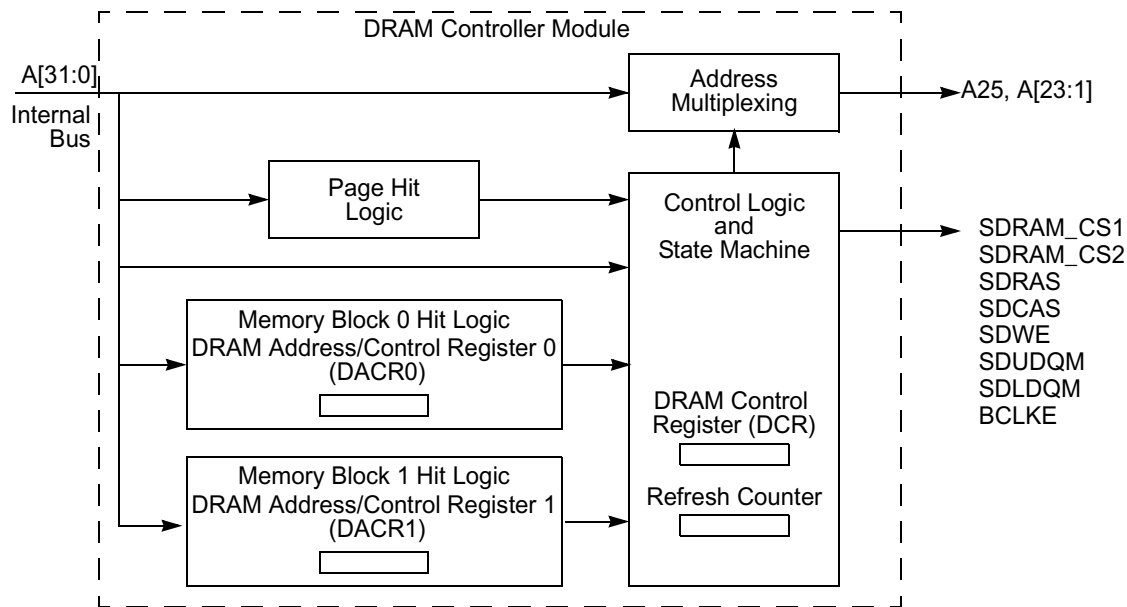

Figure 7-1 Synchronous DRAM Controller Block Diagram

The DRAM controller's major components, shown in [Figure 7-1](#), are described as follows:

- DRAM address and control registers (DACR0 and DACR1)—The DRAM controller consists of two configuration register units, one for each supported memory block. DACR0 is accessed at MBAR + 0x0108; DACR1 is accessed at 0x0110. The register information is passed on to the hit logic.
- Control logic and state machine—Generates all DRAM signals, taking bus cycle characteristic data from the block logic, along with hit information to generate DRAM accesses. Handles refresh requests from the refresh counter.
 - DRAM control register (DCR)—Contains data to control refresh operation of the DRAM controller. Both memory blocks are refreshed concurrently as controlled by DCR[RC].
 - Refresh counter—Determines when refresh should occur, determined by the value of DCR[RC]. It generates a refresh request to the control block.
- Hit logic—Compares address and attribute signals of a current DRAM bus cycle to both DACRs to determine if a DRAM block is being accessed. Hits are passed to the control logic along with characteristics of the bus cycle to be generated.
- Page hit logic—Determines if the next DRAM access is in the same DRAM page as the previous one. This information is passed on to the control logic.
- Address multiplexing—Multiplexes addresses to allow column and row addresses to share pins. This allows glueless interface to DRAMs.

7.2 DRAM CONTROLLER OPERATION

7.2.1 DRAM CONTROLLER REGISTERS

The DRAM controller registers memory map is shown in [Table 7-1](#)

Table 7-1 DRAM Controller Registers

MBAR OFFSET	[31:24]	[23:16]	[15:8]	[7:0]
0x100	DRAM control register (DCR) [See Section 7.2.1]		Reserved	
0x104	Reserved			
0x108	DRAM address and control register 0 (DACR0) [See Section 7.3.2.2.]			
0x10C	DRAM mask register block 0 (DMR0) [See Section 7.3.2.3.]			
0x110	DRAM address and control register 1 (DACR1) [See Section 7.3.2.2.]			
0x114	DRAM mask register block 1 (DMR1) [See Section 7.3.2.3.]			

7.3 SYNCHRONOUS OPERATION

By running synchronously with the system clock, SDRAM can (after an initial latency period) be accessed on every clock; 5-1-1-1 is a typical MCF5249 burst rate to SDRAM.

Note: Because the MCF5249 cannot have more than one page open at a time, it does not support interleaving.

Table 7-2 lists common SDRAM commands.

Table 7-2 SDRAM Commands

COMMAND	DEFINITION
ACTV	Activate. Executed before READ or WRITE executes; SDRAM registers and decodes row address.
MRS	Mode register set.
NOP	No-op. Does not affect SDRAM state machine; DRAM controller control signals negated; SDRAM_CS asserted.
PALL	Precharge all. Precharges all internal banks of an SDRAM component; executed before new page is opened.
READ	Read access. SDRAM registers column address and decodes that a read access is occurring.
REF	Refresh. Refreshes internal bank rows of an SDRAM component.
SELF	Self refresh. Refreshes internal bank rows of an SDRAM component when it is in low-power mode.
SELFx	Exit self refresh. This command is sent to the DRAM controller when DCR[IS] is cleared.
WRITE	Write access. SDRAM registers column address and decodes that a write access is occurring.

Commands are issued to memory using specific encoding on address and control pins. Soon after system reset, a command must be sent to the SDRAM mode register to configure SDRAM operating parameters.

Synchronous Operation

Note:After synchronous operation is selected by setting DCR[SO], DRAM controller registers reflect the synchronous operation.

7.3.1 DRAM CONTROLLER SIGNALS IN SYNCHRONOUS MODE

Table 7-3 shows the behavior of DRAM signals in synchronous mode.

Table 7-3 Synchronous DRAM Signal Connections

Signal	Description
SDRAS	Synchronous row address strobe. Indicates a valid SDRAM row address is present and can be latched by the SDRAM. SDRAS should be connected to the corresponding SDRAM SRAS.
SDCAS	Synchronous column address strobe. Indicates a valid column address is present and can be latched by the SDRAM. SDCAS should be connected to the corresponding signal labeled SCAS on the SDRAM.
SDWE	DRAM read/write. Asserted for write operations and negated for read operations.
SDRAM_CS1 SDRAM_CS2	Select each memory block of SDRAMs connected to the MCF5249. One signal selects one SDRAM block and connects to the corresponding CS signals.
BCLKE	Synchronous DRAM clock enable. Connected directly to the CKE (clock enable) signal of SDRAMs. Enables and disables the clock internal to SDRAM. When BCLKE is low, memory can enter a power-down mode where operations are suspended or they can enter self-refresh mode. BCLKE functionality is controlled by DCR[COC]. For designs using external multiplexing, setting COC allows BCLKE to provide command-bit functionality.
UDQM LDQM	Column address strobe. For synchronous operation, UDQM, LDQM function as byte enables to the SDRAMs. They connect to the DQM signals (or mask qualifiers) of the SDRAMs.
BCLK	Bus clock output. Connects to the CLK input of SDRAMs.

Note:The SDRAM_CS2 is only used in the 160 MAPBGA package.

Figure 7-2 shows a typical signal configuration for synchronous mode.

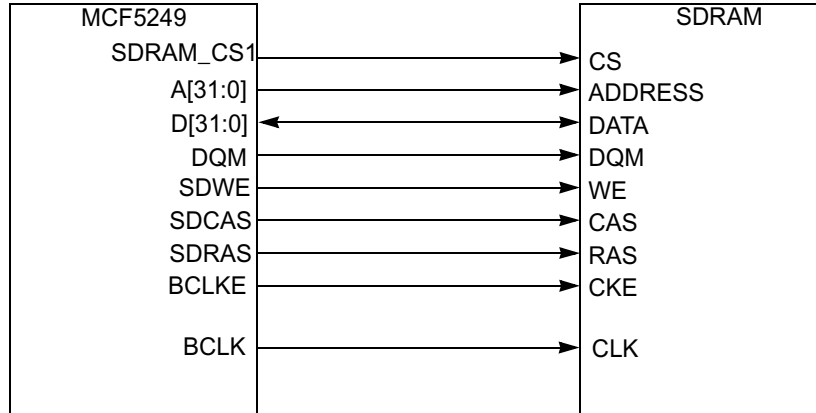

Figure 7-2 MCF5249 SDRAM Interface

7.3.2 SYNCHRONOUS REGISTER SET

The memory map is shown in Table 7-1. Bit descriptions are shown in the following sections.

7.3.2.1 DRAM CONTROL REGISTER (DCR) (SYNCHRONOUS MODE)

The DRAM control register (DCR), Figure 7-3, controls refresh logic.

	15	14	13	12	11	10	9	8	7	6	5	4	3	2	1	0
Field	SO	—	NAM	COC	IS	RTIM	RC									
Reset	0	Uninitialized														
R/W	R/W															
Addr	MBAR + 0x100															

Figure 7-3 DRAM Control Register (DCR) (Synchronous Mode)

Table 7-4 describes DCR fields.

Table 7-4 DCR Field Descriptions (Synchronous Mode)

BITS	NAME	DESCRIPTION
15	SO	Synchronous operation. Selects synchronous or asynchronous mode. When in synchronous mode, the DRAM controller can be switched to ADRAM mode only by resetting the MCF5249. 0 Asynchronous DRAMs. Default at reset. Do not use. 1 Synchronous DRAMs Note: bit setting SO=0 is a legacy mode. Do not use. First action must always be to set this bit one.
14	—	Reserved, should be cleared.
13	NAM	No address multiplexing. Some implementations require external multiplexing. For example, when linear addressing is required, the DRAM should not multiplex addresses on DRAM accesses. 0 The DRAM controller multiplexes the external address bus to provide column addresses. 1 The DRAM controller does not multiplex the external address bus to provide column addresses.
12	COC	Command on SDRAM clock enable (SCKE). Implementations that use external multiplexing (NAM = 1) must support command information to be multiplexed onto the SDRAM address bus. 0 SCKE functions as a clock enable; self-refresh is initiated by the DRAM controller through DCR[IS]. 1 SCKE drives command information. Because SCKE is not a clock enable, self-refresh cannot be used (setting DCR[IS]). Thus, external logic must be used if this functionality is desired. External multiplexing is also responsible for putting the command information on the proper address bit.
11	IS	Initiate self-refresh command. 0 Take no action or issue a SELFX command to exit self refresh. 1 If DCR[COC] = 0, the DRAM controller sends a SELF command to both SDRAM blocks to put them in low-power, self-refresh state where they remain until IS is cleared, at which point the controller sends a SELFX command for the SDRAMs to exit self-refresh. The refresh counter is suspended while the SDRAMs are in self-refresh; the SDRAM controls the refresh period.
10–9	RTIM	Refresh timing. Determines the timing operation of auto-refresh in the DRAM controller. Specifically, it determines the number of clocks inserted between a REF command and the next possible ACTV command. This same timing is used for both memory blocks controlled by the DRAM controller. This corresponds to t_{RC} in the SDRAM specifications. 00 3 clocks 01 6 clocks 1x 9 clocks
8–0	RC	Refresh count. Controls refresh frequency. The number of bus clocks between refresh cycles is $(RC + 1) * 16$. Refresh can range from 16–8192 bus clocks to accommodate both standard and low-power DRAMs with bus clock operation from less than 2 MHz to greater than 50 MHz. The following example calculates RC for an auto-refresh period for 4096 rows to receive 64 mS of refresh every 15.625 μ s for each row (625 bus clocks at 40 MHz). $\#$ of bus clocks = 625 = $(RC \text{ field} + 1) * 16$ $RC = (625 \text{ bus clocks}/16) - 1 = 38.06$, which rounds to 38; therefore, RC = 0x26.

7.3.2.2 DRAM ADDRESS AND CONTROL (DACR0/DACR1) (SYNCHRONOUS MODE)

The DRAM address and control registers (DACR0 and DACR1), shown in Figure 7-4, contain the base address compare value and the control bits for both memory blocks 0 and 1 of the DRAM controller. Address and timing are also controlled by bits in DACRn.

	31	18	17	16	15	14	13	12	11	10	9	8	7	6	5	4	3	2	1	0	
Field	BA				—	RE	—	CAS L	—	CBM	—	IMR S	PS	IP	PM	—					
Reset	Uninitialized				0	Uninitialized				0	Uninitialized										
R/W	R/W																				
Addr	MBAR+0x108 (DACR0); 0x110 (DACR1)																				

Figure 7-4 DACR0 and DACR1 (Synchronous Mode)

Table 7-5 describes DACRn fields.

Table 7-5 DACR0/DACR1 Field Descriptions (Synchronous Mode)

BIT	NAME	DESCRIPTION																																							
31–18	BA	Base address register. With DCMR[BAM], determines the address range in which the associated DRAM block is located. Each BA bit is compared with the corresponding address of the current bus cycle. If all unmasked bits match, the address hits in the associated DRAM block.																																							
17–16	—	Reserved, should be cleared.																																							
15	RE	Refresh enable. Determines when the DRAM controller generates a refresh cycle to the DRAM block. 0 Do not refresh associated DRAM block 1 Refresh associated DRAM block																																							
14	—	Reserved, should be cleared.																																							
13–12	CASL	<p>$\overline{\text{CAS}}$ latency. Affects the following SDRAM timing specifications. Timing nomenclature varies with manufacturers. Refer to the SDRAM specification for the appropriate timing nomenclature:</p> <table border="1" style="width: 100%; border-collapse: collapse;"> <thead> <tr> <th rowspan="2">PARAMETER</th> <th colspan="4">NUMBER OF BUS CLOCKS</th> </tr> <tr> <th>CASL=00</th> <th>CASL=01</th> <th>CASL=10</th> <th>CASL=11</th> </tr> </thead> <tbody> <tr> <td>t_{RCD}—$\overline{\text{SRAS}}$ assertion to $\overline{\text{SCAS}}$ assertion</td> <td></td> <td>2</td> <td>3</td> <td>3</td> </tr> <tr> <td>t_{CASL}—$\overline{\text{SCAS}}$ assertion to data out</td> <td></td> <td>1</td> <td>2</td> <td>2</td> </tr> <tr> <td>t_{RAS}—ACTV command to precharge command</td> <td></td> <td>4</td> <td>6</td> <td>6</td> </tr> <tr> <td>t_{RP}—Precharge command to ACTV command</td> <td></td> <td>2</td> <td>3</td> <td>3</td> </tr> <tr> <td>$t_{\text{RWL}}, t_{\text{RD L}}$—Last data input to precharge command</td> <td></td> <td>1</td> <td>1</td> <td>1</td> </tr> <tr> <td>t_{EP}—Last data out to precharge command)</td> <td></td> <td>1</td> <td>1</td> <td>1</td> </tr> </tbody> </table>	PARAMETER	NUMBER OF BUS CLOCKS				CASL=00	CASL=01	CASL=10	CASL=11	t_{RCD} — $\overline{\text{SRAS}}$ assertion to $\overline{\text{SCAS}}$ assertion		2	3	3	t_{CASL} — $\overline{\text{SCAS}}$ assertion to data out		1	2	2	t_{RAS} —ACTV command to precharge command		4	6	6	t_{RP} —Precharge command to ACTV command		2	3	3	$t_{\text{RWL}}, t_{\text{RD L}}$ —Last data input to precharge command		1	1	1	t_{EP} —Last data out to precharge command)		1	1	1
PARAMETER	NUMBER OF BUS CLOCKS																																								
	CASL=00	CASL=01	CASL=10	CASL=11																																					
t_{RCD} — $\overline{\text{SRAS}}$ assertion to $\overline{\text{SCAS}}$ assertion		2	3	3																																					
t_{CASL} — $\overline{\text{SCAS}}$ assertion to data out		1	2	2																																					
t_{RAS} —ACTV command to precharge command		4	6	6																																					
t_{RP} —Precharge command to ACTV command		2	3	3																																					
$t_{\text{RWL}}, t_{\text{RD L}}$ —Last data input to precharge command		1	1	1																																					
t_{EP} —Last data out to precharge command)		1	1	1																																					
11	—	Reserved, should be cleared.																																							

Table 7-5 DACR0/DACR1 Field Descriptions (Synchronous Mode) (Continued)

BIT	NAME	DESCRIPTION
10–8	CBM	<p>Command and bank MUX [2:0]. Because different SDRAM configurations cause the command and bank select lines to correspond to different addresses, these resources are programmable. CBM determines the addresses onto which these functions are multiplexed.</p> <p>CBMCommand Bit Bank Select Bits</p> <p>000 17 18 and up 001 18 19 and up 010 19 20 and up 011 20 21 and up 100 21 22 and up 101 22 23 and up 110 23 24 and up 111 24 25 and up</p> <p>This encoding and the address multiplexing scheme handle common SDRAM organizations. Bank select bits include a base bit and all address bits above for SDRAMs with multiple bank select bits.</p>
7	—	Reserved, should be cleared.
6	IMRS	<p>Initiate mode register set (MRS) command. Setting IMRS generates a MRS command to the associated SDRAMs. In initialization, IMRS should be set only after all DRAM controller registers are initialized and PALL and REFRESH commands have been issued. After IMRS is set, the next access to an SDRAM block programs the SDRAM's mode register. Thus, the address of the access should be programmed to place the correct mode information on the SDRAM address pins. Because the SDRAM does not register this information, it doesn't matter if the IMRS access is a read or a write or what, if any, data is put onto the data bus. The DRAM controller clears IMRS after the MRS command finishes.</p> <p>0 Take no action 1 Initiate MRS command</p>
5–4	PS	<p>Port size. Indicates the port size of the associated block of SDRAM, which allows for dynamic sizing of associated SDRAM accesses.</p> <p>1x 16-bit port 0x Do not use 01 8-bit port</p>
3	IP	<p>Initiate precharge all (PALL) command. The DRAM controller clears IP after the PALL command is finished. Accesses using IP should be no wider than the port size programmed in PS.</p> <p>0 Take no action. 1 A PALL command is sent to the associated SDRAM block. During initialization, this command is executed after all DRAM controller registers are programmed. After IP is set, the next write to an appropriate SDRAM address generates the PALL command to the SDRAM block.</p>
2	PM	<p>Page mode. Indicates how the associated SDRAM block supports page-mode operation.</p> <p>0 Page mode on bursts only. The DRAM controller dynamically bursts the transfer if it falls within a single page and the transfer size exceeds the port size of the SDRAM block. After the burst, the page closes and a precharge is issued. 1 Continuous page mode. The page stays open and only SDCAS needs to be asserted for sequential SDRAM accesses that hit in the same page, regardless of whether the access is a burst.</p>
1–0	—	Reserved, should be cleared.

7.3.2.3 DRAM CONTROLLER MASK REGISTERS (DMR0/DMR1)

The DMR_n, Figure 7-5, includes mask bits for the base address and for address attributes.

	31	18 17	9 8 7 6 5 4 3 2 1 0
Field	BAM		— WP — C/I AM SC SD UC UD V
Reset	Uninitialized		
R/W	R/W		
Addr	MBAR + 0x10C (DMR0), 0x114 (DMR1)		

Figure 7-5 DRAM Controller Mask Registers (DMR0 and DMR1)

Table 7-6 describes DMR_n fields.

Table 7-6 DMR0/DMR1 Field Descriptions

BITS	NAME	DESCRIPTION																					
31–18	BAM	Base address mask. Masks the associated DACR _n [BA]. Lets the DRAM controller connect to various DRAM sizes. Mask bits need not be contiguous (see Section 7.4.) 0 The associated address bit is used in decoding the DRAM hit to a memory block. 1 The associated address bit is not used in the DRAM hit decode.																					
17–9	—	Reserved, should be cleared.																					
8	WP	Write protect. Determines whether the associated block of DRAM is write protected. 0 Allow write accesses 1 Ignore write accesses. The DRAM controller ignores write accesses to the memory block and an address exception occurs. Write accesses to a write-protected DRAM region are compared in the chip select module for a hit. If no hit occurs, an external bus cycle is generated. If this external bus cycle is not acknowledged, an access exception occurs.																					
7	—	Reserved, should be cleared.																					
6–1	AMx	Address modifier masks. Determine which accesses can occur in a given DRAM block. 0 Allow access type to hit in DRAM 1 Do not allow access type to hit in DRAM <table border="1" style="margin-left: 20px;"> <thead> <tr> <th>BIT</th> <th>ASSOCIATED ACCESS TYPE</th> <th>ACCESS DEFINITION</th> </tr> </thead> <tbody> <tr> <td>C/I</td> <td>CPU space/interrupt acknowledge</td> <td>MOVEC instruction or interrupt acknowledge cycle</td> </tr> <tr> <td>AM</td> <td>Alternate master</td> <td>External or DMA master</td> </tr> <tr> <td>SC</td> <td>Supervisor code</td> <td>Any supervisor-only instruction access</td> </tr> <tr> <td>SD</td> <td>Supervisor data</td> <td>Any data fetched during the instruction access</td> </tr> <tr> <td>UC</td> <td>User code</td> <td>Any user instruction</td> </tr> <tr> <td>UD</td> <td>User data</td> <td>Any user data</td> </tr> </tbody> </table>	BIT	ASSOCIATED ACCESS TYPE	ACCESS DEFINITION	C/I	CPU space/interrupt acknowledge	MOVEC instruction or interrupt acknowledge cycle	AM	Alternate master	External or DMA master	SC	Supervisor code	Any supervisor-only instruction access	SD	Supervisor data	Any data fetched during the instruction access	UC	User code	Any user instruction	UD	User data	Any user data
BIT	ASSOCIATED ACCESS TYPE	ACCESS DEFINITION																					
C/I	CPU space/interrupt acknowledge	MOVEC instruction or interrupt acknowledge cycle																					
AM	Alternate master	External or DMA master																					
SC	Supervisor code	Any supervisor-only instruction access																					
SD	Supervisor data	Any data fetched during the instruction access																					
UC	User code	Any user instruction																					
UD	User data	Any user data																					
0	V	Valid. Cleared at reset to ensure that the DRAM block is not erroneously decoded. 0 Do not decode DRAM accesses. 1 Registers controlling the DRAM block are initialized; DRAM accesses can be decoded.																					

7.3.3 GENERAL SYNCHRONOUS OPERATION GUIDELINES

To reduce system logic and to support a variety of SDRAM sizes, the DRAM controller provides SDRAM control signals as well as a multiplexed row address and column address to the SDRAM.

When SDRAM blocks are accessed, the DRAM controller can operate in either burst or continuous page mode. The following sections describe the DRAM controller interface to SDRAM, the supported bus transfers, and initialization.

7.3.3.1 ADDRESS MULTIPLEXING

Table 7-7 shows the generic address multiplexing scheme for SDRAM configurations. All possible address connection configurations can be derived from this table.

The following tables provide a more comprehensive, step-by-step way to determine the correct address line connections for interfacing the MCF5249 to SDRAM. To use the tables, find the one that corresponds to the number of column address lines on the SDRAM and to the port size as seen by the MCF5249, which is not necessarily the SDRAM port size. For example, if two 1M x 16-bit SDRAMs together form a 1M x 32-bit memory, the port size is 32 bits. Most SDRAMs likely have fewer address lines than are shown in the tables, so follow only the connections shown until all SDRAM address lines are connected.

Table 7-7 SDRAM Interface (8-Bit Port,10-Column Address Lines)

MCF5249 Pins	A17	A16	A15	A14	A13	A12	A11	A10	A9	A19	A20	A21	A22	A23
Row	17	16	15	14	13	12	11	10	9	19	20	21	22	23
Column	0	1	2	3	4	5	6	7	8	18				
SDRAM Pins	A0	A1	A2	A3	A4	A5	A6	A7	A8	A9	A10	A11	A12	A13

Table 7-8 SDRAM Interface (8-Bit Port,11-Column Address Lines)

MCF5249 Pins	A17	A16	A15	A14	A13	A12	A11	A10	A9	A19	A21	A22	A23
Row	17	16	15	14	13	12	11	10	9	19	21	22	23
Column	0	1	2	3	4	5	6	7	8	18	20		
SDRAM Pins	A0	A1	A2	A3	A4	A5	A6	A7	A8	A9	A10	A11	A12

Table 7-9 SDRAM Interface (8-Bit Port,12-Column Address Lines)

MCF5249 Pins	A17	A16	A15	A14	A13	A12	A11	A10	A9	A19	A21	A23
Row	17	16	15	14	13	12	11	10	9	19	21	23
Column	0	1	2	3	4	5	6	7	8	18	20	22
SDRAM Pins	A0	A1	A2	A3	A4	A5	A6	A7	A8	A9	A10	A11

Table 7-10 SDRAM Interface (16-Bit Port, 8-Column Address Lines)

MCF5249 Pins	A16	A15	A14	A13	A12	A11	A10	A9	A17	A18	A19	A20	A21	A22	A23
Row	16	15	14	13	12	11	10	9	17	18	19	20	21	22	23
Column	1	2	3	4	5	6	7	8							
SDRAM Pins	A0	A1	A2	A3	A4	A5	A6	A7	A8	A9	A10	A11	A12	A13	A14

Table 7-11 SDRAM Interface (16-Bit Port, 9-Column Address Lines)

MCF5249 Pins	A16	A15	A14	A13	A12	A11	A10	A9	A18	A19	A20	A21	A22	A23
Row	16	15	14	13	12	11	10	9	18	19	20	21	22	23
Column	1	2	3	4	5	6	7	8	17					
SDRAM Pins	A0	A1	A2	A3	A4	A5	A6	A7	A8	A9	A10	A11	A12	A13

Table 7-12 SDRAM Interface (16-Bit Port, 10-Column Address Lines)

Pins	A16	A15	A14	A13	A12	A11	A10	A9	A18	A20	A21	A22	A23
Row	16	15	14	13	12	11	10	9	18	20	21	22	23
Column	1	2	3	4	5	6	7	8	17	19			
SDRAM Pins	A0	A1	A2	A3	A4	A5	A6	A7	A8	A9	A10	A11	A12

Table 7-13 SDRAM Interface (16-Bit Port, 11-Column Address Lines)

Pins	A16	A15	A14	A13	A12	A11	A10	A9	A18	A20	A22	A24
Row	16	15	14	13	12	11	10	9	18	20	22	23
Column	1	2	3	4	5	6	7	8	17	19	21	
SDRAM Pins	A0	A1	A2	A3	A4	A5	A6	A7	A8	A9	A10	A11

7.3.3.2 INTERFACING EXAMPLE

The tables in the previous section can be used to configure the interface in the following example. To interface one 1M x 16-bit x 4 bank SDRAM component (8 columns) to the MCF5249, the connections would be as shown in [Table 7-14](#).

Table 7-14 SDRAM Hardware Connections

SDRAM Pins	A0	A1	A2	A3	A4	A5	A6	A7	A8	A9	A10 = CMD	A11	BA0	BA1
MCF5249 Pins	A16	A15	A14	A13	A12	A11	A10	A9	A17	A18	A19	A20	A21	A22

7.3.3.3 BURST PAGE MODE

SDRAM can efficiently provide data when an SDRAM page is opened. As soon as $\overline{\text{SDCAS}}$ is issued, the SDRAM accepts a new address and asserts $\overline{\text{SDCAS}}$ every clock for as long as accesses are in that page. In burst page mode, there are multiple read or write operations for every ACTV command in the SDRAM if the requested transfer size exceeds the port size of the associated SDRAM. The primary cycle of the transfer generates the ACTV and READ or WRITE commands; secondary cycles generate only READ or WRITE commands. As soon as the transfer completes, the PALL command is generated to prepare for the next access.

Synchronous Operation

Note: In synchronous operation, burst mode and address incrementing during burst cycles are controlled by the MCF5249 DRAM controller. Thus, instead of the SDRAM enabling its internal burst incrementing capability, the MCF5249 controls this function. This means that the burst function that is enabled in the mode register of SDRAMs must be disabled when interfacing to the MCF5249.

Figure 7-6 shows a burst read operation. In this example, $\overline{\text{DACR}}[\text{CASL}] = 01$, for an $\overline{\text{SRAS}}$ -to- $\overline{\text{SCAS}}$ delay (t_{RCD}) of 1 BCLKO cycles. Because t_{RCD} is one more than the read CAS latency ($\overline{\text{SCAS}}$ assertion to data out), this value is 2 BCLKO cycles. Notice that NOPs are executed until the last data is read. A $\overline{\text{PALL}}$ command is executed one cycle after the last data transfer.

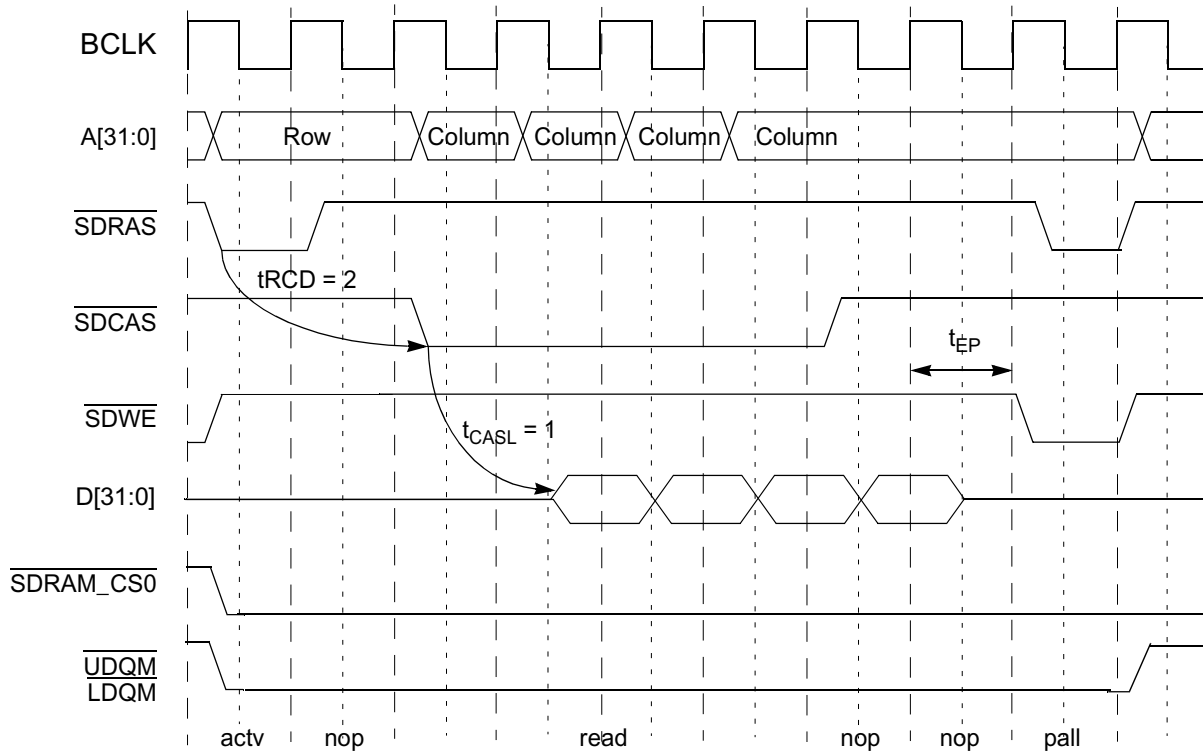

Figure 7-6 Burst Read SDRAM Access

Figure 7-7 shows the burst write operation. In this example, $\overline{\text{DACR}}[\text{CASL}] = 01$, which creates an $\overline{\text{SRAS}}$ -to- $\overline{\text{SCAS}}$ delay (t_{RCD}) of 2 BCLKO cycles.

Note: Data is available upon $\overline{\text{SCAS}}$ assertion and a burst write cycle completes two cycles sooner than a burst read cycle with the same t_{RCD} . The next bus cycle is initiated sooner, but cannot begin an SDRAM cycle until the precharge-to-ACTV delay completes.

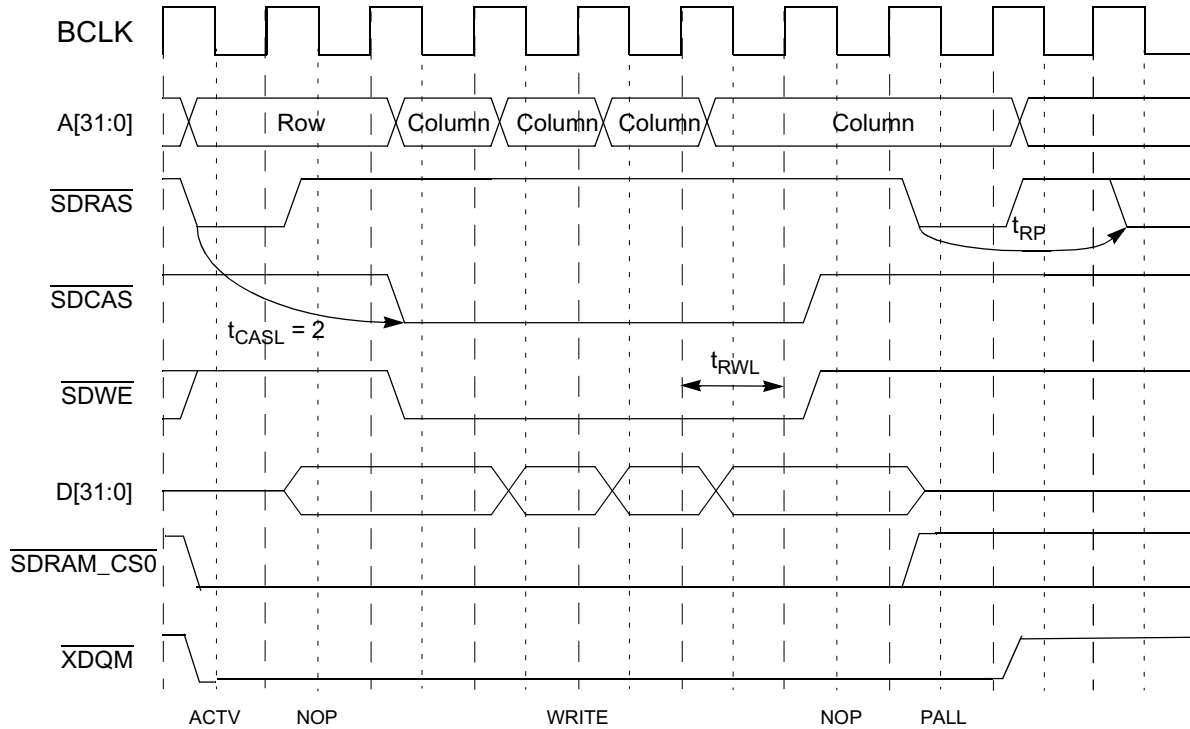

Figure 7-7 Burst Write SDRAM Access

Accesses in synchronous burst page mode always cause the following sequence:

1. ACTV command
2. NOP commands to assure \overline{SRAS} -to- \overline{SCAS} delay (if \overline{CAS} latency is 1, there are no NOP commands).
3. Required number of READ or WRITE commands to service the transfer size with the given port size.
4. Some transfers need more NOP commands to assure the ACTV-to-precharge delay.
5. PALL command
6. Required number of idle clocks inserted to assure precharge-to-ACTV delay.

7.3.3.4 CONTINUOUS PAGE MODE

Continuous page mode is identical to burst page mode, except that it allows the processor core to handle successive bus cycles that hit the same page without having to close the page. When the current bus cycle finishes, the MCF5249 core internal pipelined bus can predict whether the upcoming cycle will hit in the same page.

- If the next bus cycle is not pending or misses in the page, the PALL command is generated to the SDRAM.
- If the next bus cycle is pending and hits in the page, the page is left open, and the next SDRAM access begins with a READ or WRITE command.
- Because of the nature of the internal CPU pipeline this condition does not occur often; however, the use of continuous page mode is recommended because it can provide a slight performance increase.

Figure 7-8 shows two read accesses in continuous page mode.

Synchronous Operation

Note: There is no precharge between the two accesses. Also, the second cycle begins with a read operation with no ACTV command.

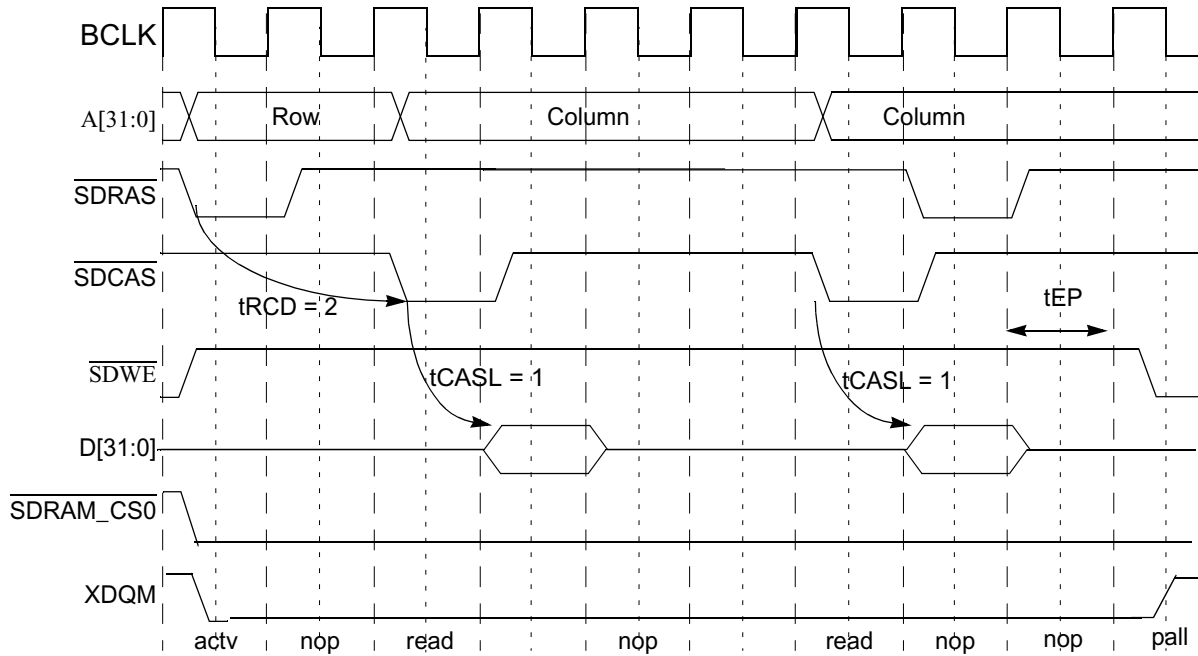

Figure 7-8 Synchronous, Continuous Page-Mode Access—Consecutive Reads

Figure 7-9 shows a write followed by a read in continuous page mode. Because the bus cycle is terminated with a WRITE command, the second cycle begins sooner after the write than after the read. A read requires data to be returned before the bus cycle can terminate.

Note: In continuous page mode, secondary accesses output the column address only.

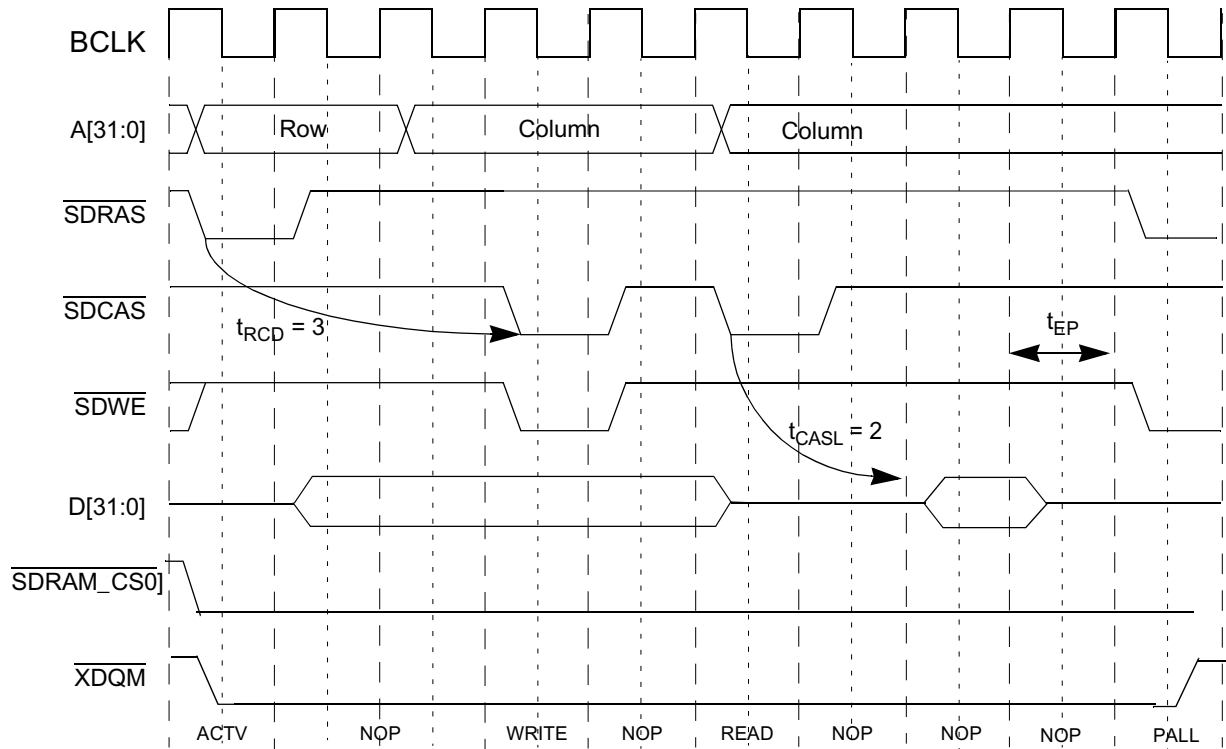

Figure 7-9 Synchronous, Continuous Page-Mode Access—Read after Write

7.3.3.5 AUTO-REFRESH OPERATION

The DRAM controller is equipped with a refresh counter and control. This logic is responsible for providing timing and control to refresh the SDRAM. Once the refresh counter is set, and refresh is enabled, the counter counts to zero. At this time, an internal refresh request flag is set and the counter begins counting down again. The DRAM controller completes any active burst operation and then performs a PALL operation. The DRAM controller then initiates a refresh cycle and clears the refresh request flag. This refresh cycle includes a delay from any precharge to the auto-refresh command, the auto-refresh command, and then a delay until any ACTV command is allowed. Any SDRAM access initiated during the auto-refresh cycle is delayed until the cycle is completed.

Figure 7-10 shows the auto-refresh timing. In this case, there is an SDRAM access when the refresh request becomes active. The request is delayed by the precharge to ACTV delay programmed into the active SDRAM bank by the CAS bits. The REF command is then generated and the delay required by DCR[RTIM] is inserted before the next ACTV command is generated. In this example, the next bus cycle is initiated, but does not generate an SDRAM access until T_{RC} is finished. Because both chip selects are active during the REF command, it is passed to both blocks of external SDRAM.

Synchronous Operation

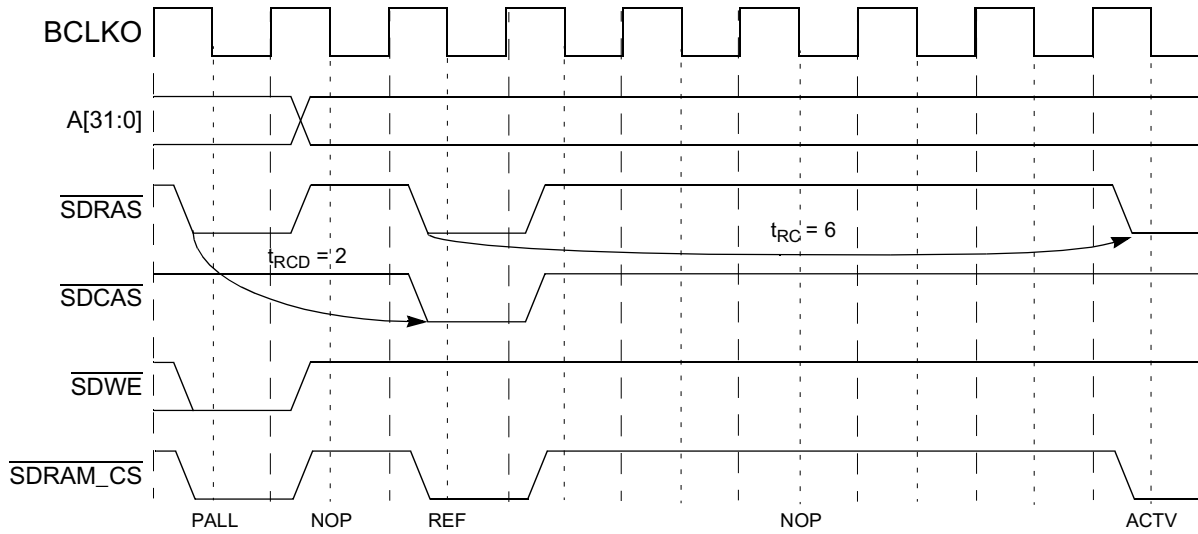

Figure 7-10 Auto-Refresh Operation

7.3.3.6 SELF-REFRESH OPERATION

Self-refresh is a method of allowing the SDRAM to enter into a low-power state, while at the same time to perform an internal refresh operation and to maintain the integrity of the data stored in the SDRAM. The DRAM controller supports self-refresh with DCR[IS]. When IS is set, the SELF command is sent to the SDRAM. When IS is cleared, the SELFX command is sent to the DRAM controller. Figure 7-11 shows the self-refresh operation.

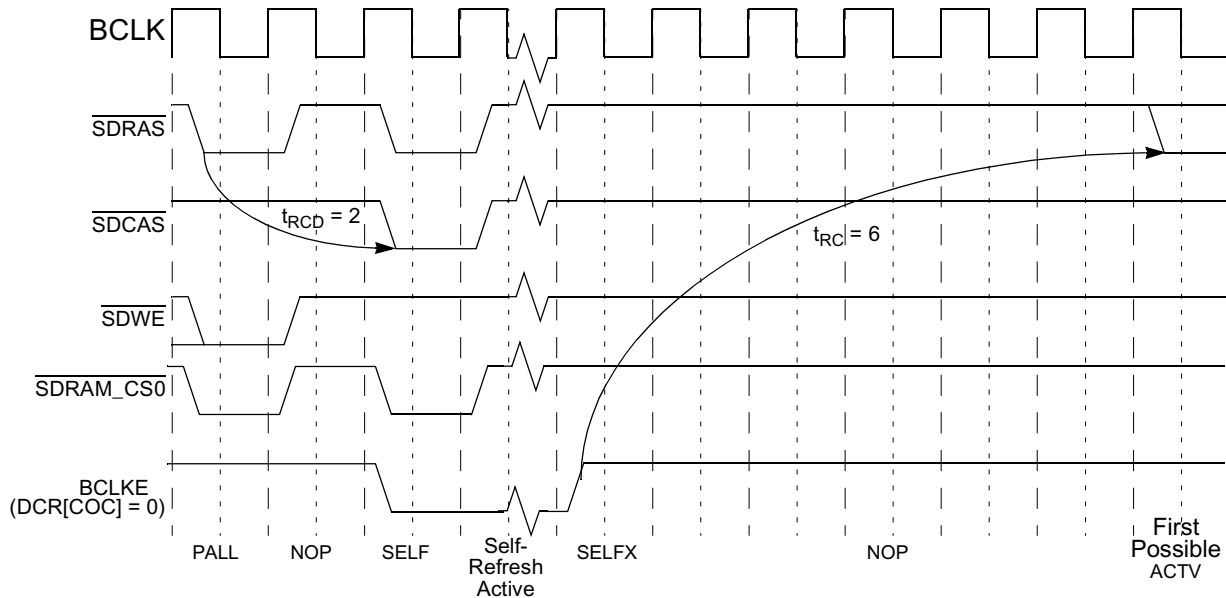

Figure 7-11 Self-Refresh Operation

7.3.4 INITIALIZATION SEQUENCE

Synchronous DRAMs have a prescribed initialization sequence. The DRAM controller supports this sequence with the following procedure:

1. SDRAM control signals are reset to idle state. Wait the prescribed period after reset before any action is taken on the SDRAMs. This is normally around 100 μ s.
2. Initialize the DCR, DACR, and DMR in their operational configuration. Do not yet enable PALL or REF commands.
3. Issue a PALL command to the SDRAMs by setting DCR[IP] and accessing a SDRAM location. Wait the time (determined by t_{RP}) before any other execution.
4. Enable refresh (set DACR[RE]) and wait for at least 8 refreshes to occur.
5. Before issuing the MRS command, determine if the DMR mask bits need to be modified to allow the MRS to execute properly
6. Issue the MRS command by setting DACR[IMRS] and accessing a location in the SDRAM.

Note: Mode register settings are driven on the SDRAM address bus, so care must be taken to change DMR[BAM] if the mode register configuration does not fall in the address range determined by the address mask bits. After the mode register is set, DMR mask bits can be restored to their desired configuration.

7.3.4.1 MODE REGISTER SETTINGS

It is possible to configure the operation of SDRAMs, namely their burst operation and $\overline{\text{CAS}}$ latency, through the SDRAM component's mode register. $\overline{\text{CAS}}$ latency is a function of the speed of the SDRAM and the bus clock of the DRAM controller. The DRAM controller operates at a $\overline{\text{CAS}}$ latency of 1 or 2.

Although the MCF5249 DRAM controller supports bursting operations, it does not use the bursting features of the SDRAMs. Because the MCF5249 can burst operand sizes of 1, 2, 4, or 16 bytes long, the concept of a fixed burst length in the SDRAMs mode register becomes problematic. Therefore, the MCF5249 DRAM controller generates the burst cycles rather than the SDRAM device. Because the MCF5249 generates a new address and a READ or WRITE command for each transfer within the burst, the SDRAM mode register should be set either to a burst length of one or to not burst. This allows bursting to be controlled by the MCF5249 instead.

The SDRAM mode register is written by setting the associated block's DACR[IMRS]. First, the base address and mask registers must be set to the appropriate configuration to allow the mode register to be set.

Note: Improperly set DMR mask bits may prevent access to the mode register address. Thus, the user should determine the mapping of the mode register address to the MCF5249 address bits to find out if an access is blocked. If the DMR setting prohibits mode register access, the DMR should be reconfigured to enable the access and then set to its necessary configuration after the MRS command executes.

The associated CBM bits should also be initialized. After DACR[IMRS] is set, the next access to the SDRAM address space generates the MRS command to that SDRAM. The address of the access should be selected to place the correct mode information on the SDRAM address pins. The address is not multiplexed for the MRS command. The MRS access can be a read or write. The important thing is that the address output of that access needs the correct mode programming information on the correct address bits.

Figure 7-12 shows the MRS command, which occurs in the first clock of the bus cycle.

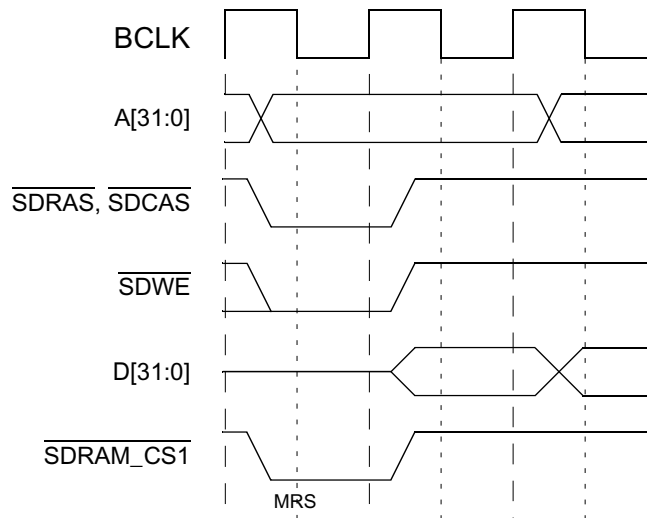

Figure 7-12 Mode Register Set (MRS) Command

7.4 SDRAM EXAMPLE

This example interfaces a Samsung k4s641633 1M x 16-bit x 4 bank SDRAM component to a MCF5249 operating at 40 MHz (20 Mhz bus). [Table 7-15](#) lists design specifications for this example.

Table 7-15 SDRAM Example Specifications

PARAMETER	SPECIFICATION
12 rows, 8 columns	
Two bank-select lines to access four internal banks	
ACTV-to-read/write delay (t_{RCD})	20 nS (min.)
Period between auto refresh and ACTV command (t_{RC})	70 nS
ACTV command to precharge command (t_{RAS})	48 nS (min.)
Precharge command to ACTV command (t_{RP})	20 nS (min.)
Last data input to PALL command (t_{RWL})	1 bus clock (25 nS)
Auto refresh period for 4096 rows (t_{REF})	64 mS

7.4.1 SDRAM INTERFACE CONFIGURATION

To interface this component to the MCF5249 DRAM controller, use the connection table that corresponds to a 16-bit port size with 8 columns ([Figure 7-14](#)). Two pins select one of four banks when the part is functional. [Table 7-16](#) shows the proper hardware hook-up.

Table 7-16 SDRAM Hardware Connections

MCF5249 Pins	A16	A15	A14	A13	A12	A11	A10	A9	A17	A18	A19	A20	A21	A22
SDRAM Pins	A0	A1	A2	A3	A4	A5	A6	A7	A8	A9	A10 = CMD	A11	BA0	BA1

7.4.2 DCR INITIALIZATION

At power-up, the DCR has the following configuration if synchronous operation and SDRAM address multiplexing is desired.

	15	14	13	12	11	10	9	8							0	
Field	SO	res	NAM	COC	IS	RTIM		RC								
Setting	1	X	0	0	0	0	0	0	0	0	0	1	0	0	1	0
(hex)	8			0				1			2					

Figure 7-13 Initialization Values for DCR

This configuration results in a value of 0x8012 for DCR, as shown in [Table 7-17](#).

Table 7-17 DCR Initialization Values

BITS	NAME	SETTING	DESCRIPTION
15	SO	1	Indicating synchronous operation
14	—	x	Don't care (reserved)
13	NAM	0	Indicating SDRAM controller multiplexes address lines internally
12	COC	0	SCKE is used as clock enable instead of command bit because user is not multiplexing address lines externally and requires external command feed.
11	IS	0	At power-up, allowing power self-refresh state is not appropriate because registers are being set up.
10–9	RTIM	00	Because t_{RC} value is 70 nS, indicating a 3-clock refresh-to-ACTV timing.
8–0	RC	0x12	Specification indicates auto-refresh period for 4096 rows to be 64 mS or refresh every 15.625 μ s for each row, or 312 bus clocks at 20MHz. Because DCR[RC] is incremented by 1 and multiplied by 16, $RC = (312 \text{ bus clocks}/16) - 1 = 18.56 = 0x12$

7.4.3 DACR INITIALIZATION

As shown in [Figure 7-14](#), in this example the SDRAM is programmed to access only the second 512-Kbyte block of each 1-Mbyte partition in the SDRAM (each 16 Mbytes). The starting address of the SDRAM is 0xFF80_0000. Continuous page mode feature is used.

SDRAM Example

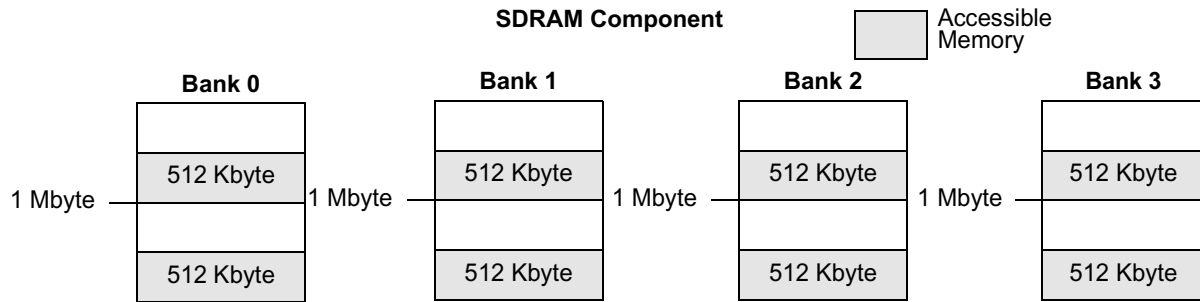

Figure 7-14 SDRAM Configuration

The DACRs should be programmed as shown in Figure 7-15.

	31															18		17	16
Field	BA																	—	
Setting	1111_1111_1000_10																	xx	
(hex)	15					15					8			8					
	15	14	13	12	11	10	8	7	6	5	4	3	2	1	0				
Field	RE	—	CASL	—	CBM		—	IMRS	PS		IP	PM	—						
Setting	0	X	01	X	010		X	0	10		0	1	xx						
(hex)	1			2				2			4								

Figure 7-15 DACR Register Configuration

This configuration results in a value of DACR0 = 0xFF88_1224, as described in Table 7-18. DACR1 initialization is not needed because there is only one block. Subsequently, DACR1[RE,IMRS,IP] should be cleared; everything else is a don't care.

Table 7-18 DACR Initialization Values

BITS	NAME	SETTING	DESCRIPTION
31–18	BA		Base address. So DACR0[31–16] = 0xFF88, which places the starting address of the SDRAM accessible memory at 0xFF88_0000.
17–16	—		Reserved. Don't care.
15	RE	0	0, which keeps auto-refresh disabled because registers are being set up at this time.
14	—		Reserved. Don't care.
13–12	CASL	01	Indicates a delay of data 1 cycle after $\overline{\text{CAS}}$ is asserted
11	—		Reserved. Don't care.
10–8	CBM	010	Command bit is pin 19 and bank selects are 20 and up.
7	—		Reserved. Don't care.
6	IMRS	0	Indicates MRS command has not been initiated.
5–4	PS	10	16-bit port.

Table 7-18 DACR Initialization Values (Continued)

BITS	NAME	SETTING	DESCRIPTION
3	IP	0	Indicates precharge has not been initiated.
2	PM	1	Indicates continuous page mode
1-0	—		Reserved. Don't care.

7.4.4 DMR INITIALIZATION

In this example, again, only the second 512-Kbyte block of each 1-Mbyte space is accessed in each bank. In addition the SDRAM component is mapped only to readable and writable supervisor and user data. The DMRs have the following configuration.

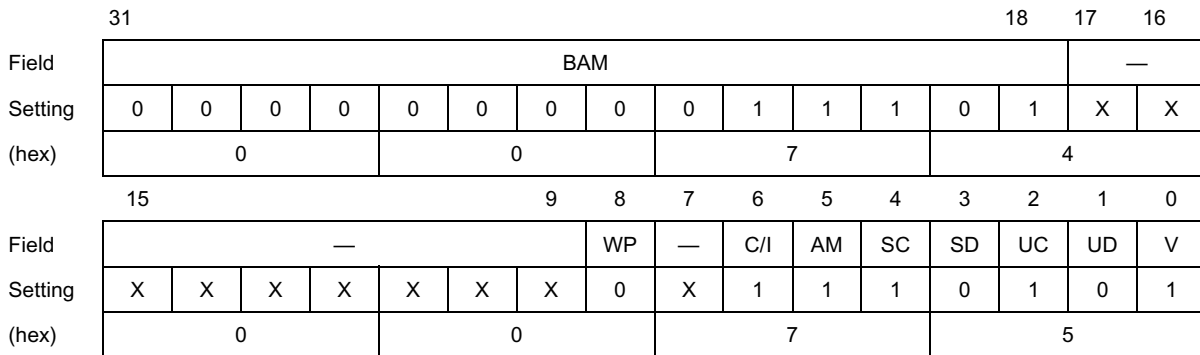

Figure 7-16 DMR0 Register

With this configuration, the DMR0 = 0x0074_0075, as described in Table 7-19.

Table 7-19 DMR0 Initialization Values

BITS	NAME	SETTING	DESCRIPTION
31-16	BAMB		With bits 17 and 16 as don't cares, BAMB = 0x0074, which leaves bank select bits and upper 512K select bits unmasked. Bits 22 and 21 are set because they are used as bank selects; bit 20 is set because it controls the 1-Mbyte boundary address.
15-9	—		Reserved. Don't care.
8	WP	0	Allow reads and writes
7	—		Reserved
6	C/I	1	Disable CPU space access
5	AM	1	Disable alternate master access
4	SC	1	Disable supervisor code accesses
3	SD	0	Enable supervisor data accesses
2	UC	1	Disable user code accesses
1	UD	0	Enable user data accesses
0	V	1	Enable accesses.

7.4.5 MODE REGISTER INITIALIZATION

When DACR[IMRS] is set, a bus cycle initializes the mode register. If the mode register setting is read on A[9:0] of the SDRAM on the first bus cycle, the bit settings on the corresponding MCF5249 address pins must be determined while being aware of masking requirements.

Table 7-20 lists the desired initialization setting:

Table 7-20 Mode Register Initialization

MCF5249 Pins	SDRAM Pins	Mode Register Initialization	
A22	BA1		0
A21	BA0		0
A20	A11	Reserved	0
A19	command	WB	0
A18	A9	Opmode	0
A17	A8	Opmode	0
A9	A7		
A10	A6	CASL	0
A11	A5	CASL	0
A12	A4	CASL	1
A13	A3	BT	0
A14	A2	BL	0
A15	A1	BL	0
A16	A0	BL	0

Next, this information is mapped to an address to determine the hexadecimal value.

	31	30	29	28	27	26	25	24	23	22	21	20	19	18	17	16
Field																
Setting	X	X	X	X	X	X	X	X	X	0	0	0	0	0	0	0
(hex)	0			0				0				0				
	15	14	13	12	11	10	9	8	7	6	5	4	3	2	1	0
Field																V
Setting	0	0	0	1	0	0	0	X	X	X	X	X	X	X	X	X
(hex)	1			0				0				0				

Figure 7-17 Mode Register Mapping to MCF5249 A[31:0]

Although A[31:20] corresponds to the address programmed in DACR0, according to how DACR0 and DMR0 are initialized, bit 19 must be set to hit in the SDRAM. Thus, before the mode register bit is set, DMR0[19] must be set to enable masking.

7.4.6 INITIALIZATION CODE

The following assembly code initializes the SDRAM example.

Power-Up Sequence:

```

move.w    #0x8012, d0//Initialize DCR
move.w    d0, DCR
move.l    #0xFF881220, d0 //Initialize DACR0
move.l    d0, DACR0
move.l    #0x00740075, d0//Initialize DMR0
move.l    d0, DMR0

```

Precharge Sequence:

```

move.l    #0xFF881228, d0//Set DACR0[IP]
move.l    d0, DACR0
move.l    #0xBEADDEED, d0//Write to memory location to init. precharge
move.l    d0, 0xFF880000

```

Refresh Sequence:

```

move.l    #0xFF889220, d0//Enable refresh bit in DACR0
move.l    d0, DACR0

```

Mode Register Initialization Sequence:

```

move.l    #0x00600075, d0//Mask bit 19 of address
move.l    d0, DMR0
move.l    #0xFF889260, d0//Enable DACR0[IMRS]; DACR0[RE] remains set
move.l    d0, DACR0
move.l    #0x00000000, d0//Access SDRAM address to initialize mode register
move.l    d0, 0xFF801000
move.l    #0x00740075, d0//Set up DMR again
move.l    d0, DMR0

```

NOTES

Section 8

Bus Operation

This section describes bus functionality, the bus control signals, and the bus cycles provided for data-transfer operations. Bus operation is defined for transfers initiated by the MCF5249 as a bus master and for transfers initiated by an alternate bus master. This section includes descriptions of the error conditions, bus arbitration, and the reset operation.

8.1 BUS FEATURES

- 23 bit address bus
- 16 bit data bus
- 16 bit port size
- Generates byte, word, longword, and line size transfers
- Burst and burst-inhibited transfer support
- Internal termination generation

8.2 BUS AND CONTROL SIGNALS

Although the timing of all of these signals is referenced to the BCLK, it is not considered a bus signal. It is expected that the clock will be routed as needed to meet application requirements. [Table 8-1](#) summarizes the MCF5249 bus signals. A brief description of the function of each signal follows.

Note:An overbar indicates an active-low signal.

Table 8-1 MCF5249 Bus Signal Summary

SIGNAL NAME	DIRECTION	DESCRIPTION
A[23:1]	Out	Address Bus
\overline{RW} /GPIO9	Out	Read-write control
D[31:16]	In/Out	Data Bus
CS0	Out	Chip select 0
$\overline{CS1}$ /GPIO1	Out	Chip select 1/gpio
\overline{OE} /GPO40	Out	Output enable

8.2.1 ADDRESS BUS

The address bus A[23:1] provides the address of the byte or most significant byte of the word or longword being transferred. The address lines also serve as the DRAM address pins, providing multiplexed row and column address signals.

A0 is not available on the address bus. As a result, the MCF5249 supports only 16-bit port size.

8.2.2 READ/WRITE CONTROL

The read/write control line is shared with GPIO9. The power-on reset function of \overline{RW} /GPIO9 is \overline{RW} . This function can be programmed in the GPIO-FUNCTION register. See [Section 9.8](#) for details.

When function is \overline{RW} , pin will indicate if bus cycle in progress is read or write. \overline{RW} timing is same as address timing.

8.2.3 TRANSFER ACKNOWLEDGE (TA)

This active-low synchronous input signal indicates the successful completion of a requested data transfer operation. During MCF5249-initiated transfers, transfer acknowledge (TA) is an asynchronous input signal from the referenced slave device indicating completion of the transfer.

The MCF5272 edge-detects and retimes the TA input. This means that an additional wait state may or may not be inserted. For example if the active chip select is used to immediately generate the TA input, one or two wait states may be inserted in the bus access.

The TA signal function is not available after reset. It must be enabled by configuring the appropriate pin configuration register bits along with the value of CSORn[WS]. If TA is not used, it should either have a pullup resistor or be driven through gating logic that always ensures the input is inactive. TA should be negated on the negating edge of the active chip select.

TA must always be negated before it can be recognized as asserted again. If held asserted into the following bus cycle, it has no effect and does not terminate the bus cycle.

Note:For the MCF5249 to accept the transfer as successful with a transfer acknowledge, TEA must be negated throughout the transfer.

TA is not used for termination during SDRAM accesses.

8.2.4 DATA BUS

The data bus D[31:16] is a bidirectional, non-multiplexed bus. Data is latched by the MCF5249 on the rising BCLK clock edge. When interfacing with external memory or peripherals, the data bus port width, wait states, and internal termination are initially defined.

Table 8-2 Reset Port Settings

RESET PORT SIZE	16 BIT
Reset cycle length	Internal termination, 15 wait cycles

The port width for each chip-select and DRAM bank are user programmable. If none of the chip-selects, DRAM bank or SBC spaces match the address decode, the memory cycle will terminate with error. The

data bus can transfer byte or word-sized data. All 16 bits of the data bus are driven during writes, regardless of port width or operand size.

Processor External Data Bus	D[31:24]	D[23:16]
	↓	↓
16-Bit Port Memory	Byte 0	Byte 1
	Byte 2	Byte 3
	↓	
8-Bit Port Memory	Byte 0	
Driver with Indeterminate Values	Byte 1	
	Byte 2	
	Byte 3	

Figure 8-1 Connections for External Memory Port Sizes

8.2.5 CHIP SELECTS

Chip select $\overline{CS1}$ is shared with GPIO1 and chip select $\overline{CS0}$ is not. Power-on reset function of $\overline{CS1}$ /GPIO1 is $\overline{CS1}$. The function can be programmed in the GPIO-FUNCTION register. See [Section 9.8](#) for details.

When the address decode matches one of the chip select spaces, the MCF5249 processor will pull low one of the chip selects to indicate external device access on its bus.

There are also two dedicated chip selects (CS2 and CS3) used for the IDE and/or SmartMedia interface.

8.2.6 OUTPUT ENABLE

Output enable \overline{OE} is shared with GPO40. Power-on reset function of \overline{OE} /GPO40 is \overline{OE} . The function can be programmed in the GPIO1-function register. See [Section 9.8](#) on gpios for details.

When function is \overline{OE} , the MCF5249 will pull this pin low during any read cycle from a device selected by $\overline{CS0}$, $\overline{CS1}$, CS2 or CS3.

8.3 CLOCK AND RESET SIGNALS

These signals provide the external system interface for the MCF5249 (see [Table 8-2](#)).

Table 8-3 CF-Bus Signal Summary

SIGNAL NAME	DIRECTION	DESCRIPTION
RSTI	In	Reset In
BCLK	Out	System Bus Clock Output

8.3.1 RESET IN

Asserting $\overline{\text{RSTI}}$ causes the MCF5249 processor to enter reset exception processing. When $\overline{\text{RSTI}}$ is recognized, the data bus is tri-stated, and $\overline{\text{OE}}$, $\overline{\text{CS0}}$, and $\overline{\text{CS1}}$ are negated. Refer to [Section 8.7 Reset Operation](#).

8.3.2 SYSTEM BUS CLOCK OUTPUT

The BCLK output signal is generated by the internal PLL, and is the system bus clock output used as the bus timing reference by the external devices. BCLK is always half the frequency of the processor clock.

8.4 BUS CHARACTERISTICS

The external bus operates at the same speed as the bus clock rate, where all bus operations are synchronous to the rising edge of BCLK, and the bus control signal $\overline{\text{CS}}$ are synchronous to the falling edge of the BCLK, which is shown in [Figure 8-2](#). The bus characteristics may be somewhat different for interfacing with external DRAM.

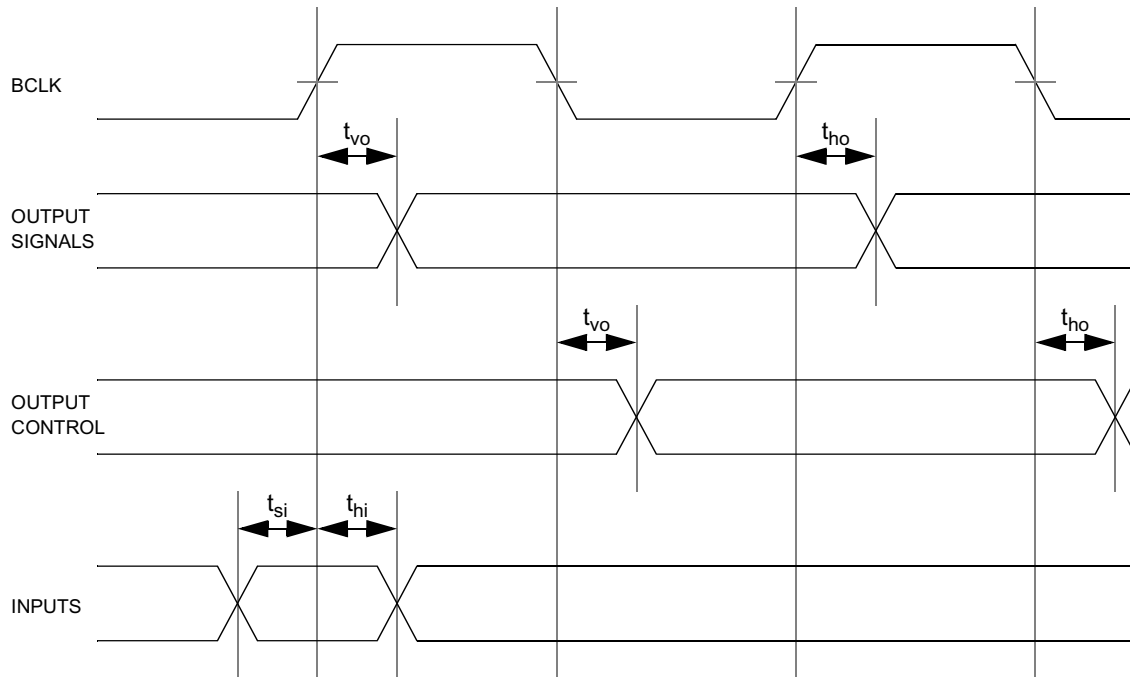

t_{vo} = Propagation delay of signal relative to BCLK edge
 t_{ho} = Output hold time relative to BCLK edge
 t_{si} = Required input setup time relative to BCLK edge
 t_{hi} = Required input hold time relative to BCLK edge

Figure 8-2 Signal Relationship to BCLK for Non-DRAM Access

8.5 DATA TRANSFER OPERATION

Data transfer between the MCF5249 processor and other devices involves the following four signals:

1. Address bus (A[23:1])
2. \overline{RW} control signal
3. Data bus (D[31:16])
4. Strobe signal ($\overline{CS0}$, $\overline{CS1}$, \overline{OE})

The address bus, write data, and all attribute signals make transition on the rising edge of BCLK. The strobe signals $\overline{CS0}$, $\overline{CS1}$, \overline{OE} make its transition on the falling edge of BCLK. Read data is latched into the MCF5249 on the rising edge of BCLK.

The MCF5249 bus supports byte, word, and longword operand transfers and uses a 16-bit data port. With the MCF5249, the port size of all memory must be programmed to 16 bits, the internal transfer termination must be enabled, and the number of wait states must be set for the external slave being accessed by programming the Chip-Select Control Registers (CSCRs) and the DRAM Controller Control Registers (DCRs).

Figure 8-1 shows the byte lanes that external chip-select memory and DRAM should be connected to and the sequential transfers that would occur for each memory if a longword was transferred to it. A 16-bit

memory should be connected to [31:16] of the MCF5249 data bus. For a longword transfer, the most significant word D[31:16] will be transferred on lane D[31:16], followed by the least significant word being transferred.

8.5.1 BUS CYCLE EXECUTION

When a bus cycle is initiated, the MCF5249 processor compares the address of that bus cycle with the base address and mask configurations programmed for various memory-mapped peripherals. These include SRAM0, SRAM1, System Bus Controller 1 and 2, chip selects 0 and 1 and DRAM block 0 and 1. If no match is found, the cycle will terminate in error. If a match is found for chip select 0 and 1, or DRAM block 0 and 1, the bus cycle will be executed on the external bus. Chip select accesses follow timing diagrams given in this section. DRAM accesses are different. They are described in the section on the DRAM controller.

Figure 8-4 shows the type of access as a function of match in various memory space programming registers.

Table 8-4 Accesses by Matches

KRAM MATCHES	SBC 2 MATCHES	SBC 1 MATCHES	NUMBER OF CHIP SELECTS REGISTER MATCHES	NUMBER OF DRAM CONTROLLE R REGISTER MATCHES	TYPE OF ACCESS
yes	any	any	any	any	on-chip SRAM
no	yes	any	any	any	SBC 2
no	no	yes	none	none	SBC 0
no	no	no	single	none	As defined by Chip-Select control register
no	no	no	none	single	As defined by DRAM control register
no	no	no	None	None	Undefined
All other combinations					Undefined

Basic operation of the MCF5249 bus is a three-clock bus cycle. During the first clock, the address is driven. CS_x is asserted at the falling edge of the clock to indicate that address and attributes are valid and stable. Data and \overline{TA} are sampled during the second clock of a bus-read cycle. \overline{TA} is generated internally in the chip select module.

During a read, the external device provides data and is sampled at the rising edge at the end of the second bus clock. This data is concurrent with \overline{TA} , which is also sampled at the rising edge of the clock. During a write, the MCF5249 drives data from the rising clock edge at the end of the first clock to the rising clock edge at the end of the bus cycle.

Users can add wait states between the first and second clocks by delaying the assertion of \overline{TA} . This refers to internal transfers only and not the write cycles. This is done by programming the relevant chip select

registers. If "0000" is programmed in the WS field of the relevant chip select register, a no wait cycle results. If n is programmed in the WS field, n wait cycles will result. The last clock of the bus cycle uses what would be an idle clock between cycles to provide hold time for address and write data. Figure 8-4 and Figure 8-6 show the basic read and write operations.

8.5.2 READ CYCLE

The Read cycle as shown in Figure 8-4, will occur if the wait cycle field (WS) in the Chip Select Control Register (CSR) is programmed to value "0000". The CS low time is increased with n clocks if n is programmed into the WS field.

During a read cycle, the MCF5249 receives data from memory or from a peripheral device. The read cycle flowchart is shown in Figure 8-3 while the read cycle timing diagram is shown in Figure 8-4.

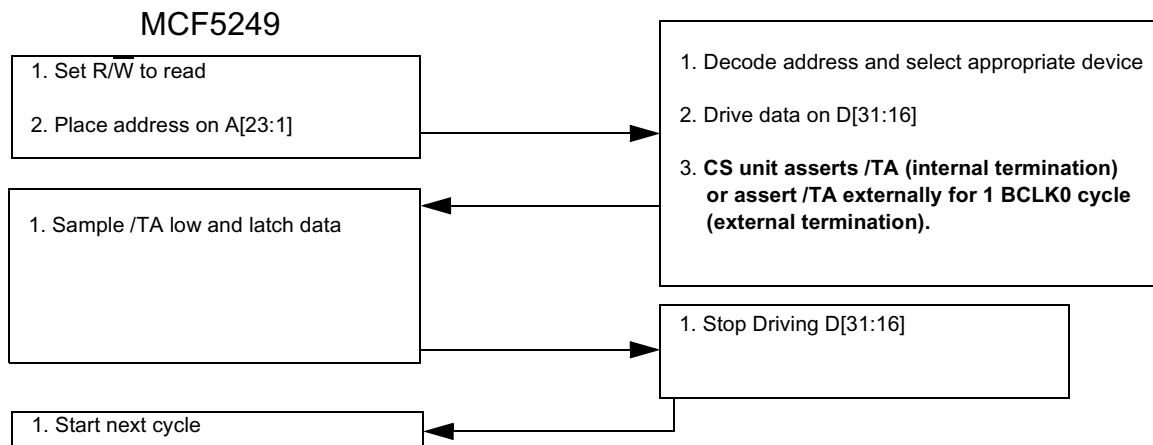

Figure 8-3 Read Cycle Flowchart

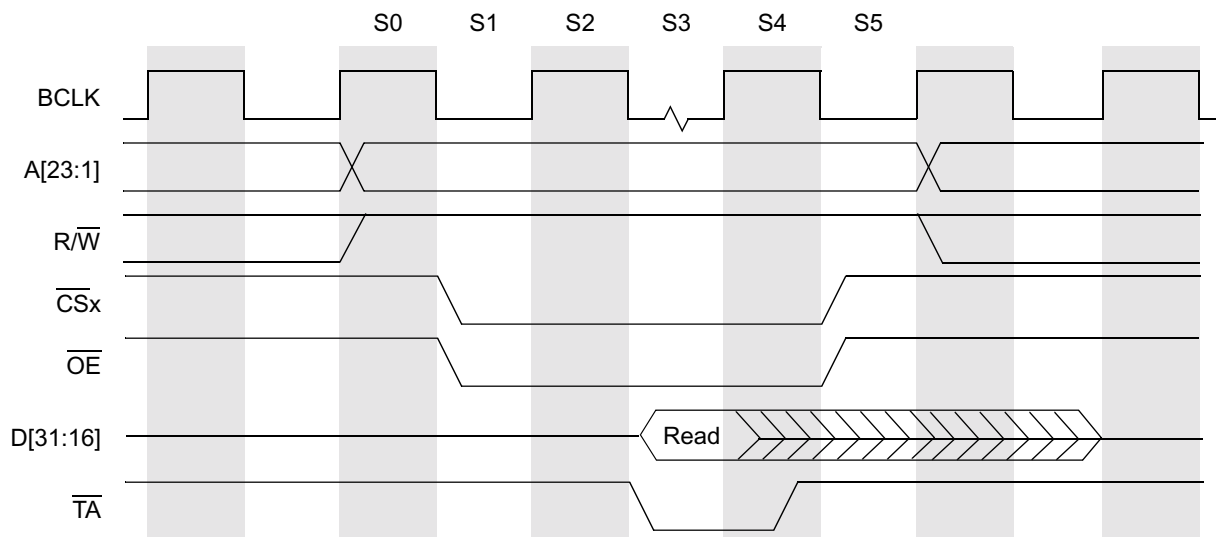

Figure 8-4 Basic Read Bus Cycle

A basic read bus cycle has six states (S0–S5). The signal timing relationship in the constituent states of a basic read cycle is as follows:

Table 8-5 Read Cycle States

STATE NAME	DESCRIPTION
STATE 0	The read cycle is initiated in state 0 (S0). On the rising edge of BCLK, the MCF5249 places a valid address on the address bus and drives R/W high, if it is not already high.
STATE 1	The appropriate \overline{CS} and \overline{OE} are asserted on the falling edge of BCLK.
STATE 2	
STATE 3	Data is made available by the external device and is sampled on the rising edge of BCLK with /TA asserted. If /TA not asserted before the rising edge of BCLK at the end of the first clock cycle, the MCF5249 inserts wait states (full clock cycles) until /TA is asserted. If internal /TA is requested (auto-acknowledge enabled in the chip select control register, CSCR) then /TA is generated internally by the chip select module.
STATE 4	During state 4, /TA should be negated by the external device or if auto-acknowledge is enabled, negated internally by the chip select module.
STATE 5	\overline{CS} and \overline{OE} are negated on the falling edge of state 5 (S5). The MCF5249 stops driving the address lines and R/W on the rising edge of BCLK, terminating the read cycle. The external device must have its drive from the bus...! with 'The external device must stop driving the bus. The rising edge of BCLK may be the start of state 0 for the next access cycle.
<p>Note: The external device has a maximum of 1.5 BCLK cycles after the start of S4 to three-state the data bus after data is sampled in S3 during a read cycle. This applies to basic read cycles and the last transfer of a burst.</p> <p>Note: The MCF5249 would not drive out data for a minimum of two BCLK cycles. However, another slave device may start driving the bus as soon as its chip select is asserted. Chip select may be asserted at the beginning of S1, so bus drive must stop before the end of S0. Under these conditions, data contention on the bus would not exist.</p>	

8.5.3 WRITE CYCLE

The Write cycle as shown in [Figure 8-6](#), will occur if the wait cycle field (WS) in the Chip Select Control Register (CSR) is programmed to value "0000". The CS low time is increased with n clocks if n is programmed into the WS field.

During a write cycle, the MCF5249 sends data to the memory or to a peripheral device.

The write cycle flowchart is shown in the following figure, while the write cycle timing diagram is shown in [Figure 8-6](#).

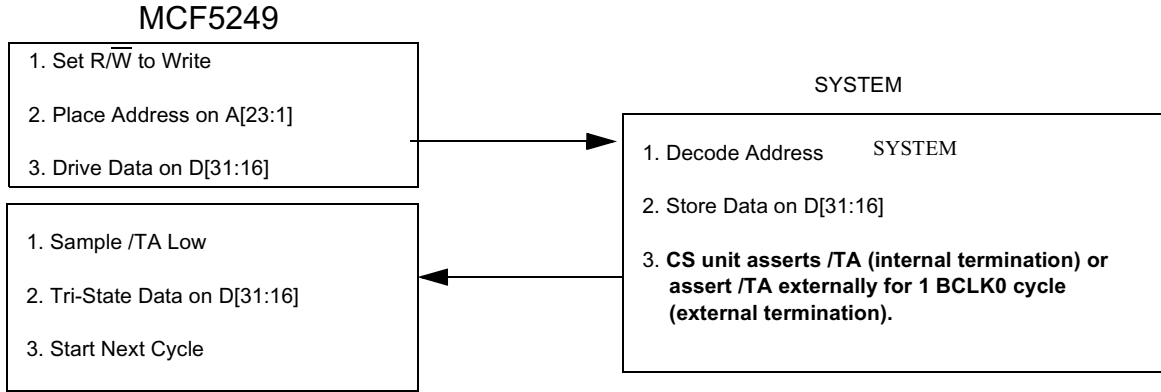

Figure 8-5 Write Cycle Flowchart

The description for the six states of a basic write cycle is as follows:

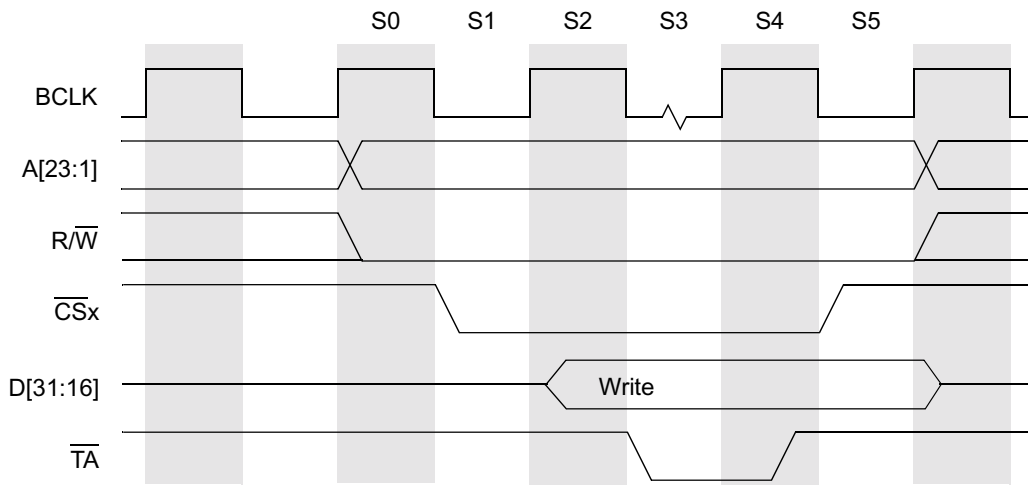

Figure 8-6 Basic Write Bus Cycle

Table 8-6 Write Cycle States

STATE NAME	DESCRIPTION
STATE 0	The write cycle is initiated in state 0 (S0). On the rising edge of BCLK, the MCF5249 places a valid address on the address bus and drives R/\overline{W} low, if it is not already low.
STATE 1	The appropriate \overline{CS} is asserted on the falling edge of BCLK.
STATE 2	The data bus is driven out of high impedance as data is placed on the bus on the rising edge of BCLK.

Table 8-6 Write Cycle States (Continued)

STATE NAME	DESCRIPTION
STATE 3	During state 3 (S3), the MCF5249 waits for a cycle termination signal (\overline{TA}). If \overline{TA} is not asserted before the rising edge of BCLK at the end of the first clock cycle, the MCF5249 inserts wait states (full clock cycles) until \overline{TA} is asserted. \overline{TA} is generated internally by the chip select module. If internal \overline{TA} is requested (auto-acknowledge enabled in the chip select control register, CSCR) then \overline{TA} is generated internally by the chip select module.
STATE 4	During state 4, \overline{TA} should be negated by the external device or if auto-acknowledge is enabled, negated internally by the chip select module.
STATE 5	\overline{CS} is negated on the falling edge of BCLK in state 5 (S5). The MCF5249 stops driving the address lines and R/\overline{W} , terminating the write cycle. The data bus returns to high impedance on the rising edge of BCLK. The rising edge of BCLK may be the start of state 0 for the next access cycle.

8.5.4 BACK-TO-BACK BUS CYCLES

The MCF5249 can accommodate back-to-back bus cycles. The processor runs back-to-back bus cycles whenever possible. For example, when a longword read is started on a word-size bus, and burst read enable is disabled into the relevant chip select register, the processor will perform two word reads back to back. Figure 7-9 shows a read, followed by a write that occurs back to back.

A basic read and a write cycle are used to illustrate the back-to-back cycle. There is no restriction as to the type of operation to be placed back to back. The initiation of a back-to-back cycle is not user definable.

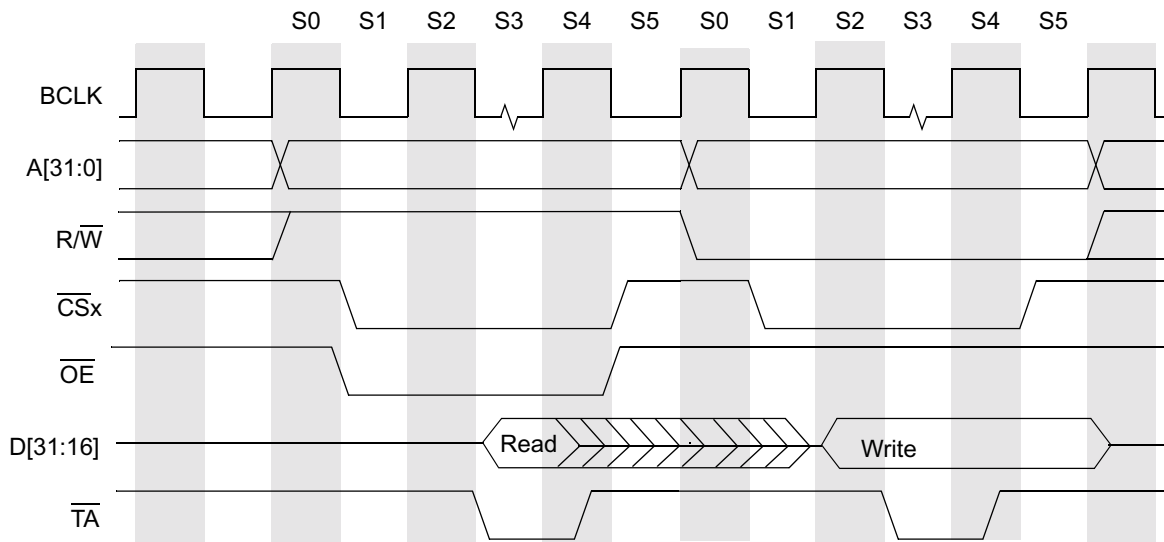

Figure 8-7 Back-to-Back Bus Cycles

8.5.5 BURST CYCLES

When burst read enable or burst write enable is asserted into the relevant chip select register, the MCF5249 will initiate burst cycles any time a transfer size is larger than the port size the MCF5249 is transferring to. A line transfer to a 16-bit port would constitute a burst cycle of eight words of data.

The MCF5249 bus can support 3-2-2-2 burst cycles to maximize cache performance and optimize DMA transfers. Users can add wait states if desired by delaying termination of the cycle.

Through the chip select control registers, users can enable bursting on reads or bursting on writes or bursting on both reads and writes if desired. In the MCF5249, any chip select can be declared “burst inhibited” by clearing the Chip-Select Burst Read-Enable and Burst Write-Enable bits for that region. If a line access is initiated to a region that is burst inhibited, back-to-back bus cycles will occur (See [Section 8.5.4 Back-to-Back Bus Cycles](#)).

8.5.5.1 Line Transfers

A line is defined as a 16-byte value, aligned in memory on 16-byte boundaries. Although the line itself is aligned on 16-byte boundaries, the line access does not necessarily begin on the aligned address. Therefore, the bus interface supports line transfers on multiple address boundaries. The allowable patterns during a line access are shown in [Table 8-7](#).

Table 8-7 Allowable Line Access Patterns

ADDR[3:2]	LONGWORD ACCESSES
00	0 - 4 - 8 - C
01	4 - 8 - C - 0
10	8 - C - 0 - 4
11	C - 0 - 4 - 8

8.5.5.2 Line Read Bus Cycles

[Figure 8-9](#) shows a line access read with zero wait states.

Note: The bus cycle begins similar to a basic read bus cycle with the first data transfer being sampled on the rising edge of S4. However, also notice that the next pipelined burst data is sampled one cycle later on the rising edge of S6. Each subsequent pipelined data burst will be single cycle until the last cycle which can be held for a maximum of 2 BCLK past the TA assertion. CS and OE remain asserted throughout the burst transfer.

[Figure 8-8](#) shows a line access read with one wait state. Wait states can be programmed in the chip select control register (CSCRs) to give the peripheral or memory more time to return read data. This figure follows the same execution as a zero-wait state read burst with the exception of an added wait state.

Freescale Semiconductor, Inc.

Data Transfer Operation

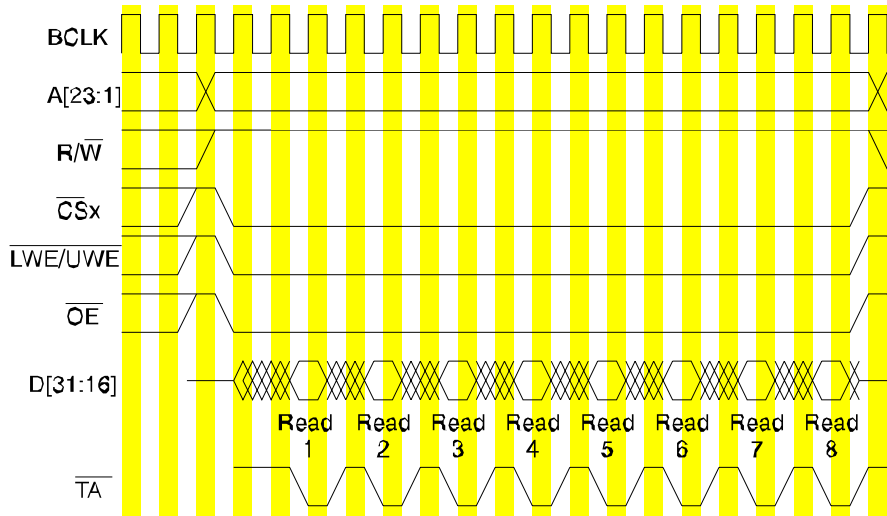

Figure 8-8 Line Read Burst (one wait cycle)

Figure 8-9 shows a line read burst with no wait cycles. In this example, the external device executes a basic read cycle while determining that a line is being transferred.

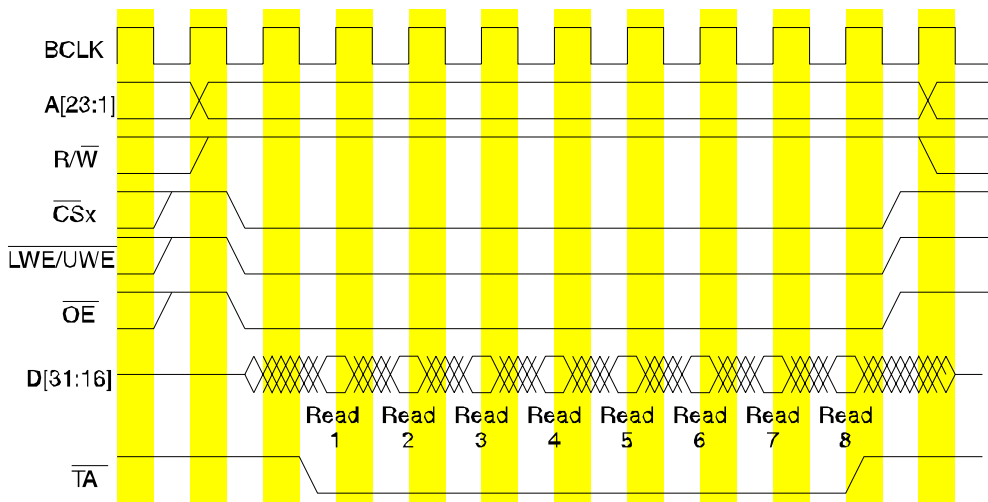

Figure 8-9 Line Read Burst (no wait cycles)

8.5.5.3 Line Write Bus Cycles

Figure 8-11 shows a line access write with zero wait states.

Note: The bus cycle begins similar to a basic write bus cycle with data being driven one clock after the address. Also notice that the next pipelined burst data is driven one cycle after the write data has been registered (on the rising edge of S6). Each subsequent pipelined write data burst will be a single cycle. CS remains asserted throughout the burst transfer.

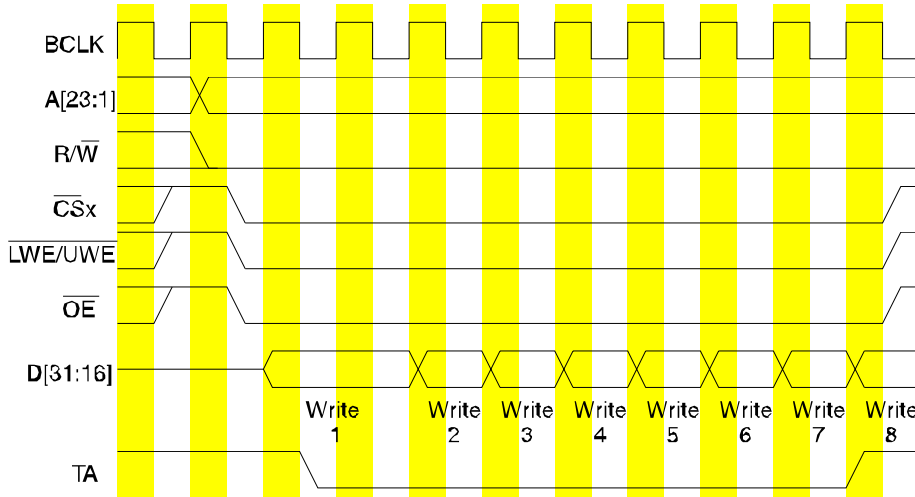

Figure 8-10 Line Write Burst (no wait cycles)

The following figure shows a burst inhibited line read.

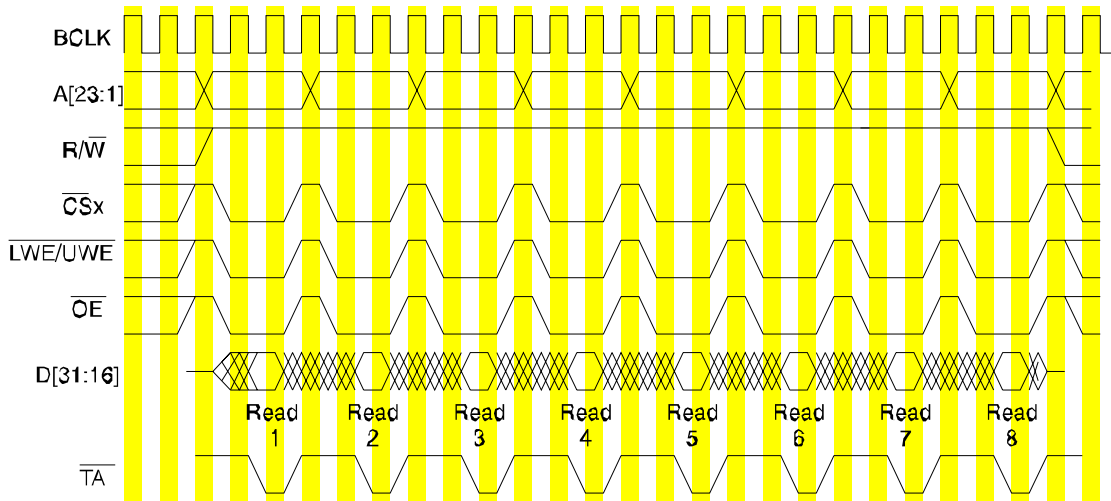

Figure 8-11 Line Read Burst-Inhibited

Figure 8-12 shows a line burst write with one state insertion.

Misaligned Operands

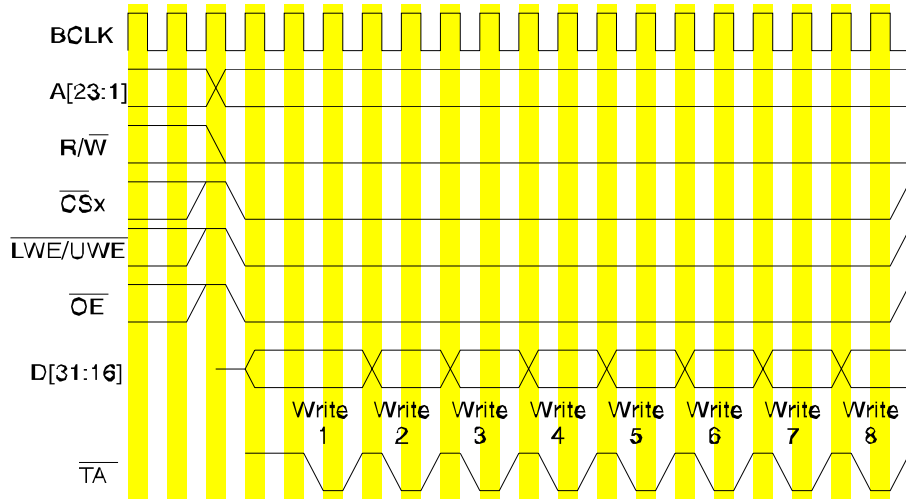

Figure 8-12 Line Write Burst with One Wait State

The following figure shows a burst-inhibited line write.

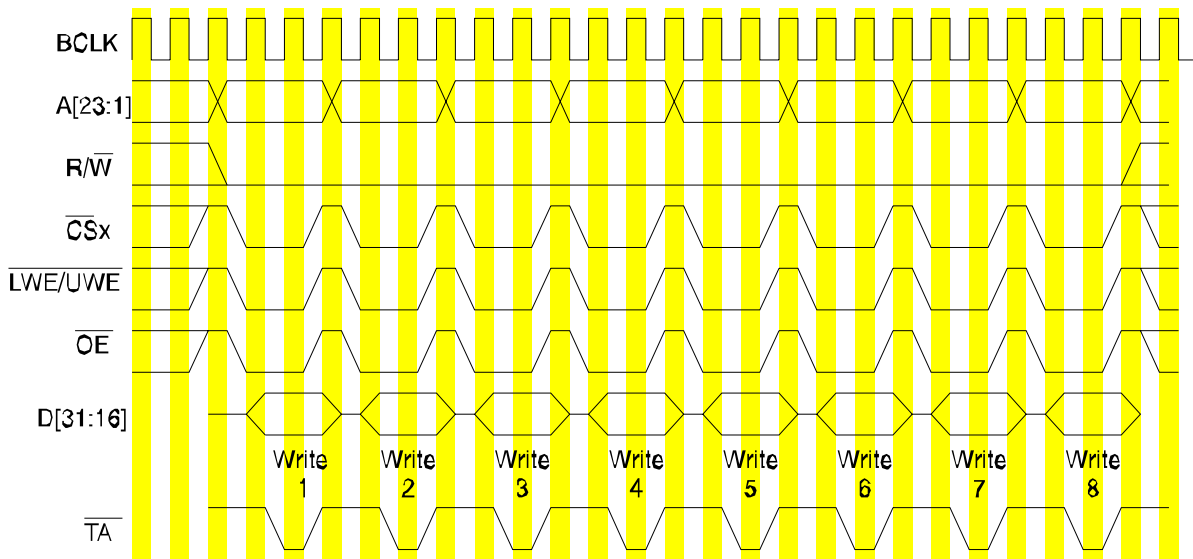

Figure 8-13 Line Write Burst-Inhibited

8.6 MISALIGNED OPERANDS

All MCF5249 data formats can be located in memory on any byte boundary. A byte operand is properly aligned at any address; a word operand is misaligned at an odd address; and a longword is misaligned at an address that is not evenly divisible by four. Unlike opcodes, because operands can reside at any byte boundary, they are allowed to be misaligned. Although the MCF5249 does not enforce any alignment restrictions for data operands (including program counter (PC) relative data addressing), some performance degradation occurs when additional bus cycles are required for longword or word operands that are misaligned. For maximum performance, data items should be aligned on their natural boundaries.

All instruction words and extension words (opcodes) must reside on word boundaries. An address error exception will occur with any attempt to prefetch an instruction word at an odd address.

The MCF5249 converts misaligned operand accesses that are noncacheable to a sequence of aligned accesses. Figure 8-14 illustrates the transfer of a longword operand from a byte address to a 32-bit port, requiring more than one bus cycle. The slave device supplies the byte and acknowledges the data transfer. The next two bytes are transferred during the second cycle. During the third cycle, the byte offset is now \$0; the port supplies the final byte and the operation is complete. Figure 8-15 is similar to the example illustrated in Figure 8-14 except that the operand is word-sized and the transfer requires only two bus cycles.

	31	24 23	16 15	8 7	0
TRANSFER 1	—	OP 3	—	—	
TRANSFER 2	—	—	OP 2	OP 1	
TRANSFER 3	OP 0	—	—	—	

Figure 8-14 Misaligned Longword Transfer

	31	24 23	16 15	8 7	0
TRANSFER 1	—	—	—	OP 1	
TRANSFER 2	OP 0	—	—	—	

Figure 8-15 Misaligned Word Transfer

8.7 RESET OPERATION

The MCF5249 processor supports one type of reset which resets the entire MCF5249: the external master reset input ($\overline{\text{RSTI}}$).

To perform a master reset, an external device asserts the reset input pin ($\overline{\text{RSTI}}$). When power is applied to the system, external circuitry should assert $\overline{\text{RSTI}}$ for a minimum of 16 CLKIN cycles after V_{CC} is within tolerance. Figure 8-16 is a functional timing diagram of the master reset operation, illustrating relationships among V_{CC} , $\overline{\text{RSTI}}$, mode selects, and bus signals. The crystal oscillation on CRIN, CROUT must be stable by the time V_{CC} reaches the minimum operating specification. The crystal should start oscillating as V_{CC} is ramped up to clear out contention internal to the MCF5249 processor caused by the random states of internal flip-flops on power up. $\overline{\text{RSTI}}$ is internally synchronized for two CLKIN cycles before being used and must meet the specified setup and hold times in relationship to CROUT to be recognized.

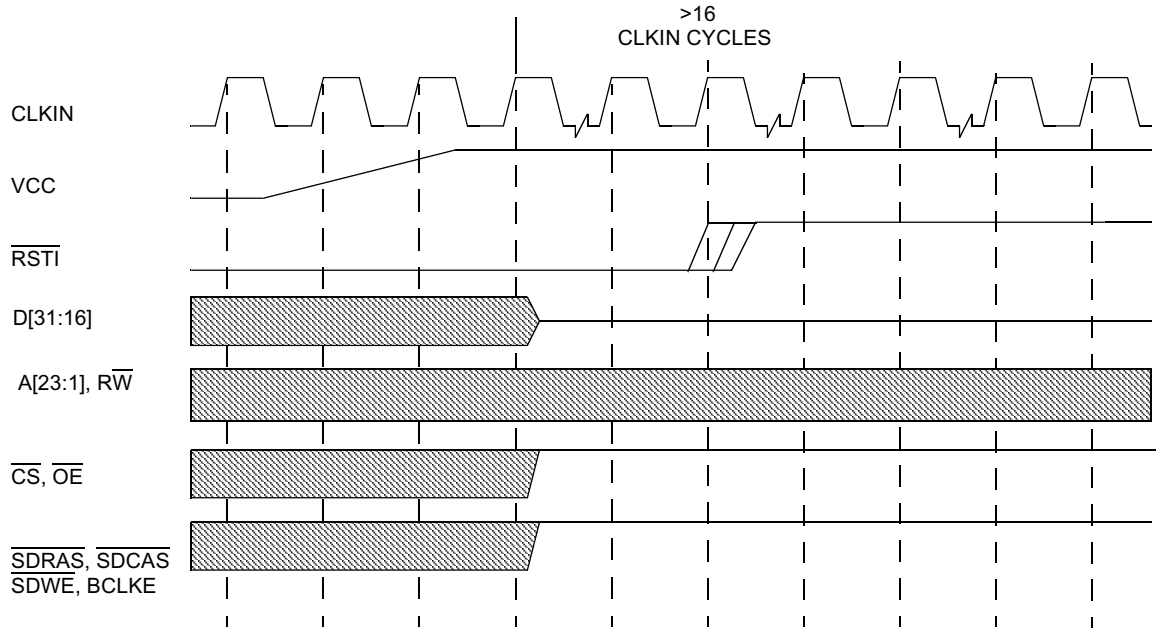

Figure 8-16 Master Reset Timing

During the master reset period, the data bus is being three-stated, the address bus is driven to any value, and all other bus signals are driven to their negated state. Once \overline{RSTI} negates, the bus stays in this state until the ColdFire core begins the first bus cycle for reset exception processing. A master reset causes any bus cycle (including DRAM refresh cycle) to terminate. In addition, master reset initializes registers appropriately for a reset exception.

At power-on reset, CS0 is configured to address the boot ROM. Boot ROM configuration is hard-wired inside the MCF5249 Configuration is summarized in table [Table 8-8](#).

Table 8-8 Power-on Reset Configuration for CS0

PORT SIZE	16 BITS
Cycle type	Internal termination, 15 wait cycles burst inhibit asserted for both read and write cycles

8.7.1 SOFTWARE WATCHDOG RESET

The software watchdog reset is performed anytime the executing software does not provide the correct write data sequence with the enable-control bit set. This reset helps prevent runaway software or nonterminated bus cycles. [Figure 8-17](#) is a functional timing diagram of the software watchdog reset operation, illustrating relationships among \overline{RSTO} and bus signals.

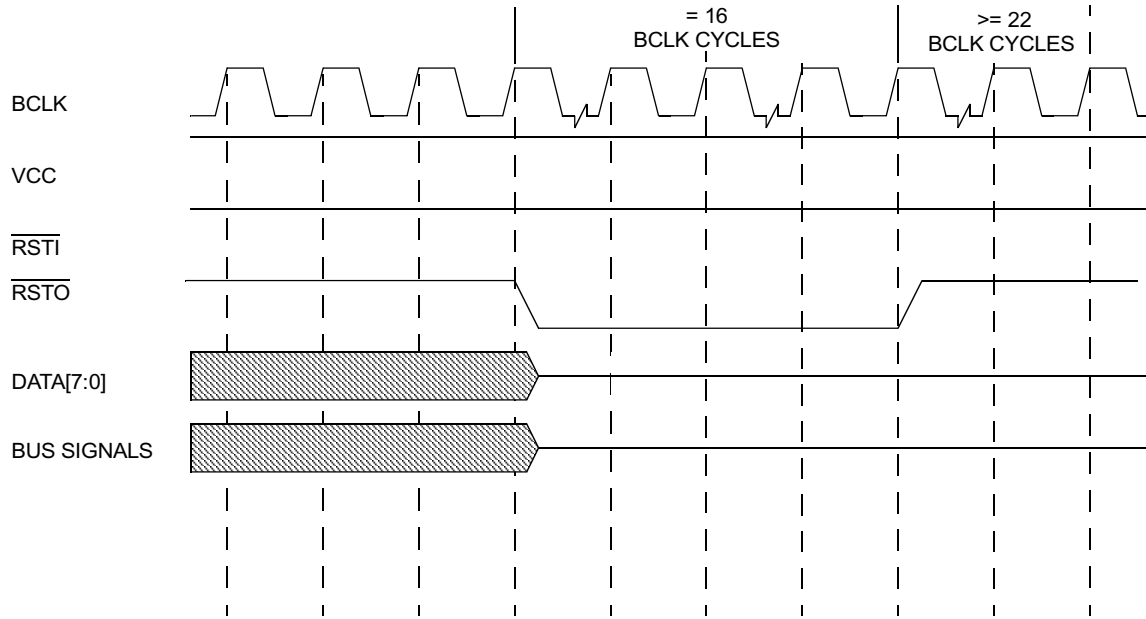

Figure 8-17 Software Watchdog Reset Timing

During the software watchdog reset period, all signals that can be driven to a high-impedance state and all those that cannot are driven to their negated states. Once \overline{RSTO} negates, all bus signals continue to remain in a high-impedance state until the ColdFire core begins the first bus cycle for reset exception processing.

NOTES

Section 9

System Integration Module

9.1 SIM INTRODUCTION

This section describes the operation and programming model of the System Integration Module (SIM) registers, including the interrupt controller and system-protection functions for the MCF5249. The SIM provides overall control of the internal and external buses and serves as the interface between the ColdFire core processor and the internal peripherals or external devices. The SIM also configures the general purpose input/output and enables the CPU STOP instruction.

9.1.1 SIM FEATURES

- Module Base Address Register (MBAR and MBAR2)
 - Base address location of all internal peripherals and SIM resources
 - Address space masking to internal peripherals and SIM resources
- Interrupt Controller
 - Two interrupt controllers
 - Programmable interrupt level (1-7) for internal peripheral interrupts
- System Protection and Reset Status
 - Reset status to indicate cause of last reset
 - Software watchdog timer with optional secondary bus monitor functionality
- Bus Arbitration Control Register (MPARK)
 - Enables display of internal accesses on the external bus for debug
- General purpose input/output registers
 - Defines general-purpose inputs and outputs
 - Edge interrupt triggers on general-purpose I/Os, 0 to 7
- Software interrupts
 - Allow programmer to make interrupt pending under software control

9.2 PROGRAMMING MODEL

9.2.1 SIM REGISTER MEMORY MAP

Table 9-1 shows the memory map of all the SIM registers. The internal registers in the SIM are memory-mapped registers offset from the MBAR or MBAR2 address pointers. The following list addresses some issues regarding the programming model table:

- The Module Base Address Registers are accessed in supervisor mode only using the MOVEC instruction.
- The MBAR and MBAR2 are accessible using the debug module as read/write registers.

Table 9-1 MBAR Register Addresses

ADDRESS	NAME	SIZE (BYTES)	DESCRIPTION
CPU + \$C0F	MBAR	4	Module base address register
CPU + \$C0E	MBAR2	4	Module base address register 2

Table 9-2 SIM Memory Map

ADDRESS	DESCRIPTION	0	1	2	3				
MBAR + \$000	SYSTEM CONTROL REG	RSR	SYPCR	SWIVR	SWSR				
MBAR + \$004		Reserved							
MBAR + \$008		Reserved							
MBAR + \$00C	BUS MASTER CONTROL REG	MPARK	Reserved						
MBAR + \$010	—	Reserved							
MBAR + \$014	—								
MBAR + \$018	—								
MBAR + \$01C	—								
MBAR + \$020	—								
MBAR + \$024	—								
MBAR + \$028	—								
MBAR + \$02C	—								
MBAR + \$030	—								
MBAR + \$034	—								
MBAR + \$038	—								
MBAR + \$03C	—								
MBAR + \$040	Primary interrupt Pending Reg					IPR			
MBAR + \$044	Primary Interrupt Mask Reg					IMR			
MBAR + \$04C	Primary Interrupt Control Reg	ICR0	ICR1	ICR2	ICR3				
MBAR + \$050	Primary Interrupt Control Reg	ICR4	ICR5	ICR6	ICR7				
MBAR + \$054	Primary Interrupt Control Reg	ICR8	ICR9	ICR10	ICR11				
MBAR2 + \$000	gpio 0-31 input reg	GPIO-READ (READ ONLY)							
MBAR2 + \$004	gpio 0-31 output reg	GPIO-OUT							
MBAR2 + \$008	gpio 0-31 output enable reg	GPIO-ENABLE							
MBAR2 + \$00C	gpio 0-31 function select	GPIO-FUNCTION							
MBAR + \$0AC	Device ID Reg								
MBAR2 + \$0B0	gpio 32-63 input reg	GPIO1-READ (READ ONLY)							
MBAR2 + \$0B4	gpio 32-63 output reg	GPIO1-OUT							

Table 9-2 SIM Memory Map (Continued)

ADDRESS	DESCRIPTION	0	1	2	3
MBAR2 + \$0B8	gpio 32-63 output enable reg	GPIO1-ENABLE			
MBAR2 + \$0BC	gpio 32-63 function select	GPIO1-FUNCTION			
MBAR2 + \$140	secondary interrupts 0-7 priority	INTPRI1			
MBAR2 + \$144	secondary interrupts 8-15 priority	INTPRI2			
MBAR2 + \$148	secondary interrupts 16-23 priority	INTPRI3			
MBAR2 + \$14C	secondary interrupts 24-31 priority	INTPRI4			
MBAR2 + \$150	secondary interrupts 32-39 priority	INTPRI5			
MBAR2 + \$154	secondary interrupts 40-47 priority	INTPRI6			
MBAR2 + \$158	secondary interrupts 48-55 priority	INTPRI7			
MBAR2 + \$15C	secondary interrupts 56-63 priority	INTPRI8			
MBAR2 + \$164	Spurious secondary interrupt vector	SPURVEC			
MBAR2 + \$168	secondary interrupt base vector register	INTBASE			
MBAR2 + \$198	software interrupts and interrupt monitor	EXTRAINT			

9.3 SIM PROGRAMMING AND CONFIGURATION

9.3.1 MODULE BASE ADDRESS REGISTERS

The base address of all internal peripherals is determined by the MBAR and MBAR2 registers.

The MBAR and MBAR2 are 32-bit write-only supervisor control register that physically reside in the SIM. They are accessed in the CPU address spaces \$C0F and \$C0E using the MOVEC instruction. Refer to the *ColdFire Family Programmer's Reference Manual* for use of MOVEC instruction. The MBAR and MBAR2 can be read when in debug mode using background debug commands.

At system reset, the MBAR valid bits (MBAR[0], MBAR2[0]) are cleared to prevent incorrect reference to resources before the MBAR or MBAR2 are written. The remainder of the MBAR or MBAR2 bits are uninitialized. To access the MBAR and MBAR2 peripherals, users should write MBAR and MBAR2 with the appropriate base address and set the valid bit after system reset.

The MBAR2 base address defines a single relocatable memory block along 1024-Mbyte boundaries. If the MBAR2 valid bit is set, the base address field is compared to the upper two bits of the full 32-bit internal address to determine if an MBAR2 peripheral is being accessed.

Any processor bus access is first compared for SRAM match (RAMBAR registers), then it is compared against MBAR and MBAR2. If no match is found in any of these registers, the cycle will be mapped to the Chip Select and SDRAM units.

Table 9-3 shows the bits in the module base address register (MBAR), and Table 9-5 shows the bits in the MBAR2.

Table 9-3 Module Base Address Register (MBAR)

BITS	31	30	29	28	27	26	25	24	23	22	21	20	19	18	17	16
FIELD	BA31	BA30	BA29	BA28	BA27	BA26	BA25	BA24	BA23	BA22	BA21	BA20	BA19	BA18	BA17	BA16
RESET	-	-	-	-	-	-	-	-	-	-	-	-	-	-	-	-
R/W	R/W	R/W	R/W	R/W	R/W	R/W	R/W	R/W	R/W	R/W	R/W	R/W	R/W	R/W	R/W	R/W
MBAR2BAS + 180																
BITS	15	14	13	12	11	10	9	8	7	6	5	4	3	2	1	0
FIELD	BA15	BA14	BA13	BA12				WP		AM	C/I	SC	SD	UC	UD	V
RESET	-	-	-	-	-	-	-	-	-	-	-	-	-	-	-	0
R/W	R/W	R/W	R/W	R/W				R/W		R/W	R/W	R/W	R/W	R/W	R/W	R/W
MBAR2BAS + 180																

Table 9-4 Module Base Address Bit Descriptions

BIT NAME	DESCRIPTION
BA[31:12]	The Base Address field defines the base address for a minimum 4-KByte address range.
WP	Attribute space mask. The Write Protect bit is the mask bit for write cycles in the MBAR-mapped register address range. 0 = module address range is read/write 1 = module address range is read only
AM	Attribute space mask. AM—Alternate Master Mask When AM = 0 and an alternate master actually accesses the MBAR-mapped registers; bits SC, SD, UC, and UD (MBAR[4:1]) are “don’t cares” in the address decoding. 0 = alternate master access allowed 1 = alternate master access masked
SC	Attribute space mask. Mask Supervisor Code space in MBAR address range 0 = supervisor code access allowed 1 = supervisor code access masked
SD	Attribute space mask. Mask Supervisor Data space in MBAR address range 0 = supervisor data access allowed 1 = supervisor data access masked
C/I	Attribute space mask. Mask CPU Space and Interrupt Acknowledge Cycle 0 = IACK cycle mapped to MBAR space 1 = IACK cycle not responded to by MBAR peripherals
UC	Attribute space mask. Mask User Code space in MBAR address range 0 = user code access allowed 1 = user code access masked
UD	Attribute space mask. Mask User Data space in MBAR address range 0 = user data space access allowed 1 = user data space access masked

Table 9-4 Module Base Address Bit Descriptions (Continued)

BIT NAME	DESCRIPTION
V	This bit defines when the base address is valid: 0 = MBAR address space not visible by CPU 1 = MBAR address space visible by CPU

The following example shows how to set the MBAR to location \$10000000 using the D0 register. A “1” in the least significant bit validates the MBAR location. This example assumes that all accesses are valid:

```
move.1 #10000001,D0
movec DO,MBAR
```

Table 9-5 Second Module Base Address Register (MBAR2)

BITS	31	30	29	28	27	26	25	24	23	22	21	20	19	18	17	16
FIELD	BA31	BA30	-	-	-	-	-	-	-	-	-	-	-	-	-	-
RESET	0	0	-	-	-	-	-	-	-	-	-	-	-	-	-	-
R/W	R/W	R/W														
BITS	15	14	13	12	11	10	9	8	7	6	5	4	3	2	1	0
FIELD									LS7	LS6	LS5	LS4	LS3	LS2	LS1	V
RESET	-	-	-	-	-	-	-	-	0	0	0	0	0	0	0	0
R/W									R/W	R/W	R/W	R/W	R/W	R/W	R/W	R/W

Table 9-6 Second Module Base Address Bit Descriptions

BIT NAME	DESCRIPTION
BA[31:30]	The Base Address field defines the base address for a 1024-MByte address range. If V-bit in MBAR2 is set, address range Base Address to BaseAddress + \$3FFF FFFF are mapped to MBAR2 space, and cannot be used for MBAR, SDRAM or Chip Select.
LS[7:1]	If interrupts both “primary” and the “secondary” interrupt controller have interrupt level 7 pending, bit LS7 determines which interrupt controller gets priority. If this bit is cleared, the primary interrupt controller gets priority. If this bit is set, the secondary interrupt controller gets priority. There are 7 LSn bits, one for each interrupt level.
V	The Valid bit defines if the CPU can access the MBAR2 mapped peripherals 0 = MBAR2 address space not visible by CPU. 1 = MBAR2 address space visible by CPU

9.3.2 DEVICE ID

The DeviceID register is a read only register that allows the software to determine which hardware it is running on. The register contains the part number in the upper 24 bits, the mask revision number in the lower 8 bits, and is read as 0x005448rr, where rr is the revision number.

This register allows developers the flexibility to write code to run on more than one device. The revision number allows developers to distinguish between different mask versions that may have minor changes or

Interrupt Interface

bug fixes. For example, developers may want to distribute a single code image or library for use on different revisions of the silicon.

Table 9-7 DeviceID Register (DeviceID)

BITS	31	30	29	28	27	26	25	24	23	22	21	20	19	18	17	16
FIELD	PART NUMBER															
RESET	-	-	-	-	-	-	-	-	-	-	-	-	-	-	-	-
R/W	READ ONLY															
BITS	15	14	13	12	11	10	9	8	7	6	5	4	3	2	1	0
FIELD	PART NUMBER								MASK REVISION							
RESET	-	-	-	-	-	-	-	-	-	-	-	-	-	-	-	0
R/W	READ ONLY															
ADDR	MBAR+2 0xAC															

9.3.3 INTERRUPT CONTROLLER

For legacy reasons, there are two interrupt controllers on the MCF5249.

1. The *primary* interrupt controller offers the same functionality as the MCF5307 interrupt controller.
2. The *secondary* interrupt controller offers additional interrupts for on-chip peripheral devices that are not present in the MCF5307.

The primary interrupt controller is centralized, and services the following:

- Software watchdog timer
- Timer modules
- I²C 1 module
- UART modules
- DMA module
- QSPI module

The secondary interrupt controller is decentralized, and services the following:

- gpio interrupts
- Audio interface module
- MemoryStick/SD module
- AD convertor module
- I²C 2 module

9.4 INTERRUPT INTERFACE

9.4.1 PRIMARY CONTROLLER INTERRUPT REGISTERS

Primary internal interrupt sources have their own interrupt control registers ICR[11:0], IPR, and IMR. [Table 9-7](#) gives the location and description of each ICR.

Table 9-8 Primary Interrupt Control Register Memory Map

ADDRESS	NAME	WIDTH	DESCRIPTION	RESET VALUE	ACCESS
MBAR + \$04C	ICR0	8	SWT	\$00	R/W
MBAR + \$04D	ICR1	8	TIMER 0	\$00	R/W
MBAR + \$04E	ICR2	8	TIMER 1	\$00	R/W
MBAR + \$04F	ICR3	8	I ² C	\$00	R/W
MBAR + \$050	ICR4	8	UART 1	\$00	R/W
MBAR + \$051	ICR5	8	UART 2	\$00	R/W
MBAR + \$052	ICR6	8	DMA 0	\$00	R/W
MBAR + \$053	ICR7	8	DMA 1	\$00	R/W
MBAR + \$054	ICR8	8	DMA 2	\$00	R/W
MBAR + \$055	ICR9	8	DMA 3	\$00	R/W
MBAR + \$056	ICR10	8	QSPI	\$00	R/W
MBAR + \$057	ICR11	8	Reserved	—	—

Primary interrupts are programmed to a level and priority. All primary interrupts have a unique Interrupt Control Register (ICR). There are 28 possible priority levels, encompassing primary interrupts.

The bits of the ICR are shown in [Table 9-9](#).

Table 9-9 Interrupt Control Register (ICR)

BITS	7	6	5	4	3	2	1	0
FIELD	AVEC	-	-	IL[2]	IL[1]	IL[0]	IP[1]	IP[0]
RESET	0	-	-	0	0	0	0	0
R/W	R/W			R/W	R/W	R/W	R/W	R/W

Table 9-10 Interrupt Control Bit Descriptions

BIT NAME	DESCRIPTION
AVEC	The Autovector Enable bit determines whether the interrupt-acknowledge cycle input (for the internal interrupt level indicated in IL[2:0] for each interrupt) requires an autovector response. 0 = Interrupting source returns vector during interrupt-acknowledge cycle 1 = SIM generates auto vector during interrupt acknowledge cycle
IL[2:0]	The Interrupt Level bits indicate the interrupt level assigned to each interrupt input.
IP[1:0]	The Interrupt Priority bits indicate the interrupt priority within the interrupt level assignment. Table 9-11 shows the priority levels associated with the IP contents.

Table 9-11 Interrupt Priority Assignment

IP[1:0]	PRIORITY
00	Lower
01	Low
10	High
11	Higher

Table 9-12 shows all possible primary source priority schemes for the MCF5249. The interrupt source in this table can be any internal interrupt source programmed to the given level and priority. For example, assume that two internal interrupt sources were programmed to IL[2:0] = 110, one having a priority of IP[1:0] = 01 and one having a priority of IP[1:0] = 10. If both assert an interrupt request at the same time, the order of servicing would occur as follows:

1. Internal module with IL[2:0] = 110 and IP[1:0] = 10 would be serviced first
2. Internal module with IL[2:0] = 110 and IP[1:0] = 01 would be serviced last

Table 9-12 Interrupt Priority Scheme

INTERRUPT LEVEL	INTERNAL MODULE ICR REG			INTERRUPT SOURCE
	IL[2:0]	IP[1]	IP[0]	
7	111	1	1	Internal Module
7	111	1	0	Internal Module
7	111	0	1	Internal Module
7	111	0	0	Internal Module
6	110	1	1	Internal Module
6	110	1	0	Internal Module
6	110	0	1	Internal Module
6	110	0	0	Internal Module
5	101	1	1	Internal Module
5	101	1	0	Internal Module
5	101	0	1	Internal Module
5	101	0	0	Internal Module
4	100	1	1	Internal Module
4	100	1	0	Internal Module
4	100	0	1	Internal Module
4	100	0	0	Internal Module

Table 9-12 Interrupt Priority Scheme (Continued)

INTERRUPT LEVEL	INTERNAL MODULE ICR REG			INTERRUPT SOURCE
	IL[2:0]	IP[1]	IP[0]	
3	011	1	1	Internal Module
3	011	1	0	Internal Module
3	011	0	1	Internal Module
3	011	0	0	Internal Module
2	010	1	1	Internal Module
2	010	1	0	Internal Module
2	010	0	1	Internal Module
2	010	0	0	Internal Module
1	001	1	1	Internal Module
1	001	1	0	Internal Module
1	001	0	1	Internal Module
1	001	0	0	Internal Module

Note: Multiple internal modules shall not be assigned to the same interrupt level and same interrupt priority when configuring the ICR registers. This can cause erratic chip behavior.

9.4.1.1 Interrupt Mask Register

The IMR register is used to mask both internal and external interrupt sources from occurring.

Table 9-13 Interrupt Mask Register (IMR)

BITS	31	30	29	28	27	26	25	24	23	22	21	20	19	18	17	16
FIELD														QSPI	DMA 3	DMA 2
RESET	—	—	—	—	—	—	—	—	—	—	—	—	—	1	1	1
R/W														R/W	R/W	R/W
BITS	15	14	13	12	11	10	9	8	7	6	5	4	3	2	1	0
FIELD	DMA 1	DMA 0	UART 1	UART 0	I ² C	TIMER1	TIMER0	SWT	—	—	—	—	—	—	—	—
RESET	1	1	1	1	1	1	1	1	1	1	1	1	1	1	1	—
R/W	R/W															
ADDRESS MBAR (0 X 44)																

Table 9-14 Interrupt Mask Bit Descriptions

BIT NAME	DESCRIPTION
IMR[17:8]	<p>Each Interrupt Mask bit corresponds to an interrupt source defined in the Interrupt Control Register (ICR). An interrupt is masked by setting the corresponding bit in the IMR. When a masked interrupt occurs, the corresponding bit in the IPR is still set, regardless of the setting of the IMR bit, but no interrupt request is passed to the core processor. At system reset, all defined bits are initialized high, thereby masking all interrupts.</p> <p>The proper procedure for masking interrupt sources is to first set the core's status register interrupt mask level to the level of the source being masked in the IMR. Then, the IMR bit can be masked.</p> <p>An interrupt can be masked by setting the corresponding bit in the IMR and enable an interrupt by clearing the corresponding bit in the IMR. When a masked interrupt occurs, the corresponding bit in the IPR is still set, regardless of the setting of the IMR bit, but no interrupt request is passed to the core processor.</p>
RES[7:1]	Reserved.

9.4.1.2 Interrupt Pending Register

The IPR makes visible the interrupt sources that have an interrupt pending.

Table 9-15 Interrupt Pending Register (IPR)

BITS	31	30	29	28	27	26	25	24	23	22	21	20	19	18	17	16
FIELD														QSPI	DMA 3	DMA 2
RESET	—	—	—	—	—	—	—	—	—	—	—	—	—	—	—	—
BITS	15	14	13	12	11	10	9	8	7	6	5	4	3	2	1	0
FIELD	DMA 1	DMA 0	UART 1	UART 0	I ² C	TIMER1	TIMER0	SWT	—	—	—	—	—	—	—	—
RESET	—	—	—	—	—	—	—	—	—	—	—	—	—	—	—	—
MBAR (0X40)																

Table 9-16 Interrupt Pending Bit Descriptions

BIT NAME	DESCRIPTION
IPR[18:8]	<p>Each Interrupt Pending bit corresponds to an interrupt source defined by the Interrupt Control Register. At every clock this register samples the signal generated by the interrupting source. The corresponding bit in this register reflects the state of the interrupt signal even if the corresponding mask bit were set. The IPR is a read-only longword register.</p> <p>0 = The corresponding interrupt source does not have an interrupt pending 1 = The corresponding interrupt source has an interrupt pending</p>
RES[7:1]	Reserved.

9.4.2 SECONDARY INTERRUPT CONTROLLER REGISTERS

A second interrupt controller was added to the MCF5249. The secondary controller serves 64 interrupt sources with programmable interrupt levels. All 64 interrupts are auto-vectored. Interrupt pending registers and interrupt mask registers are decentralized, and available in the modules that own the interrupts.

Table 9-17 Secondary Interrupt Controller Registers Memory Map

ADDRESS	NAME	WIDTH	DESCRIPTION	RESET VALUE	ACCESS
MBAR2 + \$140	INTPRI1	32	Interrupts 0-7 priority	\$00	R/W
MBAR2 + \$144	INTPRI2	32	Interrupts 8-15 priority	\$00	R/W
MBAR2 + \$148	INTPRI3	32	Interrupts 16-23 priority	\$00	R/W
MBAR2 + \$14C	INTPRI4	32	Interrupts 24-31 priority	\$00	R/W
MBAR2 + \$150	INTPRI5	32	Interrupts 32-39 priority	\$00	R/W
MBAR2 + \$154	INTPRI6	32	Interrupts 40-47 priority	\$00	R/W
MBAR2 + \$158	INTPRI7	32	Interrupts 48-55 priority	\$00	R/W
MBAR2 + \$15C	INTPRI8	32	Interrupts 56-63 priority	\$00	R/W
MBAR2 + \$16B	INTBASE	8	Interrupt base vector	\$00	R/W
MBAR2 + \$167	SPURVEC	8	spurious vector	\$00	R/W

9.4.2.1 Interrupt Level Selection

The interrupt level, `intpri[1:8]`, of the 64 interrupts serviced by the secondary interrupt controller can be programmed for every interrupt separately. Every interrupt is given a 4-bit field in one of the interrupt priority register. This 4-bit field controls level setting for the interrupt. Values 1-7 correspond with ColdFire interrupt priorities. Value 0 is off.

Table 9-18 Secondary Interrupt Level Programming Bit Assignment

ADDRESS	NAME	BIT 31-28	BIT 27-24	BIT 23-20	BIT 19-16	BIT 15-12	BIT 11-8	BIT 7-4	BIT 3-0
MBAR2 + \$140	INTPRI1	INT7	INT6	INT5	INT4	INT3	INT2	INT1	INT0
MBAR2 + \$144	INTPRI2	INT15	INT14	INT13	INT12	INT11	INT10	INT9	INT8
MBAR2 + \$148	INTPRI3	INT23	INT22	INT21	INT20	INT19	INT18	INT17	INT16
MBAR2 + \$14C	INTPRI4	INT31	INT30	INT29	INT28	INT27	INT26	INT25	INT24
MBAR2 + \$150	INTPRI5	INT39	INT38	INT37	INT36	INT35	INT34	INT33	INT32
MBAR2 + \$154	INTPRI6	INT47	INT46	INT45	INT44	INT43	INT42	INT41	INT40
MBAR2 + \$158	INTPRI7	INT55	INT54	INT53	INT52	INT51	INT50	INT49	INT48
MBAR2 + \$15C	INTPRI8	INT63	INT62	INT61	INT60	INT59	INT58	INT57	INT56

Interrupt Interface

9.4.2.2 Interrupt Vector Generation

All secondary interrupts are autovectored. The vector number for interrupt 0 is given by register INTBASE. The vector numbers for the other interrupts are offset from this number. Vector number for interrupt 23 is e.g. INTBASE + 23. The secondary interrupt controller will generate vector numbers INTBASE to INTBASE + 63 for its 64 interrupts.

Table 9-19 intBase Register Description

BITS	7	6	5	4	3	2	1	0
FIELD	BASE[7]	BASE[6]	BASE[5]	BASE[4]	BASE[3]	BASE[2]	BASE[1]	BASE[0]
RESET	0	0	0	0	0	0	0	0
R/W	R/W	R/W	R/W	R/W	R/W	R/W	R/W	R/W
ADDR	MBAR2 + \$16B							

Table 9-20 intBase Bit Descriptions

BIT NAME	DESCRIPTION
BASE[7:0]	This is the 8-bit interrupt vector for interrupt 0. Vector numbers for other interrupts are obtained by adding the interrupt number to BASE. E.g. INTERRUPT 23 VECTOR IS BASE + 23.

9.4.2.3 Spurious Vector Register

Table 9-21 spurvec Register Description

BITS	7	6	5	4	3	2	1	0
FIELD	SPURVEC[7]	SPURVEC[6]	SPURVEC[5]	SPURVEC[4]	SPURVEC[3]	SPURVEC[2]	SPURVEC[1]	SPURVEC[0]
RESET	—	—	—	—	—	—	—	—
R/W	R/W	R/W	R/W	R/W	R/W	R/W	R/W	R/W
ADDR	MBAR2 + \$167							

The SPURVEC register contains the interrupt vector number that is fed when a spurious interrupt event occurs on the secondary interrupt controller. A spurious interrupt occurs when a pending interrupt causes the ColdFire processor to feed an interrupt vector, but before the interrupt vector can be fed, the pending interrupt disappeared.

9.4.2.4 Secondary Interrupt Sources

The 64 secondary interrupts are used by modules as detailed in [Table 9-22](#).

Table 9-22 Secondary Interrupt Sources

INTERRUPT	INTERRUPT NAME	MODULE	DESCRIPTION
63	A/D	A/D	A to D convertor
62	IIC2	IIC2	iic2 interrupt
61	IPADDRESSERROR	SIM	IP address error cycle interrupt ^b

Table 9-22 Secondary Interrupt Sources (Continued)

INTERRUPT	INTERRUPT NAME	MODULE	DESCRIPTION
60		FLASHINTER	SD/MemoryStick interrupt
59		FLASHINTER	SD/MemoryStick interrupt
58		FLASHINTER	SD/MemoryStick interrupt
57		FLASHINTER	SD/MemoryStick interrupt
56	CDROMNEWBLOCK	AUDIO	CD-ROM new block interrupt
55	CDROMILSYNC	AUDIO	CD-ROM ilsync interrupt
54	CDROMNOSYNC	AUDIO	CD-ROM nosync interrupt
53	CDROMCRCERR	AUDIO	CD-ROM crc error interrupt
52			
51			
50	SOFTINT3	AUXINT	Software interrupt 3
49	SOFTINT2	AUXINT	Software interrupt 2
48	SOFTINT1	AUXINT	Software interrupt 1
47	SOFTINT0	AUXINT	Software interrupt 0
46			
45			
44			
43			
42			
41			
40			
39	GPI7	SIM	gpio interrupt ^a
38	GPI6	SIM	gpio interrupt
37	GPI5	SIM	gpio interrupt
36	GPI4	SIM	gpio interrupt
35	GPI3	SIM	gpio interrupt
34	GPI2	SIM	gpio interrupt
33	GPI1	SIM	gpio interrupt
32	GPI0	SIM	gpio interrupt
31	IIS1TXUNOV	AUDIO	iis1 transmit fifo under / over
30	IIS1TXRESYN	AUDIO	iis1 transmit fifo resync
29	IIS2TXUNOV	AUDIO	iis2 transmit fifo under / over
28	IIS2TXRESYN	AUDIO	iis2 transmit fifo resync
27	EBUTXUNOV	AUDIO	IEC958 transmit fifo under / over
26	EBUTXRESYN	AUDIO	IEC958 transmit fifo resync
25	IEC958-1 CNEW	AUDIO	IEC958-1 receives new C control channel frame
24	IEC958-1 VAL NOGOOD	AUDIO	IEC958 validity flag no good
23	IEC958-1 PARITY OR SYMBOL ERROR	AUDIO	IEC958 receiver 1 bit or symbol error
22	PDIR3UNOV	AUDIO	Processor data in 3 under/over
21	UCHANTXEMPTY	AUDIO	U channel transmit register is empty
20	UCHANTXUNDER	AUDIO	U channel transmit register underrun
19	UCHANTX NEXTFIRST	AUDIO	U channel transmit register next byte will be first
18	IEC958-1 U/Q BUFFER ATTENTION	AUDIO	IEC 958 -1 U/Q channel buffer full interrupt
17	IEC958-2 CNEW	AUDIO	New C-channel received on IEC958-2

Table 9-22 Secondary Interrupt Sources (Continued)

INTERRUPT	INTERRUPT NAME	MODULE	DESCRIPTION
16	IEC958-2 VALNOGOOD	AUDIO	Validity flag not good on IEC958-2
15	IEC958-2 PARITY ERROR OR SYMBOL ERROR	AUDIO	IEC958-2 receiver parity error or symbol error
14	IEC958-2 U/Q BUFFER ATTENTION	AUDIO	IEC958-2 U/Q channel buffer full interrupt
13	U1CHANRCVOVER Q1CHANOVERRUN UQ1CHANERR	AUDIO	IEC958 receiver 1U/Q channel error
12	PDIR1UNOV	AUDIO	processor data in 1 under / over
11	PDIR1RESYN	AUDIO	processor data in 1 resync
10	PDIR2UNOV	AUDIO	Processor data in 2 under / over
9	PDIR2RESYN	AUDIO	Processor data in 2 resync
8	AUDIOTICK	AUDIO	"tick" interrupt
7	U2CHANRCVOVER Q2CHANOVERRUN UQ2CHANERR	AUDIO	IEC 958 receiver 2 U/Q channel error
6	PDIR3 RESYNC	AUDIO	Processor data in 3 resync
5	PDIR3 FULL	AUDIO	Processor data in 3 full
4	IIS1TXEMPTY	AUDIO	IIS1 transmit fifo empty
3	IIS2TXEMPTY	AUDIO	IIS2 transmit fifo empty
2	EBUTXEMPTY	AUDIO	ebu transmit fifo empty
1	PDIR2 FULL	AUDIO	Processor data in 2 full
0	PDIR1 FULL	AUDIO	Processor data in 1 full

- Set the GPIO_FUNCTION register bit to 1 or 0 for interrupts, as applicable.
- This interrupt triggers if an IP bus peripheral generates a Transfer Error Acknowledge interrupt on the IP bus. This interrupt is used for s/w debug and should not normally be generated. This interrupt maybe generated if for example one of the Audio FIFO 's is accessed in byte or word mode.

For Interrupt 57-60, see [Table 9-23](#).

Table 9-23 FlashMedia Interrupt Interface

FLASHMEDIAINTSTAT FLASHMEDIAINTEN FLASHMEDIAINTCLEAR BITS	INT NAME	MEANING	RESET INTERRUPT	ASSOCIATED INTERRUPT
0	SHIFTBUSY1FALL	interrupt set on falling edge of shift_busy_1	intClear	60
1	SHIFTBUSY1RISE	interrupt set on rising edge of shift_busy_1	intClear	60
2	INTLEVEL1FALL	interrupt set on falling edge of int_level_1	intClear	60
3	INTLEVEL1RISE	interrupt set on rising edge of int_level_1	intClear	60
4	SHIFTBUSY2FALL	interrupt set on falling edge of shift_busy_2	intClear	59
5	SHIFTBUSY2RISE	interrupt set on rising edge of shift_busy_2	intClear	59
6	INTLEVEL2FALL	interrupt set on falling edge of int_level_2	intClear	59
7	INTLEVEL2RISE	interrupt set on rising edge of int_level_2	intClear	59
8	RCV1FULL	interrupt set if receive buffer reg 1 full	read data	58
9	TX1EMPTY	interrupt set if transmit buffer reg 1 empty	write data	58

Table 9-23 FlashMedia Interrupt Interface (Continued)

FLASHMEDIAINTSTAT FLASHMEDIAINTEN FLASHMEDIAINTCLEAR BITS	INT NAME	MEANING	RESET INTERRUPT	ASSOCIATED INTERRUPT
10	RCV2FULL	interrupt set if receive buffer reg 2 full	read data	57
11	TX2EMPTY	interrupt set if transmit buffer reg 2 empty	write data	57

9.4.3 SOFTWARE INTERRUPTS

The MCF5249 supports four software interrupts. These interrupts are activated by writing a “1” to an extraint register bit. When active, the interrupts can generate a normal interrupt exception to the ColdFire processor. The interrupt exception is only generated if the corresponding level register interrupt mask is higher than the current processor interrupt mask.

Table 9-24 Extraint Register Descriptions

EXTRAIINT MBAR2 + 198 BIT FIELD	NAME	ACCESS	DESCRIPTION	INT NO	NOTE
3,7	SOFTINT3	R	read softint3 value	50	1,2
2,6	SOFTINT2	R	read softint2 value	49	1,2
1,5	SOFTINT1	R	read softint1 value	48	1,2
0,4	SOFTINT0	R	read softint0 value	47	1,2
7	SOFTINT3_SET	W	write one to this bit to set softint3	50	1
6	SOFTINT2_SET	W	write one to this bit to set softint2	49	1
5	SOFTINT1_SET	W	write one to this bit to set softint1	48	1
4	SOFTINT0_SET	W	write one to this bit to set softint0	47	1
3	SOFTINT3_CLR	W	write one to this bit to clear softint3	50	2
2	SOFTINT2_CLR	W	write one to this bit to clear softint2	49	2
1	SOFTINT1_CLR	W	write one to this bit to clear softint1	48	2
0	SOFTINT0_CLR	W	write one to this bit to clear softint0	47	2

Note: Bits 7-4 of the register return on read the value of the software interrupts 0-3. When written zero, the value of the corresponding software interrupt will not change. When written one, the corresponding software interrupt is set to 1.

Note: Bits 3-0 of the register return on read the value of software interrupts 0-3. When written zero, the value of the corresponding software interrupt will not change. When written one, the corresponding software interrupt is set to 0.

9.5 SYSTEM PROTECTION AND RESET STATUS

9.5.1 RESET STATUS REGISTER

The RSR contains a bit for each reset source to the SIM. A bit set to 1 indicates the last type of reset that occurred. The RSR is updated by the reset control logic on completion of the reset operation. Only one bit will be set at any given time in the RSR. The register reflects the cause of the most recent reset. If a reset occurs and the user failed to clear this register, reset control logic will clear all bits and set the appropriate bit to indicate the current cause of reset. The RSR programming model is illustrated as follows.

The Reset Status Register (RSR) is an 8-bit supervisor read-write register.

Table 9-25 Reset Status Register (RSR)

BITS	7	6	5	4	3	2	1	0
FIELD	HRST	—	SWTR	—	—	—	—	—
RESET	1	0	0	0	0	0	0	0
R/W	R/W	R/W	R/W					
ADDR	MBAR + \$(0X00)							

Table 9-26 Reset Status Bit Descriptions

BIT NAME	DESCRIPTION
HRST	For the Hardware or System Reset, a 1 = An external device driving \overline{RSTI} caused the last reset. Assertion of reset by an external device causes the core processor to take a reset exception. All registers in internal peripherals and the SIM are reset.
SWTR	For the Software Watchdog Timer Reset, a 1 = The last reset was caused by the software watchdog timer. If SWRI in the SYPCR is set and the software watchdog timer times out, a hardware reset occurs.

9.5.2 SOFTWARE WATCHDOG TIMER

The SWT prevents system lockup should the software become trapped in loops with no controlled exit. The SWT can be enabled or disabled using the SWE bit in the SYPCR. If enabled, the SWT requires the execution of a software watchdog servicing sequence periodically. If this periodic servicing action does not occur, the SWT times out resulting in a $\overline{SWT\ IRQ}$ or hardware reset, as programmed by the SWRI bit in the SYPCR. If the SWT times out and software watchdog transfer acknowledge enable (SWTA = SYPCR[2]) bit is set in the system protection control register, the $\overline{SWT\ IRQ}$ will assert. If after another timeout and the SWT IACK cycle has not occurred, the $\overline{SWT\ TA}$ signal will assert in an attempt to terminate the bus cycle and allow IACK cycle to proceed. The setting of the SWTAVAL flag bit (SYPCR[1]) in the system protection control register indicates that the $\overline{SWT\ TA}$ signal was asserted. The SWTA function when terminating a locked bus is shown in [Figure 9-1](#).

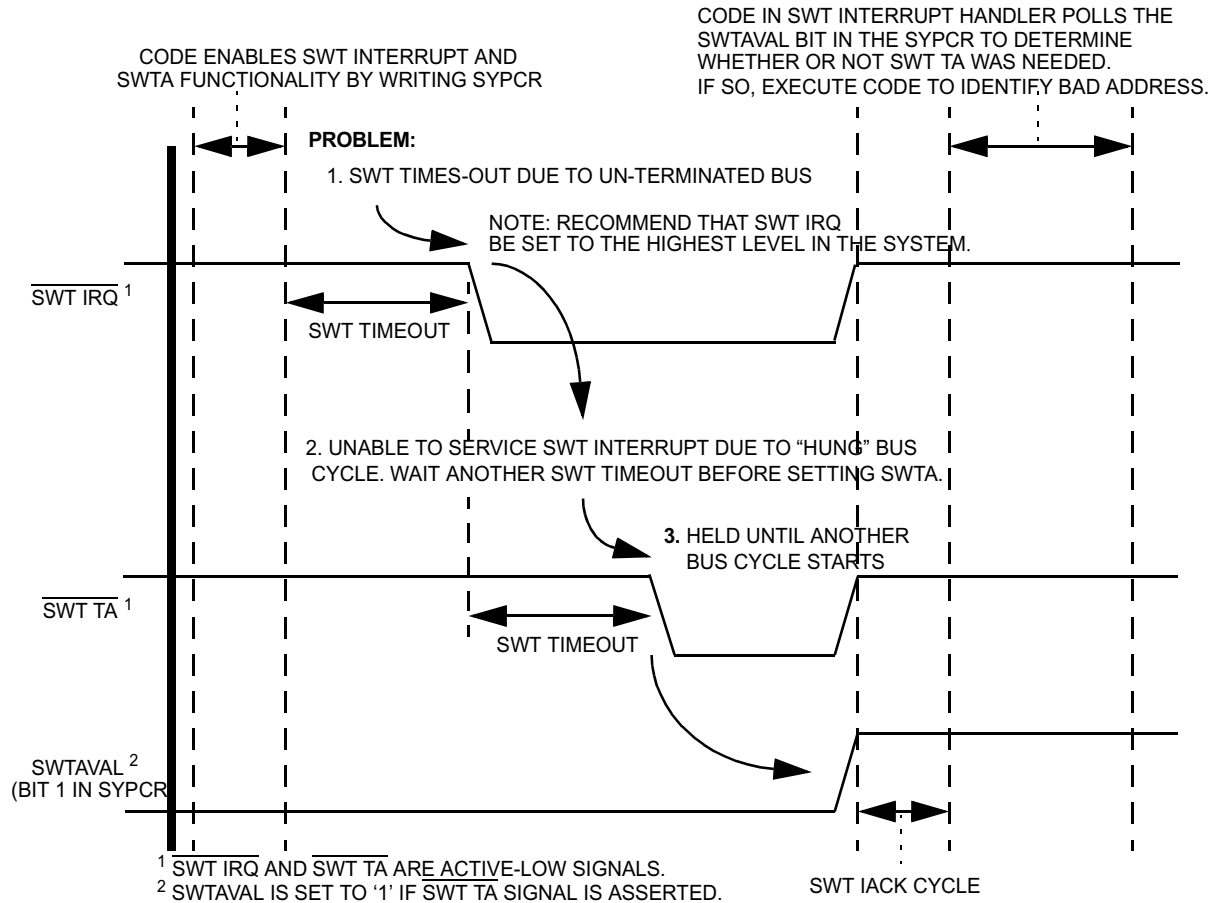

Figure 9-1 MCF5249 Underminated Access Recovery

When the SWT times out and SWRI register bit is programmed for a software reset, an internal reset will be asserted, and the SWTR register bit will be set in the RSR.

To prevent SWT from interrupting or resetting, users must service the SWSR register. The SWT service sequence consists of the following steps:

1. Write \$55 to SWSR
2. Write \$AA to the SWSR

Both writes must occur in the order listed prior to the SWT timeout, but any number of instructions or accesses to the SWSR can be executed between the two writes. This order allows interrupts and exceptions to occur, if necessary, between the two writes.

Caution should be exercised when changing system protection control register (SYPCR) values after the software watchdog timer (SWT) has been enabled with the setting of the SWE register bit, because it is difficult to determine the state of the SWT while the timer is running. The SWP and SWT[1:0] bits in SYPCR determine the SWT timeout period. The countdown value determined by the SWP and SWT[1:0] bits is constantly compared with that specified by these bits. Therefore, altering the contents of the SWP and SWT[1:0] bits improperly will result in unpredictable processor behavior. The following steps must be taken in order to change one of these values in the SYPCR:

Freescale Semiconductor, Inc.

System Protection And Reset Status

1. Disable SWT by writing a 0 to the SWE bit in SYPCR.
2. Service the SWSR, write \$55, then write \$AA to SWSR. This action resets the counter.
3. Re-write new SWT[1:0] and SWP values to SYPCR register.
4. Re-enable SWT by writing a 1 to SWE bit in SYPCR. Users can perform this task in Step 3.

9.5.2.1 System Protection Control Register

The SYPCR controls the software watchdog timer, timeout periods, and software watchdog timer transfer acknowledge.

The SYPCR is an 8-bit read-write register. The register can be read at any time, but can be written only if $\overline{\text{SWT IRQ}}$ is not pending. At system reset, the software watchdog timer is disabled.

Table 9-27 System Protection Control Register (SYPCR)

BITS	7	6	5	4	3	2	1	0
FIELD	SWE1	SWRI	SWP	SWT[1]	SWT[0]	SWTA	SWTAVAL	—
RESET	0	0	0	0	0	0	0	
R/W	R/W	R/W	R/W	R/W	R/W	R/W	R/W	
ADDR	MBAR + \$(0X01)							

Table 9-28 System Protection Control Bit Descriptions

BIT NAME	DESCRIPTION
SWE	Software Watchdog Enable 0 = SWT disabled 1 = SWT enabled
SWRI	Software Watchdog Reset/Interrupt Select 0 = If SWT timeout occurs, SWT generates an interrupt to the core processor at the level programmed into the IL bits of ICR0. 1 = SWT causes soft reset to be asserted for all modules of the part.
SWP	Software Watchdog Prescaler 0 = SWT clock not prescaled 1 = SWT clock prescaled by a value of 8192
SWT[1:0]	The Software Watchdog Timing Delay bits (along with the SWP bit) select the timeout period for the SWT as shown in Table 9-29 . At system reset, the software watchdog timer is set to the minimum timeout period.

Table 9-29 SWT Timeout Period

SWP	SWT[1:0]	SWT TIMEOUT PERIOD
0	00	2^9 / System Frequency
0	01	2^{11} / System Frequency

Table 9-29 SWT Timeout Period (Continued)

SWP	SWT[1:0]	SWT TIMEOUT PERIOD
0	10	2 ¹³ / System Frequency
0	11	2 ¹⁵ / System Frequency
1	00	2 ²² / System Frequency
1	01	2 ²⁴ / System Frequency
1	10	2 ²⁶ / System Frequency
1	11	2 ²⁸ / System Frequency

Note: If the SWP and SWT bits are modified to select a new software timeout, users must perform the software service sequence (\$55 followed by \$AA written to the SWSR) before the new timeout period takes effect.

Table 9-30 SWP and SWT Bit Descriptions

BIT NAME	DESCRIPTION
SWTA	Software Watchdog Transfer Acknowledge Enable 0 = SWTA Transfer Acknowledge disabled 1 = SWTA Assert Transfer Acknowledge enabled. After 1 SWT timeout period of the unacknowledged assertion of the SWT interrupt, the Software Watchdog Transfer Acknowledge will assert, which allows SWT to terminate a bus cycle and allow the IACK to occur
SWTAVAL	Software Watchdog Transfer Acknowledge Valid 0 = SWTA Transfer Acknowledge has NOT occurred 1 = SWTA Transfer Acknowledge has occurred. Write a 1 to clear this flag bit

9.5.2.2 Software Watchdog Interrupt Vector Register

The SWIVR contains the 8-bit interrupt vector the SIM returns during an interrupt-acknowledge cycle in response to a SWT-generated interrupt. The following register illustrates the SWIVR programming model.

The SWIVR is an 8-bit supervisor write-only register. This register is set to the uninitialized vector \$0F at system reset

Table 9-31 Software Watchdog Interrupt Vector Register (SWIVR)

BITS	7	6	5	4	3	2	1	0
FIELD	SWIV7	SWIV6	SWIV5	SWIV4	SWIV3	SWIV2	SWIV1	SWIV0
RESET	0	0	0	0	1	1	1	1
R/W	R/W	R/W	R/W	R/W	R/W	R/W	R/W	R/W
ADDR	MBAR + \$(0X02)							

9.5.2.3 Software Watchdog Service Register

The SWSR is where the SWT servicing sequence should be written. To prevent an SWT timeout, users should write a \$55 followed by a \$AA to this register. Both writes must be performed in the order listed prior to the SWT timeout, but any number of instructions or accesses to the SWSR can be executed between the two writes. If the SWT has already timed out, writing to this register will have no effect in negating the SWT interrupt. The following register illustrates the SWSR programming model.

The SWSR is an 8-bit write-only register. At system reset, the contents of SWSR are uninitialized.

Table 9-32 Software Watchdog Service Register (SWSR)

BITS	7	6	5	4	3	2	1	0
FIELD	SWSR7	SWSR6	SWSR5	SWSR4	SWSR3	SWSR2	SWSR1	SWSR0
RESET	-	-	-	-	-	-	-	-
R/W	R/W	R/W	R/W	R/W	R/W	R/W	R/W	R/W
ADDR	MBAR + \$(0X03)							

9.6 CPU STOP INSTRUCTION

Executing the CPU STOP instruction does not stop any of the clocks.

9.7 MCF5249 BUS ARBITRATION CONTROL

9.7.1 DEFAULT BUS MASTER PARK REGISTER

The MPARK determines the default bus master arbitration between internal transfers. This arbitration is needed because there are two bus masters inside the MCF5249. One is the CPU, the other is the DMA unit. Both can access internal registers within the MCF5249 peripherals. [Table 9-33](#) shows the MPARK register bit encoding.

The MPARK is an 8-bit read-write register.

Table 9-33 Default Bus Master Register (MPARK)

BITS	7	6	5	4	3	2	1	0
FIELD	PARK[1]	PARK[0]	IARBCTRL	EARBCTRL	SHOWDATA	-	-	BCR24BIT
RESET	0	0	0	0	0	0	0	0
R/W	R/W	R/W	R/W	R/W	R/W			R/W
ADDR	MBAR + \$(0X0C)							

9.7.1.1 Internal Arbitration Operation

The PARK[1:0] bits are programmed to indicate the priority of internal transfers within MCF5249 resources. The possible masters that can initiate internal transfers internal to the MCF5249 are the core and the on-chip DMAs. Since the priority between DMAs is resolved by their relative priority amongst each other and by programming the BWC bits in their respective DMA control registers (see [14.4.5 DMA Control Register](#)), the MPARK bits need only arbitrate priority between the core and the DMA module (which contains all four DMA channels) for internally generated transfers.

There are four arbitration schemes that the MPARK[1:0] bits can be programmed to with respect to internally generated transfers. The following summarizes these schemes when EARBCTRL=0:

1. Round Robin Scheme (PARK[1:0]=00)-- In this scenario, depending on which master has priority in the current transfer, the other master has priority in the next transfer once the current master finishes. When the processor is initialized, the core has first priority. So for example, if the core is the bus master and is finishing a bus transfer and DMA channels 0 and 1 (both set to BWC=010) are asserting an internal bus request signal, then the DMA channel 0 would gain ownership of the bus after the core; but after channel_0 finishes its transfer, the core would have ownership of the bus if its request was asserted.

Note: The Internal DMA has higher priority than the ColdFire Core if the internal DMA has its bandwidth BWC[2:0] bits set to 000 (maximum bandwidth).

2. Park on Master Core Priority (PARK[1:0]=01) -- Any time arbitration is occurring or the bus is idle, the core has priority. The DMA module can arbitrate a transfer only when the core's internal bus request signal is negated.
3. Park on Master DMA Priority (PARK[1:0]=10) -- Any time arbitration is occurring or the bus is idle, the DMA has priority. The core can arbitrate a transfer only when the DMA's internal bus request signal is negated.
4. Park on Current Master Priority (PARK[1:0]=11)-- Whatever the current master is, they have priority. Only when the bus is idle can the other master gain ownership and priority of the bus. For example, if out of reset the core has priority it will continue to have priority until the bus becomes idle, and the DMA asserts its internal bus request signal. At this point the DMA module has priority

9.7.1.2 PARK Register Bit Configuration

The following tables show the encoding for the PARK[1:0] bit of the MPARK register along with the priority schemes for each encoding.

Table 9-34 Default Bus Master Selected with PARK[1:0]

PARK[1:0]	DEFAULT BUS MASTER NUMBER
00	Round Robin between DMA and ColdFire Core
01	Park on master ColdFire Core
10	Park on master DMA Module
11	Park on current master

Table 9-35 Round Robin (PARK[1:0] = 00)

CURRENT HIGHEST PRIORITY MASTER	CURRENT LOWEST PRIORITY MASTER	NEXT ARBITRATION CYCLE HIGHEST PRIORITY MASTER	NEXT ARBITRATION CYCLE LOWEST PRIORITY MASTER
Core	DMA	DMA	Core
DMA	Core	Core	DMA

Table 9-35 shows the round robin configuration of internal module arbitration. Depending on which master has current ownership of the bus (i.e. has highest priority), the next arbitration cycle will switch priority to master that had lowest priority on that prior current cycle.

Table 9-36 Park on Master Core Priority (PARK[1:0] = 01)

PRIORITY	BUS MASTER NAME
Highest	ColdFire Core
Lowest	Internal DMA

Park on Master Core Priority (PARK[1:0] = 01)

PRIORITY	BUS MASTER NAME
Highest	Internal DMA
Lowest	ColdFire Core

Table 9-37 Park on Current Master Priority (PARK[1:0] = 11)

CURRENT HIGHEST PRIORITY MASTER	CURRENT LOWEST PRIORITY MASTER	NEXT ARBITRATION CYCLE HIGHEST PRIORITY MASTER	NEXT ARBITRATION CYCLE LOWEST PRIORITY MASTER
Core	DMA	Core	DMA
DMA	Core	DMA	Core

Note: When using the park on current master setting, the first master to arbitrate for the bus becomes the current master. The corresponding priority scheme should be interpreted as the priority of the next master once the current master finishes.

Table 9-38 Park Bit Descriptions

BIT NAME	DESCRIPTION
IARBCTRL	Legacy bit. 0 = Normal use 1 = do not use
EARBCTRL	Legacy bit. 0 = Normal use 1 = do not use
SHOWDATA	Enable this bit to drive internal register data bus to external bus. The EARBCTRL bit must be set to 1 for this function to work. 0 = Do not drive internal register data bus values to external bus 1 = Drive internal register data bus values to external bus

Table 9-38 Park Bit Descriptions (Continued)

BIT NAME	DESCRIPTION
BCR24BIT	<p>This bit controls the BCR and address mapping for the DMA. The bit allows the byte count register to be used as a 24-bit register. See Section 14 DMA Controller Module for memory maps and bit positions for the BCRs.</p> <p>0 = DMA BCRs function as 16-bit counters. 1 = DMA BCRs function as 24-bit counters.</p>

9.8 GENERAL PURPOSE I/Os

The MCF5249 has a total of 64 general purpose input and output functions defined. Two groups of 32-bit registers control these GPIOs.

Table 9-39 GPIO Registers

ADDRESS	NAME	WIDTH	DESCRIPTION	RESET VALUE	ACCESS
MBAR2 + \$0x000	GPIO-READ	32	gpio input value		R
MBAR2 + \$0x004	GPIO-OUT	32	gpio output value	0	R/W
MBAR2 + \$0x008	GPIO-EN	32	output enable	0	R/W
MBAR2 + \$0x00C	GPIO-FUNCTION	32	function select	0	R/W
MBAR2 + \$0x0B0	GPIO1-READ	32	gpio input value		R
MBAR2 + \$0x0B4	GPIO1-OUT	32	gpio output value	0	R/W
MBAR2 + \$0x0B8	GPIO1-EN	32	output enable	0	R/W
MBAR2 + \$0x0BC	GPIO1-FUNCTION	32	function select	0	R/W
MBAR2 + \$0x0C0	GPIO-INT-STAT	32	interrupt status		R
MBAR2 + \$0x0C0	GPIO-INT-CLEAR	32	interrupt clear		W
MBAR2 + \$0x0C4	GPIO-INT-EN	32	interrupt enable	0	R/W

9.8.1 GENERAL PURPOSE INPUTS

There are 64 defined general purpose input bits. They can be read in registers GPIO-READ and GPIO-READ1. These bits reflect the logical value of the pin they are associated with. The GPIO-READ and GPIO-READ1 registers always reflect the pin values, independent of the settings in the GPIO-FUNCTION, GPIO-EN, GPIO1-FUNCTION and GPIO1-EN registers. It does not matter if the pin is driving data out, or is being driven. The GPIO-READ and GPIO-READ1 bit to pin association is detailed in [Table 9-40](#).

Table 9-40 General Purpose Input to Pin Mapping

GENERAL PURPOSE INPUT	READ FROM PIN
GPIO-READ(31)	CTS2_B/ADIN3/GPI31
GPIO-READ(30)	CTS1_B/GPI30
GPIO-READ(29)	QSPI_CS0/GPIO29
GPIO-READ(28)	RXD2/ADIN2/GPI28
GPIO-READ(27)	RXD1/GPI27
GPIO-READ(26)	QSPI_DOUT/GPIO26
GPIO-READ(25)	SDATA01/GPIO25
GPIO-READ(24) ¹	QSPI_CS1/GPIO24 ¹
GPIO-READ(23)	TIN1/GPIO23
GPIO-READ(22) ¹	QSPI_CS3/GPIO22 ¹
GPIO-READ(21)	QSPI_CS2/GPIO21
GPIO-READ(20)	TA/GPIO20
GPIO-READ(19)	EF/GPIO19
GPIO-READ(18)	CFLG/GPIO18
GPIO-READ(17) ¹	BUFENB2/GPIO17 ¹
GPIO-READ(16)	IDE_IORDY/GPIO16
GPIO-READ(15)	SCLK_OUT/GPIO15
GPIO-READ(14)	IDE_DIOW/GPIO14
GPIO-READ(13)	CS2/IDE_DIOR/GPIO13
GPIO-READ(12) ¹	SWE/GPIO12 ¹
GPIO-READ(11) ¹	CS3/SRE/GPIO11 ¹
GPIO-READ(10)	BCLK/GPIO10
GPIO-READ(9)	SDATA1_BS1/GPIO9
GPIO-READ(8)	
GPIO-READ(7) ¹	SDRAM_CS2/GPIO7 ¹
GPIO-READ(6)	GPIO6
GPIO-READ(5)	GPIO5
GPIO-READ(4)	DDATA3/GPIO4
GPIO-READ(3)	SCL2/GPIO3
GPIO-READ(2)	DDATA2/GPIO2
GPIO-READ(1)	DDATA1/GPIO1
GPIO-READ(0)	DDATA0/GPIO0

GENERAL PURPOSE INPUT	READ FROM PIN
GPIO1-READ(63)	
GPIO1-READ(62)	PST3/GPIO62
GPIO1-READ(61)	PST2/GPIO61
GPIO1-READ(60)	PST1/GPIO60
GPIO1-READ(59)	PST0/GPIO59
GPIO1-READ(58)	CS1/GPIO58
GPIO1-READ(57)	BUFENB1/GPIO57
GPIO1-READ(56)	SDATA3/GPIO56
GPIO1-READ(55)	SDA2/GPIO55
GPIO1-READ(54) ¹	SDATA0_SDIO1/GPI O54 ¹
GPIO1-READ(53) ¹	SUBR/GPIO53 ¹
GPIO1-READ(52)	SFSY/GPIO52
GPIO1-READ(51) ¹	RCK/GPIO51 ¹
GPIO1-READ(50)	SCLK4/GPIO50
GPIO1-READ(49) ¹	SCLK3/GPIO49 ¹
GPIO1-READ(48)	SCLK2/GPIO48
GPIO1-READ(47)	
GPIO1-READ(46)	LRCK4/GPIO46
GPIO1-READ(45) ¹	LRCK3/GPIO45 ¹
GPIO1-READ(44)	LRCK2/GPIO44
GPIO1-READ(43)	
GPIO1-READ(42)	SDATAI4/GPI42
GPIO1-READ(41)	SDATAI3/GPI41
GPIO1-READ(40)	
GPIO1-READ(39)	EBUIN4/ADIN1/GPI39
GPIO1-READ(38)	EBUIN3/ADIN0/GPI38
GPIO1-READ(37)	EBUIN2/GPI37
GPIO1-READ(36)	EBUIN1/GPI36
GPIO1-READ(35)	
GPIO1-READ(34) ¹	CMD_SDIO2/GPIO34
GPIO1-READ(33)	TIN0/GPI33
GPIO1-READ(32)	

Note: The CMD_SDIO2, SDATA0_SDIO1, RSTO/SDATA2_BS2, A25, QSPI_CS1, QSPI_CS3, SDRAM_CS2, EBUOUT2, BUFENB2, SUBR, SFSY, RCK, SRE, LRCK3, SWE, and the SCLK3 signals are only used in the 160 MAPBGA package.

Note: MCLK1 and MCLK2 will output a clock signal just after reset and before they can be configured as GPIO if so desired. The frequency of the clock will be the same as CRIN prior to initialization of the PLL.

Note: EBUOUT1 and EBUOUT2 will output a clock signal just after reset and before they can be configured as GPIO. The frequency of the clock output will be CRIN/16.

All four pins can still be used for GPIO. The user needs to ensure that, when one of these four pins is assigned as a GPIO control within the system, the use will not cause the application to exhibit problems when the clock is active just after reset and before the boot code sets them to GPIO mode, e.g., do not use these pins to switch a critical circuit on/off.

9.8.1.1 General Purpose Input Interrupts

Eight general purpose inputs, those associated with GPIO-READ(7:0), have interrupt capability. On every low-to-high edge of these inputs, one of the bits 0-7 of register GPIO-INT-STAT is set. On every high-to-low edge of the inputs, one of the bits 8-15 is set. Clear is done by writing a '1' to the corresponding bit in GPIO-INT-CLEAR register. If any bit in GPIO-INT-STAT is set, and the corresponding bit in GPIO-INT-EN is set, an interrupt will be made pending on the secondary interrupt controller.

The registers GPIO-INT-STAT, GPIO-INT-CLEAR and GPIO-INT-EN also control some audio interrupts.

Set the GPIO_FUNCTION register bit to 1 or 0 for interrupts, as applicable.

Table 9-41 GPIO-INT-STAT, GPIO-INT-CLEAR and GPIO-INT-EN Interrupts

EVENT	GPIO-INT-STAT, GPIO-INT-CLEAR, GPIO-INT-EN BIT NUMBER	SECONDARY INTERRUPT CONTROLLER NUMBER
GPI0 L-H	0	32
GPI1 L-H	1	33
GPI2 L-H	2	34
GPI3 L-H	3	35
GPI4 L-H	4	36
GPI5 L-H	5	37
GPI6 L-H	6	38
GPI7 L-H	7	39
GPI0 H-L	8	32
GPI1 H-L	9	33
GPI2 H-L	10	34
GPI3 H-L	11	35
GPI4 H-L	12	36
GPI5 H-L	13	37
GPI6 H-L	14	38
GPI7 H-L	15	39
CD-ROM DECODER NEWBLOCK	16	56

Table 9-41 GPIO-INT-STAT, GPIO-INT-CLEAR and GPIO-INT-EN Interrupts (Continued)

EVENT	GPIO-INT-STAT, GPIO-INT-CLEAR, GPIO-INT-EN BIT NUMBER	SECONDARY INTERRUPT CONTROLLER NUMBER
CD-ROM DECODER ILSYNC	17	55
CD-ROM DECODER NOSYNC	18	54
CD-ROM DECODER CRCERROR	19	53
CD-ROM ENCODER NEWBLOCK	20	56
CD-ROM ENCODER ILSYNC	21	55
CD-ROM ENCODER NOSYNC	22	54
reserved	23	-

9.8.2 GENERAL PURPOSE OUTPUTS

There are 64 defined general purpose output bits. They are controlled by registers GPIO-OUT, GPIO-EN, GPIO-FUNCTION, GPIO1-OUT, GPIO1-EN and GPIO1-FUNCTION. Three bits are needed to control a single general-purpose output. As an example, the logic that drives pin DDATA3/GPIO34 is shown in [Figure 9-2](#) Whether the output function of the pin is the primary DDATA3 function or general-purpose output 34, is controlled by bit GPIO1-FUNCTION[2].

At power-on, the function is always the primary function. When a '0' is programmed in any bit of GPIO-FUNCTION or GPIO1-FUNCTION, the corresponding pin gets its primary function. In this case, output drive strength and output value are determined by the primary function logic. When a '1' is programmed in GPIO-FUNCTION or GPIO1-FUNCTION, the corresponding pin gets its gpo-function.

When a pin is in GPIO-mode, drive direction is determined by value in GPIO-EN or GPIO1-EN. When a '0' is programmed in any bit, the corresponding pin is driven to high-impedance state. When a '1' is programmed, the corresponding pin is driven low or high.

When a pin is in GPIO-mode, and being driven low-impedance, the actual drive value of the pin is determined by what is programmed in the corresponding bit of registers GPIO-OUT or GPIO1-OUT. If '0' is programmed here, the pin is driven low. If '1' is programmed, the pin is driven high.

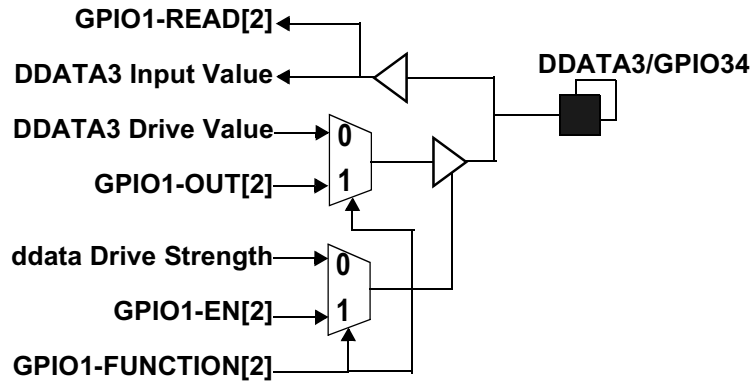

Figure 9-2 General-Purpose Pin Logic for Pin ddata3/gpio34

Table 9-42 General-Purpose Output Register Bits to Pins Mapping

GPIO-FUNCTION GPIO-EN GPIO-OUT BIT NUMBER	ASSOCIATED PIN	PIN TYPE	GPIO1-FUNCTION GPIO1-EN GPIO1-OUT BIT NUMBER	ASSOCIATED PIN	PIN TYPE
31	RTS2_B/GPO31	O	63	PSTCLK/GPO63	O
30	RTS1_B/GPO30	O	62	PST3/GPIO62	I/O
29	QSPI_CS0/GPIO29	I/O	61	PST2/GPIO61	I/O
28	TXD2/GPO28	O	60	PST1/GPIO60	I/O
27	TXD1/GPO27	O	59	PST0/GPIO59	I/O
26	QSPI_DOUT/GPIO26	I/O	58	CS1/GPIO58	I/O
25	SDATA01/GPIO25	I/O	57	BUFENB1/GPIO57	I/O
24	QSPI_CS1/GPIO24	I/O	56	SDATA3/GPIO56	I/O
23	TIN1/GPIO23	I/O	55	SDA2/GPIO55	I/O
22	QSPI_CS3/GPIO22	I/O	54	SDATA0_SDIO1/GPI O54	I/O
21	QSPI_CS2/GPIO21	I/O	53	SUBR/GPIO53	I/O
20	TA/GPIO20	I/O	52	SFSY/GPIO52	I/O
19	EF/GPIO19	I/O	51	RCK/GPIO51	I/O
18	CFLG/GPIO18	I/O	50	SCLK4/GPIO50	I/O
17	BUFENB2/GPIO17	I/O	49	SCLK3/GPIO49	I/O
16	IDE_IORDY/GPIO16	I/O	48	SCLK2/GPIO48	I/O
15	SCLK_OUT/GPIO15	I/O	47		
14	IDE_DIOW/GPIO14	I/O	46	LRCK4/GPIO46	I/O
13	CS2/IDE_DIOR/GPIO13	I/O	45	LRCK3/GPIO45	I/O
12	SWE/GPIO12	I/O	44	LRCK2/GPIO44	I/O

Table 9-42 General-Purpose Output Register Bits to Pins Mapping (Continued)

GPIO-FUNCTION GPIO-EN GPIO-OUT BIT NUMBER	ASSOCIATED PIN	PIN TYPE	GPIO1-FUNCTION GPIO1-EN GPIO1-OUT BIT NUMBER	ASSOCIATED PIN	PIN TYPE
11	CS3/SRE/GPIO11	I/O	43		
10	BCLK/GPIO10	I/O	42	MCLK2/GPO42	O
9	SDATA1_BS1/GPIO9	I/O	41	SDATAO2/GPO41	O
8	A25/GPO8	O	40		
7	SDRAM_CS2/GPIO7	I/O	39	MCLK1/GPO39	O
6	GPIO6	I/O	38	XTRIM/GPO38	O
5	GPIO5	I/O	37	EBUOUT2/GPO37	O
4	DDATA3/GPIO4	I/O	36	EBUOUT1/GPO36	O
3	SCL2/GPIO3	I/O	35	TOUT1/ADOUT/GPO 35	O
2	DDATA2/GPIO2	I/O	34	CMD_SDIO2/GPIO3 4	I/O
1	DDATA1/GPIO1	I/O	33	TOUT0/GPO33	O
0	DDATA0/GPIO0	I/O	32		

Note: The CMD_SDIO2, SDATA0_SDIO1, RSTO/SDATA2_BS2, A25, QSPI_CS1, QSPI_CS3, SDRAM_CS2, EBUOUT2, BUFENB2, SUBR, SFSY, RCK, SRE, LRCK3, SWE, and the SCLK3 signals are only used in the 160 MAPBGA package.

Note: Some pins associated with the general-purpose outputs are output-only. (Denoted with "O" in column "Pin Type"). These pins can be tri-stated. If an '0' is written in the corresponding bit of GPIO-EN or GPIO1-EN, the pin is driven to high-impedance state.

Section 10

Chip-Select Module

10.1 INTRODUCTION

The Chip Select Module provides user-programmable control of the four chip select outputs, two buffer enable outputs and one output-enable signal.

This section describes the operation and programming model of the chip-select (CS) registers, including the chip select address, mask, and control registers.

10.1.1 CHIP SELECT FEATURES

- Four programmable chip select signals
- IORDY and TA handshake pins
- Two programmable buffers enable signals for glueless interface to bus buffers
- Address masking for memory block sizes from 64KBytes to 4GBytes
- Programmable wait states
- Port size is 16 bits

10.2 CHIP-SELECT SIGNALS

The MCF5249 provides four programmable chip selects that can directly interface with SRAM, EPROM, EEPROM, and peripherals. Two of these chip selects are usable for AT-bus peripherals that need separate read and write strobe, and use IORDY signalling to insert wait states.

10.2.1 CHIP SELECTS

10.2.1.1 $\overline{\text{CS0}}$

CS0 is the first chip select and it addresses the boot memory. (A ROM or flash memory device.) At power-on reset, all bus cycles are mapped to the CS0. This allows the boot memory to be defined at any address space. CS0 is the only chip select initialized at reset.

10.2.1.2 $\overline{\text{CS1}}$ /GPIO1

CS1 is the second chip select and it can be programmed for an address location as well as for masking, port size and burst capability indication, wait state generation, and internal/external termination. A reset clears all chip select programming

10.2.1.3 $\overline{\text{CS2}}$ /IDE- $\overline{\text{DIOR}}$ /GPIO13 AND IDE- $\overline{\text{DIOW}}$ /GPIO14

These two signals go active during $\overline{\text{CS2}}$ cycles. IDE- $\overline{\text{DIOR}}$ can be programmed to go active on read and write cycles, or IDE- $\overline{\text{DIOR}}$ can be programmed to go active only on read cycles, and IDE- $\overline{\text{DIOW}}$ only on write cycles. It has identical features as the normal $\overline{\text{CS2}}$. It can be programmed for an address location as well as for masking, port size and burst capability indication, wait state generation, and internal/external termination.

$\overline{\text{IDE-DIOR}}$ and $\overline{\text{IDE-DIOW}}$ can also be used as enables to access an IDE drive or another AT-bus peripheral. This added functionality allows users to insert more than 16 wait states on $\overline{\text{IDE-DIOR}}$, $\overline{\text{IDE-DIOW}}$, and allows dynamic cycle termination using the IORDY signal.

10.2.1.4 $\overline{\text{CS3/SRE/GPIO11}}$ AND $\overline{\text{SWE/GPIO12}}$

These two signals go active during $\overline{\text{CS3}}$ cycles. $\overline{\text{SRE}}$ can be programmed to go active on read and write cycles, or $\overline{\text{SRE}}$ can be programmed to go active only on read cycles, and $\overline{\text{SWE}}$ only on write cycles. It has identical features as the normal CS3. It can be programmed for an address location as well as for masking, port size and burst capability indication, wait state generation, and internal/external termination.

Note: The SWE and SRE signals are only used on the 160 MAPBGA package.

$\overline{\text{SRE}}$ and $\overline{\text{SWE}}$ can also be used as enables to access an IDE drive or another AT-bus peripheral. This added functionality allows users to insert more than 16 wait states on $\overline{\text{SRE}}$, $\overline{\text{SWE}}$, and allows dynamic cycle termination using the IORDY signal.

10.2.2 OUTPUT ENABLE $\overline{\text{OE/GPIO9}}$

The $\overline{\text{OE/GPIO9}}$ signal interfaces memory and/or peripherals to enable a read transfer. It is asserted and negated on the falling edge of the clock. This signal is asserted only when there is a match of one of the chip selects for the current address decode.

10.2.3 BUFFER ENABLE SIGNALS - BUFENB1 AND BUFENB2

The BUFENB1/GPIO57 and BUFENB2/GPIO17 signals are intended to enable bus buffers sitting between some chip select modules and the MCF5249 bus. BUFENB1 is always active on $\overline{\text{CS0}}$, BUFENB2 is always inactive on $\overline{\text{CS0}}$. It is programmable if the bus buffer signals go active on $\overline{\text{CS1}}$, $\overline{\text{CS2}}$, and $\overline{\text{CS3}}$.

Note: The BUFENB2 signal is only used in the 160 MAPBGA package.

10.2.4 IORDY - BUS TERMINATION SIGNAL

The IORDY signal controls the insertion of wait states on the third and fourth chip select.

10.3 MCF5249CHIP-SELECT OPERATION

10.3.1 CHIP-SELECT MODULE

The chip select module provides a glueless interface to many types of external memory. The module contains the necessary external control signals to interface to SRAM, PROM, EPROM, EEPROM, FLASH and peripherals.

Some features of the chip selects are controlled by the IDECONFIG1 and IDECONFIG2 registers. These are described in [Section 10.4](#).

Each of the four chip select outputs has an associated mask register and control register.

Chip selects ($\overline{CS}0$, $\overline{CS}1$ /GPIO1, \overline{DIOR} / \overline{DIOW} (CS2), \overline{SRE} / \overline{SWE} (CS3)):

- Each has a 16-bit base address register.
- Each has a 32-bit mask register, which provides 16-bit address masking and access control.
- Each has a 16-bit control register, which provides port size and burst capability indication, wait state generation, and automatic acknowledge generation features.

Note: The SWE and SRE signals are only used on the 160 MAPBGA package.

Chip select 0 provides special functionality. It is a “global” chip select after reset and provides relocatable boot ROM capability.

In addition to the 2 external chip select outputs, the module contains 2 chip selects (CS2 and CS3) for use with AT-bus peripherals such as IDE drives and Flash Card interfaces. Capabilities for CS2 and CS3 are like CS1, but there are some enhancements for typical AT-bus features. The enhancements are described in [Section 10.4](#).

10.3.1.1 GENERAL CHIP SELECT OPERATION

The general-purpose chip selects are controlled by the chip select mask register (CSMR), the chip select control register (CSCR), and by the chip select address register (CSAR). There is one CSAR, CSMR, and CSCR for each of the chip selects ($\overline{CS}0$ – $\overline{CS}3$).

Chip Selects ($\overline{CS}[3:0]$):

- The chip select address register controls the base address space of the chip select.
- The chip select mask register controls the memory block size and addressing attributes of the chip select.
- The chip select control register programs the features of the chip select signals.

The MCF5249 processor compares the address and mask in $\overline{CS}[3:0]$ control registers. If the address and attributes do not match in a single chip select register, the cycle will terminate in error. [Table 10-1](#) shows the type of access depending on what matches are made in the CS control registers.

Table 10-1 Accesses by Matches in CS Control Registers

NUMBER OF CHIP SELECTS REGISTER MATCHES	TYPE OF ACCESS
None	Error ¹
Single	As defined by chip select control register
Multiple	External ^{2,3}
<p>Note 1: The cycle will not terminate, and the bus will hang. Watchdog timer may recover from hung bus.</p> <p>Note 2: External termination by pulling the TA pin low is required. Glueless interface with memory is not possible. If TA pin is not pulled low, cycle will not terminate causing the bus to hang.</p> <p>Note 3: For the case of multiple chip selects matching, all of the matching chip selects will be asserted.</p>	

10.3.1.1.1 PORT SIZING

The MCF5249 only supports a 16-wide port size (PS). The size of the port controlled by a chip-select is programmable. The port size is specified by the (PS) bits in the chip select control register (CSCR). It should always be programmed as a 16-wide port. See [Section 10.4.2.3](#) for details.

10.3.2 GLOBAL CHIP-SELECT OPERATION

$\overline{CS0}$ is the global (boot) chip select and it allows address decoding for the boot ROM before system initialization occurs. Its operation differs from the other external chip-select outputs following a system reset.

After system reset, $\overline{CS0}$ is asserted for every external access. Internal accesses can be made to go external by setting the internal bus arbitration control (IARBCTRL) bit of the default bus master (MPARK) register in the system integration module (SIM). No other chip-select can be used while $\overline{CS0}$ is a global chip select. $\overline{CS0}$ operates in this manner until the valid bit is set in chip select mask register CSMR0[0], at which point $\overline{CS1}$ may be used. At reset, the port size and automatic acknowledge functions of the global chip-select are determined.

The reset value is always auto-acknowledge (AA) with 15 wait states, and the port size bits (PS[1:0]) in CSCR0 are set to "10", 16 bit port.

Provided the required address range is first loaded into chip select address register (CSAR), $\overline{CS0}$ can be programmed to continue to decode for a range of addresses after the valid (V) bit is set. After the V-bit is set for $\overline{CS0}$, global chip-select can be restored only with another system reset.

10.4 PROGRAMMING MODEL

10.4.1 CHIP-SELECT REGISTERS MEMORY MAP

[Table 10-2](#) shows the memory map of all the chip-select registers. Reading reserved locations returns zeros.

Similarly, the CSCRs should be accessed through a MOV.L to longword address offset they belong to, while reading and writing to the lower 16-bits of the longword data transfer (DATA[15:0]).

Note: All of these accesses are longword in length, instead of word length, even though both the CSARs and CSCRs use only 16 bits in the 32-bits registers.

Table 10-2 Memory Map of Chip-Select Registers

ADDRESS	NAME	WIDTH	DESCRIPTION	RESET VALUE ²	ACCESS ³
MBAR + 0x80	CSAR 0	16	Chip-Select Address Register–Bank 0	uninitialized	R/W
MBAR + 0x84	CSMR 0	32	Chip-Select Mask Register–Bank 0	uninitialized (except V = 0)	R/W
MBAR + 0x88	CSCR 0	16	Chip-Select Control Register–Bank 0	BEM = 1; BSTR = BSTW = 0; AA = 1; PS1 = 1; PS0 = 0; WS3 = WS2 = WS1 = WS0 = 1	R/W
MBAR + 0x8C	CSAR 1	16	Chip-Select Address Register–Bank 1	uninitialized	R/W
MBAR + 0x90	CSMR 1	32	Chip-Select Mask Register–Bank 1	uninitialized (except V = 0)	R/W
MBAR + 0x94	CSCR 1	16	Chip-Select Control Register–Bank 1	uninitialized	R/W
MBAR + 0x98	CSAR 2	16	Chip-Select Address Register–IDE	uninitialized	R/W
MBAR + 0x9C	CSMR 2	32	Chip-Select Mask Register–IDE	uninitialized (except V = 0)	R/W
MBAR + 0xA2	CSCR 2	16	Chip-Select Control Register–IDE	uninitialized	R/W
MBAR + 0xA4	CSAR 3	16	Chip-Select Address Register–FC	uninitialized	R/W
MBAR + 0xA8	CSMR 3	32	Chip-Select Mask Register–FC	uninitialized (except V = 0)	R/W
MBAR + 0xAE	CSCR 3	16	Chip-Select Control Register–FC	uninitialized	R/W

Note 1: Addresses not assigned to a register and undefined register bits are reserved for future expansion. Write accesses to these reserved address spaces and reserved register bits are undefined.

Note 2: The reset value column indicates the register initial value at reset. Certain registers may be uninitialized upon reset, (they could contain random values.)

Note 3: The access column indicates whether the corresponding register allows both read/write functionality (R/W), read-only functionality (R), or write-only functionality (W). A read access to a write-only register will return zeros. A write access to a read-only register will have no effect.

10.4.2 CHIP SELECT MODULE REGISTERS

The various chip select registers in the module are described as follows.

10.4.2.1 CHIP SELECT ADDRESS REGISTER

CSAR0 and CSAR1 determine the base address of the corresponding chip select pin, and are read/writable. CSAR2 and CSAR3 determine the base address of the IDE and Flash Card interfaces.

- These read/write registers are 32-bit in length. The value stored in each CSAR register corresponds to A[31:16].
- These registers are uninitialized by reset.

Table 10-4 shows the bit assignment for the base address.

Table 10-3 Chip Select Address Register (CSAR)

BITS	31	30	29	28	27	26	25	24	23	22	21	20	19	18	17	16
FIELD	BA3 1	BA3 0	BA2 9	BA2 8	BA2 7	BA2 6	BA2 5	BA2 4	BA2 3	BA2 2	BA2 1	BA2 0	BA1 9	BA1 8	BA1 7	BA1 6
RESET	—	—	—	—	—	—	—	—	—	—	—	—	—	—	—	—
R/W	R/W	R/W	R/W	R/W	R/W	R/W	R/W	R/W	R/W	R/W	R/W	R/W	R/W	R/W	R/W	R/W
BITS	15	14	13	12	11	10	9	8	7	6	5	4	3	2	1	0
FIELD	—	—	—	—	—	—	—	—	—	—	—	—	—	—	—	—
RESET	—	—	—	—	—	—	—	—	—	—	—	—	—	—	—	—
R/W																
MBAR (0X80), MBAR (0X8C), MBAR (0X98), MBAR (0XA4),																

Table 10-4 Chip Select Bit Descriptions

BIT NAME	DESCRIPTION
BA[31:16]	The Base Address field defines the base address location of memory dedicated to chip select $\overline{CS}[3:0]$. These bits are compared to bits 31–16 on the internal core address bus to determine if the chip select memory is being accessed.

10.4.2.2 CHIP SELECT MASK REGISTER

The chip select mask registers CSMR0 to CSMR3 are readable and writable. They determine the address mask for $\overline{CS}0$, $\overline{CS}1$, DIOR/DIOW, SRE/SWE, respectively. In addition, CSMR[3:0] determines which type of access is allowed for these signals. Each CSMR is a 32-bit read/write control register that physically resides in the chip select module. With the exception of bit 0 (V-bit), which is initialized to 0 on reset, all other bits in CSMR[3:0] are uninitialized by reset. The CSMR is illustrated in the following table.

Note: The SWE and SRE signals are only used on the 160 MAPBGA package.

Table 10-5 Chip Select Mask Register (CSMR)

BITS	31	30	29	28	27	26	25	24	23	22	21	20	19	18	17	16
FIELD	BAM 31	BAM 30	BAM 29	BAM 28	BAM 27	BAM 26	BAM 25	BAM 24	BAM 23	BAM 22	BAM 21	BAM 20	BAM 19	BAM 18	BAM 17	BAM 16
RESET	—	—	—	—	—	—	—	—	—	—	—	—	—	—	—	—
R/W	R/W	R/W	R/W	R/W	R/W	R/W	R/W	R/W	R/W	R/W	R/W	R/W	R/W	R/W	R/W	R/W
BITS	15	14	13	12	11	10	9	8	7	6	5	4	3	2	1	0
FIELD	—	—	—	—	—	—	—	WP	—	AM	C/I	SC	SD	UC	UD	V
RESET	—	—	—	—	—	—	—	—	—	—	—	—	—	—	—	0
R/W																
MBAR (0 X 84), MBAR (0 X 90), MBAR (0 X 9C), MBAR (0 X A8),																

Table 10-6 Chip Select Mask Bit Descriptions

BIT NAME	DESCRIPTION
BAM [31:16]	<p>The Base Address Mask field defines the chip select block size through the use of address mask bits. Any set bit masks the corresponding base address register (CSAR) bit (the base address bit becomes a don't care in the decode).</p> <p>0 = Corresponding address bit is used in chip select decode 1 = Corresponding address bit is a don't care in chip select decode</p> <p>The block size for $\overline{CS}[3:0]$ is equal to 2^n, where $n = (\text{number of bits set in the base address mask field of the respective CSMR}) + 16$.</p> <p>For example, if CSAR0 were set at \$0000 and CSMR0 were set at \$0008, then chip select CS0 would address two discontinuous memory blocks of 64 KBytes each: the first block would be from \$00000000 to \$0000FFFF and the second block would be from \$00080000 to \$0008FFFF. Stated another way, if any of the upper 16-bits in the CSMR0 were set, then the corresponding address bit is a don't care in the chip select decode.</p> <p>Another example might be if CS0 were to access 32 MBytes of address space starting at location \$0 and CS1 has to begin at the next byte after CS0 for an address space of 16MB. Then:</p> <p>CSAR0 = \$0000, (upper 16 bits of) CSMR0 = \$01FF, and CSAR1 = \$0200, (upper 16 bits of) CSMR1 = \$00FF.</p>
Address Space Mask Bits	

Table 10-6 Chip Select Mask Bit Descriptions (Continued)

BIT NAME	DESCRIPTION
WP, AM, C/I, SC, SD, UC, UD	<p>These fields mask specific address spaces, placing the chip select in a specific address space or spaces. If an address space mask bit were cleared, an access to a location in that address space can activate the corresponding chip select. If an address space mask bit were set, an access to a location in that address space becomes a regular external bus access, and no chip select is activated.</p> <p>AM: alternate master access (DMA) C/I: interrupt cycle access SC: Supervisor code access SD: supervisor data access UC: user code access UD: user data access</p> <p>For each address space mask bit (AM, C/I, SC, SD, UC, UD):</p> <p>0 = Do not mask this address space for the chip select. An access using the chip select can occur for this address space. 1 = Mask this address space from the chip select activation. If this address space is accessed, no chip select activation occurs on the external cycle.</p>
WP	<p>The Write Protect bit can restrict write accesses to the address range in a CSAR. An attempt to write to the range of addresses specified in a CSAR that has this bit set results in the appropriate chip select not being selected. No exception occurs.</p> <p>0 = Both read and write accesses are allowed. 1 = Only read access is allowed.</p>
AM	<p>The Alternate Master bit indicates if alternate master (DMA) access is allowed or denied</p> <p>0 = Alternate master access is allowed 1 = Alternate master access is denied</p>
V	<p>The Valid bit indicates that the contents of its address register, mask register, and control register are valid. The programmed chip selects do not assert until the V-bit is set (except for $\overline{CS0}$ which acts as the global (boot) chip select—see Section 10.3.2).</p> <p>A reset clears the V-bit in each CSMR.</p> <p>0 = Chip select invalid 1 = Chip select valid</p>

10.4.2.3 CHIP SELECT CONTROL REGISTER

CSCR0 to CSCR3 control the auto acknowledge, external master support, port size, burst capability, and activation of each of the chip selects.

For CSCR0, bits BSTR, and BSTW are initialized to 0 by reset; bits WS[3:0] and BEM are initialized to 1 by reset; while AA, PS1, and PS0 are loaded with “110”, respectively at reset. For CSCR1 to CSCR3 none of the bits are initialized at reset. These are shown in Tables [Table 10-7](#) and [Table 10-8](#).

Table 10-7 Chip Select Control Register 0

BITS	15	14	13	12	11	10	9	8	7	6	5	4	3	2	1	0
FIELD	—	—	WS3	WS2	WS1	WS0	—	AA	PS1	PS0	—	BSTR	BSTW	—	—	—
RESET	—	—	1	1	1	1	—	1	1	0	—	0	0	—	—	0
R/W			R/W	R/W	R/W	R/W		R/W	R/W	R/W	R/W	R/W	R/W			R/W
MBAR (0 X 8A)																

Table 10-8 Chip Select Control Register 1 to 3

BITS	15	14	13	12	11	10	9	8	7	6	5	4	3	2	1	0
FIELD	—	—	WS3	WS2	WS1	WS0	—	AA	PS1	PS0		BSTR	BSTW	—	—	—
RESET	—	—	—	—	—	—	—	—	—	—	—	—	—	—	—	0
R/W			R/W	R/W	R/W	R/W		R/W	R/W	R/W	R/W	R/W	R/W			R/W
MBAR (0 X 96), MBAR (0 X A2), MBAR (0 X AE)																

$\overline{CS0}$ is the global (boot) chip select which allows address decoding for boot ROM before system initialization occurs. Its operation differs from the other external chip select outputs following a system reset.

Table 10-9 Chip Select Bit Descriptions

BIT NAME	DESCRIPTION
WS[3:0]	The Wait States field defines the number of wait states that are inserted before an internal transfer acknowledge is generated. If the AA bit is cleared, \overline{TA} must be asserted by the external system regardless of the number of wait states generated.
BSTR	The Burst Read Enable field specifies whether burst reads are used for the memory associated with each chip select. 0 = Breaks data larger than the specified port size into individual non-burst reads that equals the specified port size. For example, a longword read from an 16-bit port would be broken into two individual wordreads. 1 = Enables burst read of data larger than the specified port size.
BSTW	The Burst Write Enable field specifies whether burst writes are used for the memory associated with each chip select. 0 = Break data larger than the specified port size into individual non-burst writes that equals the specified port size. For example, a longword write to an 16-bit port would be broken into two individual word writes. 1 = Enables burst write of data larger than the specified port size.

Table 10-9 Chip Select Bit Descriptions (Continued)

BIT NAME	DESCRIPTION
AA	<p>The Auto-Acknowledge Enable field determines the assertion of the internal transfer-acknowledge for accesses specified by the chip select address.</p> <p>0 = No internal transfer acknowledge (\overline{TA}) is asserted. 1 = Internal acknowledge (\overline{TA}) is asserted as specified by WS[3:0].</p>
PS[1:0]	<p>The Port Size field specifies the width of the data associated with each chip select. It determines where data is driven during write cycles and where data is sampled during read cycles. Port size should always be programmed to 16 bits for MCF5249.</p> <p>00 = reserved 01 = 8-bit port size 10 = 16-bit port size—Data sampled and driven on D[31:16] only 11 = 16-bit port size—Data sampled and driven on D[31:16] only</p> <p>Note: A0 is not available on the external bus.</p>

10.4.2.4 CODE EXAMPLE

The following code provides an example of how to initialize the chip- selects.

```

CSAR0 EQU MBARx+$080;Chip Select 0 address register
CSMR0 EQU MBARx+$084;Chip Select 0 mask register
CSCR0 EQU MBARx+$088;Chip Select 0 control register

CSAR1 EQU MBARx+$08C;Chip Select 1 address register
CSMR1 EQU MBARx+$090;Chip Select 1 mask register
CSCR1 EQU MBARx+$094;Chip Select 1 control register

; All other chip selects should be programmed and made valid before global
; chip select is de-activated by validating CS0
; Program Chip Select 1 Registers

move.l#$00000000,D0;CSAR1 base addresses $00000000 (to $001FFFFF)
move.ID0,CSAR1;and $80000000 (to $801FFFFF)

move.l#$000009B0,D0;CSCR1 = 2 wait states, AA=1, PS=16-bit, BEM=1,
move.ID0,CSCR1;BSTR=1, BSTW=0

move.l#$801F0001,D0;Address range from $00000000 to $001FFFFF and
move.ID0,CSMR1;$80000000 to $801FFFFF
;WP,EM,C/I,SC,SD,UC,UD=0, V=1

;Program Chip Select 0 Registers
move.l#$00800000,D0;CSAR0 base address $00800000 (to $009FFFFF)
move.ID0,CSAR0

move.l#$00000D80,D0;CSCR0 = 3 wait states, AA=1, PS=16-bit, BEM=0,
move.ID0,CSCR0;BSTR=0, BSTW=0

; Program Chip Select 0 Mask Register (validate chip selects)
move.l#$001F0001,D0;Address range from $00800000 to $009FFFFF
move.ID0,CSMR0;WP,EM,C/I,SC,SD,UC,UD=0; V=1
    
```

Section 11

Timer Module

11.1 TIMER MODULE OVERVIEW

This section describes the configuration and operation of the two general purpose timer modules (timer0 and timer1).

The timer module incorporates two independent, general purpose 16-bit timers, timer0 and timer1. The output of an 8-bit prescaler clocks each 16-bit timer. The prescaler input can be the system clock, the system clock divided by 16, or the timer input (TIN) pin. [Figure 11-1](#) is a block diagram of the timer module.

The two timer input pins and two timer output pins are multiplexed with GPIO pins. Upon reset, they are all programmed as timer pins.

Note: The maximum system clock is 1/2 the CPU clock.

11.2 TIMER FEATURES

Each of the general purpose 16-bit timers provide the following features:

- Maximum period of 3.8 seconds at 70 MHz.
- 14.28 ns minimum resolution at 70 MHz system clock
- Programmable sources for the clock input, including external clock
- Input-capture capability with programmable trigger edge on input pin
- Output-compare with programmable mode for the output pin
- Free run and restart modes
- Maskable interrupts on input capture or reference-compare

11.3 TIMER SIGNALS

This section describes the signals utilized in the Timer Module.

11.3.1 TIMER INPUTS

The timer input pins TIN0/GPI33 and TIN1/GPIO23 are multiplexed with general purpose inputs. At reset, the function is timer input.

11.3.2 TIMER OUTPUTS

The timer output pins TOUT0/GPO33 and TOUT1/GPO35 are multiplexed with general purpose outputs. At reset, the function is timer output.

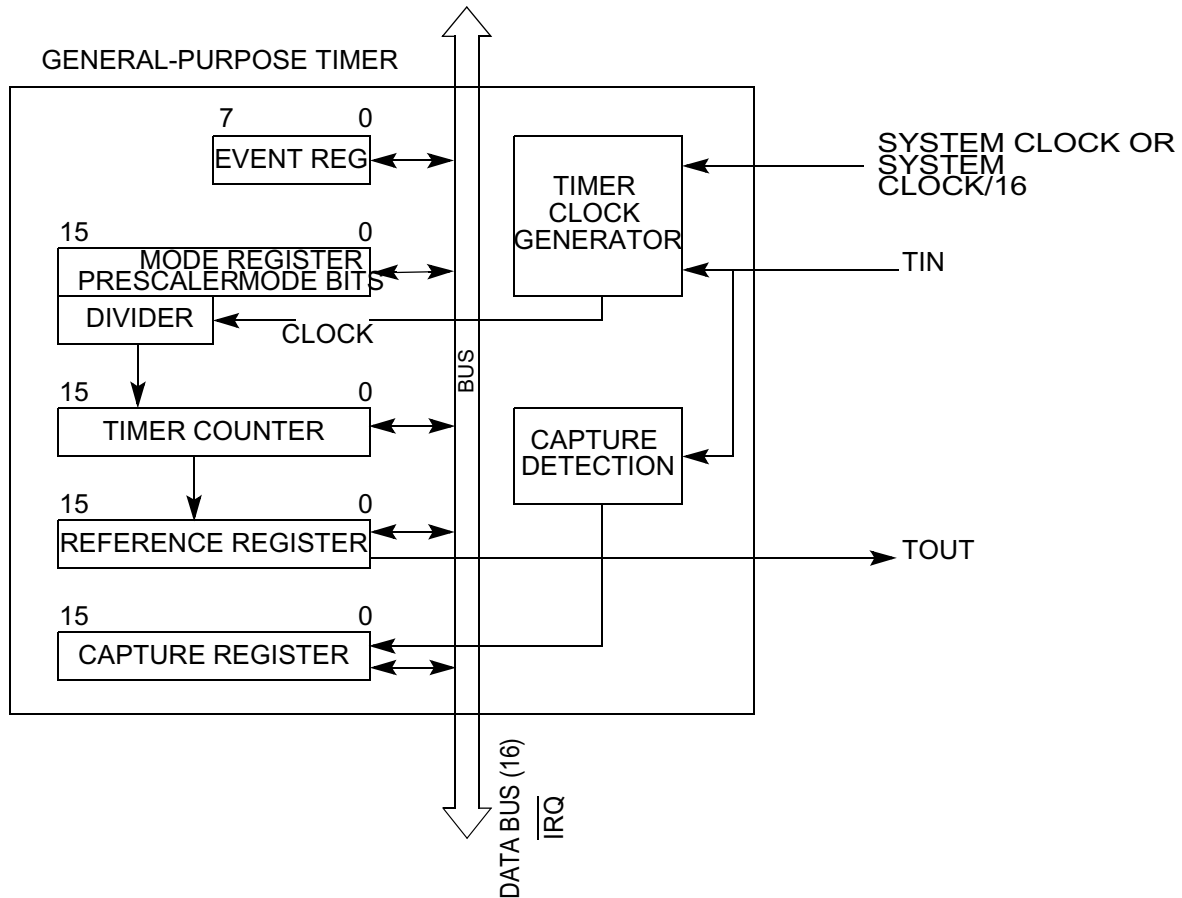

Figure 11-1 Timer Block Diagram Module Operation

11.4 GENERAL-PURPOSE TIMER UNITS

The general-purpose timer units provide the following features:

- Users can program timers to count and compare to a reference value stored in a register or capture the timer value at an edge detected on the TIN pin
- An 8-bit prescaler output clocks the timers
- Users can program the prescaler clock input
- Programmed events generate interrupts
- Users can configure the TOUT pin to toggle or pulse on an event

The minimum resolution of each timer is one system clock cycle (14.28 ns at 70 MHz). The maximum timeout period $(16 \times 256 \times 65536) / 70 \text{MHz} = 3.83$ seconds. ($\$0 - \$FFFF = 65536$ decimal.)

11.4.1 SELECTING THE PRESCALER

Users can select the prescaler clock from the main clock (divided by 1 or by 16) or from the corresponding timer input TIN pin. TIN is synchronized to the internal clock. The synchronization delay is between two and three main clocks. TIN must meet the setup time spec shown in [Table 21-10](#) in Section 21.

The CLK bits of the corresponding Timer Mode Register (TMR) select the clock input source. The prescaler is programmed to divide the clock input by values from 1 to 256. The prescaler output is used as an input to the 16-bit counter.

11.4.2 CAPTURE MODE

The timer has a 16-bit Timer Capture Register (TCR) that latches the counter value when the corresponding input capture-edge detector senses a defined transition of TIN. The capture edge (CE) bits in the TMR select the type of transition triggering the capture. A capture event sets the CAP bit in the Timer Event Register (TER) and issues a maskable interrupt.

11.4.3 CONFIGURING THE TIMER FOR REFERENCE COMPARE

Users can configure the timer to count until it reaches a reference value at which time it either starts a new time count immediately or continues to run. The free run/restart (FRR) bit of the TMR selects either mode. When the timer reaches the reference value, the REF bit in the TER register is set and issues an interrupt if the output reference interrupt (ORI) enable bit in TMR is set.

11.4.4 CONFIGURING THE TIMER FOR OUTPUT MODE

The timer can send an output signal on the timer output (TOUT) pin when it reaches the reference value as selected by the output mode (OM) bit in the TMR. This signal can be an active-low pulse or a toggle of the current output under program control.

11.5 GENERAL-PURPOSE TIMER REGISTERS

Users can modify the timer registers at any time. [Table 11-1](#) shows the timer programming model.

Table 11-1 Programming Model for Timers

TIMER 0 ADDRESS	TIMER 1 ADDRESS	TIMER MODULE REGISTERS	
MBAR+\$140	MBAR+\$180	Timer Mode Register (TMRn)	
MBAR+\$144	MBAR+\$184	Timer Reference Register (TRRn)	
MBAR+\$148	MBAR+\$188	Timer Capture Register (TCRn)	
MBAR+\$14C	MBAR+\$18C	Timer Counter (TCNn)	
MBAR+\$151	MBAR+\$191	Reserved	Timer Event Register (TERn)

11.5.1 TIMER MODE REGISTERS (TMR0, TMR1)

The TMR is a 16-bit memory-mapped register. This register programs the various timer modes and is cleared by reset.

Table 11-2 Timer Mode Register (TMRn)

BITS	15	14	13	12	11	10	9	8	7	6	5	4	3	2	1	0
FIELD	PRESCALER VALUE (PS7 - PS0)								CE1 - CE0		OM	ORI	FRR	CLK1 - CLK0		RESET
RESET	0	0	0	0	0	0	0	0	0	0	0	0	0	0	0	0
R/W	READ/WRITE SUPERVISOR OR USER MODE															
ADDR	MBAR+\$140, MBAR+\$180															

Table 11-3 Timer Mode Bit Descriptions

BIT NAME	DESCRIPTION
PS7–PS0	The Prescaler Value is programmed to divide the clock input by values from 1 to 256. The value 00000000 divides the clock by 1; the value 11111111 divides the clock by 256. Prescaler value = $2^{[PS7 - PS0]}$
CE1–CE0	Capture Edge and Enable Interrupt 11 = Capture on any edge and enable interrupt on capture event 10 = Capture on falling edge only and enable interrupt on capture event 01 = Capture on rising edge only and enable interrupt on capture event 00 = Disable interrupt on capture event
OM	Output Mode 1 = Toggle output 0 = Active-low pulse for one system clock cycle (14.28 ns at 70 MHz)
ORI	Output Reference Interrupt Enable 1 = Enable interrupt upon reaching the reference value 0 = Disable interrupt for reference reached (does not affect interrupt on capture function) Note: If ORI is set when the REF event is asserted in the Timer Event Register (TER), an immediate interrupt occurs. If ORI is cleared while an interrupt is asserted, the interrupt negates.
FRR	Free Run/Restart 1 = Restart: Timer count is reset immediately after reaching the reference value 0 = Free run: Timer count continues to increment after reaching the reference value

Table 11-3 Timer Mode Bit Descriptions (Continued)

BIT NAME	DESCRIPTION
CLK1–CLK0	Input Clock Source for the Timer 11 = TIN pin (falling edge) 10 = Master system clock divided by 16. Note: The clock source is synchronized with the timer. However, the divider is not reset to 0 when the timer is stopped, thus successive time-outs may vary slightly in length. 01 = Master system clock 00 = Stops counter. After the counter is stopped, the value in the Timer Counter (TCN) register remains constant.
RST	The Reset Timer bit performs a software timer reset identical to that of an external reset. All timer registers take on their corresponding reset values. While this bit is zero, the other register values can still be written, if necessary. A transition of this bit from one to zero is what resets the register values. The counter/timer/prescaler is not clocked unless the timer is enabled. 1 = Enable timer 0 = Reset timer (software reset)

11.5.2 TIMER REFERENCE REGISTERS (TRR0, TRR1)

The TRR is a 16-bit register that contains the reference value that is compared with its respective, free-running timer counter (TCN), as part of the output-compare function. TRR is a memory-mapped read/write register.

TRR is set at reset. The reference value is not matched until TCN equals TRR, and the prescaler indicates that the TCN should be incremented again. Thus, the reference register is matched after (TRR+1) time intervals.

Table 11-4 Timer Reference Register (TRRn)

BITS	15	14	13	12	11	10	9	8	7	6	5	4	3	2	1	0
FIELD	16-BIT REFERENCE COMPARE VALUE REF15 - REF0															
RESET	1	1	1	1	1	1	1	1	1	1	1	1	1	1	1	1
R/W	READ/WRITE SUPERVISOR OR USER MODE															
ADDR	MBAR+\$144, MBAR+\$184															

11.5.3 TIMER CAPTURE REGISTERS (TCR0, TCR1)

The TCR is a 16-bit register that latches the value of the timer counter (TCN) during a capture operation when an edge occurs on the TIN pin, as programmed in the TMR. TCR appears as a memory-mapped read-only register and is cleared at reset.

Table 11-5 Timer Capture Register (TCR)

BITS	15	14	13	12	11	10	9	8	7	6	5	4	3	2	1	0
FIELD	16-BIT CAPTURE COUNTER VALUE CAP15 - CAP0															
RESET	0	0	0	0	0	0	0	0	0	0	0	0	0	0	0	0
R/W	READ ONLY SUPERVISOR OR USER MODE															
ADDR	MBAR+\$148, MBAR+\$188															

11.5.4 TIMER COUNTERS (TCN0, TCN1)

TCN is a memory-mapped 16-bit up counter that users can read at any time. A read cycle to TCN yields the current timer value and does not affect the counting operation.

A write of any value to TCN causes it to reset to all zeros.

Table 11-6 Timer Counter (TCN)

BITS	15	14	13	12	11	10	9	8	7	6	5	4	3	2	1	0
FIELD	16-BIT TIMER COUNTER VALUE COUNT15 - COUNT0															
RESET	0	0	0	0	0	0	0	0	0	0	0	0	0	0	0	0
R/W	READ/WRITE SUPERVISOR OR USER MODE															
ADDR	MBAR+\$14C, MBAR+\$18C															

11.5.5 TIMER EVENT REGISTERS (TER0, TER1)

The TER is an 8-bit register that reports events the timer recognizes. When the timer recognizes an event, it sets the appropriate bit in the TER, regardless of the corresponding interrupt-enable bits (ORI and CE) in the TMR.

TER appears as a memory-mapped register and can be read at any time.

Writing a one to a bit will clear it (writing a zero does not affect the bit value); more than one bit can be cleared at a time. The REF and CAP bits must be cleared before the timer will negate the IRQ to the interrupt controller. Reset clears this register.

Table 11-7 Timer Event Register (TERn)

BITS	7	6	5	4	3	2	1	0
FIELD	RESERVED READ AS 0						REF	CAP
RESET	0	0	0	0	0	0	0	0
R/W	READ/WRITE SUPERVISOR OR USER MODE							
ADDR	MBAR+\$151, MBAR+\$191							

Table 11-8 Timer Event Bit Descriptions

BIT NAME	DESCRIPTION
Bits 7–2	Reserved for future use. These bits are currently 0 when read.
CAP	If a one is read from the Capture Event bit, the counter value has been latched into the TCR. The CE bit in the TMR enables the interrupt request caused by this event. Writing a one to this bit will clear the event condition.
REF	If a one is read from the Output Reference Event bit, the counter has reached the TRR value. The ORI bit in the TMR enables the interrupt request caused by this event. Writing a one to this bit will clear the event condition.

11.5.6 TIMER INITIALIZATION EXAMPLE CODE

There are two timers on the MCF5249. With a 70MHz clock, the maximum period is 3.8 seconds and a resolution of 14.28 ns. The timers can be free running or count to a value and reset. The following examples set up the timers:

Timer 0 will count to \$AF AF, toggle its output, and reset back to \$0000. This will continue infinitely until the timer is disabled or a reset occurs. No interrupts are set. Prescale is set at 256 and the system clock is divided by 16, therefore resolution is $(16 \times (256)) / 70 \text{ MHz} = 58.51 \mu\text{s}$. Timeout period is $(16 \times 256 \times 44976) / 70 \text{ MHz} = 2.63 \text{ s}$ ($\$0 - \$AF AF = 44976$ decimal).

Timer 1 will be free-running and send out a logic pulse every time it compares the count value in the TRR register. value, which for now, is randomly chosen as \$1234. Prescale is set at 127 with the sys_clock initially divided by 16 (by setting bits 2&1 of the TMR register to 10 therefore, resolution is $(16 \times (127)) / 70 \text{ MHz} = 29 \mu\text{s}$. Interrupts are NOT enabled.

Note: The timers were initialized in the SIM to have interrupt values. The following examples have the interrupts disabled. The initialization in the SIM configuration was for reference. The Timers CANNOT provide interrupt vectors, only autovectors.

Autovectors and ICRs have been set up as follows. The interrupt levels and priorities were chosen by random for demonstrative purposes. Users should define the interrupt level and priorities for their specific application.

11.5.6.1 TIMER 0 (TIMER MODE REGISTER)

- Bits 15:8 sets the prescale to 256 (\$FF)
- Bits 7:6 set for no interrupt ("00")
- Bits 5:4 sets output mode for "toggle". No interrupts("10")
- Bits 3 set for "restart" ("1")
- Bits 2:1 set the clocking source to system clock/16 ("10")
- Bit 0 enables/disables the timer ("0")

```
move.w #$FF2C,D0;Setup the Timer mode register (TMR1)
```

Freescale Semiconductor, Inc.

General-Purpose Timer Registers

```
move.w D0,TMR1;;    Bit 1 is set to 0 to disable the timer
move.w #$0000,D0; writing to the timer counter with any value resets it to zero
move.w D0,TCN1;
```

11.5.6.2 TIMER 0 (TIMER REFERENCE REGISTER 0)

The TRR register is set to \$AFAF. The timer will count up to this value (TCN = TRR), toggle the “TOUT” pin, and reset the TCN to \$0000.

```
move.w #$AFAF,D0;Setup the Timer reference register (TRR1)
move.w D0,TRR1
```

Other registers used for TIMER 0

TCR1;TIMER1 Capture Register, 16-bit, R

TER1;TIMER1 Event Register, 8-bit, R/W

11.5.6.3 TIMER 1 (TIMER MODE REGISTER 1)

Bits 15:8 set the prescale to 127 (\$7F)

Bits 7:6 set the capture mode and interrupt (“00”)

Bits 5:4 set the output mode for “pulse” and no interrupt (“00”)

Bits 3 set for free-running (“0”)

Bits 2:1 set the clocking source to clk/16 (“10”)

Bit 1 enables the timer (“0”)

```
move.w #$7F04,D0;Setup the Timer mode register (TMR2)
move.w D0,TMR2;
```

```
move.w #$1234,D0;Set the Timer reference to $1234
move.w D0,TRR2;
```

```
move.w #$0000,D0;writing to the timer counter with
move.w D0,TCN2;    any value resets it to zero
```

Other registers used:

TCR2;TIMER1 Capture Register, 16-bit, R

TER2;TIMER1 Event Register, 8-bit, R/W

Section 12

Analog to Digital Converter (ADC)

12.1 ADC OVERVIEW

The ADC functionality is based on the Sigma-Delta concept using 12-bit resolution. The ADC uses four muxed inputs with the following pin names.

1. EBUIN3_ADIN0_GPI38
2. EBUIN4_ADIN1_GPI39
3. RXD2_ADIN2_GPI28
4. CTS2_ADIN3_GPI31

The digital portion of the ADC is internal while the analog voltage comparator must be provided from an external source.

The single output on the TOUT1_ADOUT_GPO35 pin provides the reference voltage in PWM format therefore this output requires an external integrator circuit (resistor/capacitor) to convert it to a DC level to be used by the external comparator circuit. A circuit example is shown below.

Only one input can be converted at any one time. The input to be converted is selected via the source select bits (8 + 9) of the ADconfig Register.

A software interrupt can be provided when the ADC measurement cycle is complete. Interrupt can be disabled.

Note: ADC functionality is shared with EBUIN3 and EBUIN4, UART1 (RXD and CTS), and TOUT1.

12.2 ADC FUNCTIONALITY

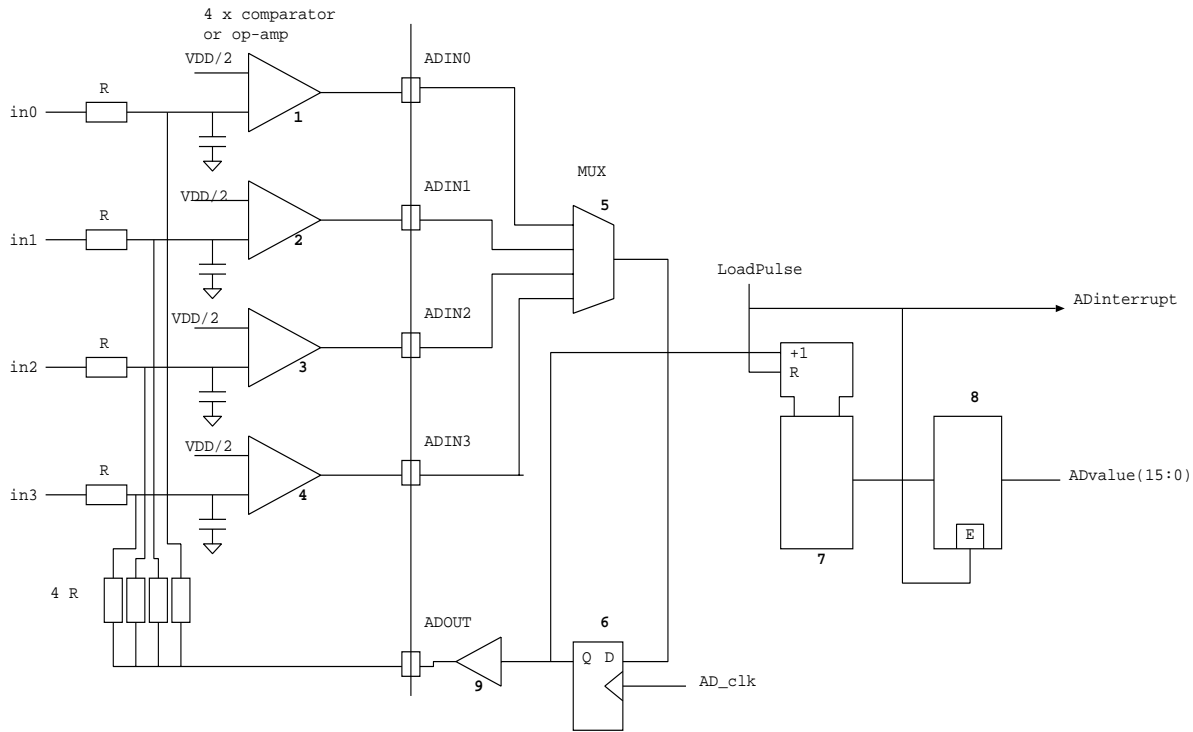

Figure 12-1 ADC with On-chip and External Parts

Table 12-1 ADC Registers

ADDRESS MBAR2BAS +	NAME	WIDT H	DESCRIPTION	RESET VALUE	ACCES S
0x402	ADconfig	16	AD configuration		RW
0x406	ADvalue	16	AD measurement result		R

The ADC uses the sigma-delta modulation principle. The ADC external components are external comparators. See Figure 12-1, VDD/2-1 for channel 1. One input of the comparator connects to Vdd/2, the other input connects to a capacitor that integrates the charge. The integrated charge is proportional to the voltage on input *in0*, and on the average duty cycle on device pin *ADOUT*.

As shown in Figure 12-1, the MCF5249 selects one of the four inputs using the mux. The *ADOUT* value is calculated using the flip-flop and the buffer. The feed-back loop keeps the voltage on the capacitor close to VDD/2. In this way, the voltage on input *in0* is proportional to the duty cycle of the signal on *ADOUT*.

The circuit measures the duty cycle of the *ADOUT* signal. Every time *ADOUT* is high, the counter increments. At the 4096th *AD_CLK* clock pulse value, the counter is latched into the register and *ADInterrupt* is generated. The counter is then reset.

On reception of *ADInterrupt*, the MCF5249 reads *ADvalue(11:0)* from *ADvalue* register. The value should be in the range 0-4096, which indicates the duty cycle of *ADOUT*.

Table 12-2 ADconfig (ADconfig) Register

BITS	15	14	13	12	11	10	9	8	7	6	5	4	3	2	1	0
FIELD	-	-	-	-	-	ADOUT_SE L	SOURCE SELECT	INT INTCLEAR	INTERRUP T ENABLE	ADOUT_DRIVE	ADCLK_SEL					
RESET	-	-	-	-	-	0	000	-	-	-	-	-	-	-	-	-
R/W	R/W															
Address MBAR2BAS + 0x402																

Table 12-3 ADconfig Register Bit Descriptions

FIELD	FIELD NAME	DESCRIPTION	RESET
10	ADOUT_SEL	1: TOUT1/GPO35/ADOUT pin function is ADOUT 0: TOUT1/GPO35/ADOUT pin function is not ADOUT	0
9:8	SOURCE SELECT	00: in0 01: in1 10: in2 11: in3	000
7	INT INTCLEAR	(On read): '1' indicates interrupt pending '0' no interrupt pending (On write): '1' clear interrupt '0' no action	
6	INTERRUPT ENABLE	0: interrupt disabled 1: interrupt enabled	
5:4	ADOUT_DRIVE	01: ADout tri-state 00: ADout drives +Vdd for Hi, GND for lo 11: ADout drives +Vdd for Hi, Hi-Z for lo 10: ADout drives Hi-Z for Hi, GND for lo	
3:0	ADCLK_SEL	0: adclk = busclk 1: adclk = busclk / 2 2: adclk = busclk / 4 3: adclk = busclk / 8 4: adclk = busclk / 16 5: adclk = busclk / 32 6: adclk = busclk / 64 7: adclk = busclk / 128 8: adclk = busclk / 256	

Note: 1. Measurement frequency and interrupt frequency is adclk / 4096

Note: 2. For the circuit shown [Figure 12-1](#), the adout_drive should be set to 00.
Other circuits can use settings 10 or 11.

Note: 3. AD resolution is 12 bits. AD precision depends on many factors, and is TBD.

Note: 4. Only one channel can be measured simultaneously.

Table 12-4 ADvalue Register

BITS	15	14	13	12	11	10	9	8	7	6	5	4	3	2	1	0
FIELD	-	-	-	-	ADVALUE											
RESET	-	-	-	-	-	-	-	-	-	-	-	-	-	-	-	-
R/W	R															
Address MBAR2BAS + 0x406																

Table 12-5 ADvalue Register Bit Descriptions

FIELD	FIELD NAME	DESCRIPTION	RESET
11:0	ADVALUE	AD measurement result	

Section 13

IDE and FlashMedia Interface

13.1 IDE AND SMARTMEDIA OVERVIEW

The MCF5249 device system bus allows connection of an IDE hard disk drive and SmartMedia flash card with a minimum of external hardware. The following block diagram shows the bus set-up for the MCF5249 device. The diagram includes an interface with an IDE device and a SmartMedia device.

Note: SmartMedia refers to Flash memory cards such as Compact Flash. For other Flashmedia such as Secure Digital (SD), MultiMedia Card (MMC) or Memory Stick, refer to [Section 13.4](#).

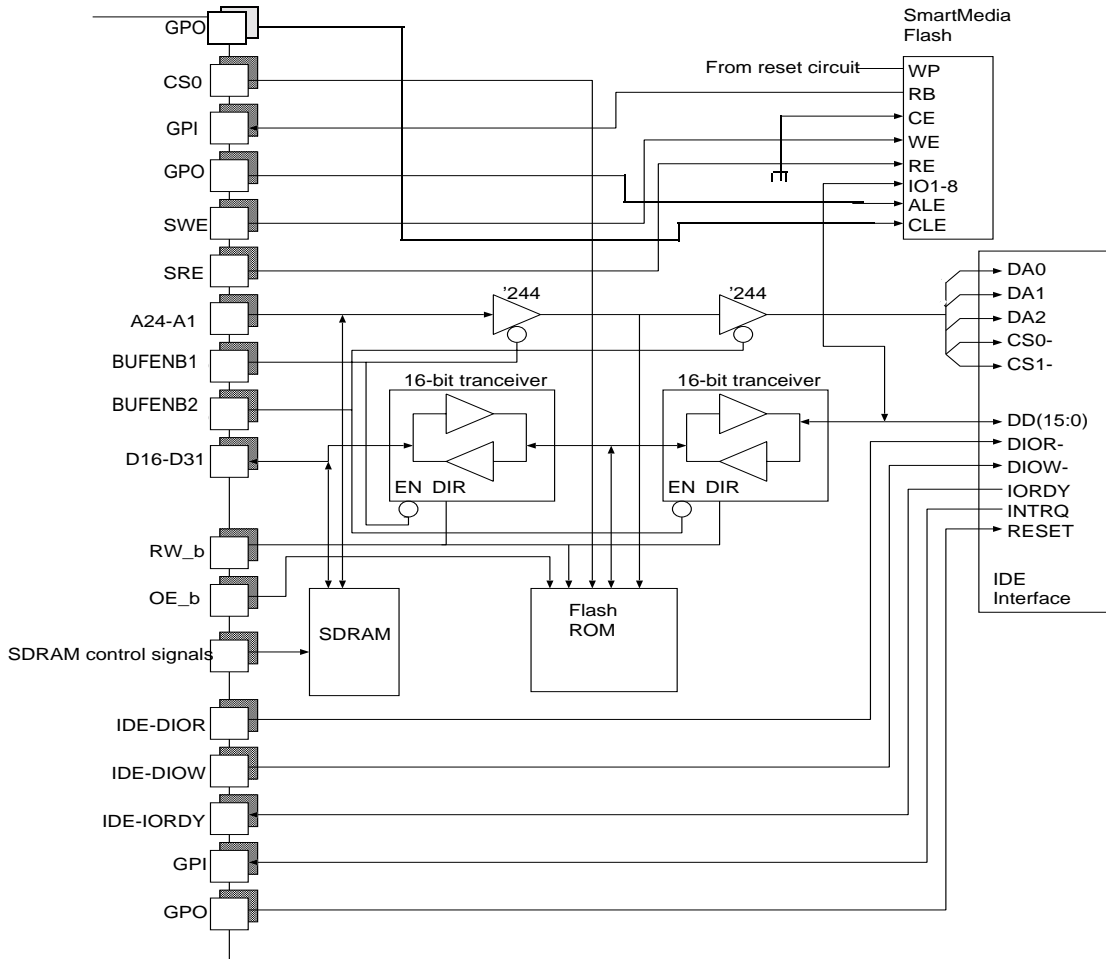

Figure 13-1 Bus Setup with IDE and SmartMedia Interface

There are two sets of buffers in this set-up. The SDRAM is connected directly to the ColdFire bus. The “first” bus buffer isolates the SDRAM bus from the flash ROM device. After the bus buffer, the flash

memory is connected. The IDE and SmartMedia interfaces share most signals with the ColdFire address and data bus. The “second” bus buffer prevents the flash ROM signals from going to/from IDE and SmartMedia interfaces.

To support this bus set-up, a number of signals are available.

- **BUFENB1**: active-low external buffer enable. This enable is always active when CS0 is active, and should enable a buffer going to the boot ROM.
- **BUFENB2**: active-low external buffer enable. This enable is always inactive when CS0 is active, and should enable a buffer for peripheral devices, except boot ROM.
- **IDE-DIOR, IDE-DIOW**: active-low IDE bus read and write strobe.
- **IDE-IORDY**: active-high “ready” indication from IDE device to MCF5249.
- **SRE, SWE**: active-low SmartMedia read and write strobe

Note: The SWE and SRE signals are only used on the 160 MAPBGA package.

The extra bus signals, and their configuration are detailed in the following section.

13.1.1 BUFFER ENABLES BUFENB1, BUFENB2, AND ASSOCIATED LOGIC.

Buffer enables *BUFENB1* and *BUFENB2* allow a seamless interface to external bus buffers. The buffers may be placed on the address and the data bus.

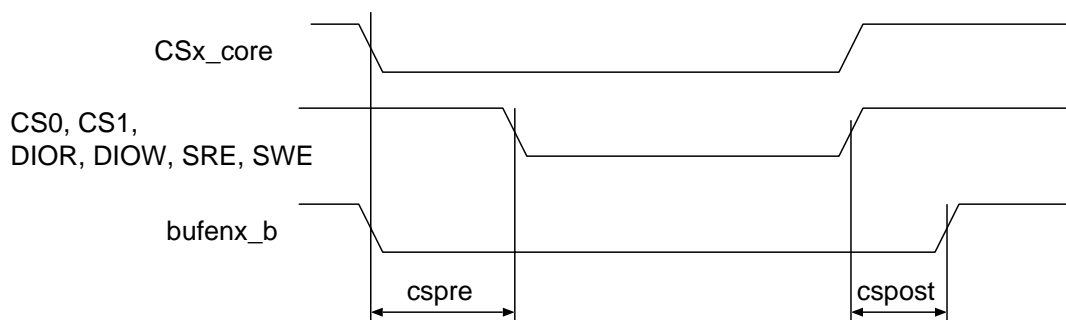

Figure 13-2 Buffer Enables (BUFENB1 and BUFENB2)

BUFENB1 is always active on CS0. BUFENB2 is never active on CS0. Either of the buffer enables can be programmed to be active on CS1, CS2, or CS3.

As shown in [Figure 13-2](#), the buffer enables BUFENB1 and BUFENB2 will go active at time *CSPRE* before the falling edge of the Chip Select signal, and continue to be active for a time *CSPOST* after the rising edge of the chip select signal. The pre-drive time *CSPRE* is realized by delaying the falling edge of the select signal. If pre-drive time *CSPRE* is programmed non-zero, and internal ColdFire cycle termination is used, chip select length will be *CSPRE* shorter than the programmed length. Times *CSPRE*, *CSPOST* are the same for both BUFENB1 AND BUFENB2. Times *CSPRE*, *CSPOST* are independently programmable for every select.

Buffer enable configuration is programmable using the IDE_CONFIG1 register.

Table 13-1 ideconfig1 Register

ADDRESS MBAR2BAS +	ACCESS	SIZE BITS	NAME	DESCRIPTION
MBAR2BAS+0x18c	RW	32	IDE CONFIG1	Configuration of buffer enable generation

Table 13-2 IDECONFIG1 Bits

IDE CONFIG1 BITS	FIELD NAME	MEANING	RES
2:0	CS0PRE	pre-drive for CS0 000: no predrive 001: 1 clock 010: 2 clocks 011: 3 clocks 100: 4 clocks 101: 5 clocks	0
4:3	CS0POST	post-drive for CS0 00: no post-drive 01: 1 clock post-drive 10: 2 clock post drive 11: 3 clock post drive	0
7:5	CS1PRE	pre-drive for CS1 000: no predrive 001: 1 clock 010: 2 clocks 011: 3 clocks 100: 4 clocks 101: 5 clocks	0
9:8	CS1POST	post-drive for CS1 00: no post-drive 01: 1 clock post-drive 10: 2 clock post drive 11: 3 clock post drive	0
12:10	CS2PRE	pre-drive for DIOR, DIOW 000: no predrive 001: 1 clock 010: 2 clocks 011: 3 clocks 100: 4 clocks 101: 5 clocks	0
14:13	CS2POST	post-drive for CS2 00: no post-drive 01: 1 clock post-drive 10: 2 clock post drive 11: 3 clock post drive	0
16	BUFEN1CS1 EN	0: bufen1 inactive on CS1 cycles 1: bufen1 active on CS1 cycles	0

Table 13-2 IDECONFIG1 Bits (Continued)

IDE CONFIG1 BITS	FIELD NAME	MEANING	RES
17	BUFEN1CS2 EN	0: bufen1 inactive on DIOR, DIOW cycles 1: bufen1 active on DIOR, DIOW cycles	0
18	BUFEN1CS3 EN	0: bufen1 inactive on SRE, SWE cycles 1: bufen1 active on SRE, SWE cycles	0
19	BUFEN2CS1 EN	0: bufen2 inactive on CS1 cycles 1: bufen2 active on CS1 cycles	0
20	BUFEN2CS2 EN	0: bufen2 inactive on DIOR, DIOW cycles 1: bufen2 active on DIOR, DIOW cycles	0
21	BUFEN2CS3 EN	0: bufen2 inactive on SRE, SWE cycles 1: bufen2 active on SRE, SWE cycles	0
24:22	CS3PRE	pre-drive for SRE, SWE 000: no predrive 001: 1 clock 010: 2 clocks 011: 3 clocks 100: 4 clocks 101: 5 clocks	0
26:25	CS3POST	post-drive for CS1 00: no post-drive 01: 1 clock post-drive 10: 2 clock post drive 11: 3 clock post drive	0
27	DIOR on write	0: DIOR not active during write cycles 1: DIOR active during write cycles	0
28	SRE active during write	0: SRE not active during write 1: SRE active during write	0

Note: The SWE and SRE signals are only used on the 160 MAPBGA package.

13.1.2 GENERATION OF IDE-DIOR, IDE-DIOW, SRE, SWE

These four signals are generated internally by gating the CS2_pin and CS3_pin signals with RWb. DIOR and DIOW are created by gating CS2_pin with RWb. SRE and SWE are created by gating CS3_pin with RWb.

Note: The SWE and SRE signals are only used on the 160 MAPBGA package.

DIOR and SRE are programmable if these signals go active on write cycles. If these signals are programmed to go active during write cycles, they can be used as extra chip enables. (CS2 and CS3).

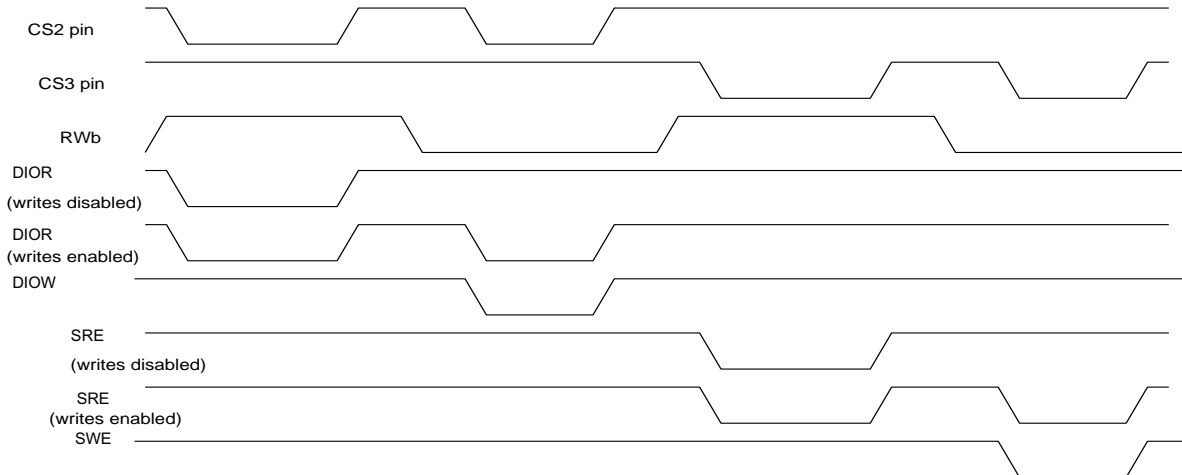

Figure 13-3 DIOR and SRE Timing Diagram

13.1.3 CYCLE TERMINATION ON CS2, CS3 (DIOR, DIOW, SRE, SWE)

Dedicated logic has been added to the MCF5249 to allow IDE compliant cycles on the bus. The logic can generate the transfer acknowledge (TA) signal for CS2 and CS3 accesses. The manner in which the TA signal is generated is programmable using the IDE config 2 register, and is compatible with IDE/SmartMedia requirements.

Note: The SWE and SRE signals are only used on the 160 MAPBGA package.

Table 13-3 IDEConfig Register

ADDRESS MBAR2BAS +	ACCESS	SIZE BITS	NAME	DESCRIPTION
MBAR2BAS +0x190	RW	32	IDE CONFIG2	Configuration of TA generation on CS2, CS3

Table 13-4 IDEConfig Bit Description

IDE CONFIG2 BITS	FIELD NAME	MEANING	RES
7:0	WAITCOUNT3	CS3 delay count. Controls TA timing for CS3	0
15:8	WAITCOUNT2	CS2 delay count. Controls TA timing for CS2	0
16	TA ENABLE 3	1: Generate TA for CS3 accesses 0: Do not generate TA for CS3	0
17	IORDY ENABLE 3	1: Allow IORDY to delay TA generation for CS3 0: do not look at IORDY for CS3 TA generation	0
18	TA ENABLE 2	1: Generate TA for CS2 accesses 0: Do not generate TA for CS2	0
19	IORDY ENABLE 2	1: Allow IORDY to delay TA generation for CS2 0: do not look at IORDY for CS2 TA generation	0

Freescale Semiconductor, Inc.

SmartMedia Interface Setup

The logic is identical for CS2 (DIOR, DIOW), and for CS3 (SRE, SWE). The timing diagram for a non-ioridy controlled IDE/SmartMedia TA generation is shown in Figure 13-4.



Figure 13-4 Non-IORDY Controlled IDE/SmartMedia TA Timing

The system also supports dynamic lengthening of CS2 (DIOR, DIOW) and CS3 (SRE, SWE) cycles using the IORDY signal. The timing diagram is shown in Figure 13-5.

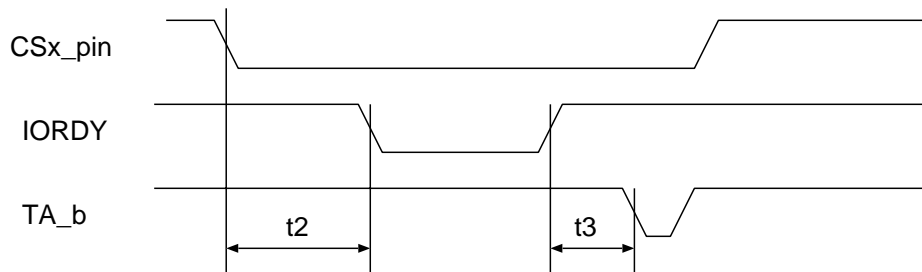

Figure 13-5 CS2 (DIOR, DIOW) and CS3 (SRE, SWE) Cycle Timing

Table 13-5 DIOR, DIOW, and IORDY Timing Parameters

TIMING PARAMETER	DESCRIPTION	MIN	TYP	MAX
t1	DIOR, DIOW low to TA SRE, SWE low to TA		(waitCount2 + 2.5)T (waitCount3 + 2.5)T	
t2	DIOR, DIOW low to IORDY low SRE, SWE low to IORDY low	0 0		(waitCount2 + 1.5)T (waitCount3 + 1.5)T
t3	IORDY high to TA	2T		3T

Note: t2 is relevant for IORDY controlled cycles only.

Note: The SWE and SRE signals are only used on the 160 MAPBGA package.

13.2 SMARTMEDIA INTERFACE SETUP

The SmartMedia block must be connected to the bus as follows:

- RE input connect to MCF5249 SRE output
- WE input connect to MCF5249 SWE output
- D0-7 connect to MCF5249 data bus wires 31-24
- CE connect to always low
- ALE connect to general purpose output
- CLE connect to general purpose output
- R/B connect to general purpose input

To set up the SmartMedia interface perform the following tasks.

1. Program the three Chip Select registers inside the chip select modules (CSAR3, CSMR3, CSCR3) as follows:
 - CSAR3, CSMR3 must be programmed to see the IDE interface in the correct part of the ColdFire address map.
 - CSCR3 bit fields must be programmed as follows:
 - AA: 0 (TA signal generated by IDEconfig2 register logic)
 - WS[3:0]: not relevant
 - PS[1:0]: 01 (8 bit port size)
 - BSTR, BSTW: 00 (no burst read/write cycles)
2. Program the IDE config1 register. Only fields *CS2PRE*, *CS2POST*, *BUFEN1CS2EN*, *BUFEN2CS2EN*, and *SRE active during write* are relevant. The values required for the buffer enable signals *BUFEN1CS2EN* and *BUFEN2CS2EN* depend on the hardware configuration. If two buffers are used in cascade, both bits must be 1. Fields *CS2PRE* and *CS2POST* are relevant and are detailed later in this section.
3. Program the IDE config2 register as follows:
 - *TA enable 3* = '1'
 - *IORDY enable 3* = '0'.
 - *WAITCOUNT3* is required and is explained later in this section.

Note: The SWE and SRE signals are only used on the 160 MAPBGA package.

13.2.1 SMARTMEDIA TIMING

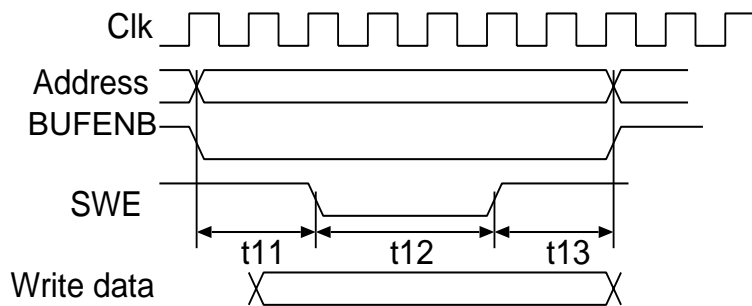

Figure 13-6 SmartMedia Timing

Table 13-6 SmartMedia Timing Values

SMARTMEDIA TIMING SYMBOL	TYPICAL VALUE NS	CONTROLLED BY SETTING	EQUATION (APPROXIMATELY)	COMMENT
tCLS, tCLH, tALS, tALH	20, 40	-	$CS2PRE > t1 - tbuf$	Realized in software because CLE and ALE are driven by gpio.
tREA	45	WAITCOUNT3	$(waitCount3 + 3.5)T > tREA$	
tDH	20	CS3POST	$CS3POST > tDH$	To meet this timing, typical value for cs3post is 20 ns

Setting Up The IDE Interface

Under typical circumstances, CS3PRE = 0 clocks, waitCount3 = 1 or 2.

Note: If CS3POST is set to 2, every write cycle is lengthened with 1 clock. If CS3POST is set to 3, every write cycle is lengthened with 2 clocks.

13.3 SETTING UP THE IDE INTERFACE

To set up the IDE interface, complete the following tasks.

1. Program the Chip Select 2 registers inside the chip select modules. (CSAR2, CSMR2, CSCR2).
 - CSAR2, CSMR2 must be programmed to see the IDE interface in the correct part of the ColdFire address map.
 - CSCR2 bit fields must be programmed as follows:
 - AA: 0 (TA signal generated by IDECONFIG2 register logic)
 - WS[3:0]: not relevant
 - PS[1:0]: 10 (16 bit port size)
 - BSTR, BSTW: 00 (no burst read/write cycles)
2. Program the IDE config1 register. Fields *CS2PRE*, *CS2POST*, *BUFEN1CS2EN*, *BUFEN2CS2EN*, and *SRE active during write* are relevant. The values required for the buffer enable signals *BUFEN1CS2EN* and *BUFEN2CS2EN* depend on the hardware configuration. If two buffers are used in cascade, both bits must be 1. Fields *CS2PRE* and *CS2POST* are relevant and are explained later in this section.
3. Program IDECONFIG2 register. Program this register as follows:
 - *TA enable 2* = '1'
 - *IORDY enable 2* = '1' if IORDY is connected from the IDE drive to the MCF5249 chip.
 - *IORDY enable 2* = '0' if IORDY wait handshake is not used.
 - *WAITCOUNT2* is required and is explained later in this section.

13.3.1 IDE TIMING DIAGRAM

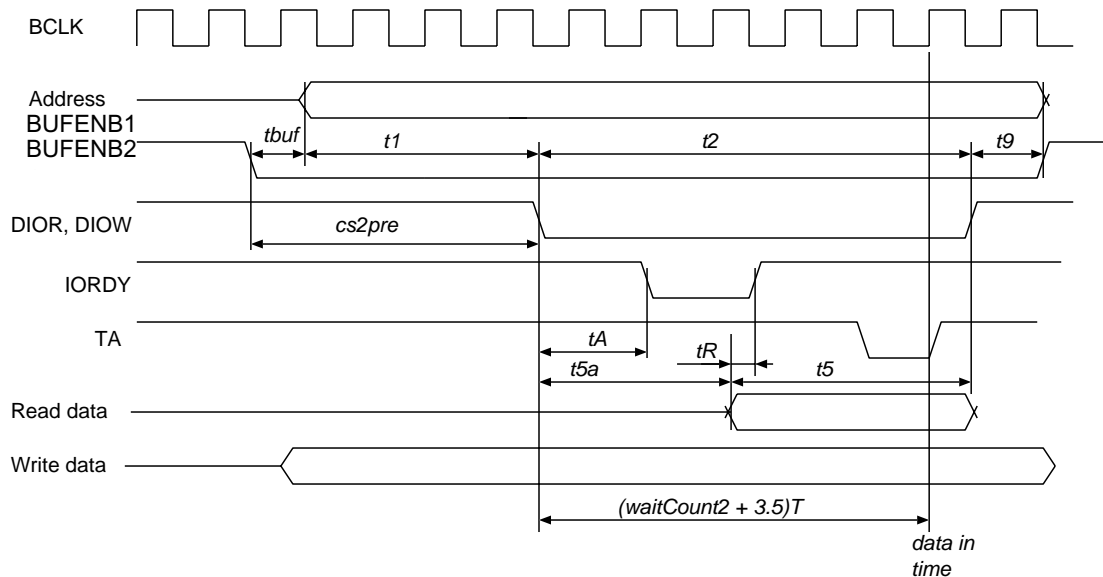

Figure 13-7 IDE Timing

Table 13-7 IDE Timing Values

ATA TIMING SYMBOL	ATA4 VALUE	CONTROLLED BY SETTING	EQUATION (APPROXIMATELY)	COMMENT
t1	25	CS2PRE	$CS2PRE > t1 - tbuf$	tbuf is external buffer enable time. cs2pre must be set high enough to provide sufficient address-to-DIOR, DIOW setup time. Typical cs2pre values will range from 3 to 5 SCLK clocks.
t2	70	WAITCOUNT2	$(WAITCOUNT2 + 4)T > t2$	t2 is the DIOR, DIOW low period. To meet 70 nS t2 period, waitCount2 must be set to 3.
t5a	50	WAITCOUNT2	$(WAITCOUNT2 + 3.5)T > t5a + t_{io} + tbuf$	tio: Input/output delay of device. Typ. 10 nS tbuf: External buffer delay. Typ. 15 nS To meet this timing, waitCount2 must be set to 4-5
tA	35	WAITCOUNT2	$(WAITCOUNT2 + 1.5)T > tA + t_{io}$	To meet this timing, waitCount2 must be set 3-4.
tR	0	-	$3T > tbuf + tdel - tR$	tdel: time difference between path from IORDY and from read data Read data in device must be valid 3 clocks after IORDY going high.
t9	10	CS2POST	$CS2POST > t9$	To meet this timing, typical value for cs2post is 10 nS.

Under typical circumstances, CS2PRE = 4 clocks, t2 = 7 clocks, dead time between 2 accesses = 4 clocks. In this case, the cycle time is 150 nS, yielding a 12 Mbyte/sec. sustained rate.

Note: If CS2POST is set to 2, every write cycle is lengthened with 1 clock. If CS2POST is set to 3, every write cycle is lengthened with 2 clocks. This marginally reduces throughput.

Note: A 3-clock cycle hold time to any MCF5249 external access has been added. As a result, hold time address to TA and write data to TA is not an issue.

13.4 FLASHMEDIA INTERFACE

The MCF5249 is capable of interfacing with Sony MemoryStick and Secure Digital flash cards. The interface can handle one of them at any given time, but not both at the same time.

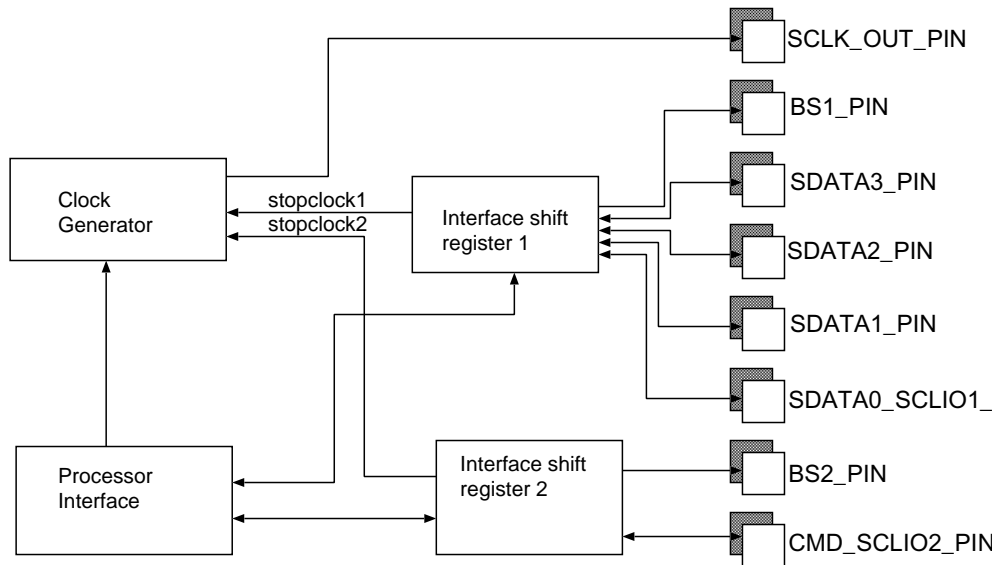

Figure 13-8 FlashMedia Block Diagram

In the FlashMedia interface there are four blocks:

1. The *clock generator* generates the clock to the flash device
2. The *Processor interface* handles interrupts and processor I/O.
3. Interface shift register 1
4. Interface shift register 2

Each interface shift register is a serial interface to the FlashMedia device. The two interfaces share the clock generating circuitry.

The flash media interface can operate in two modes.

1. *MemoryStick* mode. In this mode it is possible to connect two Sony MemoryStick cards. Each interface can handle one MemoryStick card. The two interfaces share only the clock generating logic, all other logic is fully independent.
2. *SecureDigital* mode. In this mode it is possible to connect one SD card. The SD card has a *command* line and 1 or 4 *serial data* lines. The interface shift register 1 will handle communication on the *serial data* lines, the interface shift register 2 will handle communication on the *command* line. From a software point of view, the two interfaces operate independently.

13.4.1 FLASHMEDIA INTERFACE REGISTERS

The FlashMedia interface contains eight 32-bit registers

Table 13-8 FlashMedia Registers

ADDRESS MBAR2BAS +	ACCESS	SIZE BITS	NAME	DESCRIPTION
0x460	RW	32	FLASHMEDIACONFIG	clock and general configuration
0x464	RW	32	FLASHMEDIACMD1	Command register for interface 1
0x468	RW	32	FLASHMEDIACMD2	Command register for interface 2
0x46C	RW	32	FLASHMEDIADATA1	Data register for interface 1
0x470	RW	32	FLASHMEDIADATA2	Data register for interface 2
0x474	RW	32	FLASHMEDIASTATUS	Status register
0x478	RW	32	FLASHMEDIADINTEN	Interrupt enable register
0x47C	R	32	FLASHMEDIADINTSTAT	Interrupt status register
0x47C	W	32	FLASHMEDIADINTCLEAR	Interrupt clear register

13.4.1.1 FlashMedia Clock Generation and Configuration

Clock generation and selection of the card type is accomplished by programming the FLASHMEDIACONFIG register as shown in the following table.

Table 13-9 FLASHMEDIACONFIG Register Configuration

FLASHMEDIACONFIG BITS	FIELD NAME	MEANING	RES	NOTES
7:0	CLOCKCOUNT0	(CLOCKCOUNT0+1) is the sclk_out_pin low period in number of bus clocks	15	1,2
15:8	CLOCKCOUNT1	(CLOCKCOUNT1+1) is the sclk_out_pin high period in number of bus clocks	15	1,2
17,16	STOPCLOCK	00: normal operation 01: freeze clock low 10: freeze clock high	01	2
18	-	reserved	0	
19	RECEIVEEDGE	1: receive data on falling edge of SCLK_OUT pin 0: receive data on rising edge of SCLK_OUT pin	0	3
21:20	CARDTYPE	00: Sony MemoryStick 01: SecureDigital, 1-bit serial data 11: SecureDigital, 4-bit serial data	0	

Note: 1. The clock generator will increase the length of some SCLK_OUT clock cycles to avoid bus contention when the SDIO pin switches from input to output, or from output to input mode. The clock generator will stop the SCLK_OUT clock if this is necessary to avoid buffer overrun or buffer underrun.

Note: 2. It is legal to reprogram these bits while the interface is running. No glitch will occur on sclk_out.

Note: 3. In SD mode, this bit should be programmed 1. In MemoryStick mode, programming 1 gives more relaxed timing, however MemoryStick specs stipulate it should be 0.

13.4.2 FLASHMEDIA INTERFACE OPERATION

The FlashMedia interface is build around two *Interface Shift Registers*, each of which work independently. The following figure shows a block diagram of one interface shift register.

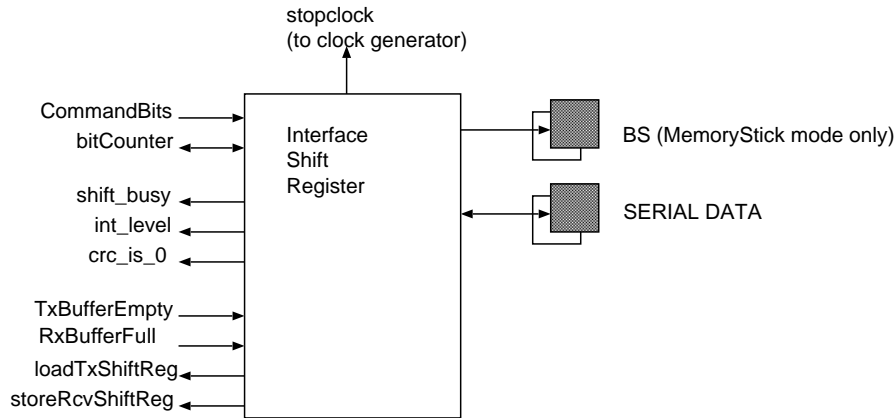

Figure 13-9 One Interface Shift Register

The processor interface sends *commands* to the interface shift register. One command instructs the interface shift register to do one of the following:

- Transmit a packet of N bits to the FlashMedia device. The number of bits N is programmable. It is also programmable if bits 15:0, or bits 47:0 in SD wide bus mode, need to be replaced with a valid CRC or not. CRC insertion is possible for MemoryStick data packet and SecureDigital data packets. CRC insertion is not possible for SecureDigital command packets.
- Receive a packet of N bits from the FlashMedia device. The number of bits N is programmable. After reception of all bits, the interface shift register will display on status line CRC_IS_0 if CRC check was successful or not. CRC check is done for MemoryStick data packets and for SecureDigital data packets. No CRC check is available for SD command packets.
- Wait for an interrupt event from the FlashMedia device

After writing a command to the interface shift register, the processor needs to monitor TxBUFFEREMPTY or RxBUFFERFULL, and read or write data to the interface as required.

- When the transmit shift register is empty, new data is loaded from the TxBUFFERREG. If the transmit buffer register is empty, the interface shift register will stop the SCLK_OUT clock, and wait for new data to be written in the TxBUFFERREG.
- When the receive shift register is full, data is transferred to the RxBUFFERREG. If the receive buffer register is full, the interface shift register will stop the SCLK_OUT clock, and wait until the RxBUFFERREG is read to empty.
- If the number of bits in the packet to sent/receive from the FlashMedia is greater than 32, multiple longword transfers to the buffer register are needed. All of these, except the first, contain 32 packet bits. The last data word for the transfer always contains packet bits 31-0, even if CRC transmit or check is on.

If e.g. a 48-bit transfer is requested to the FlashMedia, the first data word will contain 16 bits, the second one will contain 32 bits. The first word is LSB aligned for receive data, MSB aligned for transmit data.

This is also true if CRC insertion is involved. If a 4096 bit packet + 16 bit CRC need to be transmitted to the FlashMedia, 129 long-word transfers are needed. The first long-word will contain packet bits 4095:4080, MSB aligned. The last longword will contain packet bits 15:0 padded with 16 zeros or ones. The padded value will be replaced with the CRC by the transmit interface. (if the interface is programmed to do so.)

During and after transmission of a command, the processor can monitor the Interface Shift Register status by looking at some status signals.

- **SHIFT_BUSY** This signal is high while the data transmission is in progress.
- **INT_LEVEL** During interrupt commands, a high on this signal indicates an interrupt event coming from the FlashMedia.
- **CRC_IS_0** After a read transmission is completed, this signal indicates if the packet CRC was 0 or not.
- **BITCOUNTER.** This counter indicates the number of bits still to be exchange with the FlashMedia card.

13.4.2.1 FlashMedia Command Registers in MemoryStick Mode

Table 13-10 FLASHMEDIA COMMAND REGISTERS (MemoryStick Mode)

FLASHMEDIACMD1 FLASHMEDIACMD2 BITS	FIELD NAME	RW	MEANING	RES	NOTES
15:0	BITCOUNTER	RW	Write to this field the number of bits to be exchanged with the flash card. Read value is the number of bits remaining.	0	
19:16	CMDCODE		0001: read data (MemoryStick) 0010: write data (MemoryStick) 1000: wait for INT (MemoryStick)	0	
20	NEXT BS		next value to output on BS pin (MemoryStick)	0	
21	SEDCRC		0: No CRC inserted 1: packet bits 0-15 will be replaced with CRC	0	

13.4.2.2 FlashMedia Command Register 1 in Secure Digital Mode

Table 13-11 FLASHMEDIA COMMAND REGISTER 1 (Secure Digital Mode)

FLASHMEDIACMD1 BITS	FIELD NAME	RW	MEANING	RES	NOTES
15:0	BITCOUNTER	RW	Write to this field the number of bits to be exchanged with the flash card. Read value is the number of bits remaining.	0	
19:16	CMDCODE			0	
20	NEXT BS		next value to output on BS pin (MemoryStick)	0	

Table 13-11 FLASHMEDIA COMMAND REGISTER 1 (Secure Digital Mode) (Continued)

FLASHMEDIACMD1 BITS	FIELD NAME	RW	MEANING	RES	NOTES
21	SENDCRC		0: No CRC inserted 1: packet bits 0-15 will be replaced with CRC	0	
22	WIDESHIFT		0: 1-bit data bus 1: 4-bit data bus	0	
<p>Note: The following codes are relevant for FlashMedia command register 1:</p> <ul style="list-style-type: none"> FLASHMEDIACMD1[22:16] = 0x44: wait for read, 4 bit wide FLASHMEDIACMD1[22:16] = 0x04: wait for read, 1 bit wide FLASHMEDIACMD1[22:16] = 0x66: write data, 4 bit wide FLASHMEDIACMD1[22:16] = 0x26: write data, 1 bit wide FLASHMEDIACMD1[22:16] = 0x00: receive handshake FLASHMEDIACMD1[22:16] = 0x08: wait for busy signalling 					

13.4.2.3 FLASHMEDIA COMMAND REGISTER 2 in Secure Digital Mode

Table 13-12 FLASHMEDIA COMMAND REGISTER 2 (Secure Digital Mode)

FLASHMEDIACMD2 BITS	FIELD NAME	RW	MEANING	RES	NOTES
15:0	BITCOUNT ER	RW	Write to this field the number of bits to be exchanged with the flash card. Read value is the number of bits remaining.	0	
19:16	CMDCODE			0	
20	NEXT BS		next value to output on BS pin (MemoryStick)	0	
21	SENDCRC		reserved, should be 0	0	
22	DRIVECMD		0: do not drive command line 1: start driving command line after receiving card status response	0	
23	DRIVEDAT A		0: do not drive data line 1: start driving data line after command transmission end.		
<p>Note: The following codes are relevant for FlashMedia command register 2:</p> <ul style="list-style-type: none"> FLASHMEDIACMD2[23:16] = 0x46: Send read data command to SD. (drive cmd line after receiving flash status, do not drive data lines) FLASHMEDIACMD2[23:16] = 0x40: Receive status for read data command from SD FLASHMEDIACMD2[23:16] = 0xC6: Send write data command to SD. (Drive cmd line after receiving flash status. Drive data line after sending command.) FLASHMEDIACMD2[23:16] = 0xC0: Receive status for write data command from SD FLASHMEDIACMD2[23:16] = 0x06: Send non-data command to SD FLASHMEDIACMD2[23:16] = 0x00: Receive status for non-data command, stop driving cmd and data lines. 					

The commands and their meanings are described in detail later in this section.

13.4.3 FLASHMEDIA DATA REGISTER

Table 13-13 FLASHMEDIA DATA REGISTERS

FLASHMEDIADATA1 FLASHMEDIADATA2 BITS	FIELD NAME	RW	MEANING	RES	NOTES
31:0	TXBUFFERREG	W	Data written to this register will be transmitted	0	
31:0	RCVBUFFERREG	R	Read receive data from this register	0	

13.4.3.1 FlashMedia Status Register

Table 13-14 FLASHMEDIA STATUS REGISTER

FLASHMEDIASTAT BITS	FIELD NAME	RW	MEANING	RES	NOTES
0	CRC_IS_0_1	R	Interface 1 CRC status. Valid after read phase end. '1' indicates CRC OK, '0' indicates CRC fail	0	
1	SHIFT_BUSY1	R	Interface 1 shift status. '1' indicates interface busy shifting data, '0' indicates interface idle	0	
2	INT_LEVEL1	R	Interface 1 interrupt indicator. '1' indicates interrupt condition, requiring attention, '0' indicates no interrupt	0	
3	CRC_IS_0_2	R	Interface 2 CRC status. Valid after read phase end. '1' indicates CRC OK, '0' indicates CRC fail	0	
4	SHIFT_BUSY2	R	Interface 2 shift status. '1' indicates interface busy shifting data, '0' indicates interface idle		
5	INT_LEVEL2	R	Interface 2 interrupt indicator. '1' indicates interrupt condition, requiring attention, '0' indicates no interrupt		

13.4.4 FLASHMEDIA INTERRUPT INTERFACE

There are 12 interrupt sources associated with the FlashMedia interface. REGISTER FLASHMEDIASINTSTAT allows the viewing of pending interrupts. Register FLASHMEDIASINTEN allows the enabling of interrupts ('1' = enabled, '0' = disabled). Some interrupts can be cleared by writing a '1' to the corresponding bit of the FLASHMEDIASINTCLEAR register.

Table 13-15 FLASHMEDIA INTERRUPTS

FLASHMEDIINTSTAT FLASHMEDIINTEN FLASHMEDIINTCLEAR BITS	INT NAME	MEANING	RESET INTERRUPT	ASSOCIATED INTERRUPT
0	SHIFTBUSY1FALL	interrupt set on falling edge of shift_busy_1	intClear	60
1	SHIFTBUSY1RISE	interrupt set on rising edge of shift_busy_1	intClear	60
2	INTLEVEL1FALL	interrupt set on falling edge of int_level_1	intClear	60
3	INTLEVEL1RISE	interrupt set on rising edge of int_level_1	intClear	60
4	SHIFTBUSY2FALL	interrupt set on falling edge of shift_busy_2	intClear	59
5	SHIFTBUSY2RISE	interrupt set on rising edge of shift_busy_2	intClear	59
6	INTLEVEL2FALL	interrupt set on falling edge of int_level_2	intClear	59
7	INTLEVEL2RISE	interrupt set on rising edge of int_level_2	intClear	59
8	RCV1FULL	interrupt set if receive buffer reg 1 full	read data	58
9	TX1EMPTY	interrupt set if transmit buffer reg 1 empty	write data	58
10	RCV2FULL	interrupt set if receive buffer reg 2 full	read data	57
11	TX2EMPTY	interrupt set if transmit buffer reg 2 empty	write data	57

13.4.5 FLASHMEDIA INTERFACE OPERATION IN MEMORYSTICK MODE

Before any data exchange is possible with the MemoryStick, the FLASHMEDIACONFIG register must be written to set up the clock and the card type. After this, the card is accessed by issuing one of three possible command sequences. Each new command sent to the card, must toggle the BS line going out. The “handshake” phase of the MemoryStick can be implemented as a 16-bit read. There is no specific handshake command.

Note: The FlashMedia interface can handle two MemoryStick cards. One is attached to the primary interface, the other to the secondary interface. There is one potential issue. If there is a buffer full or a buffer empty on one interface, the system will freeze the outgoing SCLK signal, which causes the second interface to go into a wait-state as well.

13.4.5.1 Reading Data From the MemoryStick

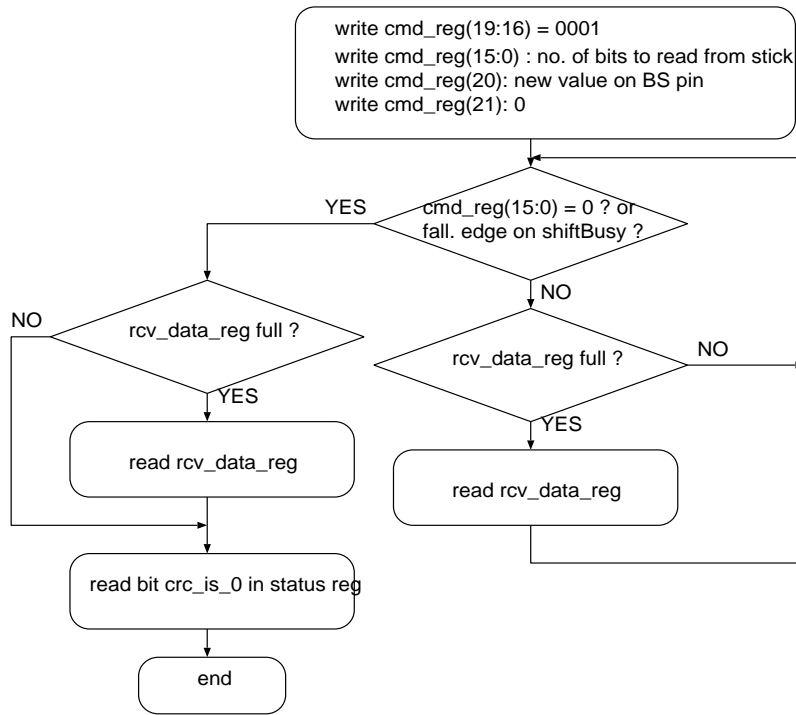
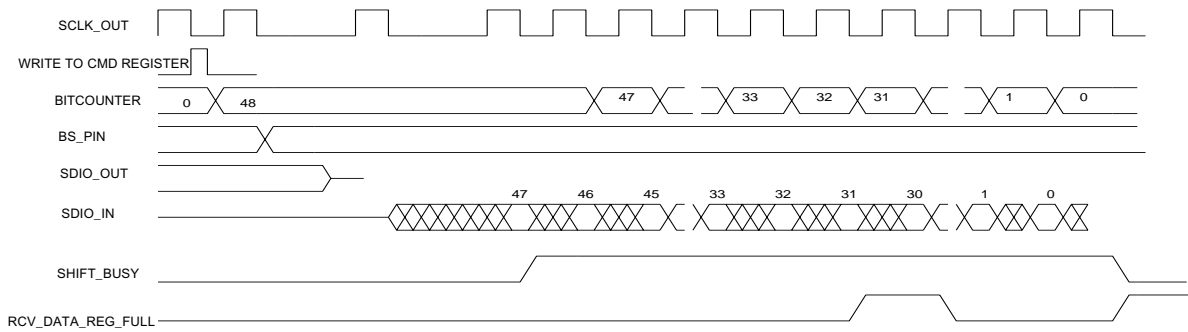

Figure 13-10 Reading Data From MemoryStick



Memory Stick interface timing diagram for cmd_reg(19:16) = 0001 (Read data from stick)

Figure 13-11 Reading Data From MemoryStick Timing

In the timing diagram, the assumption is made that the processor reads the full receive buffer register before the next 32 bits are received. If this is not the case, the FlashMedia interface will stop the outgoing sclk clock which prevents data overrun.

13.4.5.2 Writing Data to the MemoryStick

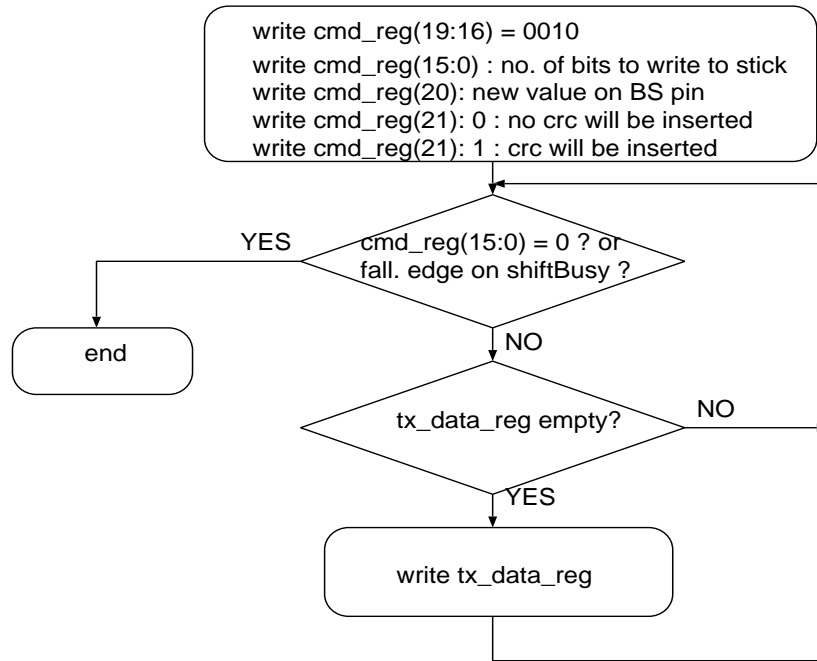

Figure 13-12 Writing Data To MemoryStick

A timing diagram is also given. In this timing diagram, the assumption is made the processor writes the empty transmit buffer register before the next 32 bits are transmitted. If this is not the case, the FlashMedia interface will stop the outgoing sclk clock, and in this way prevent data underrun.

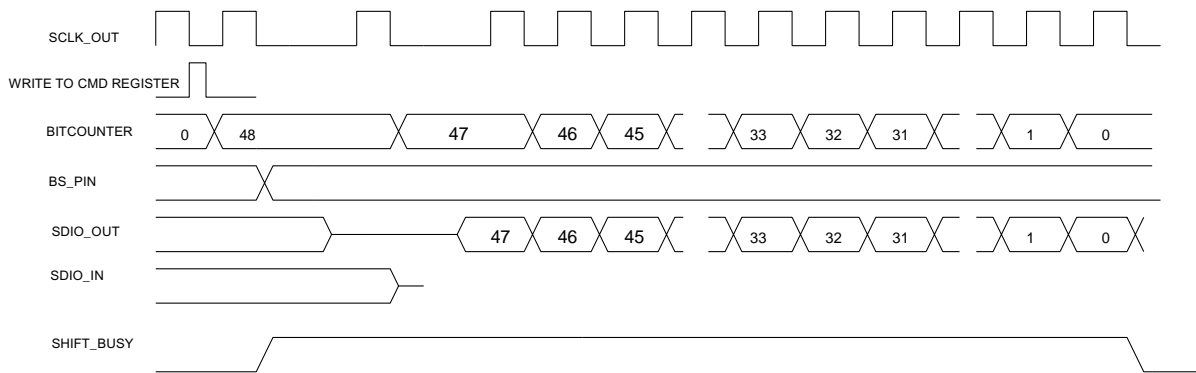
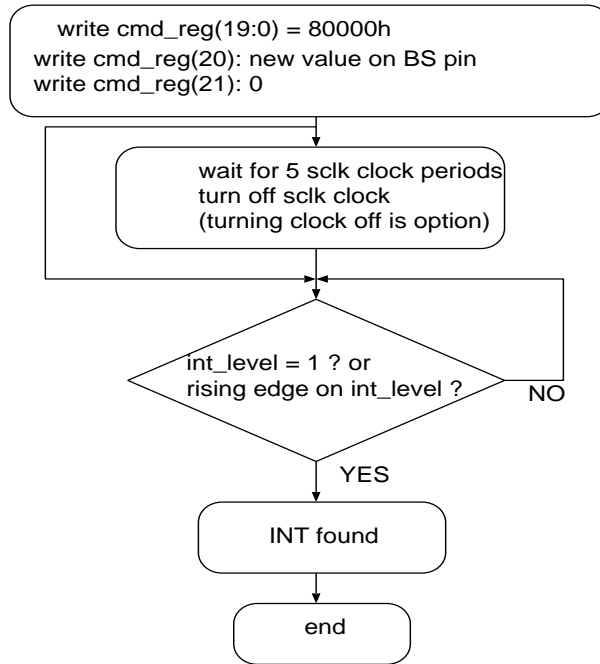

Figure 13-13 Writing Data to MemoryStick Timing

13.4.5.3 Interrupt From MemoryStick



Program flow diagram for INT transfer to MemoryStick

Figure 13-14 Interrupt From MemoryStick

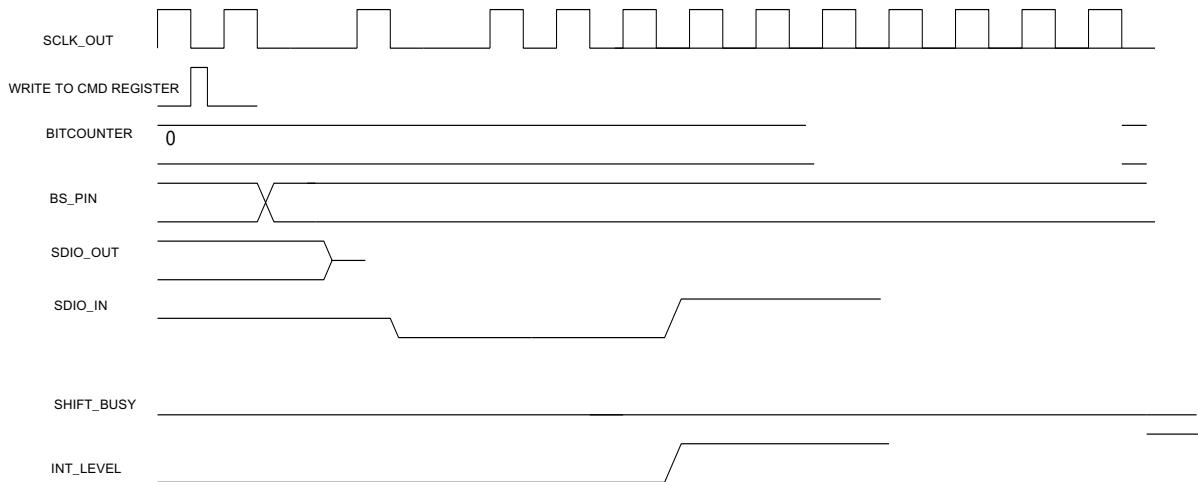

Memory Stick interface timing diagram for cmd_reg(19:16) = 1000
(Wait for INT from stick)

Figure 13-15 Interrupt From MemoryStick

13.4.6 FLASHMEDIA INTERFACE OPERATION IN SECURE DIGITAL (SD) MODE

All interactions to the Secure Digital (SD) card can be broken down in a number of cascaded elementary operations. There are three elementary operations to the card in SD mode:

- Sent command to card
- Read data from card (one or more packets)
- Write data to card (one or more packets)

13.4.6.1 Sent Command To Card

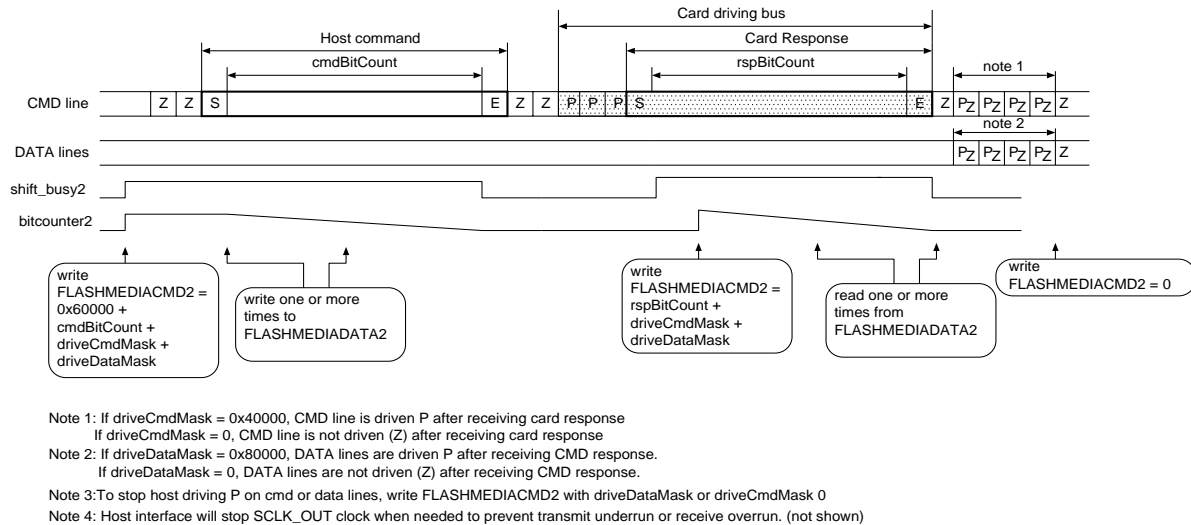

Figure 13-16 Sent Command To Card

The sent-command sequence first sends out a command on the CMD line, then receives a card response on the same CMD line. After receiving the card response, the host may drive the CMD and DATA lines depending on the values of the DRIVECMDMASK and DRIVEDATAMASK.

Note: Both lines must be driven if the next operation is sending a write data packet to the card. The CMD line must be driven, while DATA lines are kept Z when the next operation is receiving read data from the card. Both CMD and DATA lines are kept Z when no data follows the command.

While the host is sending data and receiving status from the card, it must look for events on the SHIFTBUSY2 status bit in the FLASHMEDIASTATUS register. It is also possible to capture these events using the SHIFTBUSY2RISE and SHIFTBUSY2FALL interrupts.

To exchange data with the card, the host must write the FLASHMEDIADATA2 register when TX2EMPTY interrupt is set, or read FLASHMEDIADATA2 when RCV2FULL is set. This can be done by using interrupts, by polling FLASHMEDIADINTSTAT, or by using a DMA channel on FLASHMEDIADATA2.

A number of bits/bytes/longwords corresponding with CMDBITCOUNT must be written to FLASHMEDIADATA2 during the command transmission. All words, except the first word, contain 32 bits of data. The first word contains the remainder. The data in the first word is left-justified. No CRC logic is present in hardware, so CRC must be inserted by software.

A number of bits/bytes/longwords corresponding with RESPBITCOUNT must be read from FLASHMEDIADATA2 during the response phase. All words, except the first word, contain 32 bits of data. The first word contains the remainder. The data in the first word is right-justified. No CRC logic is present in hardware, so CRC must be inserted by software.

The writing of RSPBITCOUNT + DRIVECMDMASK + DRIVEDATAMASK to FLASHMEDIACMD2 must take place after SHIFTBUSY2 has gone high.

13.4.6.2 Write Data To Card

Following two timing diagrams show write data to card sequence with and without busy response from the card.

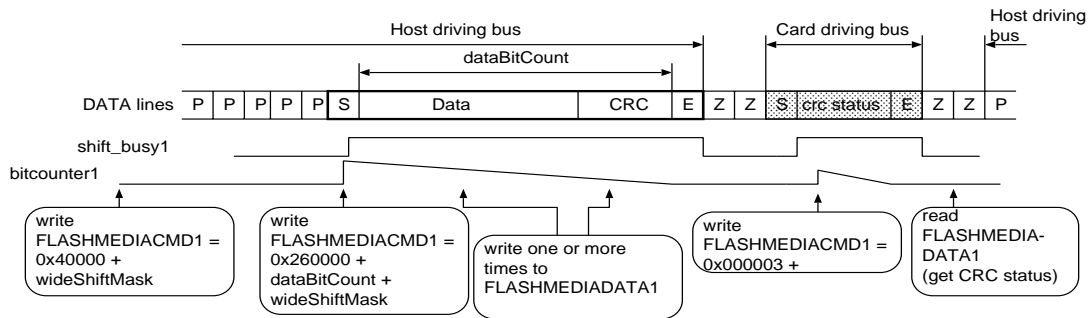

- Note 1: For 4-bit wide bus, wideShiftMask is 0x400000, CRC length is 64 bits
For 1-bit wide bus, wideShiftMask = 0, CRC length is 16 bits.
- Note 2: If read data packet followed by another read data packet (block read), set readDataMask = 0x40000. If only one read data packet, set readDataMask = 0.
- Note 3: Host interface will stop SCLK_OUT clock when needed to prevent transmit underrun or receive overrun. (not shown)

Figure 13-17 Write Data To Card With Busy

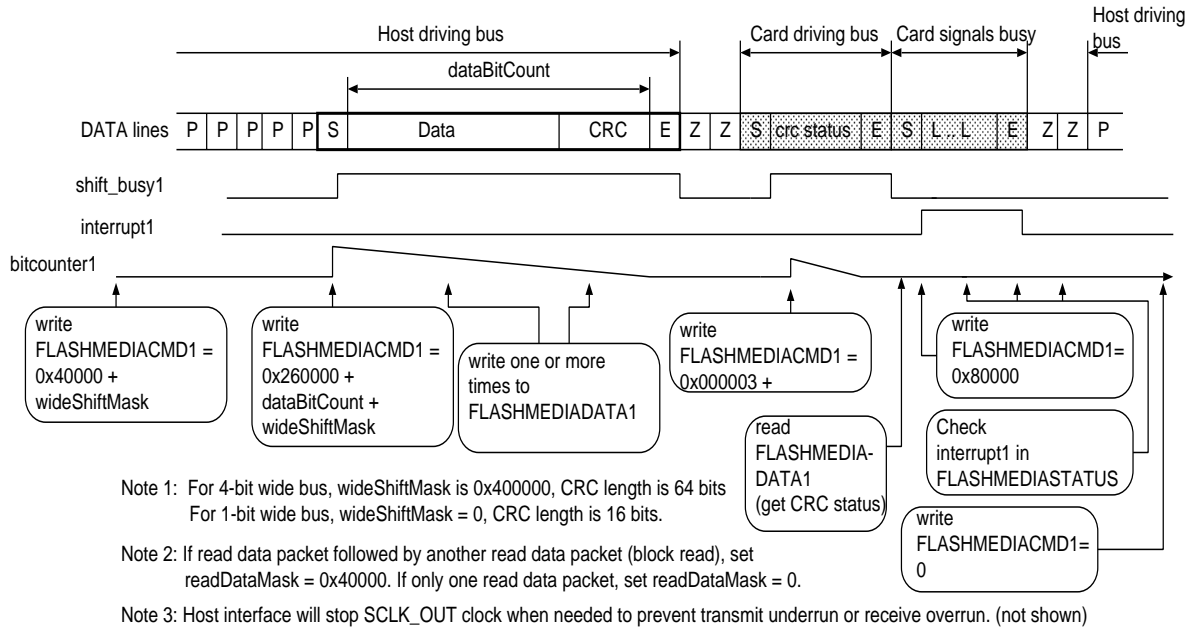

Figure 13-18 Write Data To Card Without Busy

The write data sequence sends out a write packet on the DATA line, receives a CRC STATUS response from the card, and then looks for a potential busy.

The *DATABITCOUNT* is the number of bits in the packet. This includes the CRC bits. There are 16 CRC bits for the 1-bit bus, 64 CRC bits for the 4-bit bus. The number of bits/bytes/longwords that need to be written to FLASHMEDIADATA1 corresponds with DATABITCOUNT. The user needs to write dummy data in stead of the CRC bits to FLASHMEDIADATA1. (use all-zero or whatever. The CRC value is calculated inside the FlashMediaInterface, and the CRC bits written to FLASHMEDIADATA1 are discarded. All words, except the first word, written to FLASHMEDIADATA1 contain 32 bits of data. The first word contains the remainder. Data in the first word must be left-justified.

To read the CRC status, the host must read FLASHMEDIADATA1 once. The CRC status are the three LSB's of the value read.

During this sequence, the host must look for events on SHIFT_BUSY1 and INTERRUPT1. This is accomplished by polling FLASHMEDIASTATUS or FLASHMEDIAINSTATUS, or by waiting for interrupts SHIFTBUSY1RISE, SHIFTBUSY1FALL, INTERRUPT1RISE, INTERRUPT1FALL.

To read/write data to/from FLASHMEDIADATA1, the host can poll FLASHMEDIAINSTAT, wait for interrupt, or use a DMA channel. In the following figures, the DATA lines default to a "P" state: strong '1' driven by host. This is only the case if DRIVEDATAMASK was set during last write to FLASHMEDIACMD2. Writing 0x000003 to FLASHMEDIACMD1 must take place after SHIFTBUSY1 has gone high. One or more write packets can be sent to the card using this timing diagram.

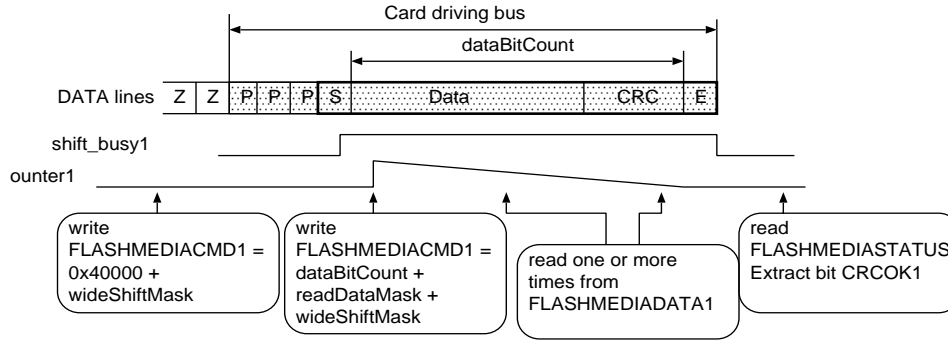

Note 1: For 4-bit wide bus, wideShiftMask is 0x400000, CRC length is 64 bits
 For 1-bit wide bus, wideShiftMask = 0, CRC length is 16 bits.

Note 2: If read data packet followed by another read data packet (block read), set readDataMask = 0x40000. If only one read data packet, set readDataMask = 0.

Note 3: Host interface will stop SCLK_OUT clock when needed to prevent transmit underrun or receive overrun. (not shown)

Figure 13-19 Read Data From Card

The read sequence reads a packet on the data line.

The DATABITCOUNT is the number of bits in the packet. This includes the CRC bits. There are 16 CRC bits for the 1-bit bus, 64 CRC bits for the 4-bit bus. The number of bits/bytes/longwords that need to be read from FLASHMEDIADATA1 corresponds with DATABITCOUNT. The CRC will be read from FLASHMEDIADATA1 too. The user need not check the CRC in software. This is done in hardware. The result can be retrieved in bit *crcstatus1* in register FLASHMEDIASTATUS after packet read end. All words, except the first word, read from FLASHMEDIADATA1 contain 32 bits of data. The first word contains the remainder. Data in the first word is right-justified.

During this sequence, the host must look for events on SHIFT_BUSY1 and INTERRUPT1. This can be done by polling FLASHMEDIASTATUS or FLASHMEDIAINSTATUS, or by waiting for interrupts SHIFTBUSY1RISE, SHIFTBUSY1FALL, INTERRUPT1RISE, INTERRUPT1FALL. To read/write data to/from FLASHMEDIADATA1, the host can poll FLASHMEDIAINSTAT, wait for interrupt, or use a DMA channel. The writing of DATABITCOUNT + READDATAMASK + WIDESHIFTMASK to FLASHMEDIACMD1 must take place after SHIFTBUSY1 has gone high. One or more read packets can be received from the card using this timing diagram

13.4.7 COMMONLY USED COMMANDS IN SD MODE

Some pseudo-code descriptions are given in this section for sent command, read multiple block, and write multiple block commands.

13.4.7.1 Send Command To Card (No Data)

This sequence is intended for commands that require status response from the card, but no data transfer between host and card. There are no provision to do CRC insertion or check for command and response packets. All need to be done in software.

```
/* write command to host */
CMDBITCOUNT = 46
FLASHMEDIACMD2 = 0x060000 + CMDBITCOUNT
while(CMDBITCOUNT > 0)
```

```

{
if(FLASHMEDIADATA2 empty)
{
write data to FLASHMEDIADATA2
CMDBITCOUNT:= CMDBITCOUNT - 32;
}
}
/* one of the two waits need to be done. */
/* First one is more suitable for polling */
/* second one more suitable for interrupt driven */
wait until ((FLASHMEDIACMD2 & 0xFFFF) == 0) OR
wait until (SHIFTBUSY2FALL event)

/* receive status from host */
wait until (SHIFTBUSY2RISE event) OR
wait until ((FLASHMEDIASTATUS & 8)!= 0)
RESPBITCOUNT = 46 or 134 /* depends on command */
FLASHMEDIACMD2 = RESPBITCOUNT;
while(RESPBITCOUNT > 0)
{
if(FLASHMEDIADATA2 full)
{
read data from FLASHMEDIADATA2
RESPBITCOUNT:= RESPBITCOUNT - 32;
}
}
}

```

13.4.7.2 Send Command To Card (Receive Multiple Data Blocks and Status)

This sequence sends a read data command to the card. The card sends back a response token on the CMD line, while at the same time sending the data on the DATA lines. The sequence is set to receive BLOCKCOUNT data packets from the card. No STOP command is sent as part of this sequence.

```

CMDBITCOUNT = 46
if(wide_shift_mode)
wide_shift_mask = 0x400000;
else
wide_shift_mask = 0;
FLASHMEDIACMD2 = 0x460000 + CMDBITCOUNT
FLASHMEDIACMD1 = 0x040000 + wide_shift_mask
while(CMDBITCOUNT > 0)
{
if(FLASHMEDIADATA2 empty)
{
read FLASHMEDIADATA2
CMDBITCOUNT = CMDBITCOUNT - 32;
}
}
wait until ((FLASHMEDIACMD2 & 0xFFFF) == 0) OR
wait until (SHIFTBUSY2FALL event)
/* start receiving data and status */
RESPBITCOUNT = 46 or 134;
BLOCKCOUNT = <N>;

```



```

while(BLOCKCOUNT > 0)
{
-- start reception of new block
DATABITCOUNT = <blocklen> + crclen;
while(DATABITCOUNT > 0 || RESPBITCOUNT > 0)
{
if(RESPBITCOUNT > 0 && SHIFTBUSY2RISE event)
FLASHMEDIACMD2 = 0x400000 + RESPBITCOUNT;
if(SHIFTBUSY1RISE event)
if(BLOCKCOUNT == 1) /* last block */
FLASHMEDIACMD1 =
0x000000 + dataBitCount + wide_shift_mask;
else
FLASHMEDIACMD1 =
0x040000 + dataBitCount + wide_shift_mask;
if(FLASHMEDIADATA2 full)
{
read FLASHMEDIADATA2
RESPBITCOUNT = RESPBITCOUNT - 32;
}
if(FLASHMEDIADATA1 full)
{
read FLASHMEDIADATA1
dataBitCount = dataBitCount - 32;
}
}
}
if((FLASHMEDIASTATUS & 1) == 1)
CRC OK!.
BLOCKCOUNT = BLOCKCOUNT - 1;
}

```

13.4.7.3 Send Command To Card (Write Multiple Data Blocks)

This sequence sends a write data command to the card. The card sends back a response token on the CMD line. After receiving this response, the host starts transmitting data on the DAT lines. After every data packet, the card sends back a CRC status response, followed by a possible busy.

The sequence is set to sent BLOCKCOUNT data packets to the card. No STOP command is sent as part of this sequence.

```

/* write command to host */
CMDBITCOUNT = 46
if(wide_shift_mode)
wide_shift_mask = 0x400000;
else
wide_shift_mask = 0;
FLASHMEDIACMD2 = 0xC60000 + CMDBITCOUNT
while(CMDBITCOUNT > 0)
{
if(FLASHMEDIADATA2 empty)
{
write data to FLASHMEDIADATA2
CMDBITCOUNT:= CMDBITCOUNT - 32;
}
}
}/* one of the two waits need to be done. */
/* First one is more suitable for polling */

```

FlashMedia Interface

```

/* second one more suitable for interrupt driven */
wait until ((FLASHMEDIACMD2 & 0xFFFF) == 0) OR
wait until (SHIFTBUSY2FALL event)

/* receive status from host */
wait until (SHIFTBUSY2RISE event) OR
wait until ((FLASHMEDIASTATUS & 8) != 0)
RESPBITCOUNT = 46 or 134 /* depends on command */
FLASHMEDIACMD2 = 0xC00000 + RESPBITCOUNT;
while(RESPBITCOUNT > 0)
{
if(FLASHMEDIADATA2 full)
{
read data from FLASHMEDIADATA2
RESPBITCOUNT:= RESPBITCOUNT - 32;
}
}
}

/* start sending data to card */
BLOCKCOUNT:= <N>
while(BLOCKCOUNT > 0)
{
-- start transmission of new block
DATABITCOUNT = <blockLen> + crcLen;
FLASHMEDIACMD1 = 0x260000 + dataBitCount +
wide_shift_mask;
while(DATABITCOUNT > 0)
{
if(FLASHMEDIADATA1 empty)
{
write data to FLASHMEDIADATA1
DATABITCOUNT = DATABITCOUNT - 32;
}
}
}
wait until((FLASHMEDIACMD1 & 0xFFFF) == 0) OR
wait until (SHIFTBUSY1FALL event)
-- receive CRC status from card
wait until (SHIFTBUSY1RISE event) OR
wait until ((FLASHMEDIASTATUS & 2) != 0)
FLASHMEDIACMD1 = 3;
wait until(FLASHMEDIADATA1 full)
CRC status = 0x7 & FLASHMEDIADATA1

FLASHMEDIACMD1 = 0x80000;
/* wait for interrupt now.
On rising edge of busy, INTLEVEL1RISE event will
occur. On falling edge of busy, INTLEVEL1FALL event
will occur. During busy, (FLASHMEDIASTATUS & 4) == 4
*/
wait until ((FLASHMEDIASTATUS & 4) == 0) /* busy end */
FLASHMEDIACMD1 = 0;
BLOCKCOUNT:= BLOCKCOUNT - 1;
}
FLASHMEDIACMD2 = 0;

```

Section 14

DMA Controller Module

The direct memory access (DMA) controller module quickly and efficiently moves blocks of data with minimal processor overhead. The DMA module, shown in Figure 14-1, provides four channels that allow byte, word, or longword operand transfers. These transfers should be dual address to on-chip devices; such as the UART, SDRAM controller, and audio module.

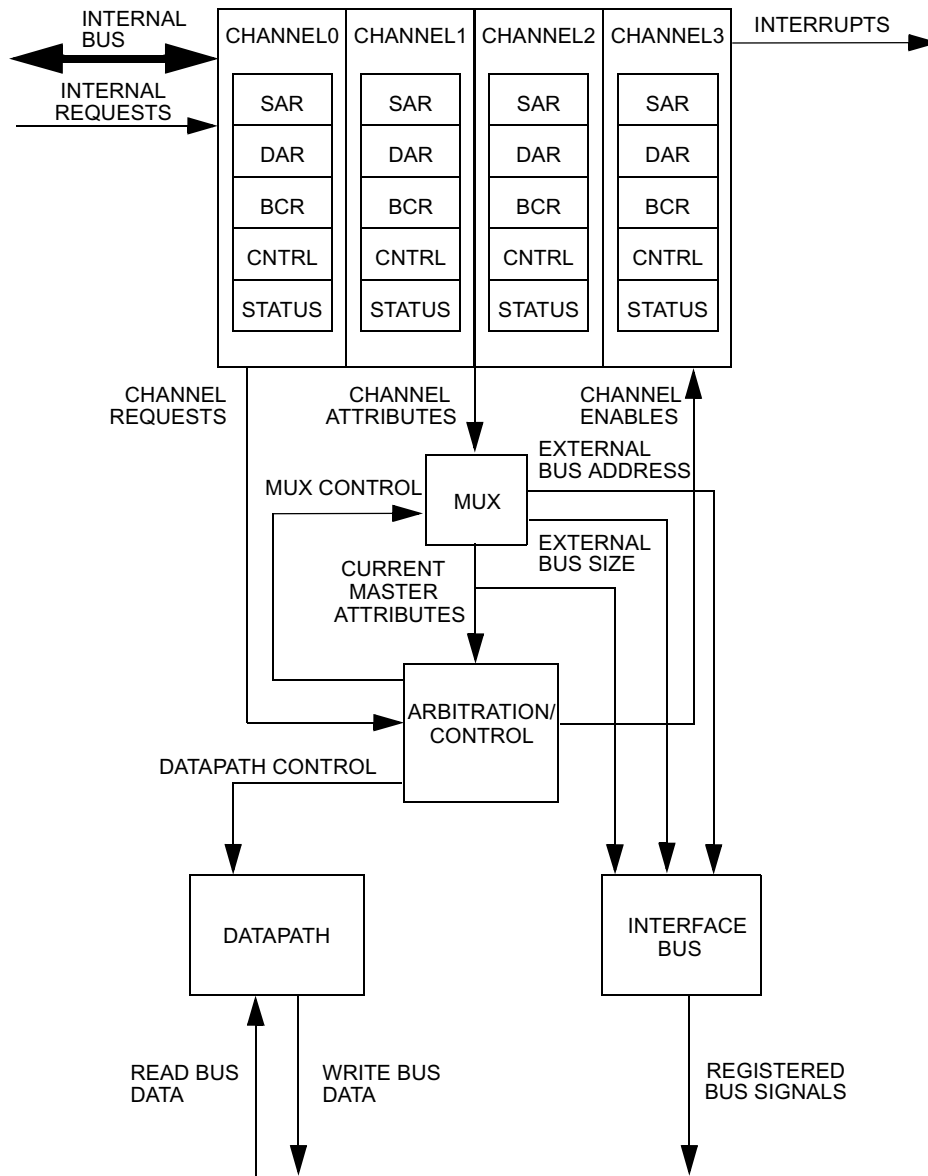

Figure 14-1 DMA Signal Diagram

14.1 DMA FEATURES

- Four fully independent programmable DMA controller module channels/bus modules
- Auto-alignment feature for source or destination accesses
- Dual-address transfer capability
- Programmable hardware request lines from the audio module and UART going to all 4 DMA channels
- Channels 2 and 3 request signals may be connected to the interrupt lines of UART0 and UART1, respectively
- Channel arbitration on transfer boundaries
- Data transfers in 8-, 16-, 32-, or 128-bit blocks using a 16-byte buffer
- Burst and cycle steal transfers
- Independent transfer widths for source and destination
- Independent source and destination address registers
- Data transfer in two clocks

14.2 DMA SIGNAL DESCRIPTION

This section contains a brief description of the DMA module signals that provide handshake control for either a source or destination external device. [Table 14-1](#) summarizes these handshake signals

Table 14-1 DMA Signals

SIGNAL NAME	DIRECTION	DESCRIPTION
REQUEST[3:0]	In	DMA Request signal coming from internal modules

14.2.1 DMA REQUEST

These internal signals, REQUEST[3:0], are DMA request inputs. There is one input for each of the 4 DMA channels. The request sources are selectable by programming the DMAROUTE register. Each DMA channel is programmable individually.

The internal signals are asserted by a peripheral device to request an operand transfer between that peripheral and memory.

14.3 DMA MODULE OVERVIEW

The DMA controller module usually transfers data at rates much faster than the ColdFire core under software control can handle. The term DMA refers to the ability for a peripheral device to access memory in a system in the same manner as a microprocessor. DMA operations can greatly increase overall system performance.

The DMA module consists of four independent channels. The term DMA is used throughout this section to reference any of the four channels, as they are all functionally equivalent. It is impossible to implicitly address all four DMA channels at the same time. The MCF5249 on-chip peripherals do not support the single-address transfer mode.

DMA requests can be generated by the processor writing to the START bit in the DMA control register or generated by an on-chip peripheral device asserting one of the REQUEST signals. The processor can program the amount of bus bandwidth allocated for the DMA for each channel. The DMA channels support continuous and cycle-steal transfer modes.

Note: REQUEST[3:0] are internal signals only.

The DMA controller supports dual-address transfers. In dual-address mode, the DMA channel supports 32 bits of address and 32 bits of data. Dual-address transfers can be initiated by either an processor request using the START bit or by an internal peripheral device using the REQUEST signal. Two bus transfers occur in this mode, a read from a source device and a write to a destination device (see [Figure 14-2](#)).

Any operation involving the DMA module follows the same three basic steps:

1. Channel initialization step — The DMA channel registers are loaded with control information, address pointers, and a byte transfer count. Also, the DMAROUTE register is programmed to control the source of REQUEST[3:0]
2. Data transfer step — The DMA accepts requests for operand transfers and provides addressing and bus control for the transfers.
3. Channel termination step — This occurs after operation is complete. The channel indicates the status of the operation in the channel status register.

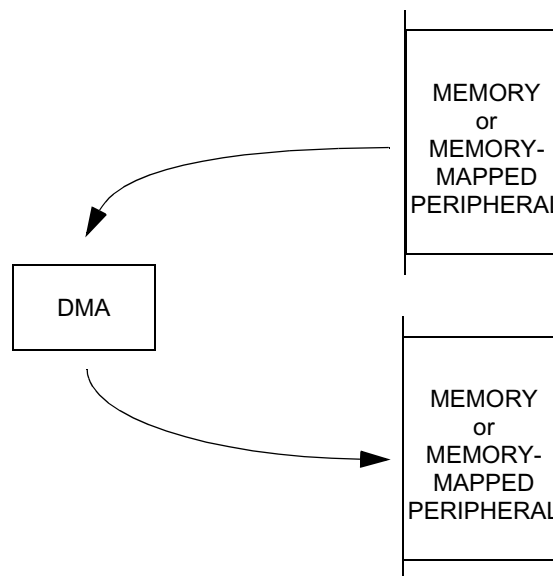

Figure 14-2 Dual Address Transfer

14.4 DMA PROGRAMMING MODEL

The registers of each channel are mapped into memory as shown in [Table 14-2](#).

The DMA control module registers determine the operation of the DMA controller module. This section describes each of the internal registers and its bit assignment.

Note: There is no mechanism for preventing a write to a control register during DMA transfer.

Table 14-2 Memory Map DMA Channel 0

DMA CHANNEL	ADDRESS	[31:24]	[23:16]	[15:8]	[7:0]
	MBAR+\$188	DMAROUTE - Request source control			
Channel 0	MBAR+\$300	Source Address Register 0			
	MBAR+\$304	Destination Address Register 0			
	MBAR+\$308	DMA Control Register 0			
	MBAR+\$30C	Byte Count Register 0		Reserved	
	MBAR+\$310	Status Register 0	Reserved		
	MBAR+\$314	Interrupt Vector Register 0	Reserved		

Table 14-3 Memory Map DMA Channel 1

DMA CHANNEL	ADDRESS	[31:24]	[23:16]	[15:8]	[7:0]
Channel 1	MBAR+\$340	Source Address Register 1			
	MBAR+\$344	Destination Address Register 1			
	MBAR+\$348	DMA Control Register 1			
	MBAR+\$34C	Byte Count Register 1		Reserved	
	MBAR+\$350	Status Register 1	Reserved		
	MBAR+\$354	Interrupt Vector Register 1	Reserved		

Table 14-4 Memory Map DMA Channel 2

DMA CHANNEL	ADDRESS	[31:24]	[23:16]	[15:8]	[7:0]
Channel 2	MBAR+\$380	Source Address Register 2			
	MBAR+\$384	Destination Address Register 2			
	MBAR+\$388	DMA Control Register 2			
	MBAR+\$38C	Byte Count Register 2		Reserved	
	MBAR+\$390	Status Register 2	Reserved		
	MBAR+\$394	Interrupt Vector Register 2	Reserved		

Table 14-5 Memory Map DMA Channel 3

DMA CHANNEL	ADDRESS	[31:24]	[23:16]	[15:8]	[7:0]
Channel 3	MBAR+\$3C0	Source Address Register 3			
	MBAR+\$3C4	Destination Address Register 3			
	MBAR+\$3C8	DMA Control Register 3			
	MBAR+\$3CC	Byte Count Register 3		Reserved	
	MBAR+\$3D0	Status Register 3	Reserved		
	MBAR+\$3D4	Interrupt Vector Register 3	Reserved		

Note: Table 14-2 is for BCR24BIT = 0. Table 14-6 shows the difference in the memory map when BCR24BIT = 1.

Table 14-6 Memory Map (DMA Controller Registers —BCR24BIT = 1)

DMA CHANNEL	ADDRESS OFFSET FROM MBAR	[31:24]	[23:0]
Channel 0	30C	Reserved	Byte Count Register 0
Channel 1	34C	Reserved	Byte Count Register 1
Channel 2	38C	Reserved	Byte Count Register 2
Channel 3	3CC	Reserved	Byte Count Register 3

14.4.1 REQUEST SOURCE SELECTION

The routing control register (DMAroute) controls where the non-processor DMA request for the four DMA channels is coming from.

Table 14-7 DMAroute Register

BITS	31	30	29	28	27	26	25	24	23	22	21	20	19	18	17	16
FIELD	DMA3REQ								DMA2REQ							
RESET	0	0	0	0	0	0	0	0	0	0	0	0	0	0	0	0
R/W	R/W	R/W	R/W	R/W	R/W	R/W	R/W	R/W	R/W	R/W	R/W	R/W	R/W	R/W	R/W	R/W
BITS	15	14	13	12	11	10	9	8	7	6	5	4	3	2	1	0
FIELD	DMA1REQ								DMA0REQ							
RESET	0	0	0	0	0	0	0	0	0	0	0	0	0	0	0	0
R/W	R/W	R/W	R/W	R/W	R/W	R/W	R/W	R/W	R/W	R/W	R/W	R/W	R/W	R/W	R/W	R/W
MBAR2 + \$188)																

Table 14-8 DMAroute Register Fields

DMAROUTE BITS	FIELD NAME	DMA CHANNEL
31:24	DMA3REQ(7:0)	DMA3
23:16	DMA2REQ(7:0)	DMA2
15:8	DMA1REQ(7:0)	DMA1
7:0	DMA0REQ(7:0)	DMA0

Table 14-9 describes DMA route fields.

Table 14-9 DMA3REQ Field Definition

DMA3REQ(7:0) FIELD VALUE	REQUEST SOURCE FOR DMA	BLOCK
0x80	DMA3: UART 1	UART1
0x00	reserved	
0x01	reserved	
0x02	reserved	
0x03	reserved	
0x04	reserved	
0x05	reserved	
0x06	reserved	
0x07	reserved	
0x08	reserved	
0x09	reserved	
0x0A	reserved	
0x0B	reserved	
0x0C	reserved	
0x0D	reserved	
0x0E	reserved	
0x0F	reserved	

Table 14-10 DMA2REQ Field Definition

DMA2REQ(7:0) FIELD VALUE	REQUEST SOURCE FOR DMA	BLOCK
0x80	DMA2: UART 0	UART0
0x00	reserved	
0x01	reserved	
0x02	reserved	
0x03	reserved	
0x04	reserved	
0x05	reserved	
0x06	reserved	
0x07	reserved	
0x08	reserved	

Table 14-10 DMA2REQ Field Definition (Continued)

DMA2REQ(7:0) FIELD VALUE	REQUEST SOURCE FOR DMA	BLOCK
0x09	reserved	
0x0A	reserved	
0x0B	reserved	
0x0C	reserved	
0x0D	reserved	
0x0E	reserved	
0x0F	reserved	

Table 14-11 DMA1REQ Field Definition

DMA1REQ(7:0) FIELD VALUE	REQUEST SOURCE FOR DMA	BLOCK
0x80	DMA1: audio source 1	audio
0x81	DMA1: audio source 2	audio
0x00	reserved	
0x01	reserved	
0x02	reserved	
0x03	reserved	
0x04	reserved	
0x05	reserved	
0x06	reserved	
0x07	reserved	
0x08	reserved	
0x09	reserved	
0x0A	reserved	
0x0B	reserved	
0x0C	reserved	
0x0D	reserved	
0x0E	reserved	
0x0F	reserved	

Table 14-12 DMA0REQ Field Definition

DMA0REQ(7:0) FIELD VALUE	REQUEST SOURCE FOR DMA	BLOCK
0x80	DMA0: audio source 1	audio
0x81	DMA0: audio source 2	audio
0x00	reserved	
0x01	reserved	
0x02	reserved	
0x03	reserved	
0x04	reserved	
0x05	reserved	
0x06	reserved	
0x07	reserved	
0x08	reserved	
0x09	reserved	
0x0A	reserved	
0x0B	reserved	
0x0C	reserved	
0x0D	reserved	
0x0E	reserved	
0x0F	reserved	

14.4.2 SOURCE ADDRESS REGISTER

The source address register (SAR) is a 32-bit register containing the address from which the DMA controller module requests data during a transfer.

Table 14-13 Source Address Register (SAR)

BITS	31	30	29	28	27	26	25	24	23	22	21	20	19	18	17	16
FIELD	SAR3 1	SAR3 0	SAR2 9	SAR2 8	SAR2 7	SAR2 6	SAR2 5	SAR2 4	SAR2 3	SAR2 2	SAR2 1	SAR2 0	SAR1 9	SAR1 8	SAR1 7	SAR1 6
RESET	0	0	0	0	0	0	0	0	0	0	0	0	0	0	0	0
R/W	R/W	R/W	R/W	R/W	R/W	R/W	R/W	R/W	R/W	R/W	R/W	R/W	R/W	R/W	R/W	R/W
BITS	15	14	13	12	11	10	9	8	7	6	5	4	3	2	1	0
FIELD	SAR1 5	SAR1 4	SAR1 3	SAR1 2	SAR1 1	SAR1 0	SAR9	SAR8	SAR7	SAR6	SAR5	SAR4	SAR3	SAR2	SAR1	SAR0

Table 14-13 Source Address Register (SAR) (Continued)

RESET	0	0	0	0	0	0	0	0	0	0	0	0	0	0	0	0
R/W	R/W	R/W	R/W	R/W	R/W	R/W	R/W	R/W	R/W	R/W	R/W	R/W	R/W	R/W	R/W	R/W
MBAR + \$300), MBAR+ \$340, MBAR + \$380, MBAR + \$3C0)																

Note: Only part of the on-chip SRAM can be accessed by the DMA. The memory controlled by RAMBAR0 is not visible for DMA. The memory controlled by RAMBAR1 is visible for DMA. As a result, the SAR or DAR address range cannot be programmed to on-chip SRAM0 memory, since the on-chip DMAs cannot access on-chip SRAM0 as a source or destination. They can access SRAM1, however.

14.4.3 FLASHMEDIA DATA REGISTERS

The destination address register (DAR) is a 32-bit register containing the address to which the DMA controller module sends data during a transfer.

Table 14-14 Destination Address Register (DAR)

BITS	31	30	29	28	27	26	25	24	23	22	21	20	19	18	17	16
FIELD	DAR3 1	DAR3 0	DAR2 9	DAR2 8	DAR2 7	DAR2 6	DAR2 5	DAR2 4	DAR2 3	DAR2 2	DAR2 1	DAR2 0	DAR1 9	DAR1 8	DAR1 7	DAR1 6
RESET	0	0	0	0	0	0	0	0	0	0	0	0	0	0	0	0
R/W	R/W	R/W	R/W	R/W	R/W	R/W	R/W	R/W	R/W	R/W	R/W	R/W	R/W	R/W	R/W	R/W
MBAR + \$304, MBAR + \$344, MBAR + \$384, MBAR + \$3C4																
BITS	15	14	13	12	11	10	9	8	7	6	5	4	3	2	1	0
FIELD	DAR1 5	DAR1 4	DAR1 3	DAR1 2	DAR1 1	DAR1 0	DAR9	DAR8	DAR7	DAR6	DAR5	DAR4	DAR3	DAR2	DAR1	DAR0
RESET	0	0	0	0	0	0	0	0	0	0	0	0	0	0	0	0
R/W	R/W	R/W	R/W	R/W	R/W	R/W	R/W	R/W	R/W	R/W	R/W	R/W	R/W	R/W	R/W	R/W

Note: The MCF5249 on-chip DMAs must be careful when transferring data to cacheable memory since the on-chip DMAs do not maintain cache coherency with the MCF5249 instruction cache.

14.4.4 BYTE COUNT REGISTER

The byte count register (BCR) is a 24-bit register containing the number of bytes remaining to be transferred for a given block. The offset within the memory map is based on the value of the BCR24BIT bit in the MPARK register of the SIM module. See the following table for the bit locations.

Note: If the BCR24BIT = 1, the upper 8 bits are loaded with zeros.

The BCR decrements on the successful completion of the address phase of a write transfer in dual-address mode. The amount the BCR decrements is 1, 2, 4, or 16 for byte, word, longword, or line accesses, respectively.

Table 14-15 Byte Count Register (BCR)—BCR24BIT = 1

BITS	31	30	29	28	27	26	25	24	23	22	21	20	19	18	17	16
FIELD	RESERVED								BCR2 3	BCR2 2	BCR2 1	BCR2 0	BCR1 9	BCR1 8	BCR1 7	BCR1 6
RESET									0	0	0	0	0	0	0	0
R/W									R/W	R/W	R/W	R/W	R/W	R/W	R/W	R/W
BITS	15	14	13	12	11	10	9	8	7	6	5	4	3	2	1	0
FIELD	BCR1 5	BCR1 4	BCR1 3	BCR1 2	BCR1 1	BCR1 0	BCR9	BCR8	BCR7	BCR6	BCR5	BCR4	BCR3	BCR2	BCR1	BCR0
RESET	0	0	0	0	0	0	0	0	0	0	0	0	0	0	0	0
R/W	R/W	R/W	R/W	R/W	R/W	R/W	R/W	R/W	R/W	R/W	R/W	R/W	R/W	R/W	R/W	R/W
MBAR + \$30C, MBAR + \$34C, MBAR + \$38C, MBAR + \$3CC																

Table 14-16 Byte Count Register (BCR)—BCR24BIT = 0

BITS	31	30	29	28	27	26	25	24	23	22	21	20	19	18	17	16
FIELD	BCR1 5	BCR1 4	BCR1 3	BCR1 2	BCR1 1	BCR1 0	BCR9	BCR8	BCR7	BCR6	BCR5	BCR4	BCR3	BCR2	BCR1	BCR0
RESET																
R/W	R/W	R/W	R/W	R/W	R/W	R/W	R/W	R/W	R/W	R/W	R/W	R/W	R/W	R/W	R/W	R/W
BITS	15	14	13	12	11	10	9	8	7	6	5	4	3	2	1	0
FIELD	RESERVED															
RESET																
R/W																
MBAR + \$30C, MBAR + \$34C, MBAR + \$38C, MBAR + \$3CC																

The DONE bit DMA status register (Figure 14-2) is set when the entire block transfer is complete.

When a transfer sequence is initiated and the BCR contains a value that is not divisible by 16, 4, or 2 when the DMA is configured for line, longword, or word transfers, respectively, the configuration error bit (CE) in the DMA status register (DSR) is set and the transfer does not take place. Refer to [Section 14.4.6 DMA Status Register](#) for more details.

14.4.5 DMA CONTROL REGISTER

The DMA control register (DCR) sets the configuration of the DMA controller module. Depending on the state of the BCR24BIT in the MPARK register in the SIM module, the DMA control register looks slightly different. Specifically, the AT bit (DCR[15]) is included when BCR24BIT = 1, providing greater flexibility in DMA transfer acknowledge.

Table 14-17 DMA Control Register (DCR)—BCR24BIT = 0

BITS	31	30	29	28	27	26	25	24	23	22	21	20	19	18	17	16
FIELD	INT	EEXT	CS	AA	BWC			DAA	S_RW	SINC	SSIZE		DINC	DSIZE	START	
RESET																

Table 14-17 DMA Control Register (DCR)—BCR24BIT = 0 (Continued)

R/W	R/W															
BITS	15	14	13	12	11	10	9	8	7	6	5	4	3	2	1	0
FIELD	RESERVED															
RESET																
R/W																
MBAR + \$308, MBAR + \$348, MBAR + \$388, MBAR + \$3C8																

Table 14-18 DMA Control Bit Descriptions

BIT NAME	DESCRIPTION
INT	<p>The Interrupt on completion of transfer field determines whether an interrupt is generated at the completion of the transfer or occurrence of an error condition.</p> <p>0 = No interrupt is generated. 1 = Internal interrupt signal is enabled.</p>
EEXT	<p>Enable peripheral request. Collision could occur between the START bit and the REQUEST signal when EEXT = 1. Therefore, caution should be exercised when initiating a DMA transfer with the START bit while EEXT = 1.</p> <p>0 = Peripheral request is ignored. 1 = Enables peripheral request to initiate transfer. Internal request is always enabled. It is initiated by writing a 1 to the START bit</p>
CS	<p>Cycle steal.</p> <p>0 = DMA continuous make read/write transfers until the BCR decrements to zero. 1 = Forces a single read/write transfer per request. The request may be processor by setting the START bit, or periphery by asserting the REQUEST signal. (Can be generated by the processor.)</p>
AA	<p>The auto-align bit and the SIZE bits determine whether the source or destination is auto-aligned. Auto alignment means that the accesses are optimized based on the address value and the programmed size. For more information, see Section 14.7.2 Data Transfer.</p> <p>0 = Auto-align disabled. 1 = If the SSIZE bits indicate a larger or equivalent transfer size with respect to DSIZE, then the source accesses are auto-aligned. If the DSIZE bits indicate a larger transfer size than SSIZE, then the destination accesses are auto-aligned. Source alignment takes precedence over destination alignment. If auto- alignment is enabled, the appropriate address register increments, regardless of the state of DINC or SINC.</p>

Table 14-18 DMA Control Bit Descriptions (Continued)

BIT NAME	DESCRIPTION																							
BWC	<p>The three bandwidth control bits are decoded for internal bandwidth control. When the byte count reaches any multiple of the programmed BWC boundary, the request signal to the internal arbiter is negated until data access completes. This enables the arbiter to give another device access to the bus. Table 14-19 shows the encoding for these bits. When the bits are cleared, the DMA does not negate its request. The 000 encoding asserts a priority signal when the channel is active, signaling that the transfer has been programmed for a higher priority. When the BCR reaches a multiple of the values shown in the table, the bus is relinquished.</p> <p>For example, if BWC = 001 (512 bytes or value of 0x0200), BCR24BIT = 0, and the BCR is set to 0x1000, the bus is relinquished after BCR values of 0x2000, 0x1E00, 0x1C00, 0x1A00, 0x1800, 0x1600, 0x1400, 0x1200, 0x1000, 0x0E00, 0x0C00, 0x0A00, 0x0800, 0x0600, 0x0400, and 0x0200. In another example, BWC = 110, BCR24BIT = 0, and the BCR is set to 33000. The bus is relinquished after transferring 232 bytes, because the BCR is at 32768, which is a multiple of 16384.</p> <div style="text-align: center;"> <p>Table 14-19 BWC Encoding</p> <table border="1"> <thead> <tr> <th data-bbox="678 789 781 905" rowspan="2">BWC</th> <th colspan="2" data-bbox="781 789 1151 846">BLOCK SIZE</th> </tr> <tr> <th data-bbox="781 846 972 905">BCR24BIT = 0</th> <th data-bbox="972 846 1151 905">BCR24BIT = 1</th> </tr> </thead> <tbody> <tr> <td data-bbox="678 905 781 947">000</td> <td colspan="2" data-bbox="781 905 1151 947">DMA has priority</td> </tr> <tr> <td data-bbox="678 947 781 989">001</td> <td data-bbox="781 947 972 989">512</td> <td data-bbox="972 947 1151 989">16384</td> </tr> <tr> <td data-bbox="678 989 781 1031">010</td> <td data-bbox="781 989 972 1031">1024</td> <td data-bbox="972 989 1151 1031">32768</td> </tr> <tr> <td data-bbox="678 1031 781 1073">011</td> <td data-bbox="781 1031 972 1073">2048</td> <td data-bbox="972 1031 1151 1073">65536</td> </tr> <tr> <td data-bbox="678 1073 781 1115">100</td> <td data-bbox="781 1073 972 1115">4096</td> <td data-bbox="972 1073 1151 1115">131072</td> </tr> <tr> <td data-bbox="678 1115 781 1157">101</td> <td data-bbox="781 1115 972 1157">8192</td> <td data-bbox="972 1115 1151 1157">262144</td> </tr> </tbody> </table> </div>	BWC	BLOCK SIZE		BCR24BIT = 0	BCR24BIT = 1	000	DMA has priority		001	512	16384	010	1024	32768	011	2048	65536	100	4096	131072	101	8192	262144
BWC	BLOCK SIZE																							
	BCR24BIT = 0	BCR24BIT = 1																						
000	DMA has priority																							
001	512	16384																						
010	1024	32768																						
011	2048	65536																						
100	4096	131072																						
101	8192	262144																						
S_RW	Reserved, must be set to 0.																							
DAA	<p>Dual address access.</p> <p>0 = The DMA channel is in dual-address mode. 1 = Reserved</p>																							
SINC	<p>The source increment bit determines whether the source address increments after each successful transfer.</p> <p>0 = No change to the SAR after a successful transfer. 1 = The SAR increments by 1, 2, 4, or 16; depending upon the size of the transfer.</p>																							

Table 14-18 DMA Control Bit Descriptions (Continued)

BIT NAME	DESCRIPTION										
SSIZE	<p>The source size field determines the data size of the source bus cycle for the DMA control module. Table 14-20 shows the encoding for this field.</p> <p style="text-align: center;">Table 14-20 SSIZE Encoding</p> <table border="1" style="margin-left: auto; margin-right: auto;"> <thead> <tr> <th>SSIZE</th> <th>TRANSFER SIZE</th> </tr> </thead> <tbody> <tr> <td>00</td> <td>Longword</td> </tr> <tr> <td>01</td> <td>Byte</td> </tr> <tr> <td>10</td> <td>Word</td> </tr> <tr> <td>11</td> <td>Line</td> </tr> </tbody> </table>	SSIZE	TRANSFER SIZE	00	Longword	01	Byte	10	Word	11	Line
SSIZE	TRANSFER SIZE										
00	Longword										
01	Byte										
10	Word										
11	Line										
DINC	<p>The destination increment bit determines whether the destination address increments after each successful transfer.</p> <p>0 = No change to the DAR after a successful transfer. 1 = The DAR increments by 1, 2, 4, or 16; depending upon the size of the transfer.</p>										
DSIZE	<p>The Destination Size field determines the data size of the destination bus cycle for the DMA controller module. Table 14-21 shows the encoding for this field.</p> <p style="text-align: center;">Table 14-21 DSIZE Encoding</p> <table border="1" style="margin-left: auto; margin-right: auto;"> <thead> <tr> <th>SSIZE</th> <th>TRANSFER SIZE</th> </tr> </thead> <tbody> <tr> <td>00</td> <td>Longword</td> </tr> <tr> <td>01</td> <td>Byte</td> </tr> <tr> <td>10</td> <td>Word</td> </tr> <tr> <td>11</td> <td>Line</td> </tr> </tbody> </table>	SSIZE	TRANSFER SIZE	00	Longword	01	Byte	10	Word	11	Line
SSIZE	TRANSFER SIZE										
00	Longword										
01	Byte										
10	Word										
11	Line										
START	<p>Start transfer.</p> <p>0 = DMA inactive. 1 = The DMA begins the transfer in accordance to the values in the control registers. This bit is self-clearing after one clock and is always read as logic 0.</p>										

14.4.6 DMA STATUS REGISTER

The 8-bit DMA status register (DSR) indicates the status of the DMA controller module. The DMA controller module, in response to an event, writes to the appropriate bit in the DSR. Only a write to the DONE bit (DSR[0]) results in action. Setting the DONE bit creates a single-cycle pulse which resets the channel, thus clearing all bits in the register. The DONE bit is set at the completion of a transfer or during the transfer to abort the access.

[Table 14-22](#) shows the detailed structure of the DMA status register.

Table 14-22 DMA Status Register (DSR)

BITS	7	6	5	4	3	2	1	0
FIELD	–	CE	BES	BED	–	REQ	BSY	DONE
RESET		0	0	0		1	1	1
R/W		R/W	R/W	R/W		R/W	R/W	R/W
MBAR + \$310, MBAR + \$350, MBAR + \$390, MBAR + \$3D0								

Table 14-23 DMA Status Bit Descriptions

BIT NAME	DESCRIPTION
Bit 7	Reserved
CE	<p>A configuration error results when either the number of bytes represented by the BCR is not consistent with the requested source or destination transfer size. Configuration error can also result from the SAR or DAR containing an address that does not match the requested transfer size for the source or destination. The bit is cleared during a hardware reset or by writing a one to DSR[DONE].</p> <p>0 = No configuration error exists. 1 = A configuration error has occurred.</p>
BES	<p>Bus error on source.</p> <p>0 = No bus error occurred. 1 = The DMA channel terminated with a bus error either during the read portion of a transfer.</p>
BED	<p>Bus error on destination.</p> <p>0 = No bus error occurred. 1 = The DMA channel terminated with a bus error during the write portion of a transfer.</p>
Bit 3	Reserved
REQ	<p>Request</p> <p>0 = There is no request pending or the channel is currently active. The bit is cleared when the channel is selected. 1 = The DMA channel has a transfer remaining and the channel is not selected.</p>
BSY	<p>Busy</p> <p>0 = DMA channel is inactive. This bit is cleared when the DMA has finished the last transaction. 1 = This bit is set the first time the channel is enabled after a transfer is initiated.</p>

Table 14-23 DMA Status Bit Descriptions (Continued)

BIT NAME	DESCRIPTION
DONE	<p>The transaction done bit may be read or written and is set when all DMA controller module transactions have completed normally, as determined by the transfer count and error conditions. When the BCR reaches zero, DONE is set at the successful conclusion of the final transfer.</p> <p>Writing a 1 to this bit clears all DMA status bits and therefore can be used as an interrupt handler to clear the DMA interrupt and error bits. The DONE bit can also be used to abort a transfer in progress by resetting the status bits. The DONE bit is self clearing. Therefore, writing a 0 to it has no effect.</p> <p>0= Writing or reading a 0 has no effect whatsoever. 1= DMA transfer completed.</p>

14.4.7 DMA INTERRUPT VECTOR REGISTER

The DMA Interrupt Vector Register (DIVR) is an 8-bit register, which is driven out onto the bus in response to an internal acknowledge cycle.

Table 14-24 DMA Interrupt Vector Register (DIVR)

BITS	7	6	5	4	3	2	1	0
FIELD	INTERRUPT VECTOR BITS							
RESET	0	0	0	0	1	1	1	1
R/W	R/W	R/W	R/W	R/W	R/W	R/W	R/W	R/W
MBAR + \$314, MBAR + \$354, MBAR + \$394, MBAR + \$3D4								

14.5 TRANSFER REQUEST GENERATION

The DMA channel supports processor and periphery requests. Bus utilization can be minimized for either processor or periphery request by selecting between cycle-steal and continuous modes. The DCR[EEXT] field determines the request-generation method for each channel.

14.5.1 CYCLE-STEAL MODE

The DMA is in cycle-steal mode if the CS field (DCR[29]) is set. In this mode, only one complete transfer from source to destination takes place for each request. Depending on the state of the EEXT field (DCR[30]), the request can be either processor or periphery. Processor request is selected by setting the START bit (DCR[16]). Periphery request is initiated by asserting the REQUEST signal while the EEXT bit is set.

14.5.2 CONTINUOUS MODE

The DMA is in continuous mode if the CS field (DCR[29]) is cleared. After an internal or external request is asserted, the DMA continuously transfers data until the byte count register (BCR) reaches zero or the DONE bit (DSR[0]) is set.

The continuous mode can operate at maximum or limited rate. The maximum rate of transfer can be achieved if the bandwidth control BWC field (DCR[27:25]) is programmed to 000. Then the active DMA channel continues until the BCR decrements to zero or the DONE bit is set.

A limited rate can be achieved by programming the BWC field to any value other than 000. The DMA performs the specified number of transfers, then relinquishes control of the bus. The DMA negates its internal bus request on the last transfer before the BCR reaches a multiple of the boundary specified in the BWC field. On transfer completion, the DMA asserts its bus request again to regain bus ownership at the earliest opportunity, as determined by the internal bus arbiter. The minimum time that the DMA loses bus control is one bus cycle.

14.6 DATA TRANSFER MODES

Each DMA channel supports dual-address transfers. The dual-address transfer mode consists of a source operand read and a destination operand write.

14.6.1 DUAL-ADDRESS TRANSACTION

The DMA controller module begins a dual-address transfer sequence when the DAA bit (DCR[24]) is cleared during a DMA request. If no error condition exists, the REQ bit (DSR[2]) is set.

14.6.1.1 Dual-Address Read

The DMA controller module will drive the value in the source address register (SAR) onto the internal address bus. If the SINC bit (DCR[22]) is set, then the SAR increments by the appropriate number of bytes upon a successful read cycle. When the appropriate number of read cycles completes successfully, the DMA initiates the write portion of the transfer.

In the event of a termination error, the BES (DSR[5]) and DONE bit (DSR[0]) are set and no further DMA transactions take place.

14.6.1.2 Dual-Address Write

The DMA controller module drives the value in the destination address register (DAR) onto the address bus. If the DINC bit (DCR[19]) is set, then the DAR increments by the appropriate number of bytes at the completion of a successful write cycle. The byte count register (BCR) decrements by the appropriate number of bytes. The DONE bit (DSR[0]) is set when the BCR reaches zero. If the BCR is greater than zero, then another read/write transfer is initiated. If the byte count register (BCR) is a multiple of the programmed bandwidth control (BWC), then the DMA request signal is negated until termination of the bus cycle to allow the internal arbiter to switch masters.

In the event of a termination error, the BES (DSR[5]) and DONE bit (DSR[0]) are set and no further DMA transactions takes place.

14.7 DMA TRANSFER FUNCTIONAL DESCRIPTION

In the following section, the term DMA request implies that the START bit (DCR[16]) is set or the EEXT bit (DCR[30]) is set, followed by assertion of REQUEST. The START bit is cleared when the channel begins an internal access.

Before initiating a transfer, the DMA controller module verifies that the source size (SSIZE = DSC[21:20]) and destination size (DSIZE = DSR[18:17]) for dual-address access are consistent with the source address and destination address. The CE bit is also set if inconsistency is found between the destination size and the source size in the BCR for dual-address access. If a misalignment is detected, no transfer occurs and the configuration error bit (CE = DSR[6]) is set. Depending on the configuration of the DCR, an interrupt event may be issued when the CE bit is set.

Note: If the auto-align bit (AA = DCR[28]) is set, error checking is performed on the appropriate registers only.

A read/write transfer refers to a dual-address access in which a number of bytes are read from the source address and written to the destination address. The number of bytes in the transfer is determined by the larger of the sizes specified by the source and destination size encoding. See [Table 14-20](#) and [Table 14-21](#).

The source and destination address registers (SAR and DAR) increment at the completion of a successful address phase. The BCR decrements at the completion of a successful address write phase. A successful address phase occurs when a valid address request is not held by the arbiter.

14.7.1 CHANNEL INITIALIZATION AND STARTUP

Before starting a block transfer operation, the channel registers must be initialized with information describing the channel configuration, request-generation method, and data block. This initialization is accomplished by programming the appropriate information into the channel registers.

14.7.1.1 Channel Prioritization

The four DMA channels are prioritized in ascending order (channel 0 having highest priority and channel 3 having the lowest) or as determined by the BWC bits in the DCR. If the BWC bits for a DMA channel are set to 000, then that channel has priority over the channel immediately preceding it. For example, if DMA channel 3 has the BWC bits set to 000, it has priority over DMA channel 2 but not over DMA channel 1. This is assuming that DMA channel 2 has something other than all zeroes in the BWC bits.

Another example would be the case where the BWC bits in only DMA 2 and DMA 1 are all zeroes. In this case, DMA 1 would have priority over DMA 0 and DMA 2. The BWC bits being zero in DMA 2 in this case have no effect on prioritization.

In the case of simultaneous external requests, the prioritization is either ascending or as determined by each channels BWC bits as described in the previous paragraphs.

14.7.1.2 Programming the DMA

The following are some general comments on programming the DMA:

- No mechanism exists for preventing writes to control registers during DMA accesses
- If the BWC of sequential channels are equivalent, channel priority is in ascending order

The SAR is loaded with the source (read) address. If the transfer is from a peripheral device to memory, the source address is the location of the peripheral data register. If the transfer is from memory to a peripheral device or memory to memory, the source address is the starting address of the data block. This address can be any byte address.

The DAR should contain the destination (write) address. If the transfer is from a peripheral device to memory, or memory to memory, the DAR is loaded with the starting address of the data block to be written. If the transfer is from memory to a peripheral device, the DAR is loaded with the address of the peripheral data register. This address can be any byte address.

The manner in which the SAR and DAR change after each cycle depends on the values in the DCR SSIZE and DSIZE fields and the SINC and DINC bits, and the starting address in the SAR and DAR. If programmed to increment, the increment value is 1, 2, 4, or 16 for byte, word, longword, or line operands, respectively. If the address register is programmed to remain unchanged (no count), the register is not incremented after the operand transfer.

The BCR must be loaded with the number of byte transfers that are to occur. This register is decremented by 1, 2, 4, or 16 at the end of each transfer. The DSR must be cleared for channel startup.

Once the channel has been initialized, it is started by writing a one to the START bit in the DCR or asserting the REQUEST signal, depending on the status of the EEXT bit in the DCR. Programming the channel for processor request causes the channel to request the bus and start transferring data immediately. If the channel is programmed for periphery request, $\overline{\text{REQUEST}}$ must be asserted before the channel requests the bus.

If any fields in the DCR are modified while the channel is active, that change is effective immediately. To avoid any problems with changing the setup for the DMA channel, a 1 should be written to the DONE bit in the DSR to stop the DMA channel.

14.7.2 DATA TRANSFER

14.7.2.1 Periphery Request Operation

All channels can initiate transfers to/from a periphery module by means of REQUEST[3:0]. Source where REQUEST is coming from is programmed in register DMAROUTE. If the EEXT bit (DCR[30]) is set, when a REQUEST is asserted, the DMA initiates a transfer provided the channel is idle. If the CS (cycle steal) bit is set, the read/write transaction on the bus is limited to a single transfer. If the CS bit is clear, multiple read/write transfers can occur on the bus as programmed. REQUEST does not need to be negated until the DONE bit (DSR[0]) is set.

14.7.2.2 Auto Alignment

This feature allows for block transfers to occur at the optimum size based on the address, byte count, and programmed size. To use this feature, AA in the DCR must be set. The source is auto-aligned when the SSIZE bits indicate a larger transfer size compared to DSIZE. Source alignment takes precedence over the destination when the source and destination sizes are equal. Otherwise, the destination is auto-aligned. The address register that is chosen for alignment increments regardless of the value of the increment bit. Configuration error checking is performed on the registers that are not chosen for alignment.

If the BCR contains a value greater than 16, the address will determine the size of the transfer. Single byte, word or longword transfers will occur until the address is aligned to the programmed size boundary, at which time the programmed size accesses begin. When the BCR is less than 16 at the beginning of a read/write transfer, the number of bytes remaining will dictate the transfer size, longword, word or byte.

For example:

AA = 1, SAR = \$0001, BCR = \$00f0, SSIZE = 00 (longword) and DSIZE = 01 (byte),

Because the SSIZE > DSIZE, the source is auto-aligned. Error checking is performed on the destination registers. The sequence of accesses is as follows:

1. Read byte from \$0001—write byte, increment SAR
2. Read word from \$0002—write 2 bytes, increment SAR
3. Read long word from \$0004—write 4 bytes, increment SAR
4. Repeat longwords until SAR = \$00f0
5. Read byte from \$00f0—write byte, increment SAR.

If DSIZE is set to another size, then the data writes are optimized to write the largest size allowed based on the address, but not exceeding the configured size.

14.7.2.3 Bandwidth Control

This feature makes provision to force the DMA off the bus to allow another master access. Bus arbiter design was simplified by making arbitration programmable. The decode of the DCR[BWC] field provides 7 levels of block transfer sizes. If the BCR decrements to a value that is a multiple of the decode of the BWC, the DMA bus request negates until termination of the bus cycle. Should a request be pending, the arbiter may then choose to switch the bus to another master. If auto-alignment is enabled (DCR[AA] = 1), the BCR may skip over the programmed boundary. In this case, the DMA bus request will not be negated. If the BWC = 000, the request signal will remain asserted until the BCR reaches zero. In addition, an internal signal will assert to indicate that the channel has been programmed to have priority.

Note: In this arbitration scheme, the arbiter can always force the DMA to relinquish the bus.

14.7.3 CHANNEL TERMINATION

14.7.3.1 Error Conditions

When the bus encounters a read or write cycle that terminates with an error condition, the appropriate bit of the DSR is set, depending on whether the bus cycle was a read (BES) or a write (BED). The DMA transfers are then halted. If the error condition occurred during a write cycle, any data remaining in the internal holding register is lost.

14.7.3.2 Interrupts

If the INT bit of the DCR is set, the DMA will drive the appropriate slave bus interrupt signal. A processor can then read the DSR to determine if the transfer terminated successfully or with an error. The DONE bit of the DSR is then written with a 1 to clear the interrupt, along with clearing the DONE and error bits.

NOTES

Section 15

UART Modules

The MCF5249 contains two universal asynchronous/synchronous receiver/transmitters (UARTs) that act independently. Each UART is clocked by the system clock. This section applies to both UARTs, which are functionally identical. Refer to section 15.4 Register Description and Programming for addressing differences.

Each UART module, shown in Figure 15-1, consists of the following functional areas:

- Serial Communication Channel
- 16-Bit Baud-Rate Timer
- Internal Channel Control Logic
- Interrupt Control Logic

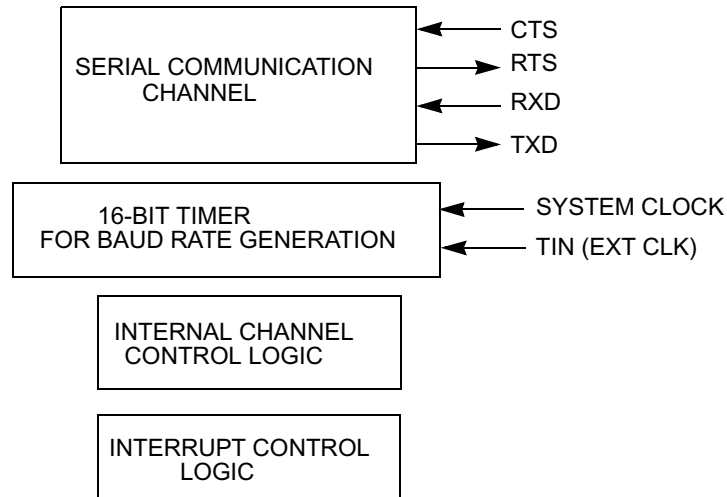

Figure 15-1 UART Block Diagram

15.1 MODULE OVERVIEW

The MCF5249 contains two independent UART modules. Features of each UART module include the following:

- UART clocked by the system clock or external clock (TIN)
- Full duplex asynchronous/synchronous receiver/transmitter channel
- Quadruple-buffered receiver
- Double-buffered transmitter
- Independently programmable receiver and transmitter clock sources:
- Programmable data format
 - Five to eight data bits plus parity
 - Odd, even, no parity, or force parity
 - .563 to 2 stop bits in x16 mode (asynchronous)/1 or 2 stop bits in synchronous mode

- Programmable channel modes:
 - Normal (full duplex)
 - Automatic echo
 - Local loopback
 - Remote loopback
- Automatic wakeup mode for multidrop applications
- Four maskable interrupt conditions
- Parity, framing, break, and overrun error detection
- False start bit detection
- Line-break detection and generation
- Detection of breaks originating in the middle of a character
- Start/end break interrupt/status

15.1.1 SERIAL COMMUNICATION CHANNEL

The communication channel provides a full duplex asynchronous/synchronous receiver and transmitter using an operating frequency derived from the system clock or from an external clock tied to the TIN pin.

The transmitter accepts parallel data from the CPU; converts it to a serial bit stream; inserts the appropriate start, stop, and optional parity bits; then outputs a composite serial data stream on the channel transmitter serial data output (TxD). Refer to [15.3.2.1 Transmitter](#) for additional information.

The receiver accepts serial data on the channel receiver serial data input (RxD); converts it to parallel format; checks for a start bit, stop bit, parity (if any), or any error condition; and transfers the assembled character onto the bus during read operations. The receiver can be polled or interrupt driven. Refer to [15.3.2.2 Receiver](#) for additional information.

15.1.2 BAUD-RATE GENERATOR/TIMER

The 16-bit timer, clocked by the system clock, can function as an asynchronous x16 clock. In addition, an external clock can be tied to one of the TIN pins of a MCF5249 timer for use as a synchronous or asynchronous clocking source for the UART. The baud-rate timer is part of each UART and not related to the ColdFire timer modules.

15.1.3 INTERRUPT CONTROL LOGIC

An internal interrupt request signal (\overline{IRQ}) notifies the MCF5249 interrupt controller of an interrupt condition. The output is the logical NOR of all (as many as four) unmasked interrupt status bits in the UART Interrupt Status Register (UISR). The UART Interrupt Mask Register (UIMR) can be programmed to determine which interrupts will be valid in the UISR.

The UART module interrupt level in the MCF5249 interrupt controller is programmed external to the UART module. The UART can be configured to supply the vector from the UART Interrupt Vector Register (UIVR) or program the SIM to provide an autovector when a UART interrupt is acknowledged.

The interrupt level, priority within the level, and autovectoring capability can also be programmed in the SIM register ICR_U1.

15.2 UART MODULE SIGNAL DEFINITIONS

The following paragraphs contain a brief description of the UART module signals. Figure 15-2 shows both the external and internal signal groups.

Note: The terms assertion and negation are used throughout this section to avoid confusion when dealing with a mixture of active-low and active-high signals. The term assert or assertion indicates that a signal is active or true, independent of the level represented by a high or low voltage. The term negate or negation indicates that a signal is inactive or false.

15.2.1 TRANSMITTER SERIAL DATA OUTPUT

The multiplexed signals TXD0/GPO27 and TXD1/GPO28 can be programmed as general purpose outputs or transmitter serial data outputs. When used as transmitters, the output is held high ("mark" condition) when the transmitter is disabled, idle, or operating in the local loopback mode. Data is shifted out on this signal on the falling edge of the clock source, with the least significant bit transmitted first.

15.2.2 RECEIVER SERIAL DATA INPUT

The multiplexed signals RXD0/GPI27 and RXD1/GPI28 can be programmed as general purpose inputs or receiver serial data inputs. When used as receivers, data received on this signal is sampled on the rising edge of the clock source, with the least significant bit received first.

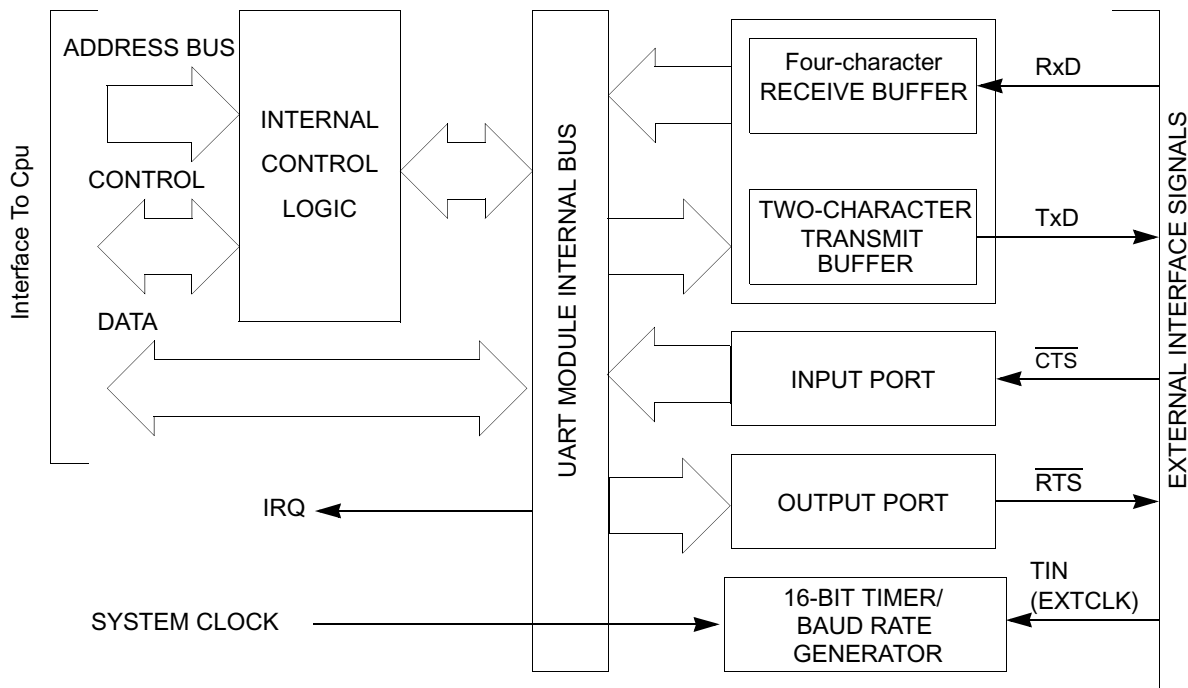

Figure 15-2 External and Internal Interface Signals

Operation

15.2.3 REQUEST-TO-SEND

The Request-To-Send (RTS) pins $\overline{\text{RTS0}}/\text{GPO30}$ and $\overline{\text{RTS1}}/\text{GPO31}$ are multiplexed with general purpose output pins. When programmed for RTS, this active-low output signal can be programmed to be automatically negated and asserted by either the receiver or transmitter. When connected to the clear-to-send (CTS) input of a transmitter, this signal controls serial data flow.

15.2.4 CLEAR-TO-SEND

The multiplexed signals $\overline{\text{CTS0}}/\text{GPI30}$ and $\overline{\text{CTS1}}/\text{GPI31}$ can be programmed as general purpose inputs or Clear-To-Send inputs. When programmed as $\overline{\text{CTS}}$, this active-low input is the clear-to-send input and can generate an interrupt on change-of-state.

15.3 OPERATION

The following sections describe the operation of the baud-rate generator, transmitter and receiver, and other operating modes of the UART module.

15.3.1 BAUD-RATE GENERATOR/TIMER

The timer references made here relative to clocking the UART are different than the MCF5249 timer module that is integrated on the bus of the ColdFire core. The UART has a baud generator based on an internal baud-rate timer that is dedicated to the UART. The Clock Select Register (USCR) can be programmed to enable the baud-rate timer or an external clock source from TIN to generate baud rates. When the baud-rate timer is used, a prescaler supplies an asynchronous 32x clock source to the baud-rate timer. The baud-rate timer register value is programmed with the UBG1 and UBG2 registers. See [15.4.1.15 Timer Upper Preload Register \(UBG1n\)](#) and [15.4.1.16 Timer Upper Preload Register 2 \(UBG2n\)](#) for more information.

An external TIN clock source, when enabled in the USCR, can generate an x1 or x16 asynchronous or synchronous clock to the UART receiver and transmitter. Figure 15-3 shows the relationship of clocking sources.

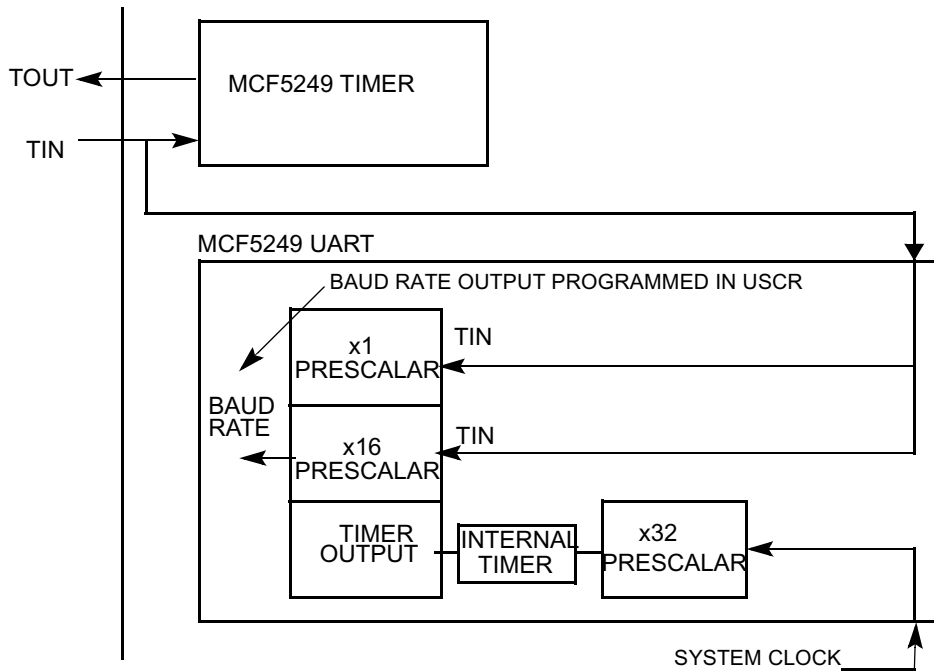

Figure 15-3 Baud-Rate Timer Generator Diagram

15.3.2 TRANSMITTER AND RECEIVER OPERATING MODES

The functional block diagram of the transmitter and receiver, including command and operating registers, is shown in Figure 15-4. The following paragraphs describe these functions in reference to this diagram. For detailed register information, refer to section 15.4 Register Description and Programming

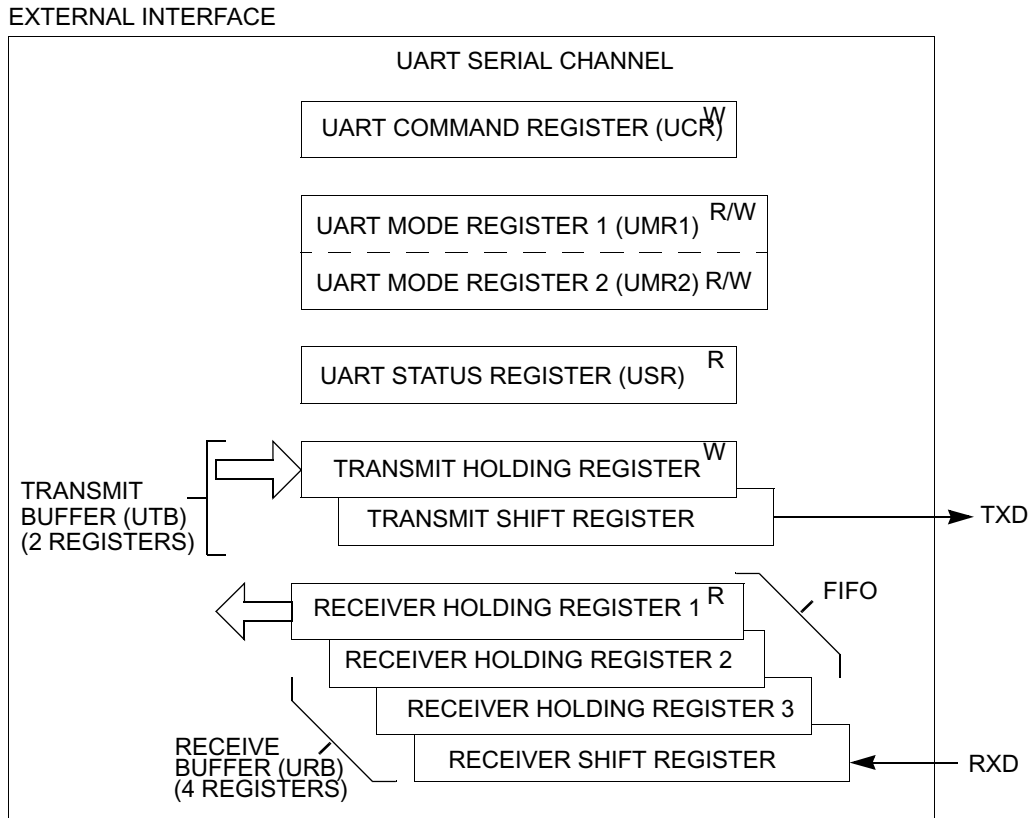

Figure 15-4 Transmitter and Receiver Functional Diagram

15.3.2.1 Transmitter

The transmitter is enabled through the UART command register (UCR) located within the UART module. The UART module signals the CPU when it is ready to accept a character by setting the transmitter-ready bit (TxRDY) in the UART status register (USR). Functional timing information for the transmitter is shown in Figure 15-5.

The transmitter converts parallel data from the CPU to a serial bit stream on TxD. It automatically sends a start bit followed by

- The programmed number of data bits
- An optional parity bit
- The programmed number of stop bits

The least significant bit is sent first. Data is shifted from the transmitter output on the falling edge of the clock source.

After the transmission of the stop bits, if a new character is not available in the transmitter holding register, the TxD output remains in the high (mark condition) state, and the transmitter-empty bit (TxEMP) in the

Operation

USR is set. Transmission resumes and the TxEMP bit is cleared when the CPU loads a new character into the UART transmitter buffer (UTB). If the transmitter receives a disable command, it continues operating until the character (if one is present) in the transmit-shift register is completely shifted out of transmitter TxD. If the transmitter is reset through a software command, operation ceases immediately (refer to section 15.4.1.5 Command Registers (UCRn)). The transmitter is re-enabled through the UCR to resume operation after a disable or software reset.

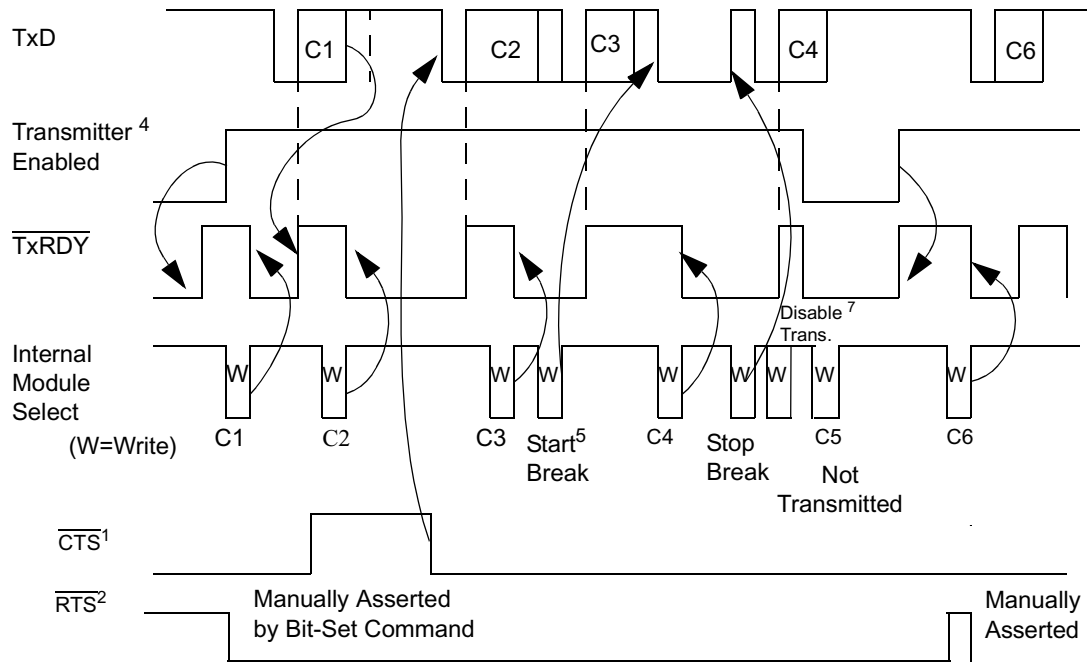

Notes:

1. Timing shown for UMR2[4]=1
2. Timing shown for UMR2[5]=1
3. CN=Transmit 8-bit character
4. Transmitter enable by configuring TCx bits in UCR (see Table 15-14)
5. Start break/Stop break programmed by MISCx bits in UCR (see Table 15-13)

Negated since transmit buffer and shift register are empty (last character has been shifted out)

Figure 15-5 Transmitter Timing Diagram

If clear-to-send operation is enabled, \overline{CTS} must be asserted for the character to be transmitted. If \overline{CTS} is negated in the middle of a transmission, the character in the shift register is transmitted and following the completion of STOP bits TxD, enters in the mark state until \overline{CTS} is asserted again. If the transmitter is forced to send a continuous low condition by issuing a Send-Break command, the transmitter ignores the state of \overline{CTS} .

Users can program the transmitter to automatically negate the request-to-send (\overline{RTS}) output on completion of a message transmission. If the transmitter is programmed to operate in this mode, \overline{RTS} must be manually asserted before a message is transmitted. In applications where the transmitter is disabled after transmission is complete and \overline{RTS} is appropriately programmed, \overline{RTS} is negated one bit time after the character in the shift register is completely transmitted. Users must manually enable the transmitter by setting the enable-transmitter bit in the UART Command Register (UCR).

15.3.2.2 Receiver

The receiver is enabled through the UCR located within the UART module. Functional timing information for the receiver is shown in Figure 15-6. The receiver looks for a high-to-low (mark-to-space) transition of the start bit on RxD. When a transition is detected, the state of RxD is sampled each 16x clock for eight clocks, starting one-half clock after the transition (asynchronous operation) or at the next rising edge of the bit time clock (synchronous operation). If RxD is sampled high, the start bit is not valid and the search for the valid start bit repeats. If RxD is still low, a valid start bit is assumed and the receiver continues to sample the input at one-bit time intervals at the theoretical center of the bit.

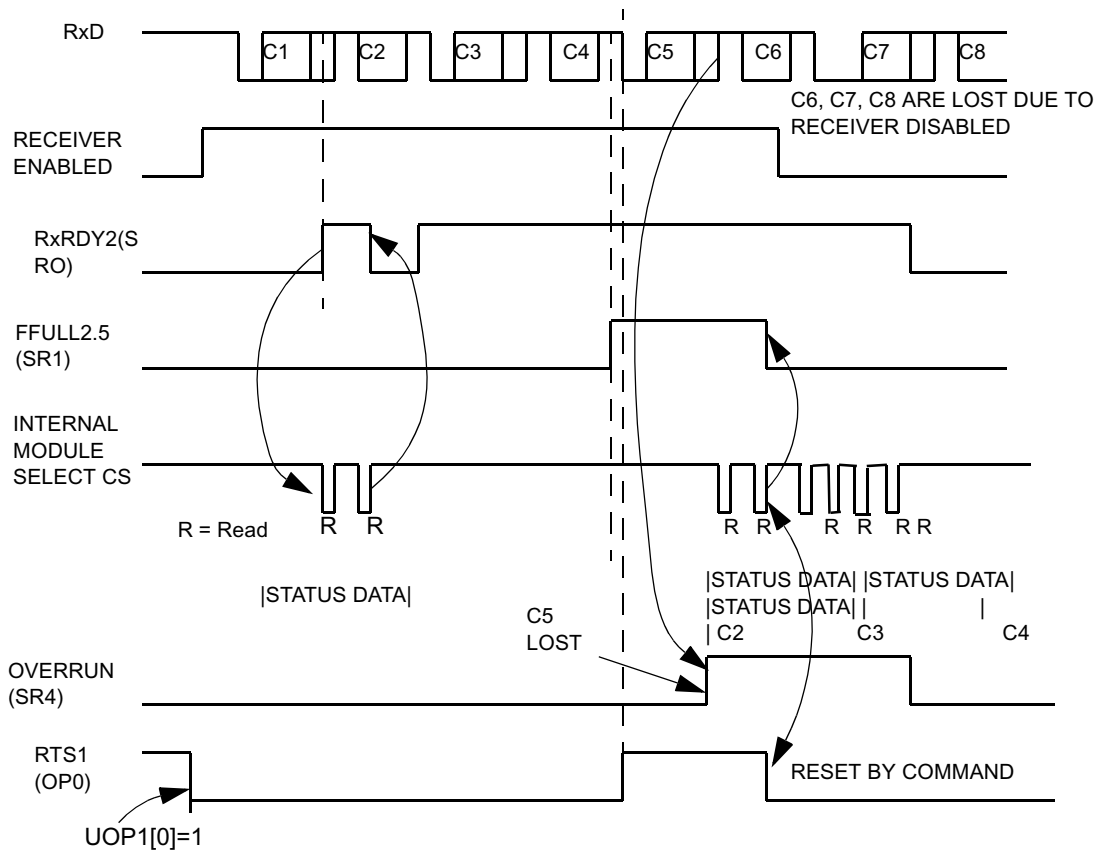

- NOTES:
1. TIMING SHOWN FOR UMR1[7]=1
 2. TIMING SHOWN FOR UMR1[6]=0
 3. CN = RECEIVED 5-8 BIT CHARACTER

Figure 15-6 Receiver Timing Diagram

This process continues until the proper number of data bits and parity (if any) is assembled and one stop bit is detected. Data on the RxD input is sampled on the rising edge of the programmed clock source. The least significant bit is received first. The data is then transferred to a receiver holding register and the RxDY bit in the USR is set. If the character length is less than eight bits, the most significant unused bits in the receiver holding register are cleared. The Rx RDY bit in the USR is set at the one-half point of the stop bit.

Operation

After the stop bit is detected, the receiver immediately looks for the next start bit. However, if a nonzero character is received without a stop bit (framing error) and RxD remains low for one-half of the bit period after the stop bit is sampled, the receiver operates as if a new start bit is detected. The parity error (PE), framing error (FE), overrun error (OE), and received break (RB) conditions (if any) set error and break flags in the USR at the received character boundary and are valid only when the RxRDY bit in the USR is set.

If a break condition is detected (RxD is low for the entire character including the stop bit), a character of all zeros is loaded into the receiver holding register and the Receive Break (RB) and RxRDY bits in the USR are set. The RxD signal must return to a high condition for at least one-half bit time before a search for the next start bit begins.

The receiver will detect the beginning of a break in the middle of a character if the break persists through the next character time. When the break begins in the middle of a character, the receiver places the damaged character in the receiver first-in-first-out (FIFO) stack and sets the corresponding error conditions and RxRDY bit in the USR. The break persists until the next character time, the receiver places an all-zero character into the receiver FIFO, and sets the corresponding RB and RxRDY bits in the USR. Interrupts can be enabled on receive break.

15.3.2.3 Receiver FIFO

The FIFO is used in the UART receiver buffer logic. The FIFO consists of three receiver holding registers. The receive buffer consists of the FIFO and a receiver shift register connected to the RxD (refer to [Figure 15-4](#)). Data is assembled in the receiver shift register and loaded into the top empty receiver holding register position of the FIFO. Thus, data flowing from the receiver to the CPU is quadruple buffered.

In addition to the data byte, three status bits, parity error (PE), framing error (FE), and received break (RB) are appended to each data character in the FIFO; overrun error (OE) is not appended. By programming the error-mode bit (ERR) in the channel's mode register (UMR1), status can be provided in character or block modes.

The RxRDY bit in the USR is set whenever one or more characters are available to be read by the CPU. A read of the receiver buffer produces an output of data from the top of the FIFO. After the read cycle, the data at the top of the FIFO and its associated status bits are "popped," and the receiver shift register can add new data at the bottom of the FIFO. The FIFO-full status bit (FFULL) is set if all three stack positions are filled with data. Either the RxRDY or FFULL bit can be selected to cause an interrupt.

Character and block modes are two error modes that can be selected within the UMR.

In the character mode, status provided in the USR is given on a character-by-character basis and thus applies only to the character at the top of the FIFO. In the block mode, the status provided in the USR is the logical OR of all characters coming to the top of the FIFO since the last reset error command. A continuous logical OR function of the corresponding status bits is produced in the USR as each character reaches the top of the FIFO.

The block mode is useful in applications where the software overhead of checking each character's error cannot be tolerated. In this mode, entire messages are received and only one data integrity check is performed at the end of the message. This mode has a data-reception speed advantage; however, each character is not individually checked for error conditions by software. If an error occurs within the message, the error is not recognized until the final check is performed, and no indication exists as to which message character is at fault.

In either mode, reading the USR does not affect the FIFO. The FIFO is popped only when the receive buffer is read. The USR should be read prior to reading the receive buffer. If all three of the FIFO receiver

holding registers are full when a new character is received, the new character is held in the receiver shift register until a FIFO position is available. If an additional character is received during this state, the contents of the FIFO are not affected. However, the previous character in the receiver shift register is lost and the OE bit in the USR is set when the receiver detects the start bit of the new overrunning character.

To support flow control capability, the receiver can be programmed to automatically negate and assert $\overline{\text{RTS}}$. When in this mode, the receiver automatically negates $\overline{\text{RTS}}$ when a valid start bit is detected and the FIFO is full. When a FIFO position becomes available, the receiver asserts $\overline{\text{RTS}}$. Using this mode of operation prevents overrun errors by connecting the $\overline{\text{RTS}}$ to the $\overline{\text{CTS}}$ input of the transmitting device.

To use the $\overline{\text{RTS}}$ signals on UART 2, the MCF5249 Pin Assignment Register (PAR) in the SIM must be set up to enable the corresponding I/O pins for these functions. If the FIFO contains characters and the receiver is disabled, the CPU can still read the characters in the FIFO. If the receiver is reset, the FIFO and all receiver status bits, corresponding output ports, and interrupt request are reset. No additional characters are received until the receiver is re-enabled.

15.3.3 LOOPING MODES

The UART can be configured to operate in various looping modes as shown in [Figure 15-7](#). These modes are useful for local and remote system diagnostic functions. The modes are described in the following paragraphs with additional information available in section [15.4 Register Description and Programming](#).

Switching between modes should only be done while the transmitter and receiver are disabled because the selected mode is activated immediately on mode selection, even if this occurs in the middle of character transmission or reception. In addition, if a mode is deselected, the device switches out of the mode immediately, except for automatic echo and remote echo loopback modes. In these modes, the deselection occurs just after the receiver has sampled the stop bit (this is also the one-half point). For automatic echo mode, the transmitter stays in this mode until the entire stop bit has been retransmitted.

15.3.3.1 Automatic Echo Mode

In this mode, the UART automatically retransmits the received data on a bit-by-bit basis. The local CPU-to-receiver communication continues normally but the CPU-to-transmitter link is disabled. While in this mode, received data is clocked on the receiver clock and retransmitted on TxD. The receiver must be enabled but not the transmitter. Instead, the transmitter is clocked by the receiver clock.

Because the transmitter is not active, the TxEMP and TxRDY bits in USR are inactive and data is transmitted as it is received. Received parity is checked but not recalculated for transmission. Character framing is also checked but stop bits are transmitted as received. A received break is echoed as received until the next valid start bit is detected.

15.3.3.2 Local Loopback Mode

In this mode, TxD is internally connected to RxD. This mode is useful for testing the operation of a local UART module channel by sending data to the transmitter and checking data assembled by the receiver. In this manner, correct channel operations can be assured. Both transmitter and CPU-to-receiver communications continue normally in this mode. While in this mode, the RxD input data is ignored, the TxD is held marking, and the receiver is clocked by the transmitter clock. The transmitter must be enabled but not the receiver.

Operation

15.3.3.3 Remote Loopback Mode

In this mode, the channel automatically transmits received data on the TxD output on a bit-by-bit basis. The local CPU-to-transmitter link is disabled. This mode is useful for testing remote channel receiver and transmitter operation. While in this mode, the receiver clocks the transmitter.

Note: Because the receiver is not active, the CPU cannot read received data. All status conditions are inactive. Received parity is not checked and is not recalculated for transmission. Stop bits are transmitted as received. A received break is echoed as received until the next valid start bit is detected.

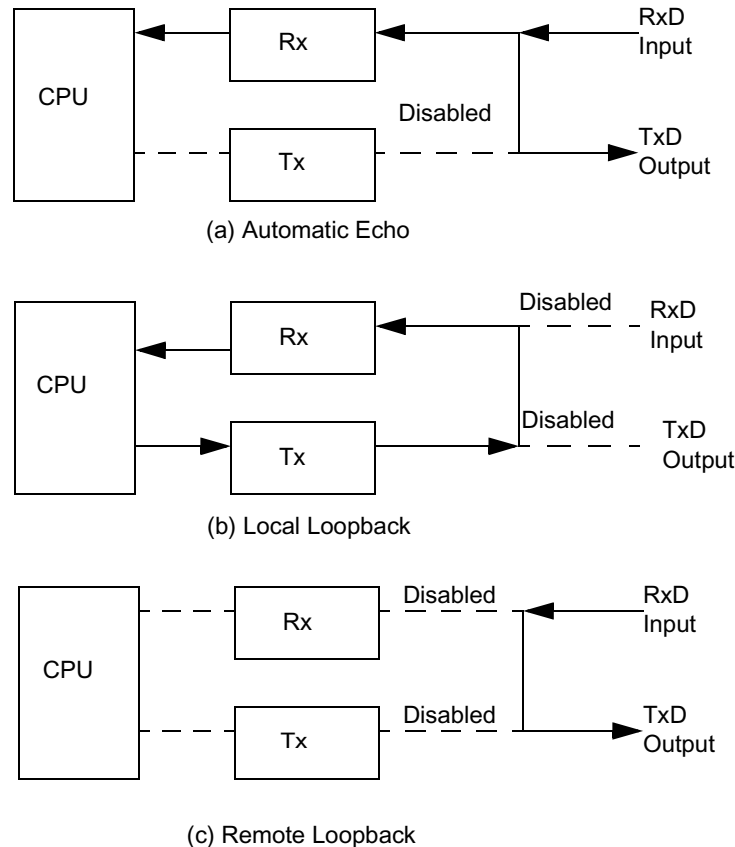

Figure 15-7 Looping Modes Functional Diagram

15.3.4 MULTIDROP MODE

The UART can be programmed to operate in a wakeup mode for multidrop or multiprocessor applications. Functional timing information for the multidrop mode is shown in Figure 15-8. The mode is selected by setting bits 3 and 4 in UART mode register 1 (UMR1). This mode of operation connects the master station to several slave stations (maximum of 256). In this mode, the master transmits an address character followed by a block of data characters targeted for one of the slave stations. The slave stations channel receivers are disabled; however, they continuously monitor the data stream sent out by the master station. When the master sends an address character, the slave receiver channel notifies its respective CPU by setting the RxRDY bit in the USR and generating an interrupt (if programmed to do so). Each slave station CPU then compares the received address to its station address and enables its receiver if it wants to

receive the subsequent data characters or block of data from the master station. Slave stations not addressed continue to monitor the data stream for the next address character. Data fields in the data stream are separated by an address character. After a slave receives a block of data, the slave station CPU disables the receiver and reinitiates the process.

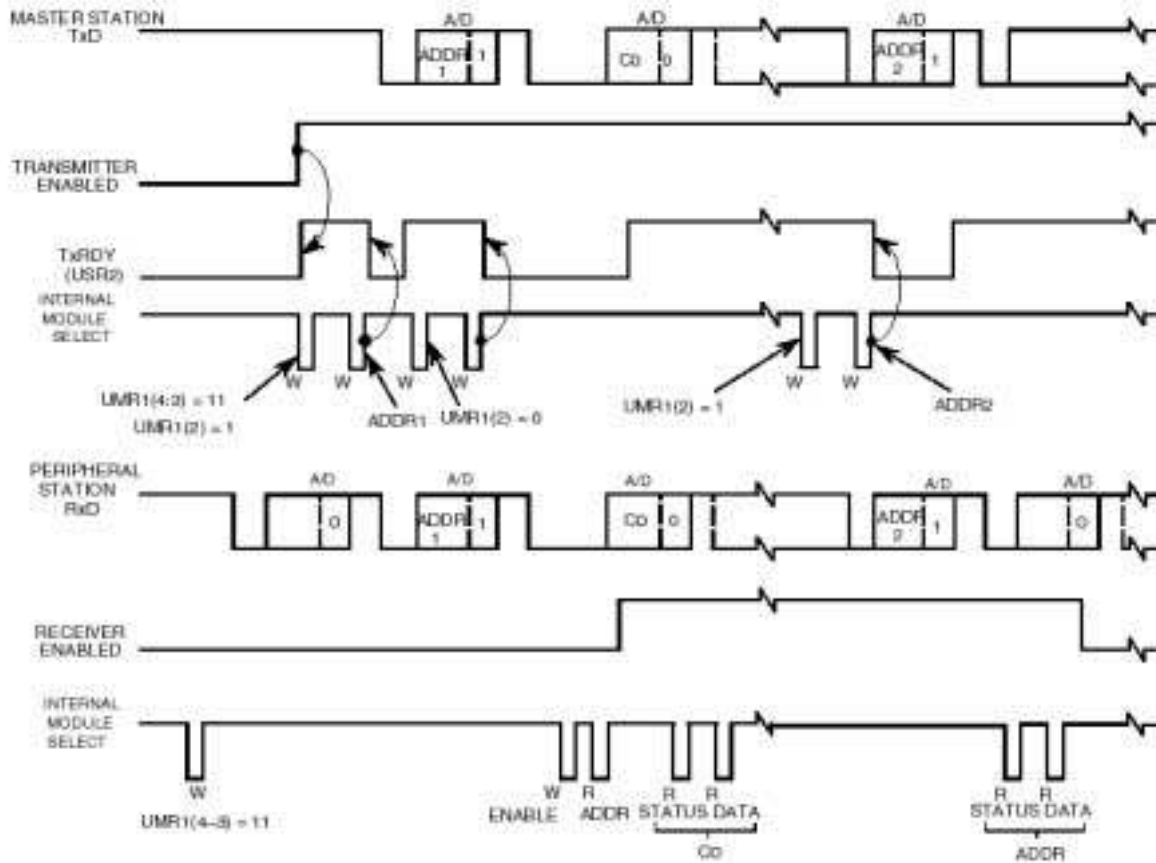

Figure 15-8 Multidrop Mode Timing Diagram

A transmitted character from the master station consists of a start bit, a programmed number of data bits, an address/data (A/D) bit flag, and a programmed number of stop bits. The A/D bit identifies the type of character being transmitted to the slave station. The character is interpreted as an address character if the A/D bit is set or as a data character if the A/D bit is cleared. The polarity of the A/D bit is selected by programming bit 2 of UMR1. UMR1 should also be programmed before enabling the transmitter and loading the corresponding data bits into the transmit buffer.

In multidrop mode, the receiver continuously monitors the received data stream, regardless of whether it is enabled or disabled. If the receiver is disabled, it sets the RxRDY bit and loads the character into the receiver holding register FIFO, provided the received A/D bit is a one (address tag). The character is discarded if the received A/D bit is a zero (data tag). If the receiver is enabled, all received characters are transferred to the CPU using the receiver holding register stack during read operations.

In either case, the data bits are loaded into the data portion of the stack while the A/D bit is loaded into the status portion of the stack normally used for a parity error (USR bit 5). Framing error, overrun error, and

break detection operate normally. The A/D bit takes the place of the parity bit; therefore, parity is neither calculated nor checked. Messages in this mode can still contain error detection and correction information. One way to provide error detection, if 8-bit characters are not required, is to use software to calculate parity and append it to the 5-, 6-, or 7-bit character.

15.3.5 BUS OPERATION

This section describes the operation of the bus during read, write, and interrupt-acknowledge cycles to the UART module. All UART module registers must be accessed as bytes.

15.3.5.1 Read Cycles

The CPU accesses the UART module with 1 to 2 wait states because the core system clock is divided by 2 for the UART module. The UART module responds to reads with byte data on D[7:0]. Reserved registers return logic zero during reads.

15.3.5.2 Write Cycles

The CPU with zero wait states accesses the UART module. The UART module accepts write data on D[7:0]. Write cycles to read-only registers and reserved registers complete in a normal manner without exception processing; however, the data is ignored.

15.3.5.3 Interrupt Acknowledge Cycles

The UART module can arbitrate for interrupt servicing and supply the interrupt vector when it has successfully won arbitration. The vector number must be provided if interrupt servicing is necessary; thus, the interrupt vector register (UIVR) must be initialized. The interrupt vector number generated by the IVR is used if the autovector is not enabled in the SIM Interrupt Control Register (ICR). If the UIVR is not initialized and the ICR is not programmed for autovector, a spurious interrupt exception is taken if interrupts are generated. This works in conjunction with the MCF5249 interrupt controller, which allows a programmable Interrupt Priority Level (IPL) for the interrupt.

15.4 REGISTER DESCRIPTION AND PROGRAMMING

This section contains a detailed description of each register and its specific function as well as flowcharts of basic UART module programming.

15.4.1 REGISTER DESCRIPTION

Writing control bytes into the appropriate registers controls the UART operation. A list of UART module registers and their associated addresses is shown in [Table 15-1](#).

Note: All UART module registers are accessible only as bytes. The contents of the mode registers (UMR1 and UMR2), clock-select register (UCSR), and the auxiliary control register (UACR) bit 7 should be changed only after the receiver/transmitter is issued a software RESET command—i.e., channel operation must be disabled. Be careful if the register contents are changed during receiver/transmitter operations because unpredictable results can occur.

For the registers described in this section, the numbers above the register description represent the bit position in the register. The register description contains the mnemonic for the bit. The values as shown in the following tables are the values of those register bits after a hardware reset. A value of U indicates that the bit value is unaffected by reset. The read/write status is shown in the last line.

Table 15-1 UART Module Programming Model

UART 0	UART 1	REGISTER READ (R/W = 1)	REGISTER WRITE (R/W = 0)
MBAR+\$1C0	MBAR+\$200	Mode Register (UMR1, UMR2)	Mode Register (UMR1, UMR2)
MBAR+\$1C4	MBAR+\$204	Status Register (USR)	Clock-Select Register (UCSR)
MBAR+\$1C8	MBAR+\$208	DO NOT ACCESS ¹	Command Register (UCR)
MBAR+\$1CC	MBAR+\$20C	Receiver Buffer (URB)	Transmitter Buffer (UTB)
MBAR+\$1D0	MBAR+\$210	Input Port Change Register (UIPCR)	Auxiliary Control Register (UACR)
MBAR+\$1D4	MBAR+\$214	Interrupt Status Register (UISR)	Interrupt Mask Register (UIMR)
MBAR+\$1D8	MBAR+\$218	Baud Rate Generator Prescale MSB (UBG1)	Baud Rate Generator Prescale MSB (UBG1)
MBAR+\$1DC	MBAR+\$21C	Baud Rate Generator Prescale LSB (UBG2)	Baud Rate Generator Prescale LSB (UBG2)
		DO NOT ACCESS ¹	
MBAR+\$1F0	MBAR+\$230	Interrupt Vector Register (UIVR)	Interrupt Vector Register (UIVR)
MBAR+\$1F4	MBAR+\$234	Input Port Register (UIP)	DO NOT ACCESS ¹
MBAR+\$1F8	MBAR+\$238	DO NOT ACCESS ¹	Output Port Bit Set CMD (UOP1) ²
MBAR+\$1FC	MBAR+\$23C	DO NOT ACCESS ¹	Output Port Bit Reset CMD (UOP0) ²

Note: 1. This address is used for factory testing and should not be read. Reading this location results in undesired effects and possible incorrect transmission or reception of characters. Register contents can also be changed.

Note: 2. Address-triggered commands.

15.4.1.1 Mode Register 1 (UMR1n)

The UMR1 controls some of the UART module configuration. This register can be read or written at any time and is accessed when the mode register pointer points to UMR1. The pointer is set to UMR1 by RESET or by a set pointer command using the control register. After reading or writing UMR1, the pointer points to UMR2.

Table 15-2 Mode Register 1

BITS	7	6	5	4	3	2	1	0
FIELD	RXRTS	RXIRQ	ERR	PM1	PM0	PT	B/C1	B/C0
RESET	0	0	0	0	0	0	0	0
R/W	READ/WRITE SUPERVISOR OR USER							
ADDR	MBAR + \$1C0 (UMR10) MBAR + \$200 (UMR11)							

Table 15-3 Mode Register 1 Bit Descriptions

BIT NAME	DESCRIPTION																																								
RxRTS	<p>Receiver Request-to-Send Control</p> <p>1 = On receipt of a valid start bit, \overline{RTS} is negated if the UART FIFO is full. \overline{RTS} is reasserted when the FIFO has an empty position available.</p> <p>0 = The receiver has no effect on \overline{RTS}. The \overline{RTS} is asserted by writing a one to the Output Port Bit Set Register (UOP1)</p> <p>This feature can be used for flow control to prevent overrun in the receiver by using the \overline{RTS} output to control the \overline{CTS} input of the transmitting device. If both the receiver and transmitter are programmed for \overline{RTS} control, \overline{RTS} control is disabled for both because such a configuration is incorrect.</p>																																								
RxIRQ	<p>On UART 2, \overline{RRxIRQ} — Receiver Interrupt Select</p> <p>1 = FFULL is the source that generates IRQ</p> <p>0 = RxRDY is the source that generates IRQ</p>																																								
ERR	<p>The Error Mode bit controls the meaning of the three FIFO status bits (RB, FE, and PE) in the USR.</p> <p>1 = Block mode—The values in the channel USR are the accumulation (i.e., the logical OR) of the status for all characters coming to the top of the FIFO since the last reset error status command for the channel was issued. Refer to 15.4.1.5 Command Registers (UCRn) for more information on UART module commands.</p> <p>0 = Character mode—The values in the channel USR reflect the status of the character at the top of the FIFO.</p> <p>ERR = 0 must be used to obtain the correct A/\overline{D} flag information when in multidrop mode.</p>																																								
PM1–PM0	<p>The Parity Mode bits encode the type of parity used for the channel (see Table 15-4). The parity bit is added to the transmitted character and the receiver performs a parity check on incoming data. These bits can alternatively select multidrop mode for the channel.</p>																																								
PT	<p>The Parity Type bit selects the parity type if parity is programmed by the parity mode bits; if multidrop mode is selected, it configures the transmitter for data character transmission or address character transmission. Table 15-4 lists the parity mode and type or the multidrop mode for each combination of the parity mode and the parity type bits.</p> <p align="center">Table 15-4 PMx and PT Control Bits</p> <table border="1"> <thead> <tr> <th align="center">PM1</th> <th align="center">PM0</th> <th align="center">PARITY MODE</th> <th align="center">PT</th> <th align="center">PARITY TYPE</th> </tr> </thead> <tbody> <tr> <td align="center">0</td> <td align="center">0</td> <td align="center">With Parity</td> <td align="center">0</td> <td align="center">Even Parity</td> </tr> <tr> <td align="center">0</td> <td align="center">0</td> <td align="center">With Parity</td> <td align="center">1</td> <td align="center">Odd Parity</td> </tr> <tr> <td align="center">0</td> <td align="center">1</td> <td align="center">Force Parity</td> <td align="center">0</td> <td align="center">Low Parity</td> </tr> <tr> <td align="center">0</td> <td align="center">1</td> <td align="center">Force Parity</td> <td align="center">1</td> <td align="center">High Parity</td> </tr> <tr> <td align="center">1</td> <td align="center">0</td> <td align="center">No Parity</td> <td align="center">X</td> <td align="center">No Parity</td> </tr> <tr> <td align="center">1</td> <td align="center">1</td> <td align="center">Multidrop Mode</td> <td align="center">0</td> <td align="center">Data Character</td> </tr> <tr> <td align="center">1</td> <td align="center">1</td> <td align="center">Multidrop Mode</td> <td align="center">1</td> <td align="center">Address Character</td> </tr> </tbody> </table> <p>Note: "Force parity low" means forcing a 0 parity bit. "Force parity high" forces a 1 parity bit.</p>	PM1	PM0	PARITY MODE	PT	PARITY TYPE	0	0	With Parity	0	Even Parity	0	0	With Parity	1	Odd Parity	0	1	Force Parity	0	Low Parity	0	1	Force Parity	1	High Parity	1	0	No Parity	X	No Parity	1	1	Multidrop Mode	0	Data Character	1	1	Multidrop Mode	1	Address Character
PM1	PM0	PARITY MODE	PT	PARITY TYPE																																					
0	0	With Parity	0	Even Parity																																					
0	0	With Parity	1	Odd Parity																																					
0	1	Force Parity	0	Low Parity																																					
0	1	Force Parity	1	High Parity																																					
1	0	No Parity	X	No Parity																																					
1	1	Multidrop Mode	0	Data Character																																					
1	1	Multidrop Mode	1	Address Character																																					

Table 15-3 Mode Register 1 Bit Descriptions (Continued)

BIT NAME	DESCRIPTION															
B/C1–B/C0	<p>The Bits per Character bits select the number of data bits per character to be transmitted. The character length listed in Table 15-5 does not include start, parity, or stop bits.</p> <p style="text-align: center;">Table 15-5 B/Cx Control Bits</p> <table border="1" style="margin-left: auto; margin-right: auto;"> <thead> <tr> <th data-bbox="662 434 769 478">B/C1</th> <th data-bbox="769 434 867 478">B/C0</th> <th data-bbox="867 434 1174 478">BITS/CHARACTER</th> </tr> </thead> <tbody> <tr> <td data-bbox="662 478 769 527">0</td> <td data-bbox="769 478 867 527">0</td> <td data-bbox="867 478 1174 527">5 Bits</td> </tr> <tr> <td data-bbox="662 527 769 575">0</td> <td data-bbox="769 527 867 575">1</td> <td data-bbox="867 527 1174 575">6 Bits</td> </tr> <tr> <td data-bbox="662 575 769 623">1</td> <td data-bbox="769 575 867 623">0</td> <td data-bbox="867 575 1174 623">7 Bits</td> </tr> <tr> <td data-bbox="662 623 769 672">1</td> <td data-bbox="769 623 867 672">1</td> <td data-bbox="867 623 1174 672">8 Bits</td> </tr> </tbody> </table>	B/C1	B/C0	BITS/CHARACTER	0	0	5 Bits	0	1	6 Bits	1	0	7 Bits	1	1	8 Bits
B/C1	B/C0	BITS/CHARACTER														
0	0	5 Bits														
0	1	6 Bits														
1	0	7 Bits														
1	1	8 Bits														

15.4.1.2 Mode Register 2 (UMR2n)

UART mode registers 2 (UMR2n) control UART module configuration. UMR2n can be read or written when the mode register pointer points to it, which occurs after any access to UMR1n. UMR2n accesses do not update the pointer.

Table 15-6 Mode Register 2

BITS	7	6	5	4	3	2	1	0
FIELD	CM		TXRTS	TXCTS	SB			
RESET	0	0	0	0	0	0	0	0
R/W	READ/WRITE SUPERVISOR OR USER							
ADDR	MBAR + \$1C0 MBAR + \$200							

Table 15-7 Mode Register 2 Bit Descriptions

BIT NAME	DESCRIPTION
CM	<p>Channel mode.</p> <p>Selects a channel mode. Section 16.5.3, "Looping Modes," describes individual modes.</p> <p>00 Normal 01 Automatic echo 10 Local loop-back 11 Remote loop-back</p>
TxRTS	<p>Transmitter ready-to-send.</p> <p>Controls negation of RTS to automatically terminate a message transmission when the transmitter is disabled after completion of a transmission. Attempting to program a receiver and transmitter in the same channel for RTS control is not permitted and disables RTS control for both.</p> <p>0 The transmitter has no effect on RTS. 1 When the transmitter is disabled after transmission completes, setting this bit automatically clears UOP[RTS] one bit time after any characters in the channel transmitter shift and holding registers are completely sent, including the programmed number of stop bits.</p>
TxCTS	<p>Transmitter clear-to-send.</p> <p>If both TxCTS and TxRTS are enabled, TxCTS controls the operation of the transmitter.</p> <p>0 CTS has no effect on the transmitter. 1 Enables clear-to-send operation. The transmitter checks the state of CTS each time it is ready to send a character. If CTS is asserted, the character is sent; if it is negated, the channel TxD remains in the high state and transmission is delayed until CTS is asserted. Changes in CTS as a character is being sent do not affect its transmission.</p>

Table 15-7 Mode Register 2 Bit Descriptions

BIT NAME	DESCRIPTION																																																												
SB	<p>Stop-bit length control.</p> <p>Selects the length of the stop bit appended to the transmitted character. Stop-bit lengths of 9/16th to 2 bits are programmable for 6–8 bit characters. Lengths of 1 1/16th to 2 bits are programmable for 5-bit characters. In all cases, the receiver checks only for a high condition at the center of the first stop-bit position, that is, one bit time after the last data bit or after the parity bit, if parity is enabled. If an external 1x clock is used for the transmitter, clearing bit 3 selects one stop bit and setting bit 3 selects 2 stop bits for transmission.</p> <table border="1" data-bbox="375 554 865 791"> <thead> <tr> <th>SB</th> <th>5 BITS</th> <th>6 -8 BITS</th> </tr> </thead> <tbody> <tr> <td>0000</td> <td>1.063</td> <td>0.563</td> </tr> <tr> <td>0001</td> <td>1.125</td> <td>0.625</td> </tr> <tr> <td>0010</td> <td>1.188</td> <td>0.688</td> </tr> <tr> <td>0011</td> <td>1.250</td> <td>0.750</td> </tr> </tbody> </table> <table border="1" data-bbox="375 863 865 1100"> <thead> <tr> <th>SB</th> <th>5 BITS</th> <th>6 -8 BITS</th> </tr> </thead> <tbody> <tr> <td>0100</td> <td>1.313</td> <td>0.813</td> </tr> <tr> <td>0101</td> <td>1.375</td> <td>0.875</td> </tr> <tr> <td>0110</td> <td>1.438</td> <td>0.938</td> </tr> <tr> <td>0111</td> <td>1.500</td> <td>1.000</td> </tr> </tbody> </table> <table border="1" data-bbox="375 1180 865 1417"> <thead> <tr> <th>SB</th> <th>5 BITS</th> <th>6 -8 BITS</th> </tr> </thead> <tbody> <tr> <td>1000</td> <td>1.563</td> <td>1.563</td> </tr> <tr> <td>1001</td> <td>1.625</td> <td>1.625</td> </tr> <tr> <td>1010</td> <td>1.688</td> <td>1.688</td> </tr> <tr> <td>1011</td> <td>1.750</td> <td>1.750</td> </tr> </tbody> </table> <table border="1" data-bbox="375 1503 865 1740"> <thead> <tr> <th>SB</th> <th>5 BITS</th> <th>6 -8 BITS</th> </tr> </thead> <tbody> <tr> <td>1100</td> <td>1.813</td> <td>1.813</td> </tr> <tr> <td>1101</td> <td>1.875</td> <td>1.875</td> </tr> <tr> <td>1110</td> <td>1.938</td> <td>1.938</td> </tr> <tr> <td>1111</td> <td>2.000</td> <td>2.000</td> </tr> </tbody> </table>	SB	5 BITS	6 -8 BITS	0000	1.063	0.563	0001	1.125	0.625	0010	1.188	0.688	0011	1.250	0.750	SB	5 BITS	6 -8 BITS	0100	1.313	0.813	0101	1.375	0.875	0110	1.438	0.938	0111	1.500	1.000	SB	5 BITS	6 -8 BITS	1000	1.563	1.563	1001	1.625	1.625	1010	1.688	1.688	1011	1.750	1.750	SB	5 BITS	6 -8 BITS	1100	1.813	1.813	1101	1.875	1.875	1110	1.938	1.938	1111	2.000	2.000
SB	5 BITS	6 -8 BITS																																																											
0000	1.063	0.563																																																											
0001	1.125	0.625																																																											
0010	1.188	0.688																																																											
0011	1.250	0.750																																																											
SB	5 BITS	6 -8 BITS																																																											
0100	1.313	0.813																																																											
0101	1.375	0.875																																																											
0110	1.438	0.938																																																											
0111	1.500	1.000																																																											
SB	5 BITS	6 -8 BITS																																																											
1000	1.563	1.563																																																											
1001	1.625	1.625																																																											
1010	1.688	1.688																																																											
1011	1.750	1.750																																																											
SB	5 BITS	6 -8 BITS																																																											
1100	1.813	1.813																																																											
1101	1.875	1.875																																																											
1110	1.938	1.938																																																											
1111	2.000	2.000																																																											

Freescale Semiconductor, Inc.

Register Description and Programming

15.4.1.3 Status Registers (USRn)

The USR registers indicate the status of the characters in the receive FIFO and the status of the transmitter and receiver. The RB, FE, and PE bits are cleared by the Reset Error Status command in the UCR registers if the RB bit has not been read. Also, RB, FE, PE and OE can also be cleared by reading the Receive buffer (URB).

Table 15-8 Status Registers (USR0 and USR1)

BITS	7	6	5	4	3	2	1	0
FIELD	RB	FE	PE	OE	TXEMP	TXRDY	FFULL	RXRDY
RESET	0	0	0	0	0	0	0	0
R/W	READ/WRITE SUPERVISOR OR USER							
ADDR	MBAR + \$1C4 (USR0) MBAR + \$204 (USR1)							

Table 15-9 Status Bit Descriptions

BIT NAME	DESCRIPTION
RB	Received Break 1 = An all-zero character of the programmed length has been received without a stop bit. The RB bit is valid only when the RxRDY bit is set. A single FIFO position is occupied when a break is received. Additional entries into the FIFO are inhibited until RxRDY returns to the high state for at least one-half bit time, which is equal to two successive edges of the internal or external clock x 1 or 16 successive edges of the external clock x 16. The received break circuit detects breaks that originate in the middle of a received character. However, if a break begins in the middle of a character, it must persist until the end of the next detected character time. 0 = No break has been received.
FE	Framing Error 1 = A stop bit was not detected when the corresponding data character in the FIFO was received. The stop-bit check occurs in the middle of the first stop-bit position. The bit is valid only when the RxRDY bit is set. 0 = No framing error has occurred.
PE	Parity Error 1 = When the with-parity or force-parity mode is programmed in the UMR1, the corresponding character in the FIFO was received with incorrect parity. When the multidrop mode is programmed, this bit stores the received A/D bit. This bit is valid only when the RxRDY bit is set. 0 = No parity error has occurred.
OE	Overrun Error 1 = One or more characters in the received data stream have been lost. This bit is set on receipt of a new character when the FIFO is full and a character is already in the shift register waiting for an empty FIFO position. When this occurs, the character in the receiver-shift register and its break-detect, framing-error status, and parity error, if any, are lost. The reset-error status command in the UCR clears this bit. 0 = No overrun has occurred.

Table 15-9 Status Bit Descriptions (Continued)

BIT NAME	DESCRIPTION
TxEMP	Transmitter Empty 1 = The transmitter has underrun (both the transmitter holding register and transmitter shift registers are empty). This bit is set after transmission of the last stop bit of a character if there are no characters in the transmitter-holding register awaiting transmission. 0 = The transmitter buffer is not empty. Either a character is currently being shifted out or the transmitter is disabled. Users can enable/disable the transmitter by programming the TCx bits in the UCR.
TxRDY	Transmitter Ready 1 = The transmitter-holding register is empty and ready to be loaded with a character. This bit is set when the character is transferred to the transmitter shift register. This bit is also set when the transmitter is first enabled. Characters loaded into the transmitter holding register while the transmitter is disabled are not transmitted. 0 = The CPU has loaded the transmitter-holding register or the transmitter is disabled.
FFULL	FIFO Full 1 = Three characters have been received and are waiting in the receiver buffer FIFO. 0 = The FIFO is not full but can contain as many as two unread characters.
RxRDY	Receiver Ready 1 = One or more characters have been received and are waiting in the receiver buffer FIFO. 0 = The CPU has read the receiver buffer and no characters remain in the FIFO after this read.

15.4.1.4 Clock-Select Registers (UCSRn)

The UCSR registers select the internal clock (timer mode) or the external clock in synchronous or asynchronous mode. To use the timer mode for either the receiver and transmitter channel, program the UCSR registers to the value \$DD.

The transmitter and receiver can be programmed to different clock sources.

Table 15-10 Clock Select Register (UCSRn)

BITS	7	6	5	4	3	2	1	0
FIELD	RCS3	RCS2	RCS1	RCS0	TCS3	TCS2	TCS1	TCS0
RESET	1	1	0	1	1	1	0	1
R/W	WRITE ONLY							
ADDR	MBAR + \$1C4 MBAR + \$204							

Table 15-11 Clock Select Bit Descriptions

BIT NAME	DESCRIPTION																				
RCS3–RCS0	<p>The Receiver Clock Select bits select the clock source for the receiver channel. Table 15-11 details the register bits necessary for each mode.</p> <table border="1"> <thead> <tr> <th>RCS3</th> <th>RCS2</th> <th>RCS1</th> <th>RCS0</th> <th>MODE</th> </tr> </thead> <tbody> <tr> <td>1</td> <td>1</td> <td>0</td> <td>1</td> <td>TIMER</td> </tr> <tr> <td>1</td> <td>1</td> <td>1</td> <td>0</td> <td>Ext. clk. x 16</td> </tr> <tr> <td>1</td> <td>1</td> <td>1</td> <td>1</td> <td>Ext. clk. x 1</td> </tr> </tbody> </table>	RCS3	RCS2	RCS1	RCS0	MODE	1	1	0	1	TIMER	1	1	1	0	Ext. clk. x 16	1	1	1	1	Ext. clk. x 1
RCS3	RCS2	RCS1	RCS0	MODE																	
1	1	0	1	TIMER																	
1	1	1	0	Ext. clk. x 16																	
1	1	1	1	Ext. clk. x 1																	
TCS3–TCS0	<p>The Transmitter Clock Select bits determine the clock source of the UART transmitter channel.</p> <table border="1"> <thead> <tr> <th>TCS3</th> <th>TCS2</th> <th>TCS1</th> <th>TCS0</th> <th>SET 1</th> </tr> </thead> <tbody> <tr> <td>1</td> <td>1</td> <td>0</td> <td>1</td> <td>TIMER</td> </tr> <tr> <td>1</td> <td>1</td> <td>1</td> <td>0</td> <td>Ext. clk. x 16</td> </tr> <tr> <td>1</td> <td>1</td> <td>1</td> <td>1</td> <td>Ext. clk. x 1</td> </tr> </tbody> </table>	TCS3	TCS2	TCS1	TCS0	SET 1	1	1	0	1	TIMER	1	1	1	0	Ext. clk. x 16	1	1	1	1	Ext. clk. x 1
TCS3	TCS2	TCS1	TCS0	SET 1																	
1	1	0	1	TIMER																	
1	1	1	0	Ext. clk. x 16																	
1	1	1	1	Ext. clk. x 1																	

15.4.1.5 Command Registers (UCRn)

The UCR supplies commands to the UART. Multiple commands can be specified in a single write to the UCR if the commands are not conflicting. For example, reset-transmitter and enable-transmitter commands cannot be specified in a single command.

Table 15-12 Command Register (UCRn)

BITS	7	6	5	4	3	2	1	0
FIELD	—	MISC2	MISC1	MISC0	TC1	TC0	RC1	RC0
RESET	0	0	0	0	0	0	0	0
R/W	WRITE ONLY							
ADDR	MBAR + \$1C8 (UCR0) MBAR + \$208 (UCR1)							

15.4.1.6 Miscellaneous Commands

Bits MISC3 through MISC0 select a single command as listed in [Table 15-13](#).

Table 15-13 MISCx Control Bits

MISC2	MISC1	MISC0	COMMAND
0	0	0	No Command
0	0	1	Reset Mode Register Pointer
0	1	0	Reset Receiver
0	1	1	Reset Transmitter

Table 15-13 MISCx Control Bits (Continued)

MISC2	MISC1	MISC0	COMMAND
1	0	0	Reset Error Status
1	0	1	Reset Break-Change Interrupt
1	1	0	Start Break
1	1	1	Stop Break

15.4.1.6.1 Reset Mode Register Pointer

The reset mode register pointer command causes the mode register pointer to point to UMR1.

15.4.1.6.2 Reset Receiver

The reset receiver command resets the receiver. The receiver is immediately disabled, the FFULL and RxRDY bits in the USR are cleared, and the receiver FIFO pointer is reinitialized. All other registers are unaltered. Use this command instead of the receiver-disable command whenever the receiver configuration is changed (it places the receiver in a known state).

15.4.1.6.3 Reset Transmitter

The reset transmitter command resets the transmitter. The transmitter is immediately disabled and the TxEMP and TxRDY bits in the USR are cleared. All other registers are unaltered. Use this command instead of the transmitter-disable command whenever the transmitter configuration is changed (it places the transmitter in a known state).

15.4.1.6.4 Reset Error Status

The reset error status command clears the RB, FE, PE, and OE bits in the USR. This command is also used in the block mode to clear all error bits after a data block is received.

15.4.1.6.5 Reset Break-Change Interrupt

The reset break-change interrupt command clears the delta break (DBx) bit in the UISR.

15.4.1.6.6 Start Break

The start break command forces TxD low. If the transmitter is empty, the start of the break conditions can be delayed by as much as two bit times. If the transmitter is active, the break begins when transmission of the character is complete. If a character is in the transmitter shift register, the start of the break is delayed until the character is transmitted. If the transmitter holding register has a character, that character is transmitted before the break. The transmitter must be enabled for this command to be accepted. The state of the $\overline{\text{CTS}}$ input is ignored for this command.

15.4.1.6.7 Stop Break

The stop break command causes TxD to go high (mark) within two bit times. Characters stored in the transmitter buffer, if any, are transmitted.

15.4.1.7 Transmitter Commands

Bits TC1 and TC0 select a single command as listed in [Table 15-14](#).

Table 15-14 TCx Control Bits

TC1	TC0	COMMAND
0	0	No Action Taken
0	1	Transmitter Enable
1	0	Transmitter Disable
1	1	Do Not Use

15.4.1.7.1 No Action Taken

The “no action taken” command causes the transmitter to stay in its current mode. If the transmitter is enabled, it remains enabled; if disabled, it remains disabled.

15.4.1.7.2 Transmitter Enable

The “transmitter enable” command enables operation of the channel's transmitter. The TxEMP and TxRDY bits in the USR are also set. If the transmitter is already enabled, this command has no effect.

15.4.1.7.3 Transmitter Disable

The “transmitter disable” command terminates transmitter operation and clears the TxEMP and TxRDY bits in the USR. However, if a character is being transmitted when the transmitter is disabled, the transmission of the character is completed before the transmitter becomes inactive. If the transmitter is already disabled, this command has no effect.

15.4.1.7.4 Do Not Use

Do not use this bit combination because the result is indeterminate.

15.4.1.8 Receiver Commands

Bits RC1 and RC0 select a single command as listed in [Table 15-15](#).

Table 15-15 RCx Control Bits

RC1	RC0	COMMAND
0	0	No Action Taken
0	1	Receiver Enable
1	0	Receiver Disable
1	1	Do Not Use

15.4.1.8.1 No Action Taken

The “no action taken” command causes the receiver to stay in its current mode. If the receiver is enabled, it remains enabled; if disabled, it remains disabled.

15.4.1.8.2 Receiver Enable

The “receiver enable” command enables operation of the channel's receiver. If the UART module is not in multidrop mode, this command also forces the receiver into the search-for-start-bit state. If the receiver is already enabled, this command has no effect.

15.4.1.8.3 Receiver Disable

The “receiver disable” command immediately disables the receiver. Any character being received is lost. The command has no effect on the receiver status bits or any other control register. If the UART module is programmed to operate in the local loopback mode or multidrop mode, the receiver operates even though this command is selected. If the receiver is already disabled, this command has no effect.

15.4.1.8.4 Do Not Use

Do not use this bit combination because the result is indeterminate.

15.4.1.9 Receiver Buffer Registers (UBRn)

The receiver buffer (URB) contains three receiver-holding registers and a serial shift register. The Rx/D pin is connected to the serial shift register while the holding registers act as a FIFO. The CPU reads from the top of the stack while the receiver shifts and updates from the bottom of the stack when the shift register has been filled (see [Figure 15-4](#)).

Table 15-16 Receiver Buffer (URBn)

BITS	7	6	5	4	3	2	1	0
FIELD	RB7	RB6	RB5	RB4	RB3	RB2	RB1	RB0
RESET	1	1	1	1	1	1	1	1
R/W	READ ONLY							
ADDR	MBAR + \$1CC MBAR + \$20C							

Table 15-17 Receiver Buffer Bit Descriptions

BIT NAME	DESCRIPTION
RB7–RB0	These bits contain the character in the receiver buffer.

15.4.1.10 Transmitter Buffer Registers (UTBn)

The transmitter buffer (UTB) consists of two registers: the transmitter-holding register and the transmitter shift register (see [Figure 15-4](#)). The holding register accepts characters from the bus master if the TxRDY bit in the channel's USR is set. A write to the transmitter buffer clears the TxRDY bit, inhibiting additional characters until the shift register is ready to accept more data. When the shift register is empty, it checks the holding register for a valid character to be sent (TxRDY bit cleared). If a valid character is present, the shift register loads the character and reasserts the TxRDY bit in the USR. Writes to the transmitter buffer when the channel's UART Status Register (USR) TxRDY bit is clear and when the transmitter is disabled have no effect on the transmitter buffer.

Table 15-18 Transmitter Buffer (UTBn)

BITS	7	6	5	4	3	2	1	0
FIELD	TB7	TB6	TB5	TB4	TB3	TB2	TB1	TB0
RESET	0	0	0	0	0	0	0	0
R/W	WRITE ONLY							
ADDR	MBAR + \$1CC MBAR + \$20C							

Table 15-19 Transmitter Buffer Bit Descriptions

BIT NAME	DESCRIPTION
TB7–TB0	These bits contain the character in the transmitter buffer.

15.4.1.11 Input Port Change Registers UIPCRn

The UIPCR registers show the current state and the change-of-state for the $\overline{\text{CTS}}$ pin.

Table 15-20 Input Port Change Register (UIPCRn)

BITS	7	6	5	4	3	2	1	0
FIELD	RESVD	RESVD	RESVD	COS	RESVD	RESVD	RESVD	$\overline{\text{CTS}}$
RESET	0	0	0	0	1	1	1	\uparrow
R/W	READ ONLY							
ADDR	MBAR + \$1D0 MBAR + \$210							

Table 15-21 Input Port Change Bit Descriptions

BIT NAME	DESCRIPTION
Bits 7, 6, 5, 3, 2, 1	Reserved
COS	Change-of-State 1 = A change-of-state (high-to-low or low-to-high transition), lasting longer than 25–50 μs has occurred at the $\overline{\text{CTS}}$ input. When this bit is set, the UART Auxiliary Control Register (UACR) can be programmed to generate an interrupt to the CPU. 0 = No change-of-state has occurred since the last time the CPU read the UART Input Port Change Register (UIPCR). A read of the UIPCR also clears the UART Interrupt Status Register (UISR)COS bit.
$\overline{\text{CTS}}$	Current State Starting two serial clock periods after reset, the $\overline{\text{CTS}}$ bit reflects the state of the $\overline{\text{CTS}}$ pin. If the $\overline{\text{CTS}}$ pin is detected as asserted at that time, the COS bit is set, which initiates an interrupt if the Input Enable Control (IEC) bit of the UACR register is enabled. 1 = The current state of the $\overline{\text{CTS}}$ input is logic one. 0 = The current state of the $\overline{\text{CTS}}$ input is logic zero.

15.4.1.12 Auxiliary Control Registers (UACRn)

The UART auxiliary control registers control the input enable.

Table 15-22 Auxiliary Control Register (UACRn)

BITS	7	6	5	4	3	2	1	0
FIELD	-	-	-	-	-	-	-	IEC
RESET	0	0	0	0	0	0	0	0
R/W	WRITE ONLY							
ADDR	MBAR + \$1D0 (UACR0) MBAR + \$210 (UACR1)							

Table 15-23 Auxiliary Control Bit Descriptions

BIT NAME	DESCRIPTION
IEC	Input Enable Control 1 = UISR bit 7 is set and generates an interrupt when the COS bit in the UART Input Port Change Register (UIPCR) is set by an external transition on the \overline{CTS} input (if bit 7 of the interrupt mask register (UIMR) is set to enable interrupts). 0 = Setting the corresponding bit in the UIPCR has no effect on UISR bit 7.

15.4.1.13 Interrupt Status Registers (UISRn)

The UISR registers provides status for all potential interrupt sources. The UART Interrupt Mask Register (UIMR) masks the contents of this register. If a flag in the UISR is set and the corresponding bit in UIMR is also set, the internal interrupt output is asserted. If the corresponding bit in the UIMR is cleared, the state of the bit in the UISR has no effect on the interrupt output.

Note: The UIMR does not mask reading of the UISR. True status is provided regardless of the contents of UIMR. A UART module reset clears the contents of UISR.

Table 15-24 Interrupt Status Register (UISRn)

BITS	7	6	5	4	3	2	1	0
FIELD	COS	—	—	—	—	DB	RXRDY	TXRDY
RESET	0	0	0	0	0	0	0	0
R/W	READ ONLY							
ADDR	MBAR + \$1D4 (UISR0) MBAR + \$214 (UISR1)							

Table 15-25 Interrupt Status Bit Descriptions

BIT NAME	DESCRIPTION
COS	Change-of-State 1 = A change-of-state has occurred at the $\overline{\text{CTS}}$ input and has been selected to cause an interrupt by programming bit 0 of the UACR. 0 = COS bit in the UIPCR is not selected.
DB	Delta Break 1 = The receiver has detected the beginning or end of a received break. 0 = No new break-change condition to report. Refer to 15.4.1.5 Command Registers (UCRn) for more information on the reset break-change interrupt command.
RxDY	Receiver Ready or FIFO Full UMR1 bit 6 programs the function of this bit. It is a duplicate of either the FFULL or RxDY bit of USR.
TxRDY	Transmitter Ready This bit is the duplication of the TxRDY bit in USR. 1 = The transmitter holding register is empty and ready to be loaded with a character. 0 = The CPU loads the transmitter-holding register or the transmitter is disabled. Characters loaded into the transmitter-holding register when TxRDY=0 are not transmitted.

15.4.1.14 Interrupt Mask Registers (UIMRn)

The UIMR registers select the corresponding bits in the UISR that cause an interrupt. By setting the bit, the interrupt is enabled. If one of the bits in the UISR is set and the corresponding bit in the UIMR is also set, the internal interrupt output is asserted. If the corresponding bit in the UIMR is zero, the state of the bit in the UISR has no effect on the interrupt output. The UIMR does not mask the reading of the UISR.

Table 15-26 Interrupt Mask Register (UIMRn)

BITS	7	6	5	4	3	2	1	0
FIELD	COS	—	—	—	—	DB	FFULL	TxRDY
RESET	0	0	0	0	0	0	0	0
R/W	WRITE ONLY							
ADDR	MBAR + \$1D4 (UIMR0) MBAR + \$214 (UIMR1)							

Table 15-27 Interrupt Mask Bit Descriptions

BIT NAME	DESCRIPTION
COS	Change-of-State 1 = Enable interrupt 0 = Disable interrupt
DB	Delta Break 1 = Enable interrupt 0 = Disable interrupt
FFULL	FIFO Full 1 = Enable interrupt 0 = Disable interrupt
TxRDY	Transmitter Ready 1 = Enable interrupt 0 = Disable interrupt

15.4.1.15 Timer Upper Preload Register (UBG1n)

The UBG registers hold the eight most significant bits of the preload value the timer uses for providing a given baud rate. The minimum value that can be loaded on the concatenation of UBG1 with UBG2 is \$0002. This register is write only and cannot be read by the CPU. The UBG1 address is MBAR + \$1D8 for UART0 and MBAR + \$218 UART1.

15.4.1.16 Timer Upper Preload Register 2 (UBG2n)

The UBG2 register holds the eight least significant bits of the preload value the timer uses for providing a given baud rate. The minimum value that can be loaded on the concatenation of UBG1 with UBG2 is \$0002. This register is write only and cannot be read by the CPU. The UBG2 address is MBAR + \$1DC for UART0 and MBAR + \$21C UART1.

15.4.1.17 Interrupt Vector Registers (UIVRn)

The UIVR registers contain the 8-bit vector number of the internal interrupt.

Table 15-28 Interrupt Vector Register (UIVRn)

BITS	7	6	5	4	3	2	1	0
FIELD	IVR7	IVR6	IVR5	IVR4	IVR3	IVR2	IVR1	IVR0
RESET	0	0	0	0	1	1	1	1
R/W	SUPERVISOR OR USER							
ADDR	MBAR + \$1F0 (UIVR0) MBAR + \$230 (UIVR1)							

Table 15-29 Interrupt Vector Bit Descriptions

BIT NAME	DESCRIPTION
IVR7–IVR0	The Interrupt Vector Bits are an 8-bit number that indicates the offset from the base of the vector table where the address of the exception handler for the specified interrupt is located. The UIVR is reset to \$0F, which indicates an uninitialized interrupt condition.

15.4.1.18 Input Port Registers (UIPn)

The UIP registers show the current state of the $\overline{\text{CTS}}$ input.

Table 15-30 Input Port Register (UIPn)

BITS	7	6	5	4	3	2	1	0
FIELD	—	—	—	—	—	—	—	$\overline{\text{CTS}}$
RESET	1	1	1	1	1	1	1	1
R/W	READ ONLY							
ADDR	MBAR + \$1F4 (UIP0) MBAR + \$234 (UIP1)							

Table 15-31 Interrupt Vector Bit Descriptions

BIT NAME	DESCRIPTION
$\overline{\text{CTS}}$	<p>Current State</p> <p>1 = The current state of the $\overline{\text{CTS}}$ input is logic one. 0 = The current state of the $\overline{\text{CTS}}$ input is logic zero. The information contained in this bit is latched and reflects the state of the input pin at the time that the UIP is read. This bit has the same function and value as the UIPCR bit 0.</p>

15.4.1.19 Output Port Data Registers (UOP1n)

The $\overline{\text{RTS}}$ output is set by a bit set command (writing to UOP1) and is cleared by a bit reset command (writing to UOP0).

Table 15-32 Output Port Data Registers (UOP1n)

BITS	7	6	5	4	3	2	1	0
FIELD								RTS
RESET	—	—	—	—	—	—	—	0
R/W	WRITE ONLY							
ADDR	MBAR + \$1F8 (UOP10) MBAR + \$238 (UOP11)							

Table 15-33 Output Port Data Bit Descriptions

BIT NAME	DESCRIPTION
RTS	Output Port Parallel Output 1 = A write cycle to the OPset address asserts the $\overline{\text{RTS}}$ signal. 0 = This bit is not affected by writing a zero to this address. The output port bits are inverted at the pins so the $\overline{\text{RTS}}$ set bit provides an asserted $\overline{\text{RTS}}$ pin.

Table 15-34 Output Port Data Registers (UOP0n)

BITS	7	6	5	4	3	2	1	0
FIELD	—	—	—	—	—	—	—	RTS
RESET	—	—	—	—	—	—	—	—
R/W	WRITE ONLY							
ADDR	MBAR + \$1FC (UOP00) MBAR + \$23C (UOP01)							

15.4.2 PROGRAMMING

Figure 11-9 shows the basic interface software flowchart required for operation of the UART module. The routines are divided into these three categories:

1. UART Module Initialization
2. I/O Driver
3. Interrupt Handling

15.4.2.1 UART Module Initialization

The UART module initialization routines consist of SINIT and CHCHK. SINIT is called at system initialization time to check UART operation. Before SINIT is called, the calling routine allocates two words on the system stack. On return to the calling routine, SINIT passes information on the system stack to reflect the status of the UART. If SINIT finds no errors, the receiver and transmitter are enabled. The CHCHK routine performs the actual checks as called from the SINIT routine. When called, SINIT places the UART in the local loopback mode and checks for the following errors:

- Transmitter Never Ready
- Receiver Never Ready
- Parity Error
- Incorrect Character Received

15.4.2.2 I/O Driver Example

The I/O driver routines consist of INCH and OUTCH. INCH is the terminal input character routine and obtains a character from the receiver. OUTCH sends a character to the transmitter.

15.4.2.3 Interrupt Handling

The interrupt-handling routine consists of SIRQ, which is executed after the UART module generates an interrupt caused by a change in break (beginning of a break). SIRQ then clears the interrupt source, waits

for the next change-in-break interrupt (end of break), clears the interrupt source again, then returns from exception processing to the system monitor.

15.5 UART MODULE INITIALIZATION SEQUENCE

The following steps are required to properly initialize the UART module:

Command Register (UCR)

1. Reset the receiver and transmitter.
2. Program the vector number for a UART module interrupt.

Interrupt Mask Register (UIMR)

1. Enable the desired interrupt sources.

Auxiliary Control Register (UACR)

1. Initialize the Input Enable Control (IEC) bit.
2. Select timer mode and clock source, if necessary.

Clock Select Register (UCSR)

1. Select the receiver and transmitter clock. Use timer as source, if required.

Mode Register 1 (UMR1)

1. If required, program operation of Receiver Ready-to-Send (RxRTS Bit).
2. Select Receiver-Ready or FIFO-Full Notification (R/F Bit).
3. Select character or block-error mode (ERR Bit).
4. Select parity mode and type (PM and PT Bits).
5. Select number of bits per character (B/Cx Bits).

Mode Register 2 (UMR2)

1. Select the mode of operation (CMx bits).
2. If required, program operation of Transmitter Ready-to-Send (TxRTS Bit).
3. If required, program operation of Clear-to-Send (TxCTS Bit).
4. Select stop-bit length (SBx Bits).

Command Register (UCR)

1. Enable the receiver and transmitter.

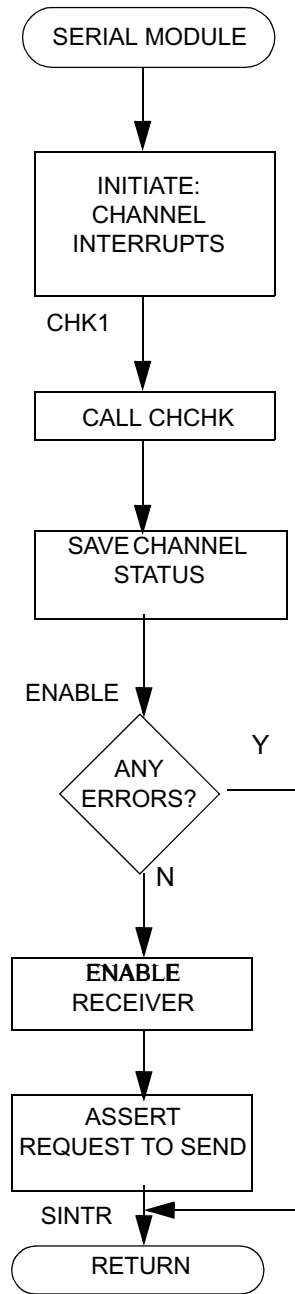

Figure 15-9 UART Software Flowchart (1 of 5)

Freescale Semiconductor, Inc.
UART Module Initialization Sequence

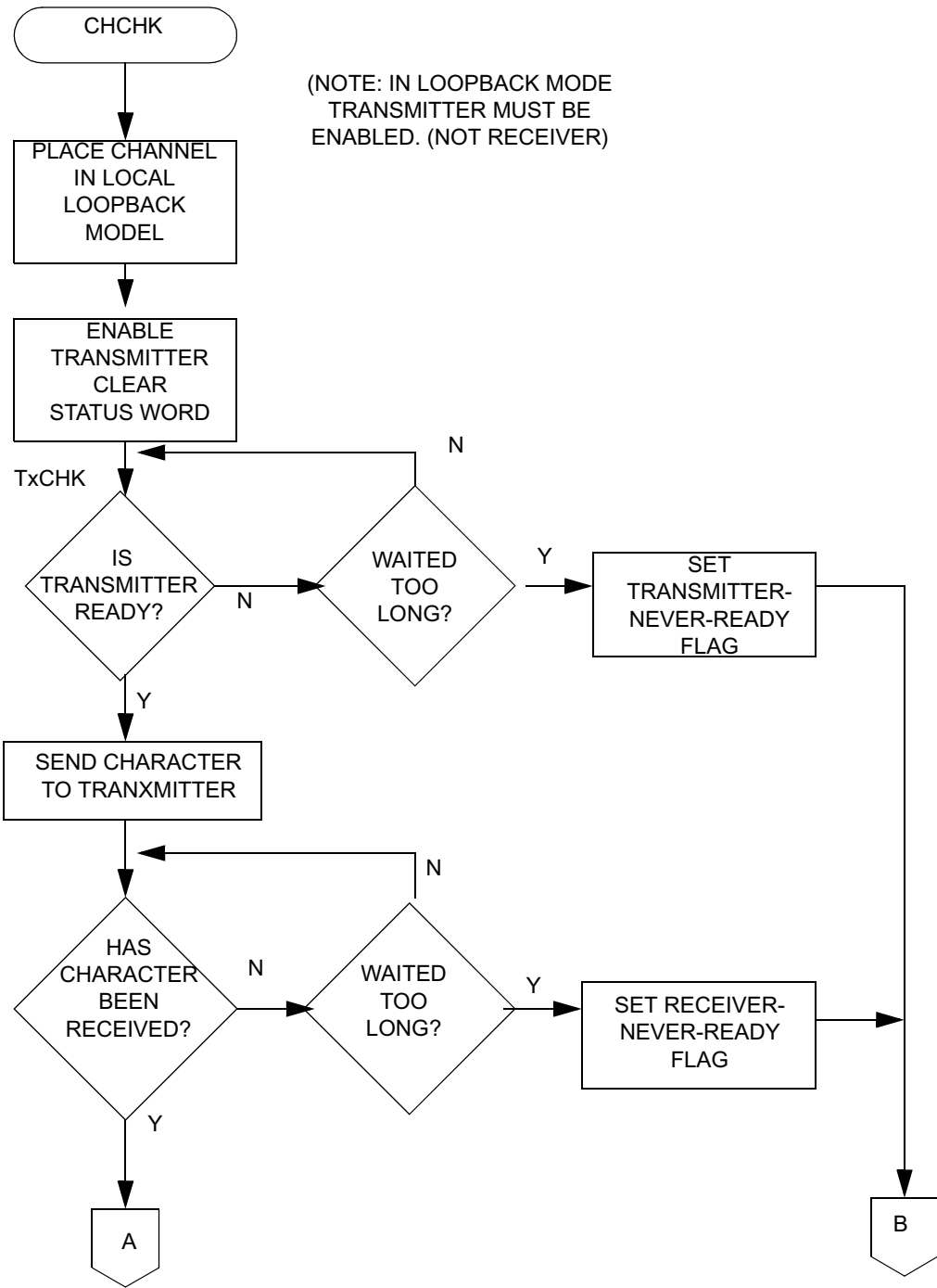

Figure 15-10 UART Software Flowchart (2 of 5)

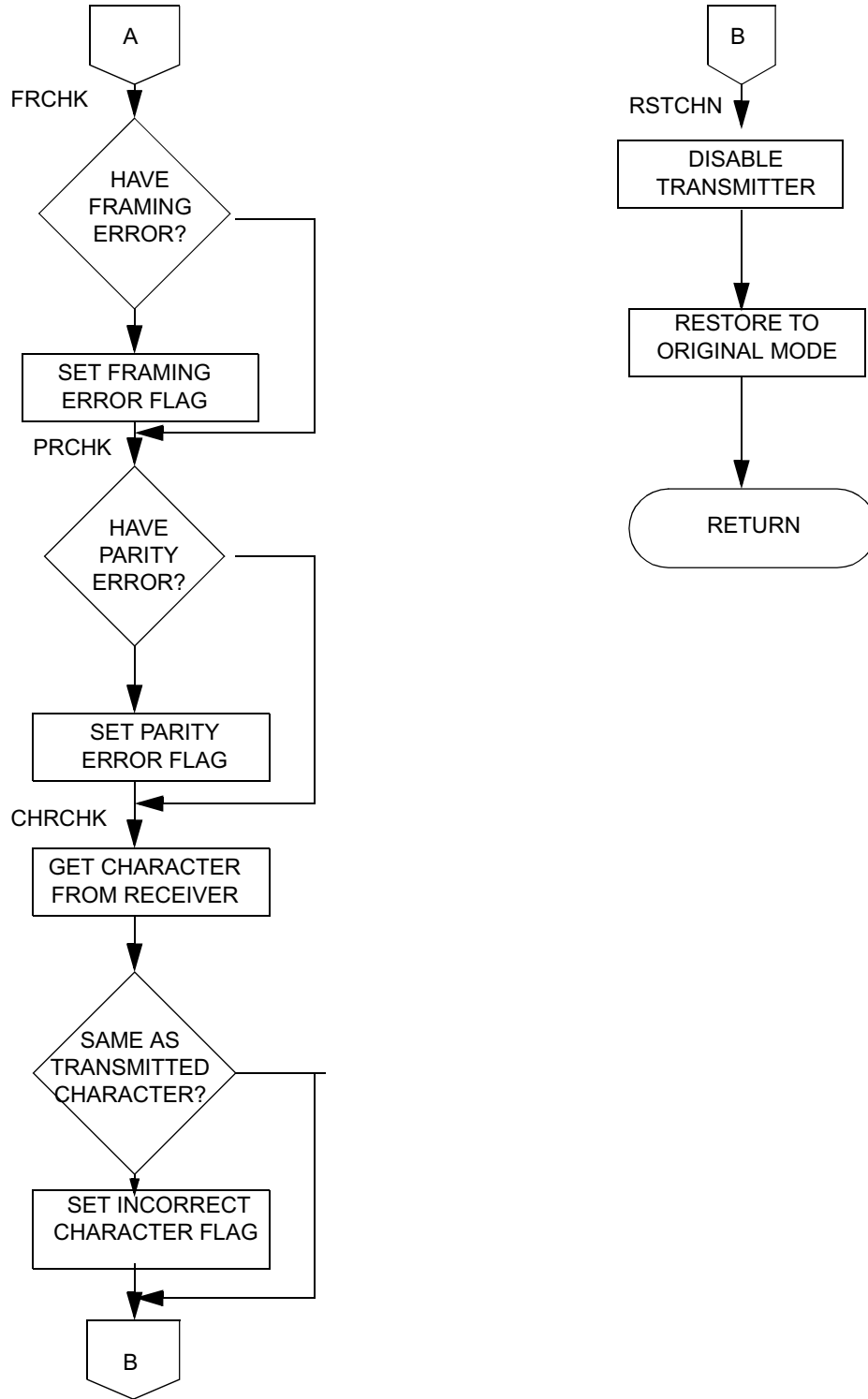

Figure 15-11 UART Software Flowchart (3 of 5)

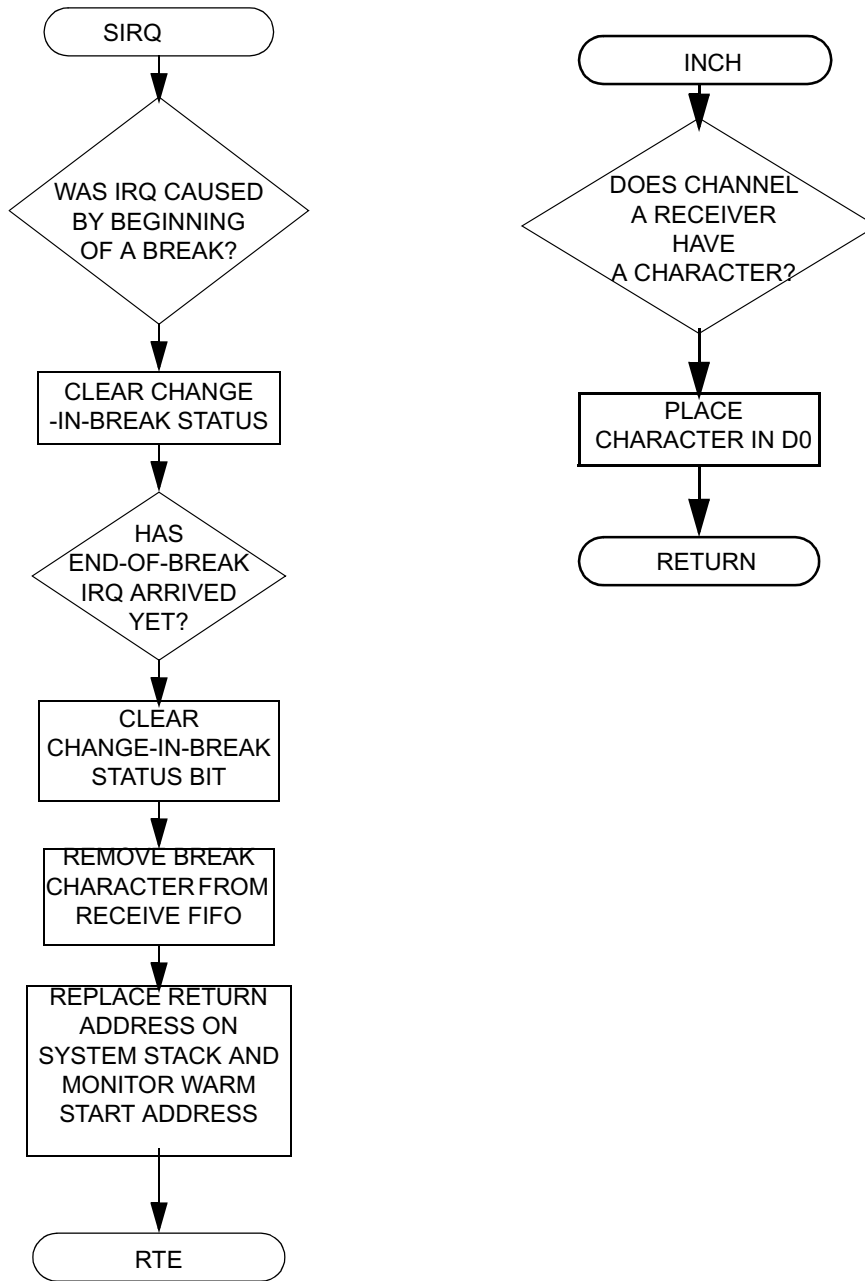

Figure 15-12 UART Software Flowchart (4 of 5)

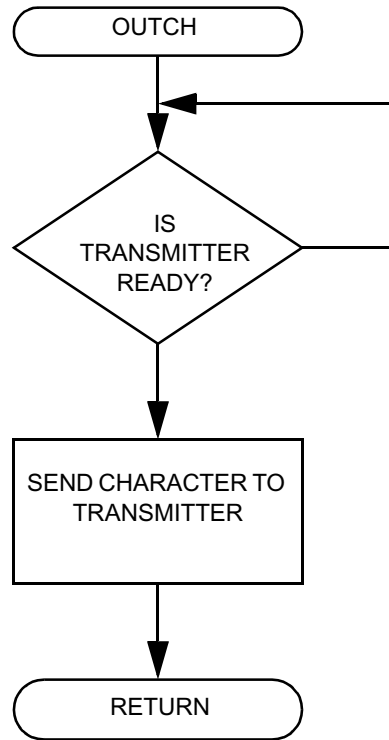

Figure 15-13 UART Software Flowchart (5 of 5)

NOTES

Section 16

Queued Serial Peripheral Interface (QSPI) Module

This section describes the queued serial peripheral interface (QSPI) module. Following a feature-set overview is a description of operation including details of the QSPI's internal RAM organization. The section concludes with the programming model and a timing diagram.

16.1 OVERVIEW

The queued serial peripheral interface module provides a serial peripheral interface with queued transfer capability. It allows users to queue up to 16 transfers at once, eliminating CPU intervention between transfers. Transfer RAMs in the QSPI are indirectly accessible using address and data registers. The QSPI is functionally similar to the QSM in the 68332.

16.2 FEATURES

- Programmable queue to support up to 16 transfers without user intervention
- Supports transfer sizes of 8 to 16 bits in 1-bit increments
- Four peripheral chip-select lines for control of up to 15 devices
- Baud rates from 134 Kbps to 16.7 Mbps at a CPU clock of 140 MHz
- Programmable delays before and after transfers
- Programmable clock phase and polarity
- Supports wraparound mode for continuous transfers

16.3 MODULE DESCRIPTION

The QSPI module communicates with the integrated ColdFire CPU using internal memory mapped registers located starting at MBAR + \$400. See also [Section 16.5 Programming Model](#). A block diagram of the QSPI module is shown in [Figure 16-1](#).

16.3.1 INTERFACE AND PINS

The module provides as many as 15 ports and a total of seven signals: QSPI_Dout, QSPI_Din, QSPI_CLK, QSPI_CS [3:0].

Peripheral chip-select signals, QSPI_CS[3:0], are used to select an external device as the source or destination for serial data transfer. Signals are asserted at a logic level corresponding to the value of the QSPI_CS[3:0] bits in the command RAM whenever a command in the queue is executed. More than one chip-select signal can be asserted simultaneously.

Although QSPI_CS[3:0] will function as simple chip selects in most applications, up to 15 ports can be selected by decoding them with an external 4-to-16 decoder.

Module Description

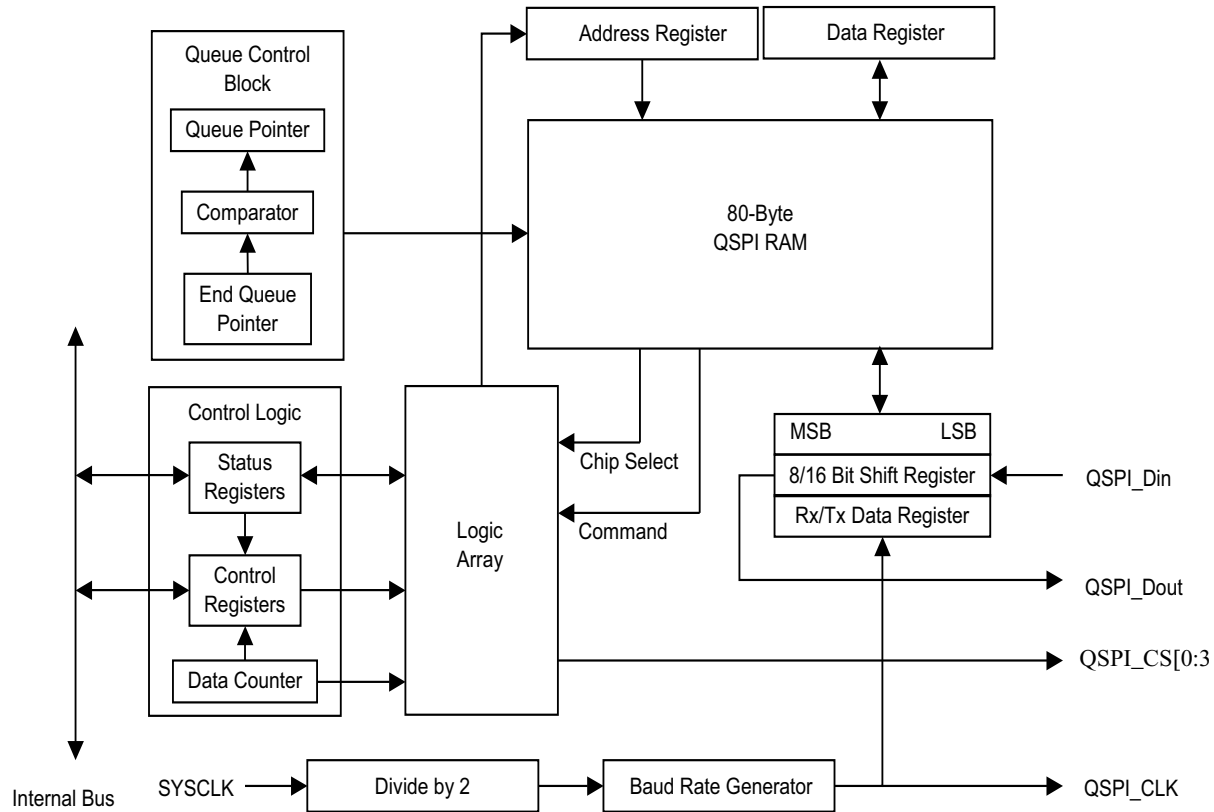

Figure 16-1 QSPI Block Diagram

Note: QSPI_CLK and QSPI_DIN are muxed with SCL2 and SDA2 (second I²C interface). The QSPI function must be selected by setting the QSPISEL bit in the PLLCR register.

Table 16-1 QSPI Input and Output Signals and Functions

SIGNAL NAME	HI-Z OR ACTIVELY DRIVEN	FUNCTION
QSPI Data Output (QSPI_Dout)	Configurable	Serial data output from QSPI
QSPI Data Input (QSPI_Din)	N/A	Serial data input to QSPI
Serial Clock (QSPI_CLK)	Actively driven	Clock output from QSPI
Peripheral Chip Selects (QSPI_CS[3:0])	Actively driven	Peripheral selects
Select the QSPI function using the PLLCR register.		

16.3.2 INTERNAL BUS INTERFACE

Because the QSPI module only operates in master mode, the master bit in the QSPI mode register (QMR[MSTR]) must be set for the QSPI to function properly. The QSPI can initiate serial transfers but cannot respond to transfers initiated by other QSPI masters.

16.4 OPERATION

The QSPI uses a dedicated 80-byte block of static RAM accessible both to the module and the CPU to perform queued operations. The RAM is divided into three segments as follows:

- 16 command control bytes (command RAM)
- 16 transmit data words (transfer RAM)
- 16 receive data words (transfer RAM)

RAM is organized so that 1 byte of command control data, 1 word of transmit data, and 1 word of receive data comprise 1 queue entry, 0x0–0xF.

The user initiates QSPI operation by loading a queue of commands in command RAM, writing transmit data into transmit RAM, and then enabling the QSPI data transfer. The QSPI executes the queued commands and sets the completion flag in the QSPI interrupt register (QIR[SPIF]) to signal their completion. Optionally, QIR[SPIFE] can be enabled to generate an interrupt.

The QSPI uses four queue pointers. The user can access three of them through fields in QSPI wrap register (QWR):

- The new queue pointer, QWR[NEWQP], points to the first command in the queue.
- An internal queue pointer points to the command currently being executed.
- The completed queue pointer, QWR[CPTQP], points to the last command executed.
- The end queue pointer, QWR[ENDQP], points to the final command in the queue.

The internal pointer is initialized to the same value as QWR[NEWQP]. During normal operation, the following sequence repeats:

1. The command pointed to by the internal pointer is executed.
2. The value in the internal pointer is copied into QWR[CPTQP].
3. The internal pointer is incremented.

Execution continues at the internal pointer address unless the QWR[NEWQP] value is changed. After each command is executed, QWR[ENDQP] and QWR[CPTQP] are compared. When a match occurs, QIR[SPIF] is set and the QSPI stops unless wraparound mode is enabled. Setting QWR[WREN] enables wraparound mode.

QWR[NEWQP] is cleared at reset. When the QSPI is enabled, execution begins at address 0x0 unless another value has been written into QWR[NEWQP]. QWR[ENDQP] is cleared at reset but is changed to show the last queue entry before the QSPI is enabled. QWR[NEWQP] and QWR[ENDQP] can be written at any time. When the QWR[NEWQP] value changes, the internal pointer value also changes unless a transfer is in progress, in which case the transfer completes normally. Leaving QWR[NEWQP] and QWR[ENDQP] set to 0x0 causes a single transfer to occur when the QSPI is enabled.

Data is transferred relative to QSPI_CLK which can be generated in any one of four combinations of phase and polarity using QMR[CPHA, CPOL]. Data is transferred most significant bit (msb) first. The number of bits transferred defaults to eight, but can be set to any value from 8 to 16 by writing a value into the BITSE field of the command RAM, QCR[BITSE].

16.4.1 QSPI RAM

The QSPI contains an 80-byte block of static RAM that can be accessed by both the user and the QSPI. This RAM does not appear in the MCF5249 memory map because it can only be accessed by the user

Operation

indirectly through the QSPI address register (QAR) and the QSPI data register (QDR). The RAM is divided into three segments with 16 addresses each:

- Receive data RAM, the initial destination for all incoming data
- Transmit data RAM, a buffer for all out-bound data
- Command RAM, where commands are loaded

The transmit and command RAM are write-only by the user. The receive RAM is read-only by the user. [Figure 16-2](#) shows the RAM configuration. The RAM contents are undefined immediately after a reset.

The command and data RAM in the QSPI is indirectly accessible with QDR and QAR as 48 separate locations that comprise 16 words of transmit data, 16 words of receive data and 16 bytes of commands.

A write to QDR causes data to be written to the RAM entry specified by QAR[ADDR] and causes the value in QAR to increment. Correspondingly, a read at QDR returns the data in the RAM at the address specified by QAR[ADDR]. This also causes QAR to increment. A read access requires a single wait state.

RELATIVE ADDRESS	REGISTER	FUNCTION
0x00	QTR0	Transmit RAM 16 bits wide
0x01	QTR1	
.	.	
.	.	
0x0F	QTR15	
0x10	QRR0	Receive RAM 16 bits wide
0x11	QRR1	
.	.	
.	.	
0x1F	QRR15	
0x20	QCR0	Command RAM 8 bits wide
0x21	QCR1	
.	.	
.	.	
0x2F	QCR15	

Figure 16-2 QSPI RAM Model

16.4.1.1 Transmit RAM

Data to be transmitted by the QSPI is stored in the transmit RAM segment located at addresses 0x0 to 0xF. The user normally writes 1 word into this segment for each queue command to be executed. The user cannot read transmit RAM.

Out-bound data must be written to transmit RAM in a right-justified format. The unused bits are ignored. The QSPI copies the data to its data serializer (shift register) for transmission. The data is transmitted most significant bit first and remains in transmit RAM until overwritten by the user.

16.4.1.2 Receive RAM

Data received by the QSPI is stored in the receive RAM segment located at 0x10 to 0x1F in the QSPI RAM space. The user reads this segment to retrieve data from the QSPI. Data words with less than 16 bits are stored in the least significant bits of the RAM. Unused bits in a receive queue entry are set to zero upon completion of the individual queue entry.

Note: Throughout ColdFire documentation, 'word' is used consistently and exclusively to designate a 16-bit data unit. The only exceptions to this rule appear in the sections that detail serial communication modules such as the QSPI that supports variable-length data units. To simplify this issue, the functional unit is referred to as a 'word' regardless of length.

QWR[CPTQP] shows which queue entries have been executed. The user can query this field to determine which locations in receive RAM contain valid data.

16.4.1.3 Command RAM

The CPU writes one byte of control information to this segment for each QSPI command to be executed. Command RAM is write-only memory from a user's perspective.

Command RAM consists of 16 bytes with each byte divided into two fields. The peripheral chip select field controls the QSPI_CS signal levels for the transfer. The command control field provides transfer options.

A maximum of 16 commands can be in the queue. Queue execution proceeds from the address in QWR[NEWQP] through the address in QWR[ENDQP].

The QSPI executes a queue of commands defined by the control bits in each command RAM entry which sequence the following actions:

- chip-select pins are activated
- data is transmitted from transmit RAM and received into the receive RAM
- the synchronous transfer clock QSPI_CLK is generated

Before any data transfers begin, control data must be written to the command RAM, and any out-bound data must be written to transmit RAM. Also, the queue pointers must be initialized to the first and last entries in the command queue.

Data transfer is synchronized with the internally generated QSPI_CLK, whose phase and polarity are controlled by QMR[CPHA] and QMR[CPOL]. These control bits determine which QSPI_CLK edge is used to drive outgoing data and to latch incoming data.

16.4.2 BAUD RATE SELECTION

Baud rate is selected by writing a value from 2–255 into QMR[BAUD]. The QSPI uses a prescaler to derive the QSPI_CLK rate from the system clock, SYSCLK, divided by two.

A baud rate value of zero turns off the QSPI_CLK.

The desired QSPI_CLK baud rate is related to SYSCLK and QMR[BAUD] by the following expression:

$$\text{QMR[BAUD]} = \text{SYSCLK} / [2 \times (\text{desired QSPI_CLK baud rate})]$$

Table 16-2 QSPI_CLK Frequency as Function of CPU Clock and Baud Rate

QMR [BAUD]	CPU Clock			
	66 MHz	48 MHz	33 MHz	20 MHz
2	16,500,000	12,000,000	8,250,000	5,000,000
4	8,250,000	6,000,000	4,125,000	2,500,000
8	4,125,000	3,000,000	2,062,500	1,250,000
16	2,062,500	1,500,000	1,031,250	625,000
32	1,031,250	750,000	515,625	312,500
255	129,412	94,118	64,706	39,216

16.4.3 TRANSFER DELAYS

The QSPI supports programmable delays for the QSPI_CS signals before and after a transfer. The time between QSPI_CS assertion and the leading QSPI_CLK edge, and the time between the end of one transfer and the beginning of the next, are both independently programmable.

The chip select to clock delay enable (DSCK) bit in command RAM, QCR[DSCK], enables the programmable delay period from QSPI_CS assertion until the leading edge of QSPI_CLK. QDLR[QCD] determines the period of delay before the leading edge of QSPI_CLK. The following expression determines the actual delay before the QSPI_CLK leading edge:

$$\text{QSPI_CS-to-QSPI_CLK delay} = \text{QCD}/\text{SYSCLK frequency}$$

QCD has a range of 1–127.

When QCD or DSCK equals zero, the standard delay of one-half the QSPI_CLK period is used.

The delay after transmit enable (DT) bit in command RAM enables the programmable delay period from the negation of the QSPI_CS signals until the start of the next transfer. The delay after transfer can be used to provide a peripheral deselect interval. A delay can also be inserted between consecutive transfers to allow serial A/D converters to complete conversion. There are two transfer delay options: the user can choose to delay a standard period after serial transfer is complete or can specify a delay period. Writing a value to QDLR[DTL] specifies a delay period. The DT bit in command RAM determines whether the standard delay period (DT = 0) or the specified delay period (DT = 1) is used. The following expression is used to calculate the delay:

$$\text{Delay after transfer} = 32 \times \text{QDLR[DTL]} / \text{SYSCLK frequency} \quad (\text{DT} = 1)$$

where QDLR[DTL] has a range of 2–255.

A zero value for DTL causes a delay-after-transfer value of 8192/SYSCLK frequency.

$$\text{Standard delay after transfer} = 17/\text{SYSCLK frequency} \quad (\text{DT} = 0)$$

Adequate delay between transfers must be specified for long data streams because the QSPI module requires time to load a transmit RAM entry for transfer. Receiving devices need at least the standard delay between successive transfers. If SYSCLK is operating at a slower rate, the delay between transfers must be increased proportionately.

16.4.4 TRANSFER LENGTH

There are two transfer length options. The user can choose a default value of 8 bits or a programmed value of 8 to 16 bits inclusive. The programmed value must be written into QMR[BITS]. The bits per transfer enable (BITSE) field in the command RAM determines whether the default value (BITSE = 0) or the BITS[3–0] value (BITSE = 1) is used. QMR[BITS] gives the required number of bits to be transferred, with 0b0000 representing 16.

16.4.5 DATA TRANSFER

Operation is initiated by setting QDLYR[SPE]. Shortly after QDLYR[SPE] is set, the QSPI executes the command at the command RAM address pointed to by QWR[NEWQP]. Data at the pointer address in transmit RAM is loaded into the data serializer and transmitted. Data that is simultaneously received is stored at the pointer address in receive RAM.

When the proper number of bits has been transferred, the QSPI stores the working queue pointer value in QWR[CPTQP], increments the working queue pointer, and loads the next data for transfer from the transmit RAM. The command pointed to by the incremented working queue pointer is executed next unless a new value has been written to QWR[NEWQP]. If a new queue pointer value is written while a transfer is in progress, then that transfer is completed normally.

When the CONT bit in the command RAM is set, the QSPI_CS signals are asserted between transfers. When CONT is cleared, QSPI_CS[3:0] are negated between transfers. The QSPI_CS signals are not high impedance.

When the QSPI reaches the end of the queue, it asserts the SPIF flag, QIR[SPIF]. If QIR[SPIFE] is set, an interrupt request is generated when QIR[SPIF] is asserted. Then the QSPI clears QDLYR[SPE] and stops, unless wraparound mode is enabled.

Wraparound mode is enabled by setting QWR[WREN]. The queue can wrap to pointer address 0x0, or to the address specified by QWR[NEWQP], depending on the state of QWR[WRTO].

In wraparound mode, the QSPI cycles through the queue continuously, even while requesting interrupt service. QDLYR[SPE] is not cleared when the last command in the queue is executed. New receive data overwrites previously received data in the receive RAM. Each time the end of the queue is reached, QIR[SPIFE] is set. QIR[SPIF] is not automatically reset. If interrupt driven QSPI service is used, the service routine must clear QIR[SPIF] to abort the current request. Additional interrupt requests during servicing can be prevented by clearing QIR[SPIFE].

There are two recommended methods of exiting wraparound mode: clearing QWR[WREN] or setting QWR[HALT]. Exiting wraparound mode by clearing QDLYR[SPE] is not recommended because this may abort a serial transfer in progress. The QSPI sets SPIF, clears QDLYR[SPE], and stops the first time it reaches the end of the queue after QWR[WREN] is cleared. After QWR[HALT] is set, the QSPI finishes the current transfer, then stops executing commands. After the QSPI stops, QDLYR[SPE] can be cleared.

16.5 PROGRAMMING MODEL

The programming model for the QSPI consists of six registers. They are the QSPI mode register (QMR), QSPI delay register (QDLYR), QSPI wrap register (QWR), QSPI interrupt register (QIR), QSPI address register (QAR), and the QSPI data register (QDR).

There are a total of 80 bytes of memory used for transmit, receive, and control data. This memory is accessed indirectly using QAR and QDR.

Registers and RAM are written and read by the CPU.

16.5.1 QSPI MODE REGISTER (QMR)

The QMR register, shown in [Figure 16-3](#), determines the basic operating modes of the QSPI module. Parameters such as clock polarity and phase, baud rate, master mode operation, and transfer size are determined by this register. The data output high impedance enable, DOHIE, controls the operation of QSPI_Dout between data transfers. When DOHIE is cleared, QSPI_Dout is actively driven between transfers. When DOHIE is set, QSPI_Dout assumes a high impedance state.

Note: Because the QSPI does not operate in slave mode, the master mode enable bit, QMR[MSTR], must be set for the QSPI module to operate correctly.

	15	14	13	10	9	8	7	0
Field	MSTR	DOHIE	BITS		CPO L	CPHA	BAUD	
Reset	0000_0001_0000_0100							
R/W	R/W							
Addresses	MBAR + 0 x 400							

Figure 16-3 QSPI Mode Register (QSPIMR)

Note: All QSPI registers must be accessed as 16-bits only.

[Table 16-3](#) gives QMR field descriptions.

Table 16-3 QSPIMR Field Descriptions

BITS	NAME	DESCRIPTION
15	MSTR	Master mode enable. 0 Reserved, do not use. 1 The QSPI is in master mode. Must be set for the QSPI module to operate correctly.
14	DOHIE	Data output high impedance enable. Selects QSPI_Dout mode of operation. 0 Default value after reset. QSPI_Dout is actively driven between transfers. 1 QSPI_Dout is high impedance between transfers.

Table 16-3 QSPIMR Field Descriptions (Continued)

BITS	NAME	DESCRIPTION
13–10	BITS	Transfer size. Determines the number of bits to be transferred for each entry in the queue. ValueBits per transfer 000016 0001– 0111 Reserved 1000 8 1001 9 101010 101111 110012 110113 111014 111115
9	CPOL	Clock polarity. Defines the clock polarity of QSPI_CLK. 0 The inactive state value of QSPI_CLK is logic level 0. 1 The inactive state value of QSPI_CLK is logic level 1.
8	CPHA	Clock phase. Defines the QSPI_CLK clock-phase. 0 Data captured on the leading edge of QSPI_CLK and changed on the following edge of QSPI_CLK. 1 Data changed on the leading edge of QSPI_CLK and captured on the following edge of QSPI_CLK.
7–0	BAUD	Baud rate divider. The baud rate is selected by writing a value in the range 2–255. A value of zero disables the QSPI. The desired QSPI_CLK baud rate is related to SYSCLK and QMR[BAUD] by the following expression: $QMR[BAUD] = \text{SystemClock} / [2 \times (\text{desired QSPI_CLK baud rate})]$

Figure 16-4 shows an example of a QSPI clocking and data transfer.

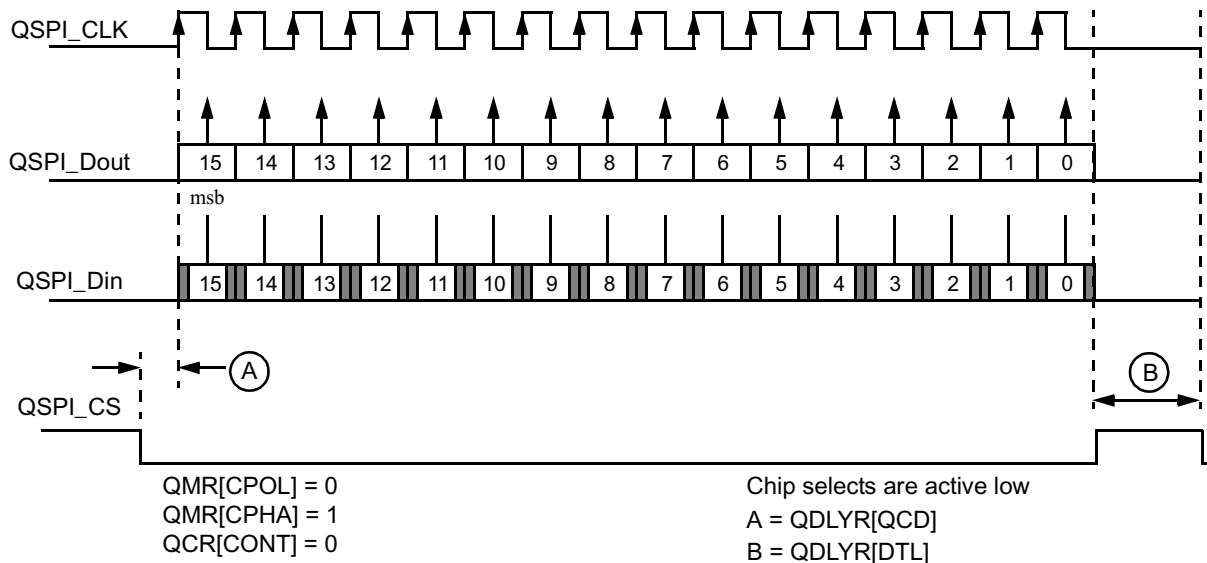

Figure 16-4 QSPI Clocking and Data Transfer Example

16.5.2 QSPI DELAY REGISTER (QDLYR)

Figure 16-5 shows the QSPI delay register.

	15	14		8	7		0	
Field	SPE		QCD			DTL		
Reset	0000_0100_0000_0100							
R/W	R/W							
Address	MBAR + 0x404							

Figure 16-5 QSPI Delay Register (QDLYR)

Note: All QSPI registers must be accessed as 16-bits only.

Table 16-4 gives QDLYR field descriptions.

Table 16-4 QDLYR Field Descriptions

BITS	NAME	DESCRIPTION
15	SPE	QSPI enable. When set, the QSPI initiates transfers in master mode by executing commands in the command RAM. Automatically cleared by the QSPI when a transfer completes. The user can also clear this bit to abort transfer unless QIR[ABRTL] is set. The recommended method for aborting transfers is to set QWR[HALT].
14–8	QCD	QSPILCK Delay. When the DSCK bit in the command RAM, is set this field determines the length of the delay from assertion of the chip selects to valid QSPI_CLK transition.
7–0	DTL	Delay after transfer. When the DT bit in the command RAM sets this field, it determines the length of delay after the serial transfer.

16.5.3 QSPI WRAP REGISTER (QWR)

	15	14	13	12	11		8	7		4	3		0
Field	HALT	WREN	WRTO	CSIV	ENDQP			–		NEWQP			
Reset	0000_0000_0000_0000												
R/W	R/W												
Address	MBAR + 0 x 408												

Figure 16-6 QSPI Wrap Register (QWR)

Note: All QSPI registers must be accessed as 16-bits only.

Table 16-5 gives QWR field descriptions.

Table 16-5 QWR Field Descriptions

BITS	NAME	DESCRIPTION
15	HALT	Halt transfers. Assertion of this bit causes the QSPI to stop execution of commands once it has completed execution of the current command.
14	WREN	Wraparound enable. Enables wraparound mode. 0 Execution stops after executing the command pointed to by QWR[ENDQP]. 1 After executing command pointed to by QWR[ENDQP], wrap back to entry zero, or the entry pointed to by QWR[NEWQP] and continue execution.
13	WRTO	Wraparound location. Determines where the QSPI wraps to in wraparound mode. 0 Wrap to RAM entry zero. 1 Wrap to RAM entry pointed to by QWR[NEWQP].
12	CSIV	QSPI_CS inactive level. 0 QSPI chip select outputs return to zero when not driven from the value in the current command RAM entry during a transfer (that is, inactive state is 0, chip selects are active high). 1 QSPI chip select outputs return to one when not driven from the value in the current command RAM entry during a transfer (that is, inactive state is 1, chip selects are active low).
11–8	ENDQP	End of queue pointer. Points to the RAM entry that contains the last transfer description in the queue.
7–4	CPTQP	Completed queue entry pointer. Points to the RAM entry that contains the last command to have been completed. This field is read only.
3–0	NEWQP	Start of queue pointer. This 4-bit field points to the first entry in the RAM to be executed on initiating a transfer.

16.5.4 QSPI INTERRUPT REGISTER (QIR)

Figure 16-7 shows the QSPI interrupt register.

	15	14	13	12	11	10	9	8	7	4	3	2	1	0
Field	WCEFB	ABRTB	—	ABRTL	WCEFE	ABRTE	—	SPIFE	—	WCEF	ABRT	—	SPIF	
Reset	0000_0000_0000_0000													
R/W	R/W													
Addresses	MBAR + 0 x 40C													

Figure 16-7 QSPI Interrupt Register (QIR)

Note: All QSPI registers must be accessed as 16-bits only.

Table 16-6 describes QIR fields.

Freescale Semiconductor, Inc.

Table 16-6 QIR Field Descriptions

BITS	NAME	DESCRIPTION
15	WCEFB	Write collision access error enable. A write collision occurs during a data transfer when the RAM entry containing the command currently being executed is written to by the CPU with the QDR. When this bit is asserted, the write access to QDR results in an access error.
14	ABRTB	Abort access error enable. An abort occurs when QDLYR[SPE] is cleared during a transfer. When set, an attempt to clear QDLYR[SPE] during a transfer results in an access error.
13	—	Reserved, should be cleared.
12	ABRTL	Abort lock-out. When set, QDLYR[SPE] cannot be cleared by writing to the QDLYR. QDLYR[SPE] is only cleared by the QSPI when a transfer completes.
11	WCEFE	Write collision interrupt enable. Interrupt enable for WCEF. Setting this bit enables the interrupt, and clearing it disables the interrupt.
10	ABRTE	Abort interrupt enable. Interrupt enable for ABRT flag. Setting this bit enables the interrupt, and clearing it disables the interrupt.
9	—	Reserved, should be cleared.
8	SPIFE	QSPI finished interrupt enable. Interrupt enable for SPIF. Setting this bit enables the interrupt, and clearing it disables the interrupt.
7-4	—	Reserved, should be cleared.
3	WCEF	Write collision error flag. Indicates that an attempt has been made to write to the RAM entry that is currently being executed. Writing a 1 to this bit clears it and writing 0 has no effect.
2	ABRT	Abort flag. Indicates that QDLYR[SPE] has been cleared by the user writing to the QDLYR rather than by completion of the command queue by the QSPI. Writing a 1 to this bit clears it and writing 0 has no effect.
1	—	Reserved, should be cleared.
0	SPIF	QSPI finished flag. Asserted when the QSPI has completed all the commands in the queue. Set on completion of the command pointed to by QWR[ENDQP], and on completion of the current command after assertion of QWR[HALT]. In wraparound mode, this bit is set every time the command pointed to by QWR[ENDQP] is completed. Writing a 1 to this bit clears it and writing 0 has no effect.

The command and data RAM in the QSPI is indirectly accessible with QDR and QAR as 48 separate locations that comprise 16 words of transmit data, 16 words of receive data and 16 bytes of commands.

A write to QDR causes data to be written to the RAM entry specified by QAR[ADDR]. This also causes the value in QAR to increment.

Correspondingly, a read at QDR returns the data in the RAM at the address specified by QAR[ADDR]. This also causes QAR to increment. A read access requires a single wait state.

Note: The QAR does not wrap after the last queue entry within each section of the RAM.

16.5.5 QSPI ADDRESS REGISTER (QAR)

The QAR, shown in [Figure 16-8](#), is used to specify the location in the QSPI RAM that read and write operations affect.

	15	6	5	0
Field	—			ADDR
Reset	0000_0000_0000_0000			
R/W	R/W			
Address	MBAR + 0 x 410			

Figure 16-8 QSPI Address Register (QAR)

Note: All QSPI registers must be accessed as 16-bits only.

16.5.6 QSPI DATA REGISTER (QDR)

The QDR, shown in [Figure 16-9](#), is used to access QSPI RAM indirectly. The CPU reads and writes all data from and to the QSPI RAM through this register.

	15	0
Field	DATA	
Reset	0000_0000_0000_0000	
R/W	R/W	
Address	MBAR + 0 x 414	

Figure 16-9 QSPI Data Register (QDR)

Note: All QSPI registers must be accessed as 16-bits only.

16.5.7 COMMAND RAM REGISTERS (QCR0–QCR15)

The command RAM is accessed using the upper byte of QDR. The QSPI cannot modify information in command RAM.

There are 16 bytes in the command RAM. Each byte is divided into two fields. The chip select field enables external peripherals for transfer. The command field provides transfer operations.

Note: The command RAM is accessed only using the most significant byte of QDR and indirect addressing based on QAR[ADDR].

[Figure 16-10](#) shows the command RAM register.

Programming Model

	15	14	13	12	11	8	7	0
Field	CONT	BITSE	DT	DSCK	QSPI_CS	—		
Reset	Undefined							
R/W	Write Only							
Addresses	QAR[ADDR]							

Figure 16-10 Command RAM Registers (QCR0–QCR15)

Note: All QSPI registers must be accessed as 16-bits only.

Table 16-7 gives QCR field descriptions.

Table 16-7 QCR0–QCR15 Field Descriptions

BITS	NAME	DESCRIPTION
15	CONT	Continuous. 0 Chip selects return to inactive level defined by QWR[CSIV] when transfer is complete. 1 Chip selects remain asserted after the transfer of 16 words of data ¹ .
14	BITSE	Bits per transfer enable. 0 Eight bits 1 Number of bits set in QMR[BITS]
13	DT	Delay after transfer enable. 0 Default reset value. 1 The QSPI provides a variable delay at the end of serial transfer to facilitate interfacing with peripherals that have a latency requirement. The delay between transfers is determined by QDLYR[DTL].
12	DSCK	Chip select to QSPI_CLK delay enable. 0 Chip select valid to QSPI_CLK transition is one-half QSPI_CLK period. 1 QDLYR[QCD] specifies the delay from QSPI_CS valid to QSPI_CLK.
11–8	QSPI_CS	Peripheral chip selects. Used to select an external device for serial data transfer. More than one chip select may be active at once, and more than one device can be connected to each chip select.
7–0	—	Reserved, should be cleared.
<p>Note: 1. In order to keep the chip selects asserted for all transfers, the QWR [CSIV] bit must be set to control the level that the chip selects return to after the first transfer.</p>		

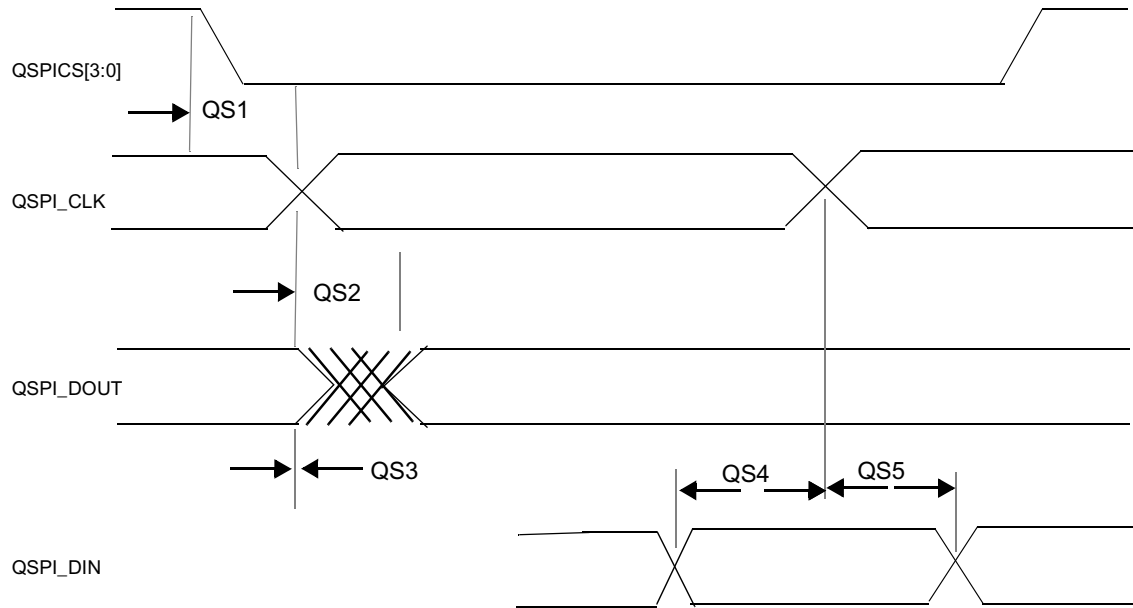

	Min	Max
QS1: QSPICS to QSPI_CLK	1T ¹	
QS2: QSPI_CLK to QSPI_DOUT VALID		20 ns
QS3: QSPI_CLK to QSPI_DOUT HOLD	0 ns	
QS4: QSPI_DIN to QSPI_CLK SETUP	10 ns	
QS5: QSPI_DIN to QSPI_CLK HOLD	10 ns	

¹ T1 is defined as the clock period in ns.

Figure 16-11 QSPI Timing

16.5.8 PROGRAMMING EXAMPLE

The following steps are necessary to set up the QSPI 12-bit data transfers and a QSPI_CLK of 4.125 MHz. The QSPI RAM is set up for a queue of 16 transfers. All four QSPI_CS signals are used in this example.

1. Enable QSPI_CLK and QSPI_DIN pin functionality by setting the QSPISEL bit in the PLLCR register.
2. Write the QMR with 0xB308 to set up 12-bit data words with the data shifted on the falling clock edge, and a clock frequency of 4.125 MHz (assuming a 66-MHz SYSCLK).
3. Write QDLYR with the desired delays.
4. Write QIR with 0xD00F to enable write collision, abort bus errors, and clear any interrupts.
5. Write QAR with 0x0020 to select the first command RAM entry.
6. Write QDR with 0x7E00, 0x7E00, 0x7E00, 0x7E00, 0x7D00, 0x7D00, 0x7D00, 0x7D00, 0x7B00, 0x7B00, 0x7B00, 0x7B00, 0x7700, 0x7700, 0x7700, and 0x7700 to set up four transfers for each chip select. The chip selects are active low in this example.
7. Write QAR with 0x0000 to select the first transmit RAM entry.
8. Write QDR with sixteen 12-bit words of data.
9. Write QWR with 0x0F00 to set up a queue beginning at entry 0 and ending at entry 15.

Programming Model

10. Set QDLYR[SPE] to enable the transfers.
11. Wait until the transfers are complete. QIR[SPIF] is set when the transfers are complete.
12. Write QAR with 0x0010 to select the first receive RAM entry.
13. Read QDR to get the received data for each transfer.
14. Repeat steps 5 through 13 to do another transfer.

Section 17

Audio Functions

17.1 AUDIO INTERFACE OVERVIEW

The audio interface module allows the MCF5249 to receive and transmit digital audio over serial audio interfaces (IIS/EIAJ) and over digital audio interfaces (IEC958).

The MCF5249 is equipped with four serial audio interfaces compliant with Philips IIS and Sony EIAJ format. The MCF5249 has two IEC958 receivers with 4 multiplexed inputs, and one IEC958 transmitter with two outputs: One for the professional C-channel and one for the consumer C-channel.

The audio interfaces block allows the direct retransmission of an audio signal received on one receiver to another transmitter, without CPU intervention, or it allows the CPU to receive or transmit digital audio to/from any of the audio interfaces.

The IEC958 receivers and transmitter support main audio. Also, the MCF5249 features allow the handling of IEC958 C and U channels.

A frequency measurement block exists to allow precise measurement of an incoming sampling frequency.

17.1.1 AUDIO INTERFACE STRUCTURE

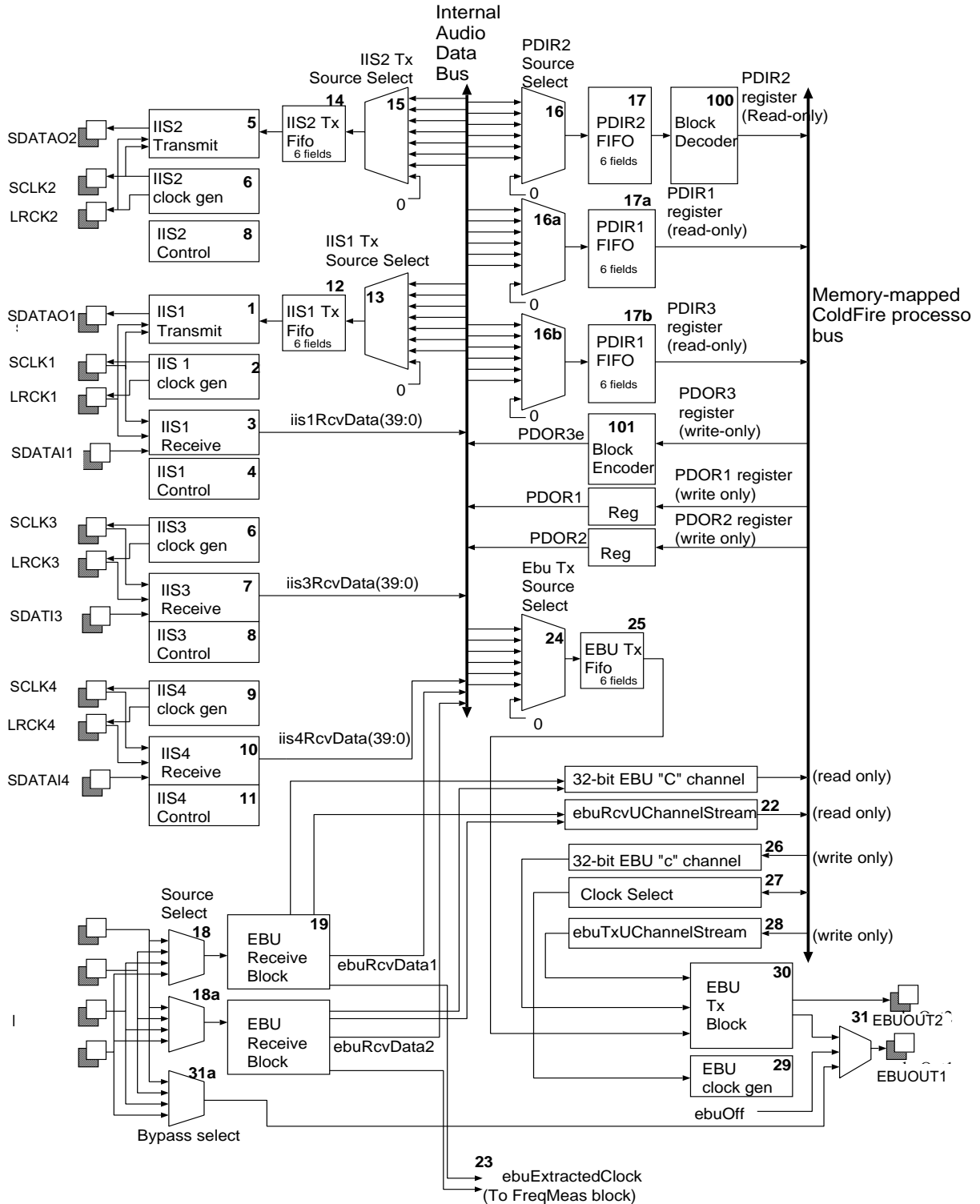

Figure 17-1 Audio Interface Block Diagram

There are four serial audio interface blocks labeled as follows:

1. IIS1: Capable of transmitting and receiving audio data.
2. IIS2: Transmit only.
3. IIS3: Receive only.
4. IIS4: Receive only.

As shown in [Figure 17-1](#), there are two IEC958 receivers. The source selector (**18**) and the receiver block itself (**19**). The receiver is capable of taking its input signal from four possible EBU inputs:

1. EBUIN1
2. EBUIN2
3. EBUIN3
4. EBUIN4

There is one IEC958 transmitter (**30**) with two outputs. One carries the “professional” C-channel, and the other carries the “consumer” C-channel.

Five audio interface receivers (IIS1, IIS3, IIS4, and two EBU receivers) send their received data on an internal 40-bit wide bus, the Internal Audio Data Bus. Every transmitter sources its data to be transmitted from this same internal bus. Every transmitter has a multiplexer to select the data source. Possible sources are (IIS1 receiver, IIS3 receiver, IIS4 receiver, two EBU receivers, processor data output1, processor data output2, processor data output 3). Every transmitter also has a FIFO after the multiplexer. This FIFO gives the data source some freedom when data is generated. The FIFOs compensate for phase shifts when a transmitter takes data from another receiver. In the case that the transmitter sends out processor-generated data, the FIFO allows the processor to send several audio words in one burst to the audio transmitter.

To allow the MCF5249 processor to receive and transmit audio data, an interface is present between the internal Audio Data Bus and the ColdFire memory space. As shown in [Figure 17-1](#), this interface is seen in the MCF5249 memory map as Processor Data Interface Registers. Three of these are Processor Data Out registers, PDOR1, PDOR2 and PDOR3. When the processor writes to one of these registers, the data is sent directly to the Internal Audio Data Bus, and depending on the setting of the multiplexers (**13**, **15**, and **24**) it will end up in one or several of the transmit FIFOs (**12**, **14**, and **25**). There are three Processor Data In registers, PDIR1, PDIR2, and PDIR3. When the processor reads from one of these address locations, it actually reads data from one of the FIFOs (**17**, **17a** or **17b**). These FIFOs receive data from the Internal Audio Data Bus using multiplexers (**16**, **16a** and **16b**). Depending on the setting of the multiplexers, data from one of the audio data receivers will end in the FIFOs. Possible receivers for the three PDIR channels are IIS1 receiver, IIS3 receiver, IIS4 receiver and the two IEC958 receivers.

Besides the mechanism to let the MCF5249 processor access the audio data, there are several interrupts and control registers to allow the MCF5249 to determine when it should read or write data to the appropriate processor data interface register.

The IEC958 receiver and transmitter handle the main data audio stream in the same way as the IIS receivers and transmitters. This is done using the internal Audio Data Bus. Additionally, they support the IEC958 “C” and “U” channels. IEC958 “C” and “U” channel data is interfaced directly to memory-mapped registers (**22,26,27** and **28**).

17.1.1.1 Audio Interrupt Mask and Interrupt Status Registers

The interrupts of the audio interface feed into vectors 0-31 of the interrupt controller. There are two sets of registers associated with interrupt operation.

Table 17-1 Interrupt Register Addresses

ADDRESS MBAR2+	NAME	WIDTH	DESCRIPTION	RESET VALUE	ACCESS
0x94:0x97	InterruptEn	32	Interrupt enable register	0	RW
0x98:0x9B	InterruptStat	32	Interrupt status register	-	R
0x98:0x9B	InterruptClear	32	Interrupt clear register	-	W
0xE4:0xE7	InterruptEn3	32	Interrupt enable register		RW
0xE0:0xE3	InterruptStat3	32	Interrupt status register	-	R
0xE0:0xE3	InterruptClear3	32	Interrupt clear register	-	W

Every pending audio interrupt will show up as a '1' in register InterruptStat or InterruptStat3. The interrupt will cause the associated interrupt to go active if the corresponding bit in InterruptEn is set to '1'. Most interrupts are cleared by writing a '1' to the corresponding bit in InterruptClear register.

Table 17-2 Interrupt Register Description

BIT	INTERRUPT NAME	DESCRIPTION	VECTOR	HOW TO CLEAR
31	IIS1TXUNOV	iis1 transmit fifo under / over	31	reg. IntClear
30	IIS1TXRESYN	iis1 transmit fifo resync	30	reg. IntClear
29	IIS2TXUNOV	iis2 transmit fifo under / over	29	reg. IntClear
28	IIS2TXRESYN	iis2 transmit fifo resync	28	reg. IntClear
27	EBUTXUNOV	IEC958 transmit fifo under / over	27	reg. IntClear
26	EBUTXRESYN	IEC958 transmit fifo resync	26	reg. IntClear
25	EBU1CNEW	IEC958-1 receiver new C channel received	25	reg. IntClear
24	EBU1VALNOGOOD	IEC958-1 receiver validity bit not set	24	reg. IntClear
23	EBU1SYMERR	IEC958-1 receiver symbol error	23	reg. IntClear
22	EBU1BITERR	IEC958-1 receiver parity bit error	23	reg. IntClear
21	UCHANTXEMPTY	U channel transmit register is empty	21	write to tx reg
20	UCHANTXUNDER	U channel transmit register underrun	20	reg. IntClear
19	UCHANTX NEXTFIRST	U channel transmit register next byte will be first	19	write to Tx reg
18	U1CHANRCVFULL	<i>U1ChannelReceive</i> register full	18	read Rcv reg
17	U1CHANRCVOVER	<i>U1ChannelReceive</i> register overrun	23	reg. IntClear
16	Q1CHANRCVFULL	<i>Q1ChannelReceive</i> register full	18	read rcv reg
15	Q1CHANRCVOVER	<i>Q1ChannelReceive</i> register overrun	13	reg. IntClear
14	UQ1CHANSYNC	U/Q channel sync found	18	reg. IntClear
13	UQ1CHANERR	U/Q channel framing error	13	reg IntClear
12	PDIR1UNOV	processor data in 1 under / over	12	reg IntClear

Table 17-2 Interrupt Register Description (Continued)

BIT	INTERRUPT NAME	DESCRIPTION	VECTOR	HOW TO CLEAR
11	PDIR1RESYN	processor data in 1 resync	11	reg IntClear
10	PDIR2UNOV	Processor data in 2 under / over	10	reg IntClear
9	PDIR2RESYN	Processor data in 2 resync	9	reg IntClear
8	AUDIOTICK	“tick” interrupt	8	reg IntClear
7	U2CHANRCVOVER Q2CHANOVERRUN UQ2CHANERR	IEC 958 receiver 2 U/Q channel error	7	reg IntClear
6	PDIR3 RESYNC	Processor data in 3 resync	6	reg IntClear
5	PDIR3 FULL	Processor data in 3 full	5	read fromPDIR3
4	IIS1TXEMPTY	IIS1 transmit fifo empty	4	write to FIFO
3	IIS2TXEMPTY	IIS2 transmit fifo empty	3	write to FIFO
2	EBUTXEMPTY	ebu transmit fifo empty	2	write to FIFO
1	PDIR2 FULL	Processor data in 2 full	1	read from PDIR2
0	PDIR1 FULL	Processor data in 1 full	0	read from PDIR1

Table 17-3 InterruptEn3 InterruptClear3, InterruptStat3 Register Description

BIT	INTERRUPT NAME	DESCRIPTION	VECTOR	HOW TO CLEAR
25	EBU2CNEW	IEC958-2 receiver new C channel received	17	reg. IntClear3
24	EBU2VALNOGOOD	IEC958-2 receiver validity bit not set	16	reg. IntClear3
23	EBU2SYMERR	IEC958-2 receiver symbol error	15	reg. IntClear3
22	EBU2BITERR	IEC958-2 receiver parity bit error	15	reg. IntClear3
18	UCHANRCVFULL	<i>U2ChannelReceive</i> register full	14	read rcv reg
17	UCHANRCVOVER	<i>U2ChannelReceive</i> register overrun	7	reg. IntClear3
16	QCHANRVFULL	<i>Q2ChannelReceive</i> register full	14	read rcv reg
15	QCHANOVERRUN	<i>Q2ChannelReceive</i> register overrun	7	reg. IntClear3
14	UQCHANSYNC	U/Q2 channel sync found	14	reg. IntClear3
13	UQCHANERR	U/Q2 channel framing error	7	reg IntClear3

17.2 SERIAL AUDIO INTERFACE (IIS/EIAJ)

There are a total of four serial audio interfaces. Each interface can handle Philips IIS or Sony EIAJ protocol. Interface 1 is a receive/transmit interface. Interface 2 is transmit only, Interfaces 3 and 4 are receive only. See [Table 17-4](#). Interface 1 has four pins connected, the others have three pins. Every serial audio interface block has a 32-bit configuration register associated with it.

Freescale Semiconductor, Inc.

Serial Audio Interface (IIS/EIAJ)

Note: Each of the four IIS interfaces is capable of operating in Philips IIS mode or Sony EIAJ mode with either 32, 36, or 40 bits per word clock. Timing diagrams describing each of these modes are given in the following sections. The frequency of the clock and data signals is programmable, as is the inversion of the bit clock (SCLK) or word clock (LRCK) for each IIS interface. Inversion of the LRCK clock only operates correctly on a slave receiver, therefore IIS3 IIS4. If IIS1 is being used for transmit and receive in master mode then LRCK will be inverted on both the input and the output. Thereby cancelling the effect.

The SCLK and LRCK signals for each IIS interface can be inputs to the interface or they can be generated internally. See [Table 17-7](#)

Table 17-4 IIS1 Configuration Registers (0x10)

BITS	31	30	29	28	27	26	25	24	23	22	21	20	19	18	17	16
FIELD														EF/CFLG INSERT	CFLG SAMPLE POSITION	TXSOURCE SELECT
RESET	0	0	0	0	0	0	0	0	0	0		0	0	0	0	0
R/W	R/W															
BITS	15	14	13	12	11	10	9	8	7	6	5	4	3	2	1	0
FIELD	CLOCKSEL				TX FIFO CONTROL	TXSOURCE SELECT			SIZE		MODE	LRCK FREQUENCY			LRCK INVERT	SCLK INVERT
RESET	0	0	0	0	1	1	1	1	1	1		0	1	0	0	0
R/W	R/W															
ADDR	(IIS1config) MBAR2 + 0x10 (reset 0x0fc8)															

Table 17-5 IIS2 Configuration Registers (0x14)

BITS	31	30	29	28	27	26	25	24	23	22	21	20	19	18	17	16
FIELD																TXSOURCE SELECT
RESET	0	0	0	0	0	0	0	0	0	0		0	1	0	0	0
R/W	R/W															
BITS	15	14	13	12	11	10	9	8	7	6	5	4	3	2	1	0
FIELD	CLOCKSEL				TX FIFO CONTROL	TXSOURCE SELECT			SIZE		MODE	LRCK FREQUENCY			LRCK INVERT	SCLK INVERT
RESET	0	0	0	0	1	1	1	1	1	1		0	1	0	0	0
R/W	R/W															
ADDR	(IIS2config) MBAR2 + 0x14 (reset 0x0fc8)															

Table 17-6 IIS3,4 Configuration Registers (0x18, 0x1C)

BITS	31	30	29	28	27	26	25	24	23	22	21	20	19	18	17	16
FIELD																
RESET	0	0	0	0	1	0	0	0	0	0		0	0	0	0	0
R/W	R/W															

Table 17-6 IIS3,4 Configuration Registers (0x18, 0x1C) (Continued)

BITS	15	14	13	12	11	10	9	8	7	6	5	4	3	2	1	0
FIELD	CLOCKSEL									SIZE	MODE	LRCK FREQUENCY			LRCK INVERT	SCLK INVERT
RESET	0	0	0	0	1	1	1	1	1	1		0	1	0	0	0
R/W	R/W															
ADDR	(IIS3config) MBAR2 + 0x18 (reset 0x0fc8) (IIS4config) MBAR2 + 0x1C (reset 0x0fc8)															

Table 17-7 IIS Configuration Bit Descriptions

BIT NAME	BITS	DESCRIPTION
EF/CFLG insert	18	See note 16 0: not active 1: active
CFLG sample position	17	See note 16 0: sample CFLG input 1 SCLK clock after incoming LRCK edge 1: sample CFLG input 6 SCLK clocks before incoming LRCK edge
CLOCKSEL	15,14,13,12	See notes 1, 11, and 14 following bit these descriptions. 0000: SCLK/LRCK is input 0001: SCLK: Audio Clk / 24 0010: SCLK: Audio Clk / 16 0011: SCLK: Audio Clk / 12 0100: SCLK: Audio Clk / 8 0101: SCLK: Audio Clk / 6 0110: SCLK: Audio Clk / 4 0111: SCLK: Audio Clk / 3 1100: SCLK: Audio Clk / 2 1000: SCLK, LRCK: follow IIS1 1001: SCLK, LRCK: follow IIS2 1010: SCLK, LRCK: follow IIS3 1011: SCLK, LRCK: follow IIS4
TX FIFO CONTROL	11	See notes 2, 7, 13, and 15 following these bit descriptions. 1: reset to 1 sample remaining 0: normal operation
TXSOURCE SELECT	16,10,9,8	See notes 2, 9, 12, and 15 following bit these descriptions. Bits 16, 10-8 0 000: Digital zero 0 001: PDOR1 0 010: PDOR2 0 011: PDOR3 0 100: IIS1 RcvData 0 101: IIS3 RcvData 0 110: IIS4 RcvData 0 111: EBU RcvData 1 000: EBU2 RcvData

Table 17-7 IIS Configuration Bit Descriptions (Continued)

BIT NAME	BITS	DESCRIPTION
SIZE	7,6	See notes 3, 4, and 8 following bit these descriptions. 00: 16 bits 01: 18 bits 10: 20 bits 11: zero
MODE	5	1 = Sony, EIAJ mode 0 = Philips IIS mode
LRCK FREQUENCY	4,.3,2	100: 64 bit clocks / word clock 010: 48 bit clocks / word clock 000: 32 bit clocks / word clock Other settings: reserved, undefined
LRCK INVERT	1	See note 5 following bit these descriptions. 1 = Invert on word clock 0 = No invert on word clock
SCLK INVERT	0	See note 6 following bit these descriptions. 1 = Invert on bit clock 0 = No invert on bit clock
Note:	1. Audio Clk is normally 16.93 MHz. Actual value given Table 4-4 on page 4-5 . When divided SYSCLOCK is selected as SCLK output, LRCK will be output too, and is divided from SCLK, using division factor defined by field 4,3,2 - <i>LRCK frequency</i> .	
Note:	2. When bit 11 is set, FIFO is in reset condition. The FIFO is always re-set to "1 sample remaining". The value of the remaining one sample will be all-zero.	
Note:	3. When Philips IIS mode is selected, 16-18-20 bits should yield same result.	
Note:	4. Internal interface in MCF5249 is 40 bits / sample (20 left + 20 right). 16, 18 bit words are padded with zeros	
Note:	5. LRCK invert will invert the incoming LRCK signal between the pin and the serial data receiver and transmitter	
Note:	6. SCLK invert will invert the incoming SCLK signal between the pin and the serial data receiver and transmitter.	
Note:	7. Reset to one sample remaining is used to synchronize the data transfer from one input interface to another output interface running at the same frequency.	
Note:	8. "zero" means data is transferred at the sampling frequency, with all data cleared down to digital zero.	
Note:	9. PDOR1, PDOR2, PDOR3: ColdFire data out registers.	
Note:	10. Serial data transmit / receive interfaces have no limit on minimum incoming or outgoing sampling frequency. The maximum SCLK frequency is limited to 1/3 of the internal system clock (CPUclk/2). Mark/space ratio should be equal or better than 38/62.	
Note:	11. Reprogramming bits 15-12 during functional operation is not allowed. Reprogramming only allowed while FIFO is in reset condition (bit 11 set '1')	
Note:	12. When "digital zero" is selected as source, the FIFO outputs "zero" on its outgoing data bus, regardless of the input side and content of the FIFO. No FIFO related exceptions are generated.	
Note:	13. When the FIFO leaves the reset state, because the user writes a "normal operation" state into the control register, while previous state was reset state, the FIFO is kept in reset until the first long-word is written to it . As a result, the "start" of the normal operation is synchronized with the writing of the first data into the fifo.	
Note:	14. When IIS/Sony interface LRCK/SCLK is set in "follow IIS" mode, the bit clock and word clock become exactly identical to bit and word clock of followed interface. If e.g. LRCK/SCLK for IIS interface 2 is set in "follow IIS1", the DAC or AD connected to IIS2 can use bit clock and word clock of IIS1. Bit and word clock for IIS2 can be used as gpio.	
Note:	15. Bit 16 extends the Tx FIFO control bit and the bit order becomes 16, 10, 9, 8.	
Note:	16. These bits should be programmed zero for normal operation. For interface1 receiver, it is possible to use the special EF/CFLG insertion mode, by setting bit 18 = 1. This mode is intended to interface with Philips CD decoders (SAA7345 and successors). When this mode is used, IIS1CONFIG must be programmed to "Sony" mode, 16 bits. The SAA7345 must also be programmed to "Sony" mode, 16 bits. The CFLG flag coming from SAA7345 must be connected with CFLG input. The EF flag coming from SAA7345 must be connected with EF input. If all this is done correctly, the device will receive the 16 MSB 's of the incoming data in bits [17:2] of the received serial data. Bit [1] of the received data is the EF flag of the corresponding word, as output by SAA7345. Bit [1] will be set if the MSB or the LSB or both are flagged. Bit [0] of the received data is the CFLG flag of the corresponding word, as output by SAA7345. These flags can be used for implementing an electronic shock protection FIFO.	

17.2.1 IIS/EIAJ TRANSMITTER DESCRIPTIONS

The two IIS/EIAJ transmitters operate independently. Each of the transmitters has the capability of transmitting data from one of several sources:

- One of the three processor data out registers.
- One of the three IIS receivers.
- The digital audio (EBU) receiver.
- Digital zero.

The source of the transmit data is programmable.

17.2.2 IIS/EIAJ TRANSMITTER INTERRUPTS

There are a number of exceptions defined within the serial audio interface transmitters:

- Serial audio interface1 transmit FIFO overrun or underrun
- Serial audio interface1 transmit FIFO left/right resynchronization
- Serial audio interface1 transmit FIFO empty
- Serial audio interface 2 transmit FIFO overrun or underrun
- Serial audio interface 2 transmit FIFO left/right resynchronization
- Serial audio interface 2 transmit FIFO empty

The action of the IIS transmitters on FIFO underrun is to repeat the last sample.

Timing diagrams for IIS/EIAJ mode are shown in [Figure 17-2](#) and [Figure 17-3](#). Data out and word clock out is clocked on the falling edge of the SCLK bit clock (noninverted).

17.2.3 IIS/EIAJ RECEIVER DESCRIPTIONS

Each of the three IIS receivers operates independently. For timing diagrams, see [Figure 17-2](#) and [Figure 17-3](#). The data can be clocked into each receiver using an external SCLK/LRCK or using an internally-generated SCLK/LRCK. Data is always clocked on the rising edge of the SCLK bit clock (noninverted).

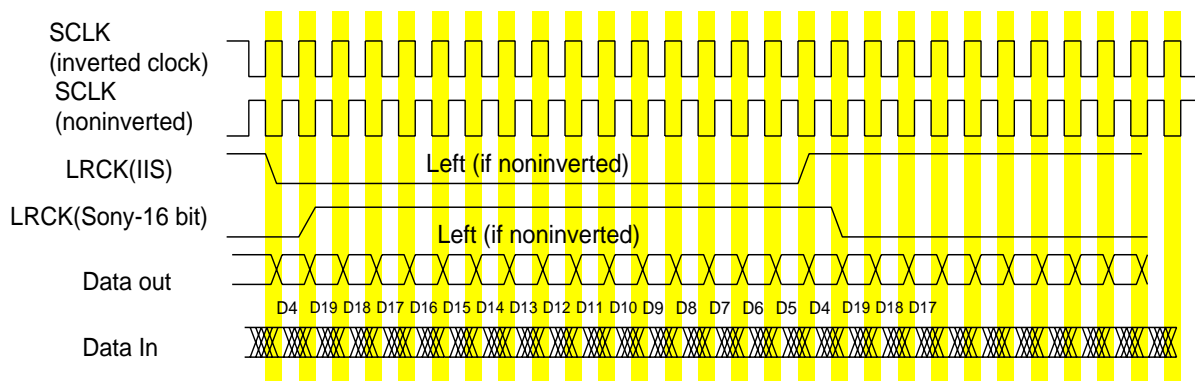

Figure 17-2 IIS/EIAJ Timing Diagram (16 SCLK edges per word)

Freescale Semiconductor, Inc.
Digital Audio Interface (EBU)

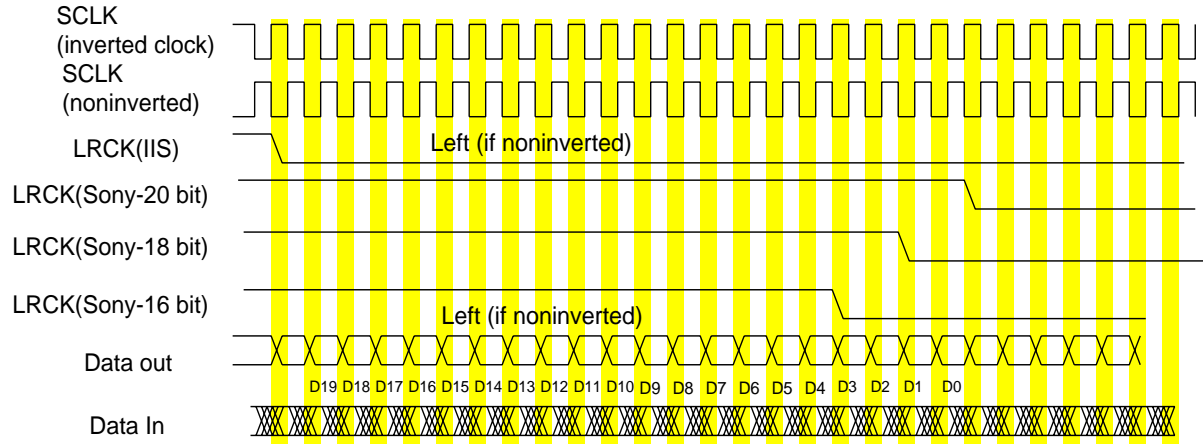

Figure 17-3 IIS/EIAJ timing diagram (24 or 32 SCLK edges per word)

Note: In 18-bit mode, bits D1 and D0 are set 0.
 In 16-bit mode, bits D3,D2,D1 and D0 are set 0.

17.3 DIGITAL AUDIO INTERFACE (EBU)

Table 17-8 EBU1Config Register

BITS	16	15	14	13	12	11	10	9	8	7	6	5	4	3	2	1	0	
FIELD	TX SOURCE SELECT		CLOCKSEL				TX FIFO CONTROL		TX SOURCE SELECT		IEC958 RECEIVE SOURCE SELECT		VAL CONTROL		IEC958 OUT SELECT		U SOURCE SELECT	
RESET		0	0	1	1	1	1	1	1	0	0	0	0	0	0	0	0	
R/W	R/W																	
ADDR	MBAR2 + 0X20:0X23 (RESET 0X3F00)																	

Table 17-9 EBU1Config Register Bit Descriptions

FIELD - BITS	NAME	DESCRIPTION	RESET	NOTES
15,14,13,12	CLOCKSEL	0000: IEC958 clock: audioclk / 16 0001: IEC958 clock: audioclk / 12 0010: IEC958 clock: audioclk / 8 0011: IEC958 clock: audioclk / 6 0100: IEC958 clock: audioclk / 4 0101: IEC958 clock: audioclk / 3 0110: IEC958 clock: sclk1 0111: IEC958 clock: sclk2 1000: IEC958 clock: sclk3 1001: IEC958 clock: sclk4	0011	1,2,8
11	TX FIFO CONTROL	1: reset to one sample remaining 0: normal operation	1111	3,5,11
16,10,9,8	TXSOURCE SELECT	0 000: digital zero 0 001: PDOR1 0 010: PDOR2 0 011: PDOR3 0 100: iis1RcvData 0 101: iis3RcvData 0 110: iis4RcvData 0 111: ebu1RcvData 1 000: ebu2RcvData	1111	3,6,9
7,6	IEC958 RECEIVE SOURCE SELECT	00: EBU in 1 01: EBU in 2 10: EBU in 3 11: EBU in 4	00	
5	VALCONTROL	0: Outgoing "V" flag always 1 1: Outgoing "V" flag always 0	0	10
4,3,2	IEC958 OUT SELECT	000: Off. Output "0" 001: feed-through EBUIn1 010: feed-through EBUIn2 011: feed-through EBUIn3 100: feed-through EBUIn4 101: normal operation	000	12

Table 17-9 EBU1Config Register Bit Descriptions (Continued)

FIELD - BITS	NAME	DESCRIPTION	RESET	NOTES
1,0	U SOURCE SELECT	00: No embedded U channel 01: U channel from IEC958 receive block. (CD mode) 10: Reserved, undefined 11: U channel from on-chip U channel transmitter.	00	4
<p>1. IEC958 interface needs 64 * audio sample frequency clock for good operation. This is 2.822 Mhz for operation at 44.1 Khz sampling frequency.</p> <p>2. When IEC958 is set to follow SCLK1, SCLK2, SCLK3 OR SCLK4, IEC958 will transmit at same rate as serial audio interface only if the interface uses 64 bit clocks / word clock format.</p> <p>3. When bit 11 is set, FIFO is in reset condition. The FIFO is always re-set to "contains 1 sample". This sample value is re-set at the same time to "all-zero".</p> <p>4. U channel selection is described on section handling subcode processing.</p> <p>5. Application info. Before starting IEC958 transmission to copy data from another incoming channel, first reset the FIFO to one sample remaining, while source selector is set to correct source. When FIFO is switched to normal operation, transmission will start normally.</p> <p>6. Digital zero means data transmitted is digital zero, while "C" and "U" channel contain valid data. When digital zero is transmitted, IEC958 transmit fifo is not read any more by IEC958 transmit hardware.</p> <p>7. PDOR1, PDOR2, PDOR3: ColdFire data out register.</p> <p>8. Reprogramming bits 15-12 during functional operation is not allowed. Reprogramming only allowed while FIFO is in reset condition (bit 11 set '1')</p> <p>9. When "digital zero" is selected as source, the FIFO outputs "zero" on its outgoing data bus, regardless of the input side and content of the FIFO. No FIFO related exceptions are generated.</p> <p>10. This bit controls the outgoing validity flag of the EBU transmitter. When it is re-set, all outgoing data is flagged as "valid". If it is set, all data is flagged "invalid".</p> <p>11. When the FIFO leaves the reset state, because the user write a "normal operation" state into the control register, while previous state was reset state, the FIFO is kept into reset until first long-word is written to it. As a result, the "start" of the normal operation is synchronized with the writing of the first data into the fifo.</p> <p>12. This field selects what is output on EBUOUT1. If field is "000," the SPDIF output is off, outputs 0. If field is "001" to "100," it muxes out one of the EBUIN's to the EBUOUT, without any reformatting. When the field is set to "101," this is normal operation of the SPDIF transmitter.</p>				

Table 17-10 EBU2Config Register

BITS	16	15	14	13	12	11	10	9	8	7	6	5	4	3	2	1	0
FIELD									IEC958 RECEIVE SOURCE SELECT								
RESET		0	0	1	1	1	1	1	1	0	0	00	0	0	0	0	0
R/W	R/W																
ADDR	MBAR2 + 0XD0: 0XD3 (RESET 0X3F00)																

Table 17-11 EBU2Config Register Bit Descriptions

FIELD - BITS	NAME	DESCRIPTION	RESET	NOTES
7,6	IEC958 RECEIVE SOURCE SELECT	00: EBU in 1 01: EBU in 2 10: EBU in 3 11: EBU in 4	00	

17.3.1 IEC958 RECEIVE INTERFACE

The IEC958 receive interface consists of 2 blocks:

1. The source selector
2. The IEC958 receiver itself

The source is selected by programming the appropriate EBU Control Register bits 7:6. The receiver then extracts the data from the stream and outputs the data on the internal audio bus. The data can then be used by the processor (using the PDIR and other registers) or by the IIS or EBU transmit interface. In the case of the data being used as input to one of the IIS transmitters, the data rate of the incoming EBU data must match exactly with that of the IIS transmitter. The following functions are performed by the block.

17.3.1.1 Audio Data Reception

The IEC958 receive block (19) extracts the audio data from the stream and puts this in 20-bit format on Internal Audio Data bus. The format is exactly the same as the format produced by the serial data interfaces.

17.3.1.2 Control Channel Reception

For a description of the control (or “C”) channel in EBU data formatting, refer to IEC958-3 description of control channel. There are two 32-bit registers, one for each receiver, which receive the first 32 bits of the “C” channel. No interpretation is done. See [Table 17-12](#)

Table 17-12 EBURcvCChannel Register

BITS	31	30	29	28	27	26	25	24	23	22	21	20	19	18	17	16
FIELD	EBURCVCHANNEL1 AND CHANNEL2															
RESET	-	-	-	-	-	-	-	-	-	-	-	-	-	-	-	-
R/W	READ ONLY															
BITS	15	14	13	12	11	10	9	8	7	6	5	4	3	2	1	0
FIELD	EBURCVCHANNEL1 AND CHANNEL2															
RESET	-	-	-	-	-	-	-	-	-	-	-	-	-	-	-	-
R/W	READ ONLY															
ADDR	EBU1RCVCHANNEL MBAR2 + 0X24: EBU2RCVCHANNEL MBAR2 + 0XD4:															

Bits are ordered first bit left. So, C-channel bit “0” is seen in bit position 31 in the EBURcvCChannel register. C-channel bit “31” is seen as the LSB bit in the register.

17.3.1.3 Control Channel Interrupt (IEC958 “C” Channel New Frame)

When the value of a new IEC958 “c” channel frame is loaded into the EBURcvCChannel register, an interrupt is generated. This interrupt is cleared when the processor writes the corresponding bit in the InterruptClear register. EBURcvCChannel is double buffered. Meaningful values can be read at any time.

17.3.1.4 Validity Flag Reception

An interrupt is associated with the Validity flag. (interrupt 24 - IEC958ValNoGood). This interrupt is set every time a frame is seen on the IEC958 interface with the validity bit set to “invalid”.

Freescale Semiconductor, Inc.

Digital Audio Interface (EBU)

17.3.1.5 IEC958 Exception Definition

There are several IEC958 exceptions defined that will trigger an interrupt. These are:

- Control channel change — Set when EBUrcvCChannel register is updated. The register is updated for every new C-Channel received. The exception is reset when EBUrcvCChannel register is read.
- EBU Illegal Symbol — Set on reception of illegal symbol during IEC958 receive. Reset by writing register InterruptClear. Refer to the section on interrupts for details. The EBU input is a biphasic/mark modulated signal. The time between any two successive transitions of the EBU signal is always 1, 2 or 3 EBU symbol periods long. The EBU receiver will parse the stream, and split it in so-called symbols. It recognizes s1, s2 and s3 symbols, depending on the length of the symbols. Not all sequences of these symbols are allowed. To give an example, a sequence s2-s1-s1-s1-s2 cannot occur in a error-free EBU signal. If the receiver finds such an illegal sequence, the *illegal symbol* interrupt is set. No corrective action is undertaken.

When the interrupt occurs, this means that

- (a) The EBU signal is destroyed by noise
- (b) The EBU frequency changed.
- IEC958 bit error — Set on reception of bit error. (Parity bit does not match). Reset on write to InterruptClear register. Refer to the section on interrupts for details.

17.3.1.6 EBU Extracted Clock

The clock from the EBU signal is extracted for measurement purposes only. It cannot be used as a clock to drive other audio interfaces like IIS. The average rate is 128 x the sampling frequency (ex. 128 * 44.1 KHz for 44.1 KHz input sampling frequency). The internal signal is used in the FreqMeas circuit to generate the frequency measurement.

17.3.1.7 Reception of User Channel and CD-subcode Over IEC958 Receiver

The IEC958 receiver is capable of extracting the User Channel bits out of the data stream. The extracted bits are assembled in the 32-bit "*UChannelReceive*" register, with the first U-Channel bit in the MSB position (bit 31). The interface can be configured to detect Sync patterns in the U-Channel in the case the U-Channel contains CD subcode (CD-mode). The Sync Detection can be enabled by setting the USyncMode bits in the CD-Subcode register (Table 17-15). Sync recognition is done as follows:

- Internally, a symbol starting with a "1" is treated as a "data symbol". Any consecutive 11 zeros are treated as a "zero symbol"
- The sync detector will assume User Channel sync whenever:
 - (a) A sequence of 4 symbols, data-sync-sync-data, is found.
 - (b) 98 symbols (does not matter data or zero) after the previous "sync symbols"
- The *ChannelLengthError* interrupt is set when a new sync is not found at the correct distance from the previous sync, or if *UChannelReceive* or *QChannelReceive* do not contain the correct number of bits/bytes.

Furthermore, in CD-mode, the Q-channel receiver extracts the Q-channel CD-Subcode from the U-Channel stream and assembles the bits in the 32-bit "*QChannelReceive*" with the first bit in the MSB position.

Associated registers are shown in the following table:

Table 17-13 UChannel Receive and QChannel Receive Registers

BITS	31	30	29	28	27	26	25	24	23	22	21	20	19	18	17	16
FIELD	UCHANNEL RECEIVE 1 AND 2 QCHANNEL RECEIVE 1 AND 2															
RESET	UNDEFINED															
R/W	READ ONLY															
BITS	15	14	13	12	11	10	9	8	7	6	5	4	3	2	1	0
FIELD	UCHANNEL RECEIVE 1 AND 2 QCHANNEL RECEIVE 1 AND 2															
RESET	UNDEFINED															
R/W	READ ONLY															
ADDR	MBAR2 + 0X88: 0X8B (U CHANNEL1) MBAR2 + 0XD8: 0XDB (U CHANNEL2) MBAR2 + 0X8C: 0X8F (Q CHANNEL 1) MBAR2 + 0XDC: 0XDF (Q CHANNEL 2)															

Table 17-14 U Channel Receive and Q Channel Receive Bit Descriptions

BIT NAME	DESCRIPTION
UCHANNEL RECEIVE 1 AND 2	U channel receive register. Contains next 4 U channel bytes.
QCHANNEL RECEIVE 1 AND 2	Q channel receive register. Contains next 4 Q channel bytes.

Table 17-15 CDTEXTCONTROL

BITS	15	14	13	12	11	10	9	8	7	6	5	4	3	2	1	0
FIELD	PRESETEN	PRESETCOUNT(6:0)												USync Mode EBU2	USync Mode EBU1	UCHANTXTIM
RESET	0	0	0	0	0	0	0	0	0	0	0	0	0	0	0	0
R/W	R/W															
ADDR	MBAR2 + 0X92															

Table 17-16 CD-Subcode Register Bit Descriptions

FIELD BITS	MODE	DESCRIPTION	NOTES
15	PRESETEN	1: preset free-running sync position counter 0: no action on free-running sync position counter.	2,3
14:8	PRESETCOUNT (6:0)	sync presetting count	1,3
2	USYNCMODE EBU2	1: CD user channel reception 0: Other data.	

Table 17-16 CD-Subcode Register Bit Descriptions (Continued)

FIELD BITS	MODE	DESCRIPTION	NOTES
1	USYNCMODE EBU1	1: CD user channel reception 0: Other data.	
0	UCHANTXTIM	0: Timing to reg. <i>UChannelTx</i> from cd-text output interface 1: Timing to reg. <i>UChannelTx</i> from EBU1 output interface	
1. On read back, last written value is returned 2. On read back, zero is returned 3. PRESETCOUNT(6:0) will only affect the free running counter when the register is written with PRESETEN = '1'. Writing with PRESETEN = '0' does not affect the counter.			

17.3.1.8 U and Q Receive Register Interrupts

- UChannelRcvFull — Receive register full
- UChannelRcvOverrun — Overrun error
- QChannelRcvFull — Receive register full
- QChannelOverrun — Overrun error on Q channel
- ChannelSyncFound — Received sync on U/Q channel.
- ChannelLengthError — Set when ChannelSyncFound occurs when there are less than 32 bits waiting in QchannelReceive register, or less than 4 bytes in UChannelReceive, or when a syncing error is found. To regain correct syncing, U channel receive register and Q channel receive register must be read to establish correct synchronization.

On the input interface, 2 data receive registers are defined:

1. UChannelReceive — 32-bit register to receive incoming subcode.
2. QChannelReceive — 32-bit register to receive Q channel of incoming subcode.

The hardware associated with IEC958 receiver U-channel reception is intended for reception of the following kind of data:

- CD or CD-compatible User channel subcode (P,Q and R-W, or Q and R-W). See the CD Red Book specification for a detailed description.
- Other types of subcode.

17.3.1.9 Behavior of User Channel Receive Interface (CD Data)

This section details the behavior of the user channel receive interface on incoming CD user channel subcode in the IEC958 receiver. This mode is selected if UsyncMode (bit 1) in register CD-Subcode control, is set.

The CD subcode stream embedded into the IEC958 User channel consists of a sequence of packets. Every packet contains 98 symbols. The first two symbols of every packet are sync symbols and the other 96 symbols are data symbols.

Any sequence found in the IEC958 U-channel stream starting with a leading one, followed by 7 information bits, is recognized as a data symbol. Subsequent data symbols are separated by pauses. During the pause, zero bits are seen on the IEC958 U-channel.

Data symbols come in MSB first. The MSB is the leading one and is always received as bit 7.

When a long pause is seen between two subsequent data symbols, the IEC958 receiver assumes the reception of one or more sync symbols. Table 17-17 shows this functionality.

Table 17-17 Correlation Between Zero Bits and Sync Symbols

NO OF U CHANNEL ZERO BITS	CORRESPONDING NUMBER OF SYNC SYMBOLS
0-1	unpredictable, not allowed
2-10	0
11-22	1
23-34	2
35-45	3
> 45	unpredictable, not allowed

The recognition of the number of sync symbols derives from the fact that the U-channel transmitter in the CD channel decoder will transmit one symbol on average every 12 IEC958 channel bits. On this average rate, there is a tolerance of maximum 5%.

The IEC958 receiver is tolerant on symbol error. Due to the physical nature of the transmission of the data over the CD disc, not more than one out of any 5 consecutive user channel symbols may be in error. The error may cause a change in data value, which is not treated by this interface, or it may cause a data symbol to be seen as a sync symbol, or a sync symbol to be seen as a data symbol. However, not more than one out of any 5 consecutive user channel symbols can be affected in this way.

The IEC958 User channel circuitry will recognize the 98-symbol packet structure, and send the 96 symbol payload to the ColdFire application. The 96 symbol payload is transmitted to the ColdFire using 2 registers:

- The UChannelRcv register — In this register, data is presented 4 symbols at a time to the ColdFire processor. Every time 4 new valid symbols, received on the IEC958 U-Channel, are present, the UChannelRcvFull interrupt is asserted. For one 98-symbol packet, 96 symbols are carried across UChannelRcv. To transfer all this data, 24 UChannelRcvFull interrupts are generated.
- The QChannelRcv register — In this register, only the Q bit of the packet is accumulated. Operation is similar to UChannelRcv. Because only Q-bit is transferred, only 96 Q-bits are transferred for any 98-symbol packet. To transfer this data, 3 QChannelRcvFull interrupts are generated. When QChannelRcvFull occurs, it is coincident with UChannelRcvFull. There is only one QChannelRcvFull for every 8 UChannelRcvFull. The convention is that the most significant data is transmitted first, and is left-aligned in the registers.

The timing, as it applies to packet boundary, is extracted by hardware. The last UChannelRcvFull corresponding to a given packet should be coincident with the last QChannelRcvFull. In this last U, Q channel interrupt, symbols 95-98 are received, as are Q-channel bits 67-98. The interrupts are coincident with ChannelSyncFound, flagging the last symbols of the current frame.

When the start of a new packet is found before the current packet is complete (less than 98 symbols in the packet), the ChannelLengthError interrupt is set. The application software should read out UChannelRcv and QchannelRcv registers, discard the value, and assume the start of a new packet.

Freescale Semiconductor, Inc.

Digital Audio Interface (EBU)

As previously mentioned, packet sync extraction is tolerant for single-symbol errors. Packet sync detection is based on the recognition of the sequence data-sync-sync-data in the symbol stream, because this is the only syncing sequence that is not affected by single errors. If the sync symbol is not found 98 symbols after the previous occurrence, it is assumed to be destroyed by channel error, and a new sync symbol is interpolated.

Normally, only data bytes are passed to the application software. Every data byte will have its most significant bit set. If sync symbols are passed to the application software (i.e., the processor), they are seen as all-zero symbols. Sync symbols can only end up in the data stream due to channel error.

17.3.1.10 Behavior of User Channel Receive Interface (non-CD data)

This section details the behavior of the user channel receive interface on incoming non-CD data.

This mode is selected if UsyncMode (bit 1) in register CD Text control is set '0'.

In non-CD mode, the IEC958 User channel stream is recognized as a sequence of data symbols. No packet recognition is done.

Any sequence found in the IEC958 U-channel stream starting with a leading one, followed by 7 information bits, is recognized as a data symbol. Subsequent data symbols are separated by pauses. During the pause, zero bits are seen on the IEC958 U-channel.

Four consecutive data symbols seen in the IEC958 U-Channel stream are grouped together into the UChannelRcv register. First symbol is left, last symbol is right aligned. Whenever UChannelRcv contains 4 new data symbols, UChannelRcvFull is asserted.

In this mode, the operation of QchannelRcv and associated interrupt QChannelRcvFull is reserved, undefined. Also reserved, undefined is the operation of ChannelLengthError and ChannelSyncFound.

The U-channel is extracted and output by the IEC958 Receive block on EBURcvUChannelStream. Processing is done by the CD-Subcode as described in section [Section 17.4 Processor Interface Overview](#).

17.3.2 IEC958 TRANSMIT INTERFACE

The IEC958 interface provides the necessary features to allow transmitting of digital data according to the IEC958 specification with the exception that only 20-bit data is supported. The 4 LSB's of the 24-bit data word are always '0'. In addition to data, the interface allows for transmission of the C- and U-channels and control over the Valid flag. The transmitter has 2 physical outputs. One with Consumer C-Channel format and one with 'Professional' C-Channel format. On the U-channel, only the CD User Data format is supported.

Note: EBUOUT1 and EBUOUT2 will output a clock signal just after reset and before they can be configured as GPIO. The frequency of the clock output will be CRIN/16.

17.3.2.1 Transmit "C" Channel

There are two IEC958 outputs. The difference is the formatting of the "C" channel. There are also two IEC958 "C" channel control registers, EBU1TxCChannel1 and EBU1TxCChannel2. The following tables show the formatting of both IEC958 outputs.

Table 17-18 EBU1TxChannel Registers Addresses

ADDRESS	NAME	WIDTH	DESCRIPTION	RESET VALUE	ACCESS
MBAR2 + 0x28	EBU1TxChannel1	32	"C" channel bit settings for IEC958 transmitter - Consumer format	Undefined	RW
MBAR2 + 0x2C	EBU1TxChannel2	32	"C" channel bit settings for IEC958 transmitter - Professional format	Undefined	RW

Table 17-19 Formatting of EBUOUT1 (Consumer "C" channel)

IEC958 BITS	FIELD NAME	DESCRIPTION	TAKEN FROM,
0:31	CONTROL	Relevant data	EBU1TXCCHANNEL1(31:0)
32:191			always 0

Note: 1. Ordering of bits in Ebu1TxChannel1 is MSB sent out first. So, Ebu1TxChannel1(31) is sent out as IEC958 bit 0.

Table 17-20 Formatting of EBUOUT2 - Professional "C" Channel

IEC958 BITS	FIELD NAME	DESCRIPTION	TAKEN FROM,
0:23	CONTROL	Relevant data	EBU1TxChannel2(31:8)
24:183			always 0
184:191		CRC using polynomial $x^{**8}+x^{**4}+x^{**3}+x^{**2}+1$	EBU1TxChannel2(7:0)

Note: 1. Ordering of bits in EBU1TxChannel2 is MSB out first. So, EBU1TxChannel2(31) is sent out as IEC958 bit 0.
 Note: 2. IEC958 bits 184:191 are copied from EBU1TxChannel2(7:0). For compliancy to EBU Tech 3250 document, the bits 184:191 should be filled in as the CRC of the complete C-channel frame. This is not done in hardware. A software routine should be used to make sure EBU1TxChannel2(7:0) reflects the correct value.
 Note: 3. The EbuOut2 signal is only used on the 160 MAPBGA package.

17.3.2.2 IEC958 Transmitter Exception Conditions

There are three transmitter exception conditions:

1. Transmit FIFO underrun
2. Transmit FIFO overrun
3. Transmit FIFO empty

17.3.2.3 IEC958-3 Ed2 and Tech 3250-E Standards Compliance

The IEC958 transmitter is compliant with IEC958-3 Ed2 and Tech 3250-E documents from international IEC standards committee and European Broadcasting Union organizations.

The IEC958 transmitter implementation allows any sample frequency. Operation is guaranteed up to a maximum incoming transmit clock of 1/3 of the 48 MHz system clock. The mark/space ratio of the transmit clock must be equal to or better than 38/62.

Freescale Semiconductor, Inc.

Digital Audio Interface (EBU)

17.3.2.4 Transmission of U-Channel and CD Subcode Data

The user channel transmitter is intended to assemble the CD subcode stream, and conform to the IEC958 CD standard specification. The generation of the data needs to be done in software and loaded into hardware registers. The MCF5249 has provisions to insert this CD subcode stream into the outgoing IEC958 stream, or to transmit it over a dedicated 3-wire interface, called the CD-Subcode interface. The 3-wire CD-Subcode is intended to connect Philips Semiconductor CD encoder devices.

This combined interface provides output formats for both CD-Subcode and IEC958 U-channel. The same data is used for both output formats.

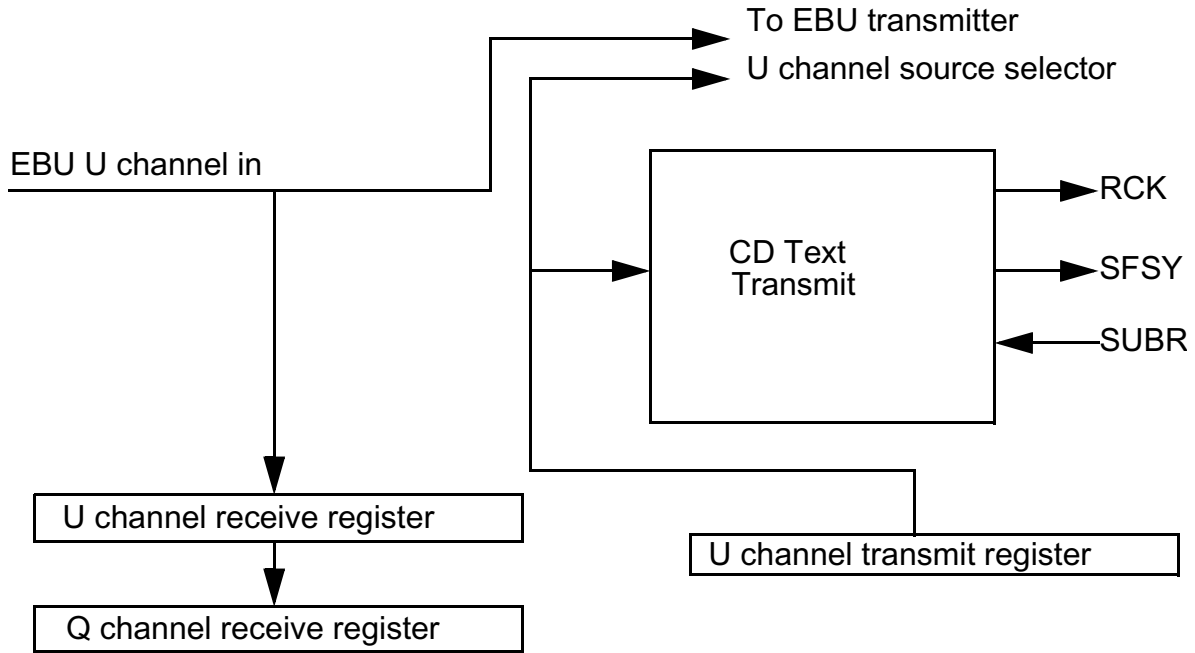

Figure 17-4 CD-Subcode Interface

Table 17-21 UChannel Transmit Register

ADDRESS	NAME	WIDTH	DESCRIPTION	RESET VALUE	ACCESS
MBAR2 BAS + 0x84:0x87	UChannel Transmit	32	U channel transmit register. Contains next 4 U channel bytes.	--	RW

Table 17-22 CD-Subcode Register

BITS	15	14	13	12	11	10	9	8	7	6	5	4	3	2	1	0
FIELD	PRESET EN	PRESETCOUNT(6:0)												USYNC MODE EBU1	USYNC MODE EBU1	UCHAN TXTIM
RESET	0	0	0	0	0	0	0	0	0	0	0	0	0	0	0	0
R/W	R/W															
ADDR	MBAR2 + 0x92															

17.3.3 CD SUBCODE INTERRUPTS

The following interrupts are associated with the CD Subcode data:

- UChannelTxEmpty — Register is empty, needs re-load.
- UChannelTxUnderrun — Underrun error on register.
- UChannelTxNextFirstByte — Received indication from CD-Subcode output interface that next word to be written contains first byte of the 96-byte U-channel frame. CD Subcode Interface: SFSY, RCK and SUBR

Note: The subr, rck, and sfsy signals are only used on the 160 MAPBGA package.

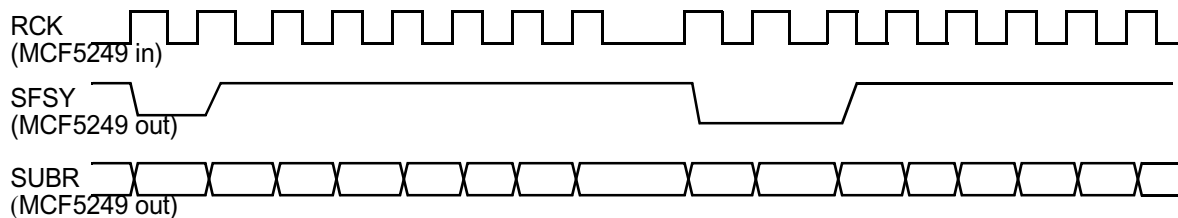

Figure 17-5 Data Format on CD-Subcode Interface Out

RCK is the incoming clock from the channel encoder. SFSY is used to flag the first symbol bit, and first packet symbol. During the first bit of every symbol, SFSY is low, During the first two bits of the first symbol of every packet, SFSY is low.

SUBR is the data out, used to transmit outgoing data in serial form. The most significant bit is transmitted first.

Note: The SUBR, RCK, and SFSY signals are only used on the 160 MAPBGA package.

RCK is an input, SFSY and SUBR are outputs.

CD User channel subcode is transmitted out of the 3-wire CD subcode interface. This user channel subcode needs to be assembled by the ColdFire processor application software.

The CD-Subcode format has a 98-symbol packet structure. Of these 98 packets, the first 2 symbols are sync symbols, followed by 96 8-bit data symbols.

The boundaries of the 98-symbol packets are determined by free-run counters. The first symbol of any packet is transmitted with the special sync sequence on SFSY. The first and second symbols are all-0 symbols. The other 96 symbols need to be uploaded by the application software in register UChannelTransmit.

Upload is done by application software handshaking to interrupt UChannelTxEmpty. If this interrupt is set, the application software uploads 4 symbols of the current user channel packets into register UChannelTx.

The interrupt UChannelTxNextFirstByte flags the start of a new U channel packet. It is always coincident with UChannelTxEmpty, and signal that the first 4 symbols of a new packet need to be loaded into UChannelTx.

The following pseudo-code reacts on both interrupts. One interrupt handler can take care of both UchannelTxEmpty and UChannelTxNextFirstByte. This last interrupt is not enabled.

Freescale Semiconductor, Inc.

Digital Audio Interface (EBU)

```
if(UChannelTxEmpty interrupt) then
  if(UChannelTxNextFirstByt interrupt set also) then
    reset this interrupt
    synchronize pointer to sent out new frame
  end if ;
  load UChannelTransmit with data from pointer
  update pointer
  reset interrupt
end if ;
```

17.3.3.1 Free Running Counter Synchronization

There is a synchronization issue on start-up between the MCF5249 and some channel encoders. On start-up, the RCK clock is kept silent. At a certain point in time, the CDR60¹ will start clocking the RCK, and then it will require that the first symbol transmitted from the MCF5249 to the CDR60 is a sync symbol. If this is not the case, the CDR60 fails to synchronize.

To solve the synchronization issue, the counter that determines the sync position can be preset using the register CdTextControl (see [Table 17-15](#)).

17.3.3.2 Controlling the SFSY Sync Position

When RCK is not clocking, it is possible to control the subcode byte number that will be sent out next by the CD-Subcode interface by writing CdTextControl with PresetEn set '1'.

- When 0 is written to presetCount, the next byte sent out will be a CD-Subcode sync byte. (SFSY low).
- When a value (97 - i) is written to presetCount, i non-sync bytes are transmitted, followed by a sync byte.
- After writing to CdTextControl with PresetEn set to '1', next bit out will always be the first bit of a new byte.
- Writing CdTextControl with PresetEn set to '1', while RCK is running, will result in unpredictable, undefined operation.

17.3.4 INSERTING CD USER CHANNEL DATA INTO IEC958 TRANSMIT DATA

Source selection of data transmitted into the User Channel of IEC958 transmitter is selected by bits (1,0) of register EBUConfig.

- When selected source is IEC958 receiver, every user channel data byte received into the input IEC958 user channel, is inserted into the outgoing stream at approximately the same time it was found in the incoming stream.
- When selected source is CD-Subcode, every data byte transmitted over the CD-Subcode output is also inserted into the IEC958 out stream. The most significant bit of every byte is transmitted as a "1". All sync symbols are transmitted as all-0.
- In case RCK clock is not present, it is still possible to use the CD-Subcode interface to assemble the outgoing IEC958 User channel data. In this case, bit UChanTxTim in register CDText config must be set '1' (see [Table 17-38](#)). It will cause the timing to the CD-Subcode registers to be controlled by the IEC958 transmitter. One symbol (data or sync) will be transmitted into the IEC958 output every 12 User Channel data bits.

1. CDR60 is the informal name for Philips CD-R channel encoder

17.4 PROCESSOR INTERFACE OVERVIEW

The interface between the processor and the Audio Modules is given in this section. Figure 17-6 shows a simplified picture of the interface between the audio modules and the processor core.

Note: The audio module register addresses are relative to the MBAR2 register.

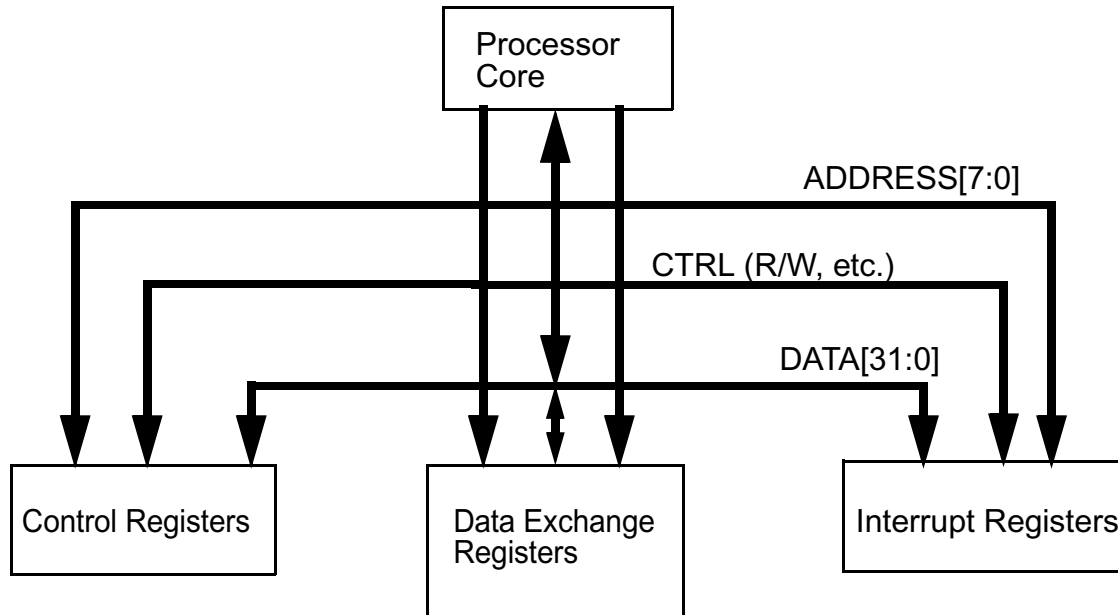

Figure 17-6 Processor/Audio Module Interface

17.4.1 DATA EXCHANGE REGISTER DESCRIPTIONS

Table 17-23 shows the Data Exchange Registers. To read/write data to/from the audio modules use the registers as shown in Table 17-42.

Table 17-23 Data Exchange Register Descriptions

ADDRESS MBAR2 +	NAME	WIDTH	DESCRIPTION	RESET VALUE	ACCESS
0x34 0x38 0x3C 0x40	PDIR1-L	32	Processor data in Left. Multiple address to read this register allows MOVEM instruction to read FIFO.	-	R
0x44 0x48 0x4C 0x50	PDIR3-L	32	Processor data in Left. Multiple address to read this register allows MOVEM instruction to read FIFO.	-	R
0x54 0x58 0x5C 0x60	PDIR1-R	32	Processor data in Right Multiple address to read this register allows MOVEM instruction to read FIFO.	-	R

Table 17-23 Data Exchange Register Descriptions (Continued)

ADDRESS MBAR2 +	NAME	WIDTH	DESCRIPTION	RESET VALUE	ACCESS
0x64 0x68 0x6C 0x70	PDIR3-R	32	Processor data in Right Multiple address to read this register allows MOVEM instruction to read FIFO.	-	R
0x34 0x38 0x3C 0x40	PDOR1-L	32	Processor data out 1 Left. Multiple address to write this register allows MOVEM instruction to write FIFO.	undef	W
0x44 0x48 0x4C 0x50	PDOR1-R	32	Processor data out 1 Right Multiple address to write this register allows MOVEM instruction to write FIFO	undef	W
0x54 0x58 0x5C 0x60	PDOR2-L	32	Processor data out 2 Left Multiple address to write this register allows MOVEM instruction to write FIFO	undef	W
0x64 0x68 0x6C 0x70	PDOR2-R	32	Processor data out 2 Right Multiple address to write this register allows MOVEM instruction to write FIFO	undef	W
0x74 0x78 0x7C 0x80	PDOR3	32	Processor data out 3 left + right	undef	W
0x74 0x78 0x7C 0x80	PDIR2	32	Processor data in 3 left + right	undef	R
<p>Note: 1. Multiple addresses for PDOR/PDIR fields are intended for easy use of MOVEM instruction to move data into and out of the fifo 's. The data read at each address of any range is exactly the same, being the next sample in/out of the fifo. There is no difference in FIFO operation between a read at address e.g. 0x74, 0x78, 0x7C.</p> <p>Note: 2. There is memory overlaps between PDIR's and PDOR's. PDOR's cannot be read, PDIR cannot be written to.</p>					

17.4.2 DATA EXCHANGE REGISTER OVERVIEW

- *PDOR1-L, PDOR1-R*: (Processor Data Out 1). These are 2 32-bit registers. Both registers have 4 consecutive longword addresses assigned (multiple decode). This allows easy transfer of multiple samples using MOVEM instructions. Data written to these registers will end in one of the FIFO 's (Figure 17-1) 12, 14, 17, 17a, 17b or 25. The format of data in the registers is defined below.
- *PDOR2-L, PDOR2-R*: (Processor Data Out 2). Same function as PDOR1. Also double 32-bit registers (PDOR2-L and PDOR2-R), occupying 4 consecutive longword addresses (multiple decoded.) Data written to it will end in one of the FIFO 's. (Figure 17-1) 12,14,17, 17a, 17b or 25.
- *PDOR3*: (Processor Data Out3). Same function as PDOR1. It is a single 32-bit register which contains both Left + Right data in 16-bit precision occupying 4 consecutive longword addresses. Data written to it will end in one of the FIFO 's. (Figure 17-1) 12,14, 17a, 17b or 25.
- *PDIR1-L, PDIR1-R* (Processor data in). Used to transfer data to the processor. These 2 32-bit register, each occupying 4 consecutive longword addresses are used to read data from the audio bus. Data flowing in is selected by source multiplexer 16a. Control via register *DataInControl(12,2:0)*. (Table 17-24).

- *PDIR2* (Processor data in). Same function as *PDIR1*. Single 32-bit register contains both Left + Right in 16-bit precision. Data flowing in is selected by source multiplexer **16**. Control via register *DataInControl(13,5:3)* (Table 17-24)
- *PDIR3-L*, *PDIR3-R* (Processor data in). This function is identical to *PDIR1*. Data flowing in is selected by source multiplexer **16b**. Control via register *DataInControl(19:16)*. (Table 17-24)

17.4.2.1 Data In Selection

The *DataInControl* register determines what data will be in the *PDIR1* input data FIFO, in *PDIR2* input data FIFO, and in the *PDIR3* input data FIFO. All fifo's are six-deep, and have programmable "full" indication.

Table 17-24 DataInControl Register

BITS	31	30	29	28	27	26	25	24	23	22	21	20	19	18	17	16
FIELD									PDIR3 ZERO CTRL	PDIR3 RESET	PDIR3 FULL INTERRUPT	SELECT PDIR3				
RESET	0	0	0	0	0	0	0	0	0	0	0	0	0	0	0	0
R/W	R/W															
BITS	15	14	13	12	11	10	9	8	7	6	5	4	3	2	1	0
FIELD	PDIR2 FULL INTERRUPT SELECT		SELECT PDIR2	SELECT PDIR1	PDIR2 ZERO CTRL	PDIR1 ZERO CTRL	PDIR2 RESET	PDIR1 RESET	PDIR FULL INTERRUPT SELECT	SELECT PDIR2			SELECT PDIR1			
RESET	0	0	0	0	0	0	0	0	0	0	0	0	0	0	0	0
R/W	R/W															
ADDR	MBAR2 + 0X30 (RESET 0X00)															

Note: The *DataInControl* register bits 7:6 allow selection when FIFO full flag is set. This is necessary due to polling. It may be necessary to service the FIFO when it is less than completely full. For *PDIR2*, only interrupt-driven and DMA-driven read-out is supported.

Table 17-25 DataInControl Bit Descriptions

FIELD	FIELD NAME	DESCRIPTION	RESET
23	PDIR3 ZERO CONTROL	0: normal operation 1: Always read zero from <i>PDIR3</i>	0
22	PDIR3 RESET	0: normal operation 1: reset <i>PDIR3</i> to one sample remaining	0
21:20	PDIR3 FULL INTERRUPT SELECT	00: full interrupt if at least 1 sample in fifo 01: full interrupt if at least 2 samples in fifo 10: full interrupt if at least 3 samples in fifo 11: full interrupt if at least 6 samples in fifo	00
19:16	SELECT PDIR3	0000: off 0001: PDOR1 0010: PDOR2 0011: unused 0100: iis1RcvData 0101: iis3RcvData 0110: iis4RcvData 0111: ebu1RcvData 1000: ebu2RcvData	000

Table 17-25 DataInControl Bit Descriptions (Continued)

FIELD	FIELD NAME	DESCRIPTION	RESET
15:14	PDIR2 FULL INTERRUPT SELECT	00: full interrupt if at least 1 sample in fifo 01: full interrupt if at least 2 samples in fifo 10: full interrupt if at least 3 samples in fifo 11: full interrupt if at least 6 samples in fifo	00
11	PDIR2 ZERO CONTROL	0: normal operation 1: Always read zero from PDIR2	0
10	PDIR1 ZERO CONTROL	0: normal operation 1: always read zero from PDIR1	0
9	PDIR2 RESET	0: normal operation 1: reset PDIR2 to one sample remaining	0
8	PDIR1 RESET	0: normal operation 1: reset PDIR1 to one sample remaining	0
7:6	PDIR1 FULL INTERRUPT SELECT	00: full interrupt if at least 1 sample in fifo 01: full interrupt if at least 2 samples in fifo 10: full interrupt if at least 3 samples in fifo 11: full interrupt if at least 6 samples in fifo	00
13,5:3	SELECT PDIR2	0 000: off 0 001: PDOR1 0 010: PDOR2 0 011: unused 0 100: iis1RcvData 0 101: iis3RcvData 0 110: iis4RcvData 0 111: ebu1RcvData 1 000: ebu2RcvData	000
12,2:0	SELECT PDIR1	0 000: off 0 001: PDOR1 0 010: PDOR2 0 011: unused 0 100: iis1RcvData 0 101: iis3RcvData 0 110: iis4RcvData 0 111: ebu1RcvData 1 000: ebu2RcvData	000

17.4.3 PDIR AND PDOR FIELD FORMATTING

Each PDIR, PDOR 32-bit register contains only 20 relevant data bits. Formatting is done as follows:

Table 17-26 PDIR1-L, PDIR3-L, PDOR1-L, PDOR2-L Formatting

BIT 31	BIT 30	BIT 29	BIT 28	BIT 27	BIT 26	BIT 25	BIT 24	BIT 23	BIT 22	BIT 21	BIT 20	BIT 19	BIT 18	BIT 17	BIT 16
~L19	L19	L19	L18	L17	L16	L15	L14	L13	L12	L11	L10	L9	L8	L7	L6
BIT 15	BIT 14	BIT 13	BIT 12	BIT 11	BIT 10	BIT 9	BIT 8	BIT 7	BIT 6	BIT 5	BIT 4	BIT 3	BIT 2	BIT 1	BIT 0
L5	L4	L3	L2	L1	L0	0	0	0	0	0	0	0	0	0	0

Table 17-27 PDIR1-R, PDIR3-R, PDOR1-R, PDOR2-R Formatting

BIT 31	BIT 30	BIT 29	BIT 28	BIT 27	BIT 26	BIT 25	BIT 24	BIT 23	BIT 22	BIT 21	BIT 20	BIT 19	BIT 18	BIT 17	BIT 16
~R19	R19	R19	R18	R17	R16	R15	R14	R13	R12	R11	R10	R9	R8	R7	R6
BIT 15	BIT 14	BIT 13	BIT 12	BIT 11	BIT 10	BIT 9	BIT 8	BIT 7	BIT 6	BIT 5	BIT 4	BIT 3	BIT 2	BIT 1	BIT 0
R5	R4	R3	R2	R1	R0	0	0	0	0	0	0	0	0	0	0

Table 17-28 PDIR2, PDOR3 Formatting

BIT 31	BIT 30	BIT 29	BIT 28	BIT 27	BIT 26	BIT 25	BIT 24	BIT 23	BIT 22	BIT 21	BIT 20	BIT 19	BIT 18	BIT 17	BIT 16
L19	L18	L17	L16	L15	L14	L13	L12	L11	L10	L9	L8	L7	L6	L5	L4
BIT 15	BIT 14	BIT 13	BIT 12	BIT 11	BIT 10	BIT 9	BIT 8	BIT 7	BIT 6	BIT 5	BIT 4	BIT 3	BIT 2	BIT 1	BIT 0
R19	R18	R17	R16	R15	R14	R13	R12	R11	R10	R9	R8	R7	R6	R5	R4

- Note: 1. L18 is bit 18 of left sample, ~L19 is inverse of bit 19 of left sample, R18 is bit 18 of right sample.
 Note: 2. If incoming/outgoing interface use 16, 18 bits, data is aligned at the MSB side. LSB 's D1-D0 or D3-D0 will read all-zero. Written values are disregarded.
 Note: 3. PDOR3, PDIR2 use only 16 MSB of both left and right.
 Note: 4. Inversion of MSB 's L19 and R19 translates the format from 2-complement to unsigned.
 (The continuous range e.g. -0x8000 to +7FFF is translated to 0 to +0xFFFF)

17.4.4 OVERRUN AND UNDERRUN WITH PDIR AND PDOR REGISTERS

All PDOR and PDIR registers have different FIFOs for left and right channel. As a result, there is always the possibility that left and right FIFOs may go out of sync due to fifo underruns and fifo overruns that affect only one part (left or right) of any fifo. To prevent this from happening, two hardware mechanisms are available:

1. If PDIR1, PDIR2, or PDIR3 fifo overrun occurs on, as an example, the right half of the FIFO, the sample that caused the overrun is not written to the right half (due to overrun). Special hardware will make sure the next sample is not written to the left half of the FIFO. If the overrun occurs on the left half of the fifo, the next sample is not written to the right half of the FIFO.
2. If IIS1 or IIS2 Tx fifo, or EBU Tx fifo underruns on, for example, the right half of the FIFO, no sample leaves that fifo. (because it was already empty.) Special hardware ensures that the next sample read from the left fifo will not leave the fifo. (No read strobe is generated). If the underrun occurs on the left half of the FIFO, next read strobe to the right fifo is blocked.

17.4.5 AUTOMATIC RESYNCHRONIZATION OF FIFOS

An automatic FIFO resynchronization feature is available on the MCF5249. It can be enabled and disabled separately for every FIFO. If enabled, the hardware will check if the left and right FIFOs are in sync, and if not, it will set the filling pointer of the right fifo to be equal to the filling pointer of the left fifo.

The operation is shown in Figure 17-7. Every FIFO auto-resync controller has a state machine with three states:

1. Off
2. Stand-By
3. On

In the On state, the filling of the left fifo is compared with the filling of right, and if they are not equal, right is made equal to left, and an interrupt is generated.

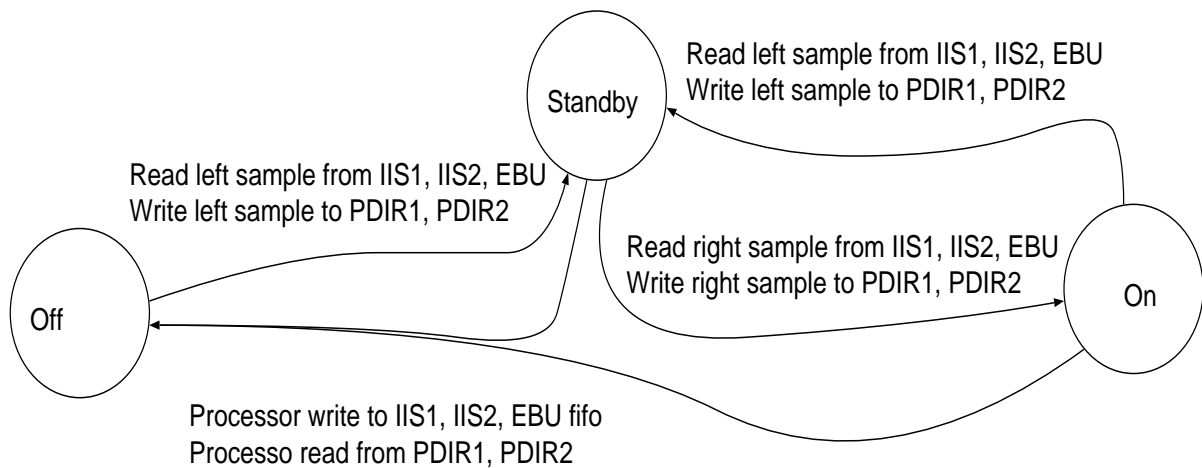

Figure 17-7 Automatic Resynchronization FSM of left-right FIFOs

The controller will stay in off state when the feature is disabled. When not disabled, the state machine will go to the off state on any processor read or write to the FIFO. It will go from On or Off to Standby on any left sample read from IIS, IIS2, and EBU Tx fifos, or on any left sample write to PDIR1, PDIR2, PDIR3 fifos. The controller will go from Standby to On on any right sample read from IIS1, IIS2 and EBU Tx fifos, or on any right sample write to PDIR1, PDIR2 and PDIR3.

Table 17-29 audioGlob Register

BITS	15	14	13	12	11	10	9	8	7	6	5	4	3	2	1	0
FIELD				PDIR3 FIFO AUTO SYNC	AUDIOTICK SOURCE EBU2 EXT	EBU1 TX AUTO SYNC	IIS2 FIFO AUTO SYNC		PDIR2 FIFO AUTO SYNC	PDIR1 FIFO AUTO SYNC	AUDIO_TICK COUNT			AUDIOTICK SOURCE		
RESET	0	0	0	0	0	0	0	0	0	0	0	0	0	0	0	0
R/W	R/ W	R/ W	R/ W	R/W	R/W	R/W	R/W	R/W	R/W	R/W	R/ W	R/ W	R/ W	R/ W	R/ W	R/ W
ADDR	0XCC															

Table 17-30 audioGlob Register Fields (0xCE)

FIELD - BITS	NAME	DESCRIPTION	RESET	NOTES
12	PDIR3 FIFO AUTO SYNC	0: auto synchronization off 1: auto synchronization on	0	
10	EBU TX AUTO SYNC	0: auto synchronization off 1: auto synchronization on	0	
9	IIS2 FIFO AUTO SYNC	0: auto synchronization off 1: auto synchronization on	0	
8	IIS1 FIFO AUTO SYNC	0: auto synchronization off 1: auto synchronization on	0	
7	PDIR2 FIFO AUTO SYNC	0: auto synchronization off 1: auto synchronization on	0	
6	PDIR1 FIFO AUTO SYNC	0: auto synchronization off 1: auto synchronization on	0	
5:3	AUDIO TICK COUNT	000: 1. Interrupt for every event 001: 2 Interrupt for every 2 events 010: 3 011: 4 100: 5 Other: reserved, unused	000	
11, 2:0	AUDIO TICK SOURCE	0 000: off 0 001: IIS1 Tx Right fifo / Read 0 010: IIS2 Tx Right fifo / Read 0 011: EBU Tx Right fifo / Read 0 100: IIS1 Rcv Data 0 101: IIS3 Rcv Data 0 110: IIS4 Rcv Data 0 111: EBU1 Rcv Data 1 000: EBU2 Rcv Data	000	
<p>Note: The automatic FIFO resynchronization can be switched on, and will avoid all mismatch between left and right fifo 's, if the software obeys following rules:</p> <ol style="list-style-type: none"> When left data is read or written to the left FIFO, in the same place of the program, data must be read or written to the right fifo. Maximum time difference between left and right is 1/2 sample clock. (E.g. if sample frequency is 44 Khz, approximately 10 micro-seconds. For 88 Khz, approximately 5 micro-seconds.) Write/read data to FIFO 's at least 2 samples at the time. If there is a mis-match Left-Right, the resync logic may go on only 1 sample clock after last data is read/written to the FIFO. Also acceptable is polling the fifo, if at least part of the time 2 samples will be read/written to it. 				

17.4.6 AUDIO INTERRUPTS

17.4.6.1 AudioTick Interrupts

The audio tick interrupt is an interrupt to sustain an interrupt routine that is synchronous with one of the audio interfaces, but not directly related to any FIFO being full or empty. Two fields control how this interrupt is generated:

1. The source field controls the source event.
2. The count field controls the number of events (sample pairs) between any two audioTick interrupts.

For example, if the source is set to IIS1 Tx fifo / Read, and count is set to three, the interrupt will pulse after every three read strobes to the IIS1 Tx fifo. Even if the fifo is in reset state, the interrupt will continue running.

17.4.6.2 PDIR1, PDIR2, and PDIR3, Exceptions

With FIFOs feeding data to PDIR registers, three exceptions are associated.

1. Full
2. Under/over
3. Resync

When the Full condition is set for processor data input registers, the MCF5249 processor should read data from the FIFO, before overrun occurs (this is within 1/2 sample period). Reading of data should be done using 32-bit operands (ex. MOVE.L instruction). When Full is set, and the FIFO contains, for example six samples, it is acceptable for the software to read the first six samples from the LEFT address, followed by six samples from the RIGHT address, or six samples from the RIGHT address, followed by six samples from the LEFT address, or one sample LEFT, followed by one sample RIGHT repeated six times. There is no order specified.

The implementation for PDIR1 is a double FIFO, one for left and one for right. The Full condition is set when both FIFOs are full. The Underrun/Overrun condition is set when one of the FIFOs actually underrun or overrun. The resync interrupt is set when the hardware took special action to resynchronize left and right FIFOs.

17.4.6.3 PDOR1, PDOR2, and PDOR3 Exceptions

Three exceptions are associated with FIFOs that can be written from PDOR1, PDOR2, PDOR3:

1. Empty
2. Under/over
3. Resync

When the Empty condition is set for processor data output registers, the ColdFire processor should write data to the FIFO, before underrun occurs. Writing of data should be done using MOVE LONG or MOVEM instructions, in any case with long-word oriented instructions. When Empty is set, and, for example, six samples need to be written, it is acceptable for the software to write first six samples from the LEFT address, followed by six samples from the RIGHT address, or one sample LEFT, followed by one sample RIGHT repeated six times.

Note: The left should be written before the right.

The implementation of all data out FIFOs is a double FIFO, one for left and one for right. The Empty exception is set when both FIFOs are empty. The Underrun/Overrun exception is set when one of the FIFOs is underrun or is overrun. Resync is set when the hardware resynchronizes left and right FIFOs.

On receiving an Underrun/Overrun interrupt, synchronization between Left and Right words in the FIFOs may be lost. Synchronization will not be lost when the underrun or overrun comes from the audio side of the FIFO. If the processor reads or writes more data from, for example, the left than from the right, synchronization will be lost. If automatic resynchronization is enabled, and if the software obeys the rules to let this work, resynchronization will be automatic.

Table 17-31 Interrupt Register Description (0x94, 0x98)

BIT	INTERRUPT NAME	DESCRIPTION	HOW TO CLEAR
31	iis1TxUnOv	iis1 transmit fifo under/overrun	reg. IntClear
30	iis1TxResyn	iis1 transmit fifo resync	reg. IntClear
29	iis2TxUnOv	iis2 transmit fifo under/overrun	reg. IntClear
28	iis2TxResyn	iis2 transmit fifo underrun	reg. IntClear
27	ebuTxUnOv	IEC958 transmit fifo under/overrun	reg. IntClear
26	ebuTxResyn	IEC958 transmit fifo resync	reg. IntClear
25	ebuCNew	IEC958 receiver change in value of Control channel	reg. IntClear
24	lec958ValNoGood	IEC958 validity flag no good	reg. IntClear
23	ebuSymErr	IEC958 receiver found illegal symbol	reg. IntClear
22	ebuBitErr	IEC958 receiver found parity bit error	reg. IntClear
21	UChanTxEm	<i>UChannelTransmit</i> register empty	write to tx reg
20	UChanTxUnder	<i>UchannelTransmit</i> register underrun	reg. IntClear
19	UChanTx-NextFirst	<i>UchannelTransmit</i> register next byte will be first	write to Tx reg
18	UChanRcvFull	<i>UChannelReceive</i> register full	read Rcv reg
17	UChanRcvOver	<i>UChannelReceive</i> register overrun	reg. IntClear
16	QChanRvFull	<i>QChannelReceive</i> register full	read rcv reg
15	QChanOverrun	<i>QChannelReceive</i> register overrun	reg. IntClear
14	UQChanSync	U/Q channel sync found	reg. IntClear
13	UQChanErr	U/Q channel framing error	reg IntClear
12	Pdir1UnOv	Processor data input underrun/overrun	reg IntClear
11	Pdir1Resyn	Processor data input resync	reg IntClear
10	Pdir2UnOv	Processor data input underrun/overrun	reg IntClear
9	Pdir2Resyn	Processor data input resync	reg IntClear
8	audioTick	audio tick interrupt	reg IntClear
7			
6			
5			

Table 17-31 Interrupt Register Description (0x94, 0x98) (Continued)

BIT	INTERRUPT NAME	DESCRIPTION	HOW TO CLEAR
4	iis1TxEmpty	IIS 1 transmit fifo empty	write to FIFO
3	iis2TxEmpty	IIS 2 transmit fifo empty	write to FIFO
2	ebuTxEmpty	IEC958 transmit fifo empty	write to FIFO
1	PDIR2 full	Processor data input full	read from PDIR2
0	PDIR1 full	Processor data input full	read from PDIR1

17.4.6.4 Audio Interrupt Routines and Timing

Usually, the MCF5249 processor will run an audio interrupt routine. Every time the audio interrupt routine runs, it will process 2, 3, or 4 audio samples, and send this many samples to one or more PDOR output registers. Also, the audio interrupt routine will read one or more PDIR registers until empty.

In the audio interrupt routine, typically at the beginning, the PDIR registers are read until empty, while the PDOR registers are written at the end of the routine when all calculations are completed. Due to this calculation latency, there is a delay between entering the audio interrupt routine and the filling of the transmit FIFOs.

Due to this delay, it is difficult to “fire” the audio interrupt routine on a transmit FIFO empty interrupt. Because of the extra delay before the data is written, the transmit fifo will underrun before any data is written.

To make it easy for the programmer, the audioTick interrupt was added. To start the audio interrupt routine, use the following sequence:

1. Reset the transmit FIFOs
2. Program the transmit FIFOs to correct source, de-assert reset on transmit FIFOs
3. Reset the PDIR FIFOs
4. Load audio interrupt routine in on-chip SRAM
5. Release reset for the PDIR FIFOs and enable audioTick interrupt

The transmit FIFOs have a special feature. After the software releases the reset to them, they will stay in reset until the audio Interrupt Routine writes data to them for the first time. So, during Step 2 of above mentioned start-up procedure, all transmit data out FIFOs are set in reset, with one sample remaining. They will stay in this state, until the audio Interrupt Routine writes data to them. At this point in time, they are then filled up with extra 2,3, or 4 samples to a total of 3,4, or 5 samples. Also, the first data write to the FIFOs releases the reset, and starts transmission of FIFO data on the corresponding transmit output. (IIS1, IIS2 or IEC958). The next time that data is written to the FIFOs in the audioTick interrupt routine, 2,3, or 4 samples have been transmitted and the FIFO is ready to accept new data.

To work properly, the jitter from one audioTick write point to the next is important. Jitter should be lower than 1 sample period if data is written in groups of 2 or 3 samples to the transmit FIFOs, and lower than 1/2 sample period if data is written in groups of 4 samples to the transmit FIFOs.

The receive FIFOs (PDIR) don't have an auto-reset-de-assert mechanism, and should be released out of reset just before enabling audioTick interrupt.

Figure 17-8 shows the timing (relative to the Word Clock) of the Empty, Under-run, and Audio Tick interrupts. Each FIFO holds up to six audio samples (left and right).

The Empty Interrupt occurs when there is still one right sample left to be transmitted, thus giving the system one audio sample length to fill the FIFO back-up. The Under-run Interrupt occurs when there are no samples left to be transmitted. While this is a situation that should be taken seriously, it will rarely occur. However, should this happen, the system will continue to repeat the last sample until the FIFO buffer has new data.

The Audio Tick Interrupt was introduced to aid a busy system by allowing the Interrupt to occur after a number of (programmable) sample pairs. In this example, the Audio Tick Interrupt has been set to trigger after the 4th sample pair. This gives the system up to two audio sample pairs to respond and fill the FIFO. This avoids the under-run issue. The decision to use the Audio Tick interrupt as apposed to the Empty Interrupt is dependent on the system and the reaction time of that system. Therefore, it is not expected that the Audio Tick Interrupt need to be employed in all systems.

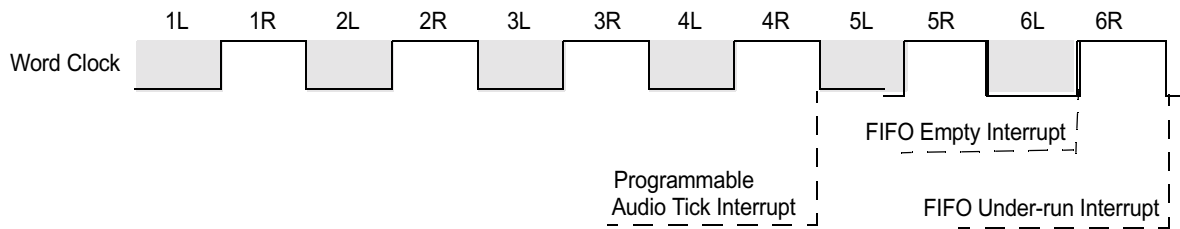

Figure 17-8 Audio Transmit / Receive FIFOs

17.4.7 CD-ROM BLOCK ENCODER AND DECODER

The processor interface registers PDOR3 and PDIR2 are equipped with a CD-ROM block encoder/decoder. The two interfaces are fully independent. One control register is associated with the interface.

Table 17-32 blockControl Register

BITS	15	14	13	12	11	10	9	8	7	6	5	4	3	2	1	0
FIELD	DECODE SWAP		DECODE SYNC ALLOW		DECODE DE-SCRAMBLE		DECODE MODE		ENCODE SWAP		ENCODE SYNC ALLOW		ENCODE SCRAMBLE		ENCODE MODE	
RE-SET	0	0	0	0	0	0	0	0	0	0	0	0	0	0	0	0
R/W	R/W															
ADDR	MBAR2 BAS+ 0xC8															

Table 17-33 blockControl Bit Descriptions

BIT NUMBER	BIT NAME	DESCRIPTION	RESET	NOTES
14,15	DECODE SWAP	See note 1. Block decode swap control.(00	1
13	DECODE-SYNC ENABLE	See note 2. 1 = Sync detection enabled. 0 = Sync detection disabled	0	2
11	DECODE ENABLE	See note 3. 1 = descramble enabled. 0 = escramble disabled	0	3
9, 10	DECODE MODE	See note 4. 00: No CRC check 01: Mode 1 10: Mode 2, form 1 11: Mode 2, form 2	00	4
6, 7	ENCODE SWAP	See note 1. Block encode swap control	00	1
5	ENCODE SYNC ENABLE	See note 2. 1 = Outgoing sync detecting enabled. 0 = Outgoing sync detecting disabled	0	2
3	ENCODE ENABLE	See note 3. 1 = scramble active 0 = scrambling inactive	0	3
1, 2	ENCODE MODE	00: No CRC instructed 01: Mode 1 10: mode 2, form 1 11: mode 2, form 2	00	4, 5
<p>Note: 1. See Table 17-34 for definition of how swap is done.</p> <p>Note: 2. Decode Sync Allow and Encode Sync Allow define whether the interfaces recognize the CD-ROM syncs embedded in the CD-ROM sectors. If this bit is switched on, then the interface will recognize the start of a new sector after finding the sync sequence in the data. If the bit is switched off, or if no sync sequence is found, sector start is assumed to be one sector length (2352 bytes) after the previous sector.</p> <p>Note: 3. Descrambling/scrambling control if CD-ROM descrambling/scrambling is done.</p> <p>Note: 4. Mode selection determines how CRC is calculated. The CRC depends on CD-ROM mode/form, as defined in CD standards.</p> <p>Note: 5. inserted CRC will over-write processor written data. (Processor sets CRC to any value, logic overwrites this.)</p>				

Table 17-34 Swap Control in CD-ROM Encoder/Decoder

SWAP FIELD	SWAP ACTION
00	dataOut(31:0):= dataIn(31:0)
01	dataOut(31:16):= dataIn(15:0) dataOut(15:0):= dataIn(31:16)
10	dataOut(31:24):= dataIn(23:16) dataOut(23:16):= dataIn(31:24) dataOut(15:8):= dataIn(7:0) dataOut(7:0):= dataIn(15:8)
11	dataOut(31:24):= dataIn(7:0) dataOut(23:16):= dataIn(15:8) dataOut(15:8):= dataIn(23:16) dataOut(7:0):= dataIn(31:24)

Note: 1. Notation used is 32-bit words. Bits31-16 are part of the LEFT sample, bits 15-0 are part of the RIGHT sample.

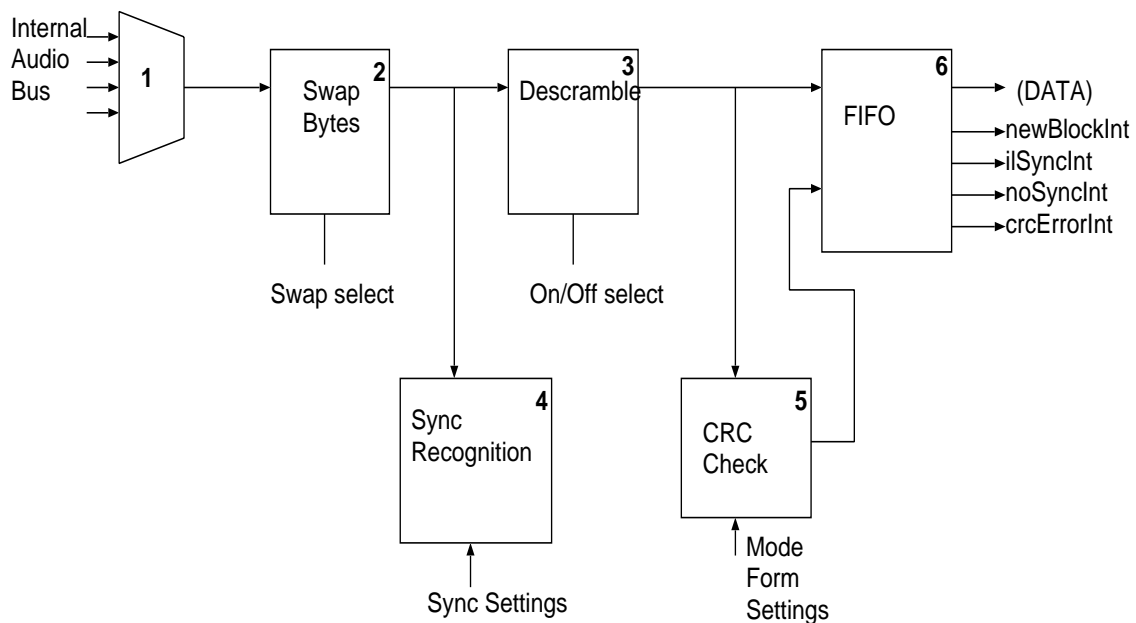

Figure 17-9 Block Decoder

17.4.7.1 CD-ROM Decoder Interrupts

The block decoder can detect and signal sync patterns and error conditions. The following conditions are flagged in status bits and each of these can generate an interrupt. All interrupts occur when the corresponding data word reaches the output of the FIFO.

- newBlock interrupt — Set when the next longword to be read is first word of new block.
- noSync interrupt — Set when the next longword to be read is first word of new block, and no valid sync pattern was found before the start of this new block in the stream.

DMA Channel Interaction

- iISync interrupt — Set when the next longword to be read is first word of new block, and length of previous block was not equal to 2352 bytes, the nominal block length.
- crcError interrupt — Set when the next longword to be read is first word of new block, and CRC check on previous block failed.

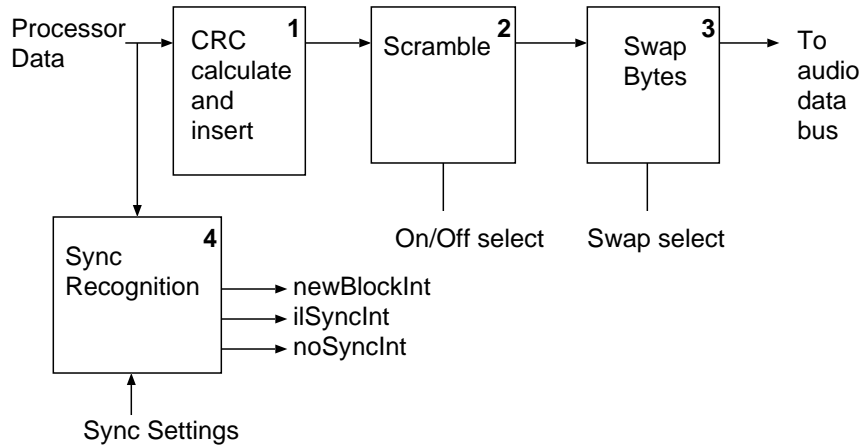

Figure 17-10 Block Encoder

The block encoder works on the incoming PDOR3 stream. First, CRC insertion is done in the CRC Calculate and Insert (1), next the stream is scrambled in Scramble (2), and finally it is byte-swapped in Byte Swaps (3). All three operations can be configured by writing to the *blockControl* register. CRC insertion and scrambling are done as described in CD Yellow Book.

The CRC insertion 1 and the scrambling 2 are done on a block-by-block basis. A block is normally 2352 bytes long. A block starts after the so-called *sync Pattern*, "00FFFFFF-FFFFFFF-FFFFFF00". To detect start of a new block, two mechanisms are build into the encoder.

- First long-word of new block is assumed after finding the sync pattern "00FFFFFF-FFFFFFF-FFFFFF00"
- First long-word of new block is assumed exactly 2352 bytes after first longword of previous block. This second detection mechanism builds in immunity for corrupted syncs. Even if the sync is corrupted, the block encoder will correctly find the start of the new block.

17.4.7.2 CD-ROM Encoder Interrupts

- newBlock interrupt — Active when transmission of new block is started. No direct synchronization with data written to the transmit fifo.
- noSync interrupt — Set when the sync pattern was not recognized for the current newBlock interrupt.
- iISync interrupt — Set when the previous block did not have the correct length. (Length different from 2352 bytes).

17.5 DMA CHANNEL INTERACTION

It is possible to use DMA to transfer data to/from the FIFOs in the audio interface module. Only PDIR2 and PDOR3 registers support DMA, as others need more than 1 long-word to transfer data to/from the FIFO and cannot be used with DMA operation.

Operation is as follows:

- If PDIR2 is full and DMAConfig(1) is set to '0', Dma1Req is activated.
- If PDIR2 is full and DMAConfig(0) is set to '0', DMA0req is activated.
- If the FIFO connected to PDOR3 is empty, and DMAConfig(1) is set '1', Dma1Req is activated.
- If the FIFO connected to PDOR3 is empty, and DMAConfig(0) is set to '1', DMA0req is activated.

Both DMA1req and DMA0req can be routed to DMA channel 0 or DMA channel 1. For details, see description of ColdFire DMA controller.

Table 17-35 DMA Config Register Address

BITS	7	6	5	4	3	2	1	0
FIELD							DMA1REQ	DMA0REQ
RESET							0	0
R/W							R/W	R/W
ADDR	MBAR2 + 0X9F							

Table 17-36 DMA Config Bit Descriptions

BIT NAME	DESCRIPTION	NOTES
DMA1REQ	0 = PDIR2 1 = PDOR3	1, 2, 3
DMA0REQ	0 = PDIR2 1 = PDOR3	1, 2, 3

17.6 PHASE/FREQUENCY DETERMINATION AND XTRIM FUNCTION

These features are necessary so that users can determine when a software sample rate convertor should be enabled and provide the necessary control to steer the sample rate convertor clock (when the incoming sample rate is other than 44.1 Khz).

In addition, users can also utilize this function to determine when the incoming IEC958 clock does not match the phase of the Xtal oscillator and use the XTRIM function to trim the external oscillator to match (within a 150ppm range). Typically, when the IEC958 input is being used, the xtal requires trimming to match but this is only when the source is completely external to the application.

When the source is internal to the application, such as from a CD player controlled by the MCF5249, then the input sample rate does not need to match the output sample rate, so they can be asynchronous. When FIFO under-run or over-run occurs, request that the data lost is re-read by the system.

17.6.1 INCOMING SOURCE FREQUENCY MEASUREMENT

The PLL maintaining phase relation between incoming source signal and internal signal is mainly digital. It is necessary, however, to measure phase/frequency of the incoming signal in relationship with the crystal

Freescale Semiconductor, Inc.

Phase/Frequency Determination and Xtrim Function

clock in order to be able to steer the sample rate convertor clock. The circuit shown in Figure 17-11 is used for maintaining phase relationship.

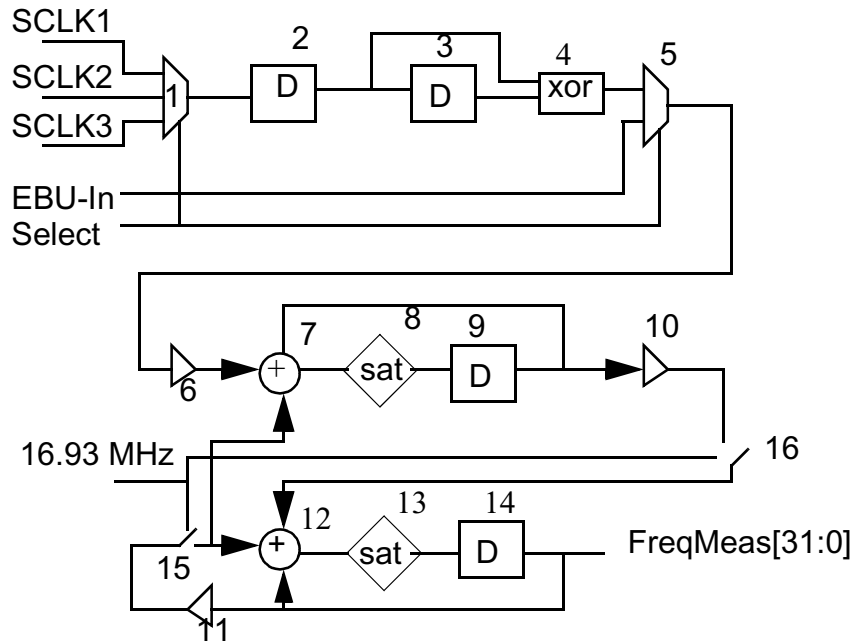

Figure 17-11 Frequency Measurement Circuit

Associated with it, are two registers. (See Table 17-37). The circuit will measure the frequency of the incoming clock by comparison with the audio X-tal clock (typically 16.93 MHz). Multiplexer (1) selects the incoming clock source. Registers (2),(3), and xor (4) are an edge detector. Multiplexer (5) is a by-pass for the IEC958 input. The rest of the circuit is a second-order filter with a bandwidth of approximately 80 Hz. The output FreqMeas(31:0) is an unsigned number, giving the frequency of the selected source in function of the X-tal clock. The filter is calculated internally in 48 bit precision. The 16 LSBs are not sent out.

The value read from the FreqMeas Register is calculates as follows:

- For measurement on IIS: $\text{FreqMeas} = (\text{IIS SCLK Freq} * 2) / \text{Faudio} * (2^{**} 15) * \text{Gain}$
- For measurement on EBU: $\text{FreqMeas} = (\text{EBU freq}) / \text{Faudio} * (2^{**} 15) * \text{Gain}$

Table 17-37 PhaseConfig and Frequency Measure Register Addresses

ADDRESS	NAME	WIDTH	DESCRIPTION	RESET VALUE	ACCESS
MBAR2 + BAS 0xA8:0xAB	FreqMeas	32	Frequency measurement		R

Table 17-38 PhaseConfig Register

BITS	7	6	5	4	3	2	1	0
FIELD			GAIN SELECT			SOURCE SELECT		
RESET			0	0	0	0	0	0
R/W	R/W	R/W	R/W	R/W	R/W	R/W	R/W	R/W
ADDR	MBAR2 + 0XA3							

Table 17-39 PhaseConfig Bit Descriptions

BIT NAME	DESCRIPTION
GAIN SELECT	000: 6 * 2 ** 15 001: 4 * 2 ** 15 010: 3 * 2 ** 15 011: 4 * 2 ** 14 100: 3 * 2 ** 14 101: 4 * 2 ** 13 110: 3 * 2 ** 13
SOURCE SELECT	000: SCLK1 001: SCLK2 010: SCLK3 011: SCLK4 100: EBUIN others: Reserved, undefined

Table 17-40 PhaseConfig Register Description (0xA0)

FIELD	FIELD NAME	DESCRIPTION	RESET
5:3	GAIN SELECT	000: 6 * 2 ** 15 001: 4 * 2 ** 15 010: 3 * 2 ** 15 011: 4 * 2 ** 14 100: 3 * 2 ** 14 101: 4 * 2 ** 13 110: 3 * 2 ** 13	000
2:0	SOURCE SELECT	000: SCLK1 001: SCLK2 010: SCLK3 011: SCLK4 100: EBUIN others: Reserved, undefined	000

Freescale Semiconductor, Inc.

Phase/Frequency Determination and Xtrim Function

17.6.1.1 Filtering for the Discrete Time Oscillator

The frequency measurement circuit first detects the edges of the incoming clock. This pulse signal is then passed through an 80 Hz band-width low-pass filter. The signal that comes after the low-pass filter is low-noise, and is suitable for precision frequency measurement. (Expected noise level: order-of magnitude -100 dB). Before it can be used as a frequency increment for the Discrete Time oscillator, it must undergo additional filtering to push back the noise level on the phase.

17.6.2 XTRIM OPTION - LOCKING XTAL CLOCK TO INCOMING SIGNAL

The XTRIM output allows use of varicap-controlled crystal. (See [Figure 17-12](#)). To do this, the Xtrim must output a PWM/PDM modulated phase-error signal. One 16-bit config register is associated with this functionality.

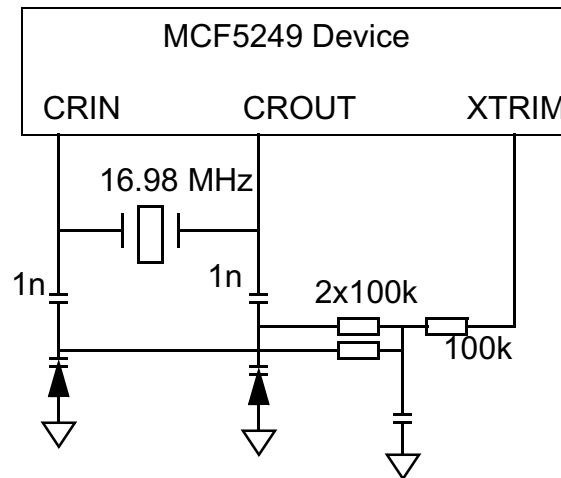

Figure 17-12 XTRIM External Circuit

Table 17-41 XTrim Register Address and Description

ADDRESS	NAME	WIDTH	DESCRIPTION	RESET VALUE	ACCESS
MBAR2 + BAS 0xA6:0xA7	Xtrim	16	XTRIM output value	0x8000	RW

The duty cycle output on Xtrim is proportional to the value written to register Xtrim. 0x0000 corresponds with duty cycle 0, 0xFFFF corresponds with 100%. 0x8000 corresponds with 50%.

17.6.3 XTRIM INTERNAL LOGIC

For XTRIM, the internal circuit of the PDM modulator is used as shown in [Figure 17-13](#). It is a first-order pulse density modulator, working from the system clock divided by 16.

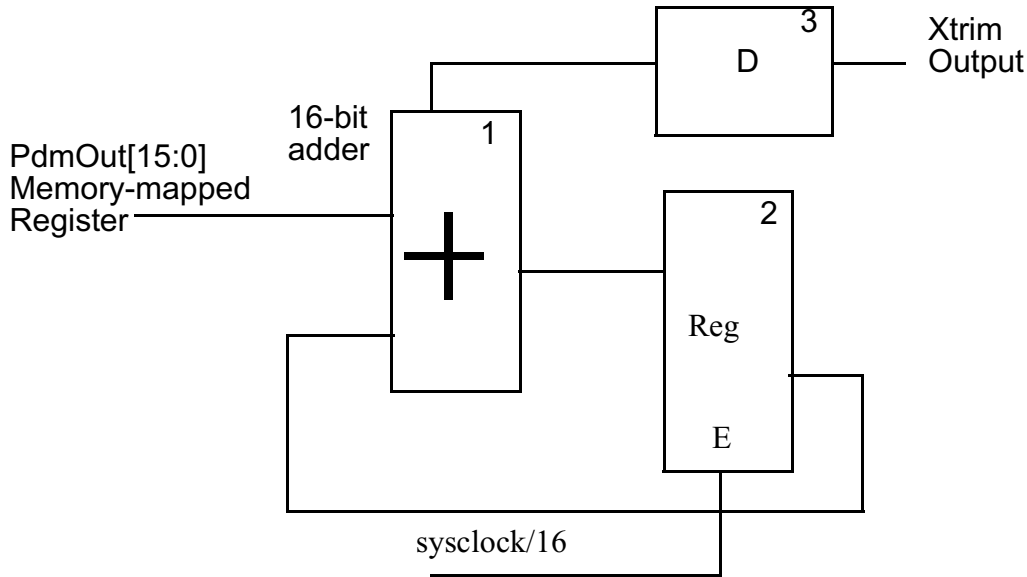

Figure 17-13 PDM Modulator Used on Xtrim Output

17.7 AUDIO INTERFACE MEMORY MAP

All of the Audio Interface registers listed in the following table have already been shown in the various parts of this section. They are repeated here as a quick reference.

Table 17-42 Audio Interface Memory Map

ADDRESS	ACCESS	SIZE BITS	NAME	DESCRIPTION
MBAR2 + 0x12	RW	32	IIS1config	Config register for IIS interface 1
MBAR2 + 0x16	RW	32	IIS2config	Config register for IIS interface 2
MBAR2 + 0x1A	RW	32	IIS3config	Config register for IIS interface 3
MBAR2 + 0x1E	RW	32	IIS4config	Config register for IIS interface 4
MBAR2 + 0x20	RW	32	EBU1config	Config register for EBU 1 interface
MBAR2 + 0x20	RW	32	EBU2config	Config register for EBU 2 interface
MBAR2 + 0x24:0x27	R	32	EBU1RcvCChannel	Control channel 1 as received by EBU interface - first 32 bits
MBAR2 + 0xD0:0xD3	R	32	EBU2RcvCChannel	Control channel 2 as received by EBU interface - first 32 bits
MBAR2 + 0x28:0x2B	RW	32	EBU1TxCChannel	"C" channel bits for EBU transmitter - Consumer format
MBAR2 + 0x2C:0x2F	RW	32	EBU2TxCChannel	"C" channel bits fro EBU transmitter - professional format
MBAR2 + 0x32	RW	16	DataInControl	PDIR source select

Table 17-42 Audio Interface Memory Map (Continued)

ADDRESS	ACCESS	SIZE BITS	NAME	DESCRIPTION
MBAR2 BAS + 0x34:0x37 MBAR2 BAS + 0x38:0x3B MBAR2 BAS + 0x3C:0x3F MBAR2 BAS + 0x40:0x43	R	32	PDIR1-L	Processor data in - Left Multiple read addresses allow MOVEM instruction to read FIFO
MBAR2 BAS + 0x44:0x47 MBAR2 BAS + 0x48:0x4B MBAR2 BAS + 0x4C:0x4F MBAR2 BAS + 0x50:0x53	R	32	PDIR3-L	Processor data in - Left Multiple read addresses allow MOVEM instruction to read FIFO
MBAR2 BAS + 0x54:0x57 MBAR2 BAS + 0x58:0x5B MBAR2 BAS + 0x5C:0x5F MBAR2 BAS + 0x60:0x63	R	32	PDIR1-R	Processor data in - Right
MBAR2 BAS + 0x64:0x67 MBAR2 BAS + 0x68:0x6B MBAR2 BAS + 0x6C:0x6F MBAR2 BAS + 0x70:0x73			PDIR3-R	Processor data in - Right
MBAR2 BAS + 0x34:0x37 MBAR2 BAS + 0x38:0x3B MBAR2 BAS + 0x3C:0x3F MBAR2 BAS + 0x40:0x43	W	32	PDOR1-L	Processor data out 1 - Left
MBAR2 BAS + 0x44:0x47 MBAR2 BAS + 0x48:0x4B MBAR2 BAS + 0x4C:0x4F MBAR2 BAS + 0x50:0x53	W	32	PDOR1-R	Processor data out 1 - Right
MBAR2 BAS + 0x54:0x57 MBAR2 BAS + 0x58:0x5B MBAR2 BAS + 0x5C:0x5F MBAR2 BAS + 0x60:0x63	W	32	PDOR2-L	Processor data out 2 - Left
MBAR2 BAS + 0x64:0x67 MBAR2 BAS + 0x68:0x6B MBAR2 BAS + 0x6C:0x6F MBAR2 BAS + 0x70:0x73	W	32	PDOR2-R	Processor data out 2 - Right
MBAR2 BAS + 0x74:0x77 MBAR2 BAS + 0x78:0x7B MBAR2 BAS + 0x7C:0x7F MBAR2 BAS + 0x80:0x83	W	32	PDOR3	Processor data out 3 left + right
MBAR2 BAS + 0x74:0x77 MBAR2 BAS + 0x78:0x7B MBAR2 BAS + 0x7C:0x7F MBAR2 BAS + 0x80:0x83	R	32	PDIR2	Processor data in 2 left + right
MBAR2 BAS + 0x84:0x87	RW	32	UChannelTransmit	U channel transmit register
MBAR2 + 0x88	R	32	UChannelReceive	U channel receive register
MBAR2 + 0x8C	R	32	QChannelReceive	Q channel receive register
MBAR2 BAS + 0x92:0x93	RW	16	CDTextControl	CD text configuration register
MBAR2 + 0x9F	RW	8	DmaConfig	Configure DMA

Table 17-42 Audio Interface Memory Map (Continued)

ADDRESS	ACCESS	SIZE BITS	NAME	DESCRIPTION
MBAR2 + 0xA2	RW	8	PhaseConfig	Configure phase measurement circuit
MBAR2 + BAS 0xA6:0xA7	RW	16	Xtrim	Value output on XTRIM pin
MBAR2 BAS + 0xA8:0xAB	R	32	FreqMeas	Phase /Frequency measurement
MBAR2 + 0xC8	RW	32	blockControl	Block decoder/encoder control
MBAR2 + 0xCE	RW	16	audioGlob	fifo sync mechanism, audioTick interrupt

Section 18

I²C Modules

18.1 I²C OVERVIEW

The MCF5249 provides dual I²C interface capability. This bus was formerly referred to as the Motorola Bus (MBUS). The I²C interface described in this section is fully compatible with the I²C Bus Standard.

Note: The second I²C module pins are muxed with the QSPI module.
Select the I²C function for these pins using the PLLCR register.

The I²C is a two-wire, bidirectional serial bus that provides a simple and efficient method of data exchange between devices. This two-wire bus minimizes the interconnection between devices.

The I²C bus is suitable for applications requiring occasional communications over a short distance between many devices. The flexible I²C allows additional devices to be connected to the bus for expansion and system development.

The interface operates up to 100 kbps with maximum bus loading and timing.

The I²C system is a true multimaster bus including collision detection and arbitration that prevents data corruption if two or more masters attempt to control the bus simultaneously. This feature allows for complex applications with multiprocessor control. It can also be used for rapid testing and alignment of end products using external connections to an assembly line computer.

18.2 I²C INTERFACE FEATURES

- Compatibility with I²C Bus standard
- Multimaster operation
- Software-programmable for one of 64 different serial clock frequencies
- Software-selectable acknowledge bit
- Interrupt-driven byte-by-byte data transfer
- Arbitration-lost interrupt with automatic mode switching from master to slave
- Calling address identification interrupt
- Start and stop signal generation/detection
- Repeated START signal generation
- Acknowledge bit generation/detection
- Bus-busy detection

Figure 18-1 shows a block diagram of the I²C module.

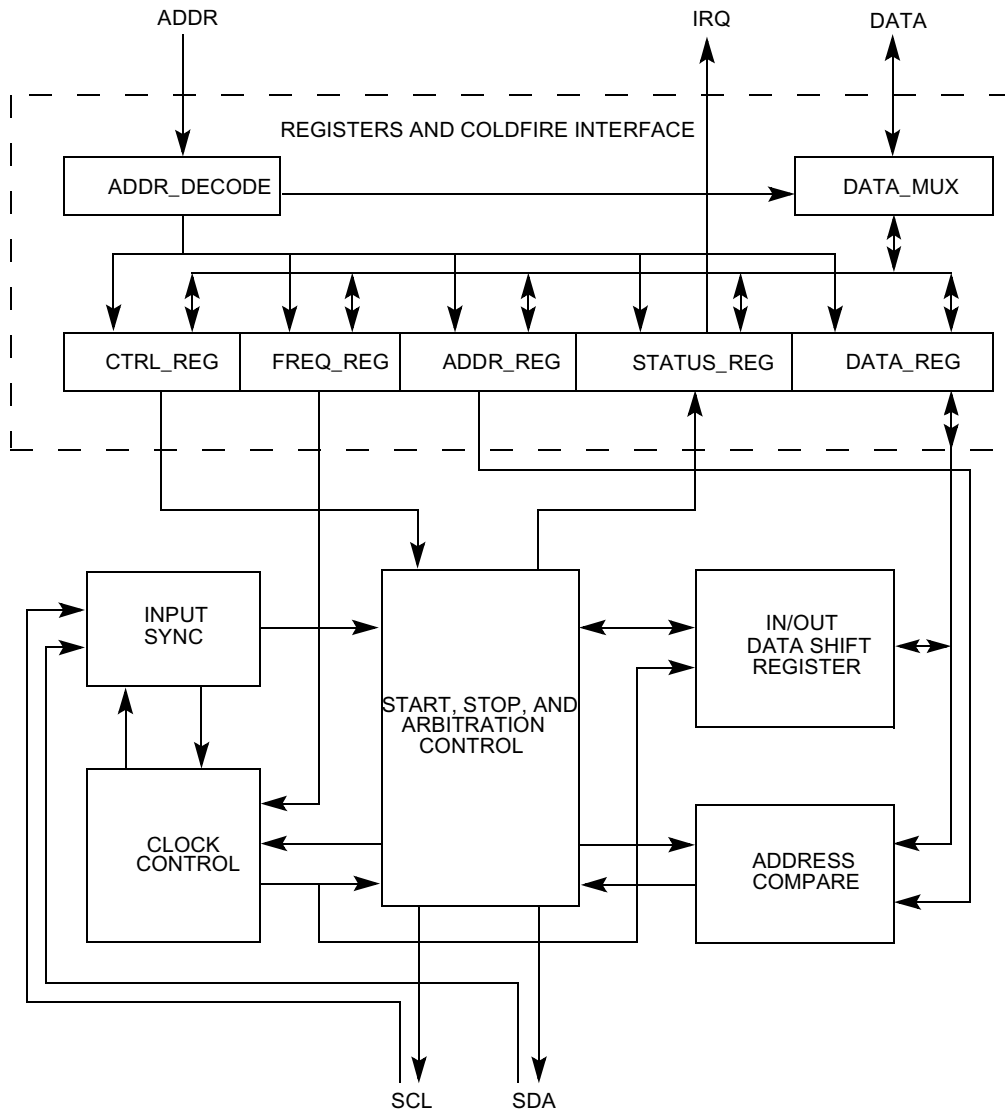

Figure 18-1 I²C Module Block Diagram

18.3 I²C SYSTEM CONFIGURATION

I²C module uses a serial data line (SDA) and a serial clock line (SCL) for data transfer. All devices connected to these two signals must have open drain or open collector outputs. The logic AND function is exercised on both lines with external pullup resistors.

The default state of I²C is as a slave receiver out of reset. Thus, when not programmed to be a master or responding to a slave transmit address, the I²C module should always return to the default state of slave receiver (check section [18.6.1 Initialization Sequence](#) for exceptions).

Note: This I²C module is designed to be compatible with the I²C bus protocol from Philips. For further information on I²C system configuration, protocol, and restrictions please refer to the Philips I²C Standard

18.4 I²C PROTOCOL

A standard communication is composed of four parts:

1. START signal
2. Slave address transmission
3. Data transfer
4. STOP signal

They are described briefly in the following sections and shown in [Figure 18-2](#).

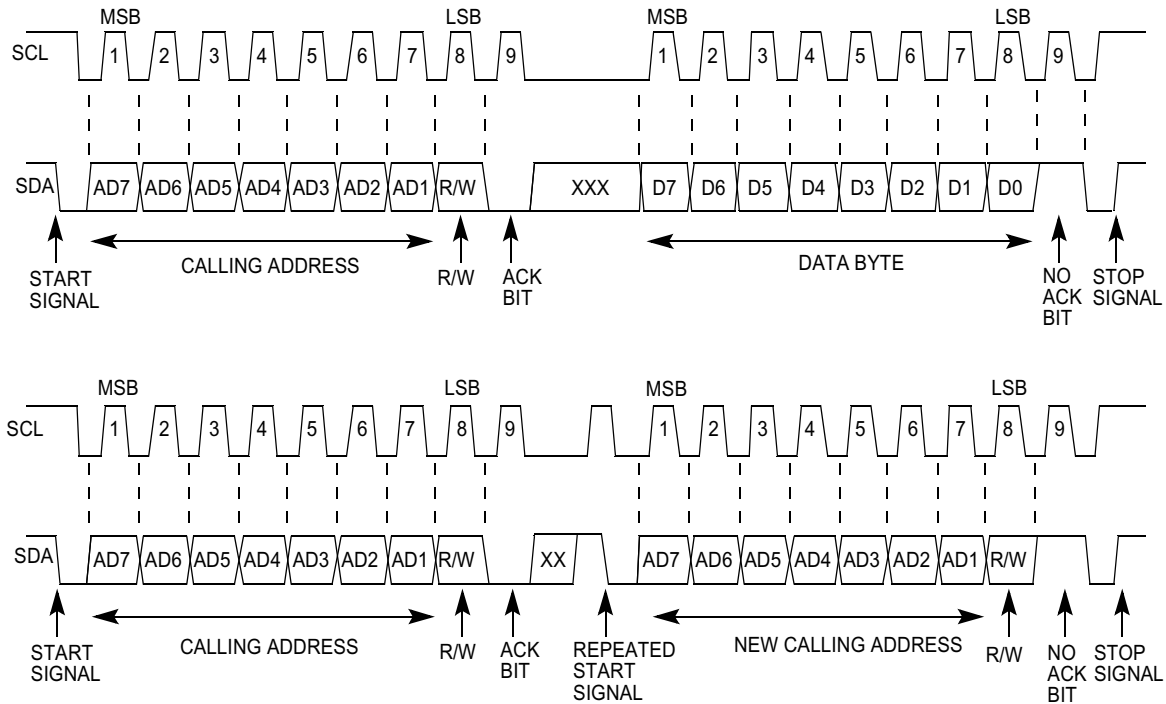

Figure 18-2 I²C Standard Communication Protocol

18.4.1 START SIGNAL

When the bus is free, i.e., no master device is engaging the bus (both SCL and SDA lines are at logic high), a master can initiate communication by sending a START signal. As shown in [Figure 18-2](#), a START signal is defined as a high-to-low transition of SDA while SCL is high. This signal denotes the beginning of a new data transfer (each data transfer can contain several bytes of data) and awakens all slaves.

18.4.2 SLAVE ADDRESS TRANSMISSION

The first byte of data transferred by the master immediately after the START signal is the slave address. This is a seven-bit calling address followed by a R/W bit. The R/W bit tells the slave data transfer direction. No two slaves in the system can have the same address. In addition, if the I²C is master, it must not transmit an address that is equal to its slave address. The I²C cannot be master and slave at the same time.

Only the slave with an address that matches the one transmitted by the master will respond. It returns an acknowledge bit by pulling the SDA low at the 9th clock (see [Figure 18-2](#)).

18.4.3 DATA TRANSFER

Once successful slave addressing is achieved, the data transfer can proceed on a byte-by-byte basis in the direction specified by the R/W bit sent by the calling master.

Each data byte is 8 bits long. Data can be changed only while SCL is low and must be held stable while SCL is high, as shown in [Figure 18-2](#). There is one clock pulse on SCL for each data bit with the MSB being transferred first. Each byte of data must be followed by an acknowledge bit, which is signalled from the receiving device by pulling the SDA low at the ninth clock. One complete data byte transfer needs nine clock pulses.

If the slave receiver does not acknowledge the master, the SDA line must be left high by the slave. The master can then generate a stop signal to abort the data transfer or a start signal (repeated start) to start a new calling sequence.

If the master receiver does not acknowledge the slave transmitter after a byte transmission, it means “end of data” to the slave. The slave releases the SDA line for the master to generate a STOP or START signal.

18.4.4 REPEATED START SIGNAL

As shown in [Figure 18-2](#), a repeated START signal is a START signal generated without first generating a STOP signal to terminate the communication. The master uses this method to communicate with another slave or with the same slave in a different mode (transmit/receive mode) without releasing the bus.

18.4.5 STOP SIGNAL

The master can terminate the communication by generating a STOP signal to free the bus. However, the master can generate a START signal followed by a calling command without generating a STOP signal first. This is called repeated START. A STOP signal is defined as a low-to-high transition of SDA while SCL is at logical 1 (see [Figure 18-2](#)).

Note: A master can generate a STOP even if the slave has made an acknowledgment at which point the slave must release the bus.

18.4.6 ARBITRATION PROCEDURE

I²C is a true multimaster bus that allows connection to more than one master. If two or more masters try to simultaneously control the bus, a clock synchronization procedure determines the bus clock, for which the low period is equal to the longest clock low period and the high is equal to the shortest one among the devices. A data arbitration procedure determines the relative priority of the contending masters. A bus master loses arbitration if it transmits logic 1 while another master transmits logic 0. The losing masters immediately switch over to slave-receive mode and stop driving SDA output. In this case, the transition from master to slave mode does not generate a STOP condition. Meanwhile, hardware sets MBSR[IAL] to indicate loss of arbitration.

18.4.7 CLOCK SYNCHRONIZATION

Because wire-AND logic is performed on SCL line, a high-to-low transition on SCL line affects all the devices connected on the bus. The devices start counting their low period when the master drives the SCL line low. Once a device clock has gone low, it holds the SCL line low until the clock high state is reached. However, the change of low to high in the MCF5249 clock may not change the state of the SCL line if another device clock is still within its low period. Therefore, synchronized clock SCL is held low by the device with the longest low period. Devices with shorter low periods enter a high wait state during this time (see [Figure 18-3](#)). When all devices concerned have counted off their low period, the synchronized clock

SCL line is released and pulled high. At this point, there is no difference between the device clocks and the state of the SCL line and all the devices start counting their high periods. The first device to complete its high period pulls the SCL line low again.

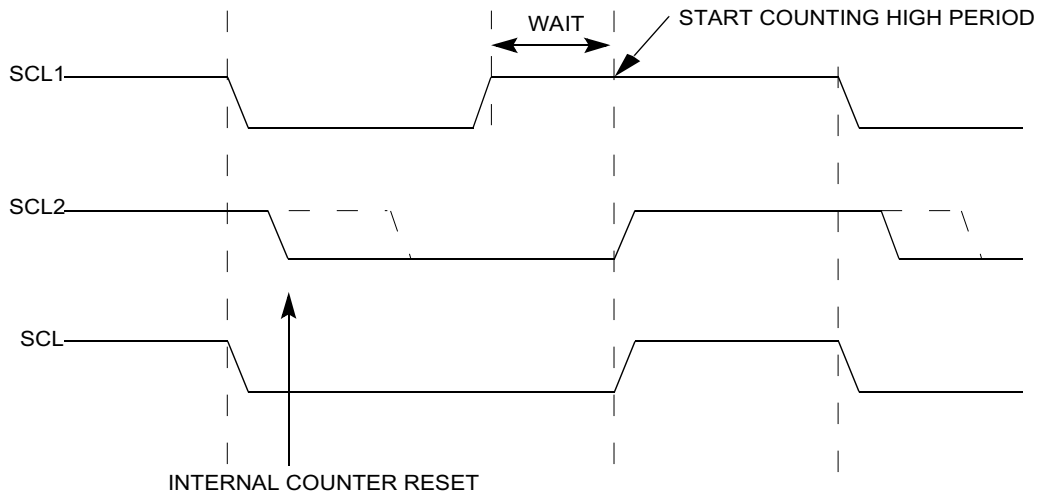

Figure 18-3 Synchronized Clock SCL

18.4.8 HANDSHAKING

The clock synchronization mechanism can be used as a handshake in data transfer. Slave devices can hold the SCL line low after completion of one byte transfer (9 bits). In such cases, it halts the bus clock and forces the master clock into wait states until the slave releases the SCL line.

18.4.9 CLOCK STRETCHING

Slaves can use the clock synchronization mechanism to slow down the transfer bit rate. After the master has driven SCL low, the slave can drive SCL low for the required period and then release it. If the slave SCL low period is greater than the master SCL low period, the resulting SCL bus signal low period is stretched.

18.5 PROGRAMMING MODEL

Internal configuration of the five registers used in the I²C interface are detailed in the following subsections. Table 18-1 shows the programmer's model of the I²C interface.

Table 18-1 I²C Interfaces Programmer's Model

ADDRESS	I ² C MODULE REGISTERS
MBAR+\$280	I ² C Address Register (MADR)
MBAR+\$284	I ² C Frequency Divider Register (MFDR)
MBAR+\$288	I ² C Control Register (MBCR)

Table 18-1 I²C Interfaces Programmer's Model (Continued)

ADDRESS	I ² C MODULE REGISTERS
MBAR+\$28C	I ² C Status Register (MBSR)
MBAR+\$290	I ² C Data I/O Register (MBDR)
MBAR2 + \$440	MBAR2 I ² C Address Register (MADR2)
MBAR2 + \$444	MBAR2 I ² C Frequency Divider Register (MFDR2)
MBAR2 + \$448	MBAR2 I ² C Control Register (MBCR2)
MBAR2 + \$44C	MBAR2 I ² C Status Register (MBSR2)
MBAR2 + \$450	MBAR2 I ² C Data I/O Register (MBDR2)

Note: External masters cannot access the MCF5249 on-chip memories or MBAR, but can access any I²C module register.

18.5.1 I²C ADDRESS REGISTERS (MADR)

This register contains the address that the I²C will respond to when addressed as a slave.

Note: It is not the address sent on the bus during the address transfer.

Table 18-2 MADR Register

BITS	7	6	5	4	3	2	1	0
FIELD	ADR7	ADR6	ADR5	ADR4	ADR3	ADR2	ADR1	-
RESET	0	0	0	0	0	0	0	0
R/W	READ/WRITE SUPERVISOR OR USER MODE							
ADDR	MBAR+\$280 (MADR) MBAR2+\$440 (MADR2)							

Table 18-3 MADR Bit Descriptions

BIT NAME	DESCRIPTION
ADR7–ADR1 — Slave Address	Bit 1 to bit 7 contain the specific slave address to be used by the I ² C module. Slave mode is the default I ² C mode for an address match on the bus.

18.5.2 I²C FREQUENCY DIVIDER REGISTERS (MFDR)

The MFDR provides a programmable prescaler to configure the clock for bit rate selection.

Table 18-4 MFDR Register

BITS	7	6	5	4	3	2	1	0
FIELD	-	-	IC5	IC4	IC3	IC2	IC1	IC0
RESET	0	0	0	0	0	0	0	0
R/W	READ/WRITE SUPERVISOR OR USER MODE							
ADDR	MBAR+ \$284 (MFDR) MBAR2+ \$444 (MFDR2)							

Table 18-5 MFDR Bit Descriptions

BIT NAME	DESCRIPTION
IC5-IC0 —I ² C Clock Rate 5-0	This field is used to prescale the clock for bit rate selection. Due to the potential slow rise and fall times of the SCL and SDA signals, bus signals are sampled at the prescaler frequency. The serial bit clock frequency is equal to the system clock divided by the divider shown in Table 18-6 (In previous implementations of the I ² C (e.g., MC68307), the IBC[5] (IC[5]) bit was not implemented. Clearing this bit in software maintains complete compatibility with such products.)
Note: The MFDR frequency value can be changed at any point in a program.	

Table 18-6 I²C Prescaler Values

MBC5-0 (HEX)	DIVIDER (DEC)	MBC5-0 (HEX)	DIVIDER (DEC)
00	28	20	20
01	30	21	22
02	34	22	24
03	40	23	26
04	44	24	28
05	48	25	32
06	56	26	36
07	68	27	40
08	80	28	48
09	88	29	56
0A	104	2A	64
0B	128	2B	72
0C	144	2C	80
0D	160	2D	96
0E	192	2E	112
0F	240	2F	128
10	288	30	160
11	320	31	192
12	384	32	224

Table 18-6 I²C Prescaler Values (Continued)

MBC5-0 (HEX)	DIVIDER (DEC)	MBC5-0 (HEX)	DIVIDER (DEC)
13	480	33	256
14	576	34	320
15	640	35	384
16	768	36	448
17	960	37	512
18	1152	38	640
19	1280	39	768
1A	1536	3A	896
1B	1920	3B	1024
1C	2304	3C	1280
1D	2560	3D	1536
1E	3072	3E	1792
1F	3840	3F	2048

18.5.3 I²C CONTROL REGISTERS (MBCR)

The MBCR enable the I²C module and the I²C interrupt. It also contains the bits that govern operation as Master or Slave.

Table 18-7 MBCR Register

BITS	7	6	5	4	3	2	1	0
FIELD	IEN	IIEN	MSTA	MTX	TXAK	RSTA	-	
RESET	0	0	0	0	0	0	0	0
R/W	READ/WRITE SUPERVISOR OR USER MODE							
ADDR	MBAR+ \$288 (MBCR) MBAR2+ \$448 (MBCR2)							

Table 18-8 MBCR Bit Descriptions

BIT NAME	DESCRIPTION
IEN	<p>The I²C Enable bit controls the software reset of the entire I²C module.</p> <p>1 = The I²C module is enabled. This bit must be set before any other MBCR bits have any effect.</p> <p>0 = The module is disabled, but registers can still be accessed.</p> <p>If the I²C module is enabled in the middle of a byte transfer, the interface behaves as follows: The slave mode ignores the current transfer on the bus and starts operating whenever a subsequent start condition is detected. Master mode will not be aware that the bus is busy; therefore, if a start cycle is initiated, the current bus cycle can become corrupt. This ultimately results in either the current bus master or the I²C module losing arbitration, after which bus operation returns to normal.</p>
IEN	<p>I²C Interrupt Enable</p> <p>1 = Interrupts from the I²C module are enabled. An I²C interrupt occurs provided the IIF bit in the status register is also set.</p> <p>0 = Interrupts from the I²C module are disabled. This does not clear any currently pending interrupt condition.</p>
MSTA	<p>At reset, the Master/Slave Mode Select Bit is cleared. When this bit is changed from 0 to 1, a START signal is generated on the bus, and the master mode is selected. When this bit is changed from 1 to 0, a STOP signal is generated and the operation mode changes from master to slave.</p> <p>MSTA is cleared without generating a STOP signal when the master loses arbitration.</p> <p>1 = Master Mode 0 = Slave Mode</p>
MTX	<p>The Transmit/Receive Mode Select Bit selects the direction of master and slave transfers. When addressed as a slave this bit should be set by software according to the SRW bit in the status register. In master mode, this bit should be set according to the type of transfer required. Therefore, for address cycles, this bit will always be high.</p> <p>1 = Transmit 0 = Receive</p>
TXAK	<p>The Transmit Acknowledge Enable bit specifies the value driven onto SDA during acknowledge cycles for both master and slave receivers.</p> <p>Writing this bit only applies when the I²C bus is a receiver, not a transmitter.</p> <p>1 = No acknowledge signal response is sent (i.e., acknowledge bit = 1)</p> <p>0 = An acknowledge signal will be sent out to the bus at the 9th clock bit after receiving one byte data</p>
RSTA	<p>Writing a 1 to the Repeat Start bit will generate a repeated START condition on the bus, provided it is the current bus master. This bit will always be read as a low. Attempting a repeated start at the wrong time, if the bus is owned by another master, will result in loss of arbitration.</p> <p>1 = Generate repeat start cycle 0 = No repeat start</p>

18.5.4 I²C STATUS REGISTERS (MBSR)

This status register is read-only with the exception of bit 1 (IIF) and bit 4 (IAL), which can be cleared by software. All bits are cleared on reset except bit 7 (ICF) and bit 0 (RXAK), which are set (=1) at reset.

Table 18-9 MBSR Register

BITS	7	6	5	4	3	2	1	0
FIELD	ICF	IAAS	IBB	IAL	-	SRW	IIF	RXAK
RESET	1	0	0	0	0	0	0	1
R/W	READ/WRITE SUPERVISOR OR USER MODE							
ADDR	MBAR+ \$28C (MBSR) MBAR2+ \$44C (MBSR2)							

Table 18-10 MBSR Bit Descriptions

BIT NAME	DESCRIPTION
ICF	While one byte of data is being transferred, the Data Transferring Bit bit is cleared. It is set by the falling edge of the 9th clock of a byte transfer. 1 = Transfer complete 0 = Transfer in progress
IAAS	When its own specific address (I ² C Address Register) is matched with the calling address, the Addressed as a Slave Bit is set. The CPU is interrupted provided the ILEN is set. Next, the CPU must check the SRW bit and set its TX/RX mode accordingly. Writing to the I ² C Control Register clears this bit. 1 = Addressed as a slave 0 = Not addressed
IBB	The Bus Busy Bit indicates the status of the bus. When a START signal is detected, the IBB is set. If a STOP signal is detected, it is cleared. 1 = Bus is busy 0 = Bus is idle
IAL	Hardware sets the Arbitration Lost bit (IAL) when the arbitration procedure is lost. Arbitration is lost in the following circumstances: SDA sampled as low when the master drives a high during an address or data-transmit cycle. SDA sampled as a low when the master drives a high during the acknowledge bit of a data-receive cycle. A start cycle is attempted when the bus is busy. A repeated start cycle is requested in slave mode. A stop condition is detected when the master did not request it. This bit must be cleared by software by writing a zero to it.

Table 18-10 MBSR Bit Descriptions (Continued)

BIT NAME	DESCRIPTION
SRW	When IAAS is set, the Slave Read/Write bit indicates the value of the R/W command bit of the calling address sent from the master. This bit is valid only when: A complete transfer has occurred and no other transfers have been initiated. I ² C is a slave and has an address match. Checking this bit, the CPU can select slave transmit/receive mode according to the command of the master. 1 = Slave transmit, master reading from slave 0 = Slave receive, master writing to slave
IIF	The I ² C Interrupt (IIF) bit is set when an interrupt is pending, which will cause a processor interrupt request (provided I IEN is set). IIF is set when one of the following events occurs: Complete one byte transfer (set at the falling edge of the 9th clock) Receive a calling address that matches its own specific address in slave-receive mode Arbitration lost This bit must be cleared by software by writing a zero to it in the interrupt routine.
RXAK	The value of SDA during the acknowledge bit of a bus cycle. If the received acknowledge bit (RXAK) is low, it indicates an acknowledge signal has been received after the completion of 8 bits data transmission on the bus. If RXAK is high, it means no acknowledge signal has been detected at the 9th clock. 1 = No acknowledge received 0 = Acknowledge received

18.5.5 I²C DATA I/O REGISTERS (MBDR)

Table 18-11 MBDR Register

BITS	7	6	5	4	3	2	1	0
FIELD	D7	D6	D5	D4	D3	D2	D1	D0
RESET	0	0	0	0	0	0	0	0
R/W	READ/WRITE SUPERVISOR OR USER MODE							
ADDR	MBAR+\$290 (MBDR) MBAR2+\$450 (MBDR2)							

When an address and R/W bit is written to the MBDR and the I²C is the master, a transmission will start. When data is written to the MBDR, a data transfer is initiated. The most significant bit is sent first in both cases. In the master-receive mode, reading the MBDR register allows the read to occur but also initiates next byte data receiving. In slave mode, the same function is available after it is addressed.

18.6 I²C PROGRAMMING EXAMPLES

18.6.1 INITIALIZATION SEQUENCE

A reset places the I²C Control Register into default status. Before the interface can transfer serial data, users must perform an initialization procedure as follows:

1. Update the Frequency Divider Register (MFDR) and select the required division ratio to obtain SCL frequency from the system bus clock.
2. Update the I²C Address Register (MADR) to define its slave address.
3. Set the IEN bit of the I²C Control Register (MBCR) to enable the I²C bus interface system.
4. Modify the MBCR to select master/slave mode, transmit/receive mode, and interrupt-enable or not.

Note: During the initialization of the I²C bus module, the user should check the IBB bit of the MBSR register. If the IBB bit is set when the I²C module is enabled, then the following code sequence should be executed before proceeding with the normal initialization code. This issues a STOP command to the slave device, which places it into the idle state as if it were recently power cycled.

```
MBCR = $0
MBCR = $A0
dummy read of MBDR
MBSR = $0
MBCR = $0
```

18.6.2 GENERATION OF START

After completion of the initialization procedure, users can transmit serial data by selecting the “master transmitter” mode. If the MCF5249 is connected to a multimaster bus system, users must test the state of the I²C Busy Bit (IBB) to check whether the serial bus is free.

If the bus is free (IBB=0), the start condition and the first byte (the slave address) can be sent. The data written to the data register comprises the address of the desired slave and the LSB is set to indicate the direction of transfer required.

The bus free time (i.e., the time between a STOP condition and the following START condition) is built into the hardware that generates the START cycle. Depending on the relative frequencies of the system clock and the SCL period, users may have to wait until the I²C is busy after writing the calling address to the MBDR before proceeding with the following instructions.

An example of a program that generates the START signal and transmits the first byte of data (slave address) is shown as follows:

```
CHFLAG MOVE.B MBSR,-(A7);Check the MBB bit of the MBSR
BTST.B #5, (A7)+
BNE.S CHFLAG;If it is set, wait until it is clear

TXSTART MOVE.BMBCR,-(A7);Set transmit mode
BSET.B #4,(A7)
MOVE.B (A7)+, MBCR
MOVE.B MBCR, -(A7);Set master mode
BSET.B #5, (A7);Generate START condition
```

```
MOVE.B (A7)+, MBCR;
MOVE.B CALLING,-(A7);Transmit the calling address, D0=R/W
MOVE.B (A7)+, MBDR;
```

```
IFREE MOVE.B MBSR,-(A7);Check the IBB bit of the MBSR.
;If it is clear, wait until it is set.
BTST.B #5, (A7)+;
BEQ.S IBFREE;
```

18.6.3 POST-TRANSFER SOFTWARE RESPONSE

Transmission or reception of a byte will set the data transferring bit (ICF) to 1, which indicates one byte communication is finished. The interrupt bit (IIF) is also set. An interrupt will be generated if the interrupt function is enabled during initialization by setting the I IEN bit. Software must clear the IIF bit in the interrupt routine first. The ICF bit will be cleared by reading from the I²C Data I/O Register (MBDR) in receive mode or writing to MBDR in transmit mode.

Software can service the I²C I/O in the main program by monitoring the IIF bit if the interrupt function is disabled. Polling should monitor the IIF bit rather than the ICF bit because that operation is different when arbitration is lost.

When an interrupt occurs at the end of the address cycle, the master will always be in transmit mode. For example, the address is transmitted. If master receive mode is required, indicated by MBDR[R/W], then the MTX bit should be toggled.

During slave-mode address cycles (IAAS=1), the SRW bit in the status register is read to determine the direction of the subsequent transfer and the MTX bit is programmed accordingly. For slave-mode data cycles (IAAS=0), the SRW bit is not valid. The MTX bit in the control register should be read to determine the direction of the current transfer.

The following is an example of a software response by a "master transmitter" in the interrupt routine (see [Figure 18-4](#)).

```
MBSR LEA.L MBSR,-(A7);Load effective address
BCLR.B #1,(A7)+;Clear the IIF flag
MOVE.B MBCR,-(A7);Push the address on stack,
BTST.B #5,(A7)+;check the MSTA flag
BEQ.S SLAVE;Branch if slave mode
MOVE.B MBCR,-(A7);Push the address on stack
BTST.B #4,(A7)+;check the mode flag
BEQ.S RECEIVE;Branch if in receive mode
MOVE.B MBSR,-(A7);Push the address on stack,
BTST.B #0,(A7)+;check ACK from receiver
BNE.B
END;If no ACK, end of transmission
```

```
TRANSMIT MOVE.B DATABUF,-(A7);Stack data byte
MOVE.B (A7)+, MBDR);Transmit next byte of data
Generation of STOP
```

A data transfer ends with a STOP signal generated by the "master" device. A master transmitter can generate a STOP signal after all the data has been transmitted. The following code is an example showing how a master transmitter generates a stop condition.

```
MASTX
MOVE.B MBSR, -(A7); If no ACK, branch to end
```

```

BTST.B #0,(A7)+
BNE.B END
MOVE.B TXCNT,D0;Get value from the transmitting counter
BEQ.S END;If no more data, branch to end
MOVE.B DATABUF,-(A7);Transmit next byte of data
MOVE.B (A7)+,MBDR
MOVE.B TXCNT,D0;Decrease the TXCNT
SUBQ.L #1,D0
MOVE.B D0,TXCNT
BRA.S EMAXTX;Exit
END LEA.L MBCR,-(A7);Generate a STOP condition
BCLR.B #5,(A7)+
EMASTX RTE; Return from interrupt
    
```

If a master receiver wants to terminate a data transfer, it must inform the slave transmitter by not acknowledging the last byte of data, which can be done by setting the transmit acknowledge bit (TXAK) before reading the next-to-last byte of data. Before reading the last byte of data, a STOP signal must first be generated. The following code is an example showing how a master receiver generates a STOP signal.

```

MASR MOVE.B RXCNT,D0;Decrease RXCNT
SUBQ.L #1,D0
MOVE.B D0,RXCNT
BEQ.S ENMASR;Last byte to be read
MOVE.B RXCNT,D1;Check second-to-last byte to be read
EXTB.L D1
SUBI.L #1,D1;
BNE.S NXMAR; Not last one or second last
LAMAR BSET.B #3,MBCR;Disable ACK
BRA NXMAR
ENMASR BCLR.B #5,MBCR; Last one, generate 'STOP'signal
NXMAR MOVE.B MBDR,RXBUF; Read data and store RTE
Generation of Repeated START
At the end of data transfer, if the master still wants to communicate on the bus, it can generate another START signal followed
by another slave address without first generating a STOP signal. A program example follows.
RESTART MOVE.B MBCR,-(A7); Another START (RESTART)
BSET.B #2, (A7)
MOVE.B (A7)+, MBCR
MOVE.B CALLING,-(A7);Transmit the calling address, D0=R/W-
MOVE.B CALLING,-(A7);
MOVE.B (A7)+, MBDR
    
```

18.6.4 SLAVE MODE

In the slave interrupt service routine, the module that is addressed as slave bit (IAAS), should be tested to check if a calling of its own address was received. If IAAS is set, software should set the transmit/receive mode select bit (MTX bit of MBCR) according to the R/W command bit (SRW). Writing to the MBCR clears the IAAS automatically. The only time IAAS is read as set is from the interrupt at the end of the address cycle where an address match occurred; interrupts resulting from subsequent data transfers will have IAAS cleared. A data transfer can now be initiated by writing information to MBDR, for slave transmits, or read from MBDR, in slave-receive mode. A dummy read of the MBDR in slave/receive mode will release SCL, allowing the master to transmit data.

In the slave transmitter routine, the received acknowledge bit (RXAK) must be tested before transmitting the next byte of data. Setting RXAK means an “end-of-data” signal from the master receiver, after which it must be switched from transmitter mode to receiver mode by software. A read from MBDR then releases the SCL line so that the master can generate a STOP signal.

18.6.5 ARBITRATION LOST

If several devices try to engage the bus at the same time, only one becomes master and the others lose arbitration. The devices that lost arbitration are immediately switched to slave receive mode by the hardware. Their data output to the SDA line is stopped, but SCL is still generated until the end of the byte during which arbitration was lost. An interrupt occurs at the falling edge of the ninth clock of this transfer with IAL=1 and MSTA=0. If one master tries to transmit or do a START while the bus is being engaged by another master, the hardware does the following:

1. Inhibits the transmission
2. Switches the MSTA bit from 1 to 0 without generating STOP condition
3. Generates an interrupt to CPU
4. Sets the IAL to indicate the failed attempt to engage the bus.

When considering these cases, the slave service routine should test the IAL first and the software should clear the IAL bit if it is set.

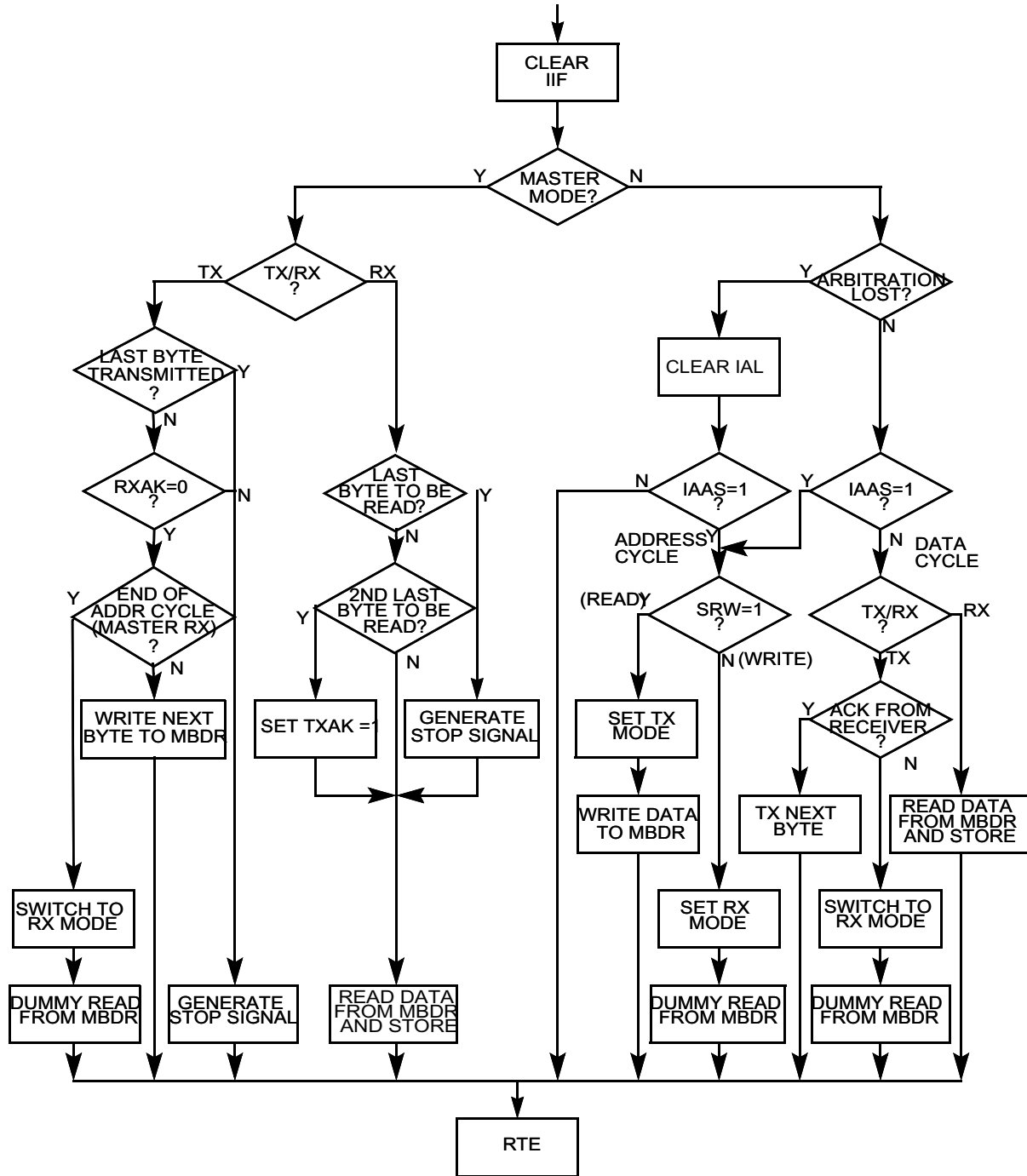

Figure 18-4 Flow-Chart of Typical I²C Interrupt Routine

Section 19

Debug Support

This section details the MCF5249 hardware debug support. The MCF5249 implements an enhanced debug architecture. The original design plus these enhancements is known as Revision A (or Rev. A). The enhanced functionality is clearly identified in this section. The Rev. A enhancements are backward compatible with the original ColdFire debug definition.

The general topic of debug support is divided into three separate areas:

1. Real-Time Trace Support
2. Background Debug Mode (BDM)
3. Real-Time Debug Support

Note: To enable Debug Mode, MTMOD[3:0] pins must be = 0001.

The logic required to support these three areas is contained in a debug module as shown in [Figure 19-1](#).

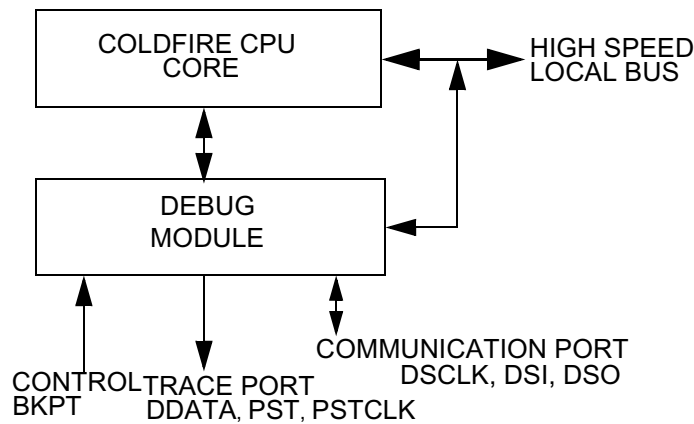

Figure 19-1 Processor/Debug Module Interface

19.1 BREAKPOINT ($\overline{\text{BKPT}}$)

This section describes signals associated with the debug module. All ColdFire debug signals are unidirectional and are related to the rising-edge of the processor core's clock signal.

19.1.1 DEBUG SUPPORT SIGNALS

The $\overline{\text{BKPT}}$ active-low input signal is used to request a manual breakpoint. Its assertion causes the processor to enter a halted state after the completion of the current instruction. The halt status is reflected on the processor status (PST) pins as the value \$F.

19.1.2 DEBUG DATA (DDATA[3:0])

These output signals display the hardware register breakpoint status as a default, or optionally, captured address and operand values. The capturing of data values is controlled by the setting of the

configuration/status register (CSR). Additionally, execution of the WDDATA instruction by the processor captures operands which are displayed on DDATA. These signals are updated each processor cycle.

19.1.3 DEVELOPMENT SERIAL CLOCK (DSCLK)

This input signal is synchronized internally and provides the clock for the serial communication port to the debug module. The maximum frequency is 1/5 the speed of the processor's clock (CLK). At the synchronized rising edge of DSCLK, the data input on DSI is sampled, and the DSO output changes state. See [Figure 19-3](#) for more information,

19.1.4 DEVELOPMENT SERIAL INPUT (DSI)

The input signal is synchronized internally and provides the data input for the serial communication port to the debug module.

19.1.5 DEVELOPMENT SERIAL OUTPUT (DSO)

This signal provides serial output communication for the debug module responses.

19.1.6 PROCESSOR STATUS (PST[3:0])

These output signals report the processor status. [Table 19-1](#) shows the encoding of these signals. These outputs indicate the current status of the processor pipeline and are not related to the current bus transfer. The PST value is updated each processor cycle.

Table 19-1 Processor Status Encoding

PST[3:0]		DEFINITION
(HEX)	(BINARY)	
\$0	0000	Continue execution
\$1	0001	Begin execution of an instruction
\$2	0010	Reserved
\$3	0011	Entry into user-mode
\$4	0100	Begin execution of PULSE and WDDATA instructions
\$5	0101	Begin execution of taken branch or Sync_PC
\$6	0110	Reserved
\$7	0111	Begin execution of RTE instruction
\$8	1000	Begin 1-byte transfer on DDATA
\$9	1001	Begin 2-byte transfer on DDATA
\$A	1010	Begin 3-byte transfer on DDATA
\$B	1011	Begin 4-byte transfer on DDATA
\$C	1100	Exception processing†
\$D	1101	Emulator-mode entry exception processing†
\$E	1110	Processor is stopped, waiting for interrupt†
\$F	1111	Processor is halted †

Note: †These encodings are asserted for multiple cycles.

19.1.7 PROCESSOR STATUS CLOCK (PSTCLK)

Since the debug trace port signals transition each processor cycle and is not related to the external bus frequency, an additional signal is output from the ColdFire microprocessor. The PSTCLK signal is a delayed version of the processor's high-speed clock and its rising-edge is used by the development system to sample the values on the PST and DDATA output buses. The PSTCLK signal is intended for use in the standard 26-pin debug connector. See [Figure 19-26](#).

If the real-time trace functionality is not being used, the PCD bit of the CSR may be set (CSR[17] = 1) to force the PSTCLK, PST and DDATA outputs to be quiescent.

19.2 REAL-TIME TRACE SUPPORT

In the area of debug functions, one fundamental requirement is support for real-time trace functionality. For example, definition of the dynamic execution path. The ColdFire solution is to include a parallel output port providing encoded processor status and data to an external development system. This port is partitioned into two nibbles (4 bits): one nibble allows the processor to transmit information concerning the execution status of the core (processor status: PST), while the other nibble allows operand data to be displayed. (debug data: DDATA). The processor status (PST) timing is synchronous with the processor status clock (PSTCLK) and may not be related to the current bus transfer. Table 19-1 shows the encoding of these signals.

The PST outputs can be used with an external image of the program to completely track the dynamic execution path of the machine when used with external development systems. The tracking of this dynamic path is complicated by any change-of-flow operation. This is especially evident when the branch target address is calculated based on the contents of a program-visible register (variant addressing.) For this reason, the DDATA outputs can be configured to display the target address of these types of change-of-flow instructions. Because the DDATA bus is only 4 bits wide, the address is displayed a nibble at a time across multiple clock cycles.

The debug module includes two 32-bit storage elements for capturing the internal ColdFire bus information. These two elements effectively form a FIFO buffer connecting the processor's high-speed local bus to the external development system through the DDATA signals. The FIFO buffer captures branch target addresses along with certain operand data values for eventual display on the DDATA output port, a nibble at a time, starting with the least-significant bit. The execution speed of the ColdFire processor is affected only when both storage elements contain valid data waiting to be dumped onto the DDATA port. In this case, the processor core is stalled until one FIFO entry is available. In all other cases, data output on the DDATA port does not impact execution speed.

19.2.1 PROCESSOR STATUS SIGNAL ENCODING

The PST signals are encoded to reflect the state of the Operand Execution Pipeline, and are generally not related to the current external bus transfer.

19.2.1.1 Continue Execution (PST = \$0)

Many instructions complete in a single processor cycle. If an instruction requires more clock cycles, the subsequent clock cycles are indicated by driving the PST outputs with this encoding.

19.2.1.2 Begin Execution of an Instruction (PST = \$1)

For most instructions, this encoding signals the first clock cycle of an instruction's execution. Certain change-of-flow opcodes, plus the PULSE and WDDATA instructions generate different encodings.

19.2.1.3 Entry into User Mode (PST = \$3)

This encoding indicates the ColdFire processor has entered user mode. This encoding is signaled after the instruction which caused the user mode entry has executed.

19.2.1.4 Begin Execution of PULSE or WDDATA instructions (PST = \$4)

The ColdFire instruction set architecture includes a PULSE opcode. This opcode generates a unique PST encoding, \$4, when executed. This instruction can define logic analyzer triggers for debug and/or performance analysis. Additionally, a WDDATA instruction is supported that allows the processor core to write any operand (byte, word, longword) directly to the DDATA port, independent of any debug module configuration. This opcode also generates the special PST encoding (\$4) when executed, followed by the

appropriate marker and then the data transfer on the DDATA outputs. The length of the data transfer is dependent on the operand size of the WDDATA instruction.

19.2.1.5 Begin Execution of Taken Branch (PST = \$5)

This encoding is generated whenever a taken branch is executed. For certain opcodes, the branch target address may be optionally displayed on DDATA depending on the control parameters contained in the configuration/status register (CSR). The number of bytes of the address to be displayed is also controlled in the CSR and indicated by the PST marker value immediately preceding the DDATA outputs.

The bytes are always displayed in a least-significant to most-significant order. The processor captures only those target addresses associated with taken branches using a variant addressing mode. For example, all JMP and JSR instructions using address register indirect or indexed addressing modes, all RTE and RTS instructions as well as all exception vectors.

The simplest example of a branch instruction using a variant address is the compiled code for a C language “case” statement. Typically, the evaluation of this statement uses the variable of an expression as an index into a table of offsets, where each offset points to a unique case within the structure. For these types of change-of-flow operations, the ColdFire processor uses the debug pins to output a sequence of information on successive processor clock cycles:

1. Identify a taken branch has been executed using the PST pins (\$5).
2. Using the PST pins, optionally signal the target address is to be displayed on the DDATA pins. The encoding (\$9, \$A, \$B) identifies the number of bytes that are displayed.
3. The new target address is optionally available on subsequent cycles using the nibble-wide DDATA port. The number of bytes of the target address displayed on this port is a configurable parameter (2, 3, or 4 bytes).

Another example of a variant branch instruction would be a JMP (A0) instruction. [Figure 19-2](#) shows the outputs of the PST and DDATA signals when a JMP (A0) instruction executed, assuming the CSR is programmed to display the lower two bytes of an address.

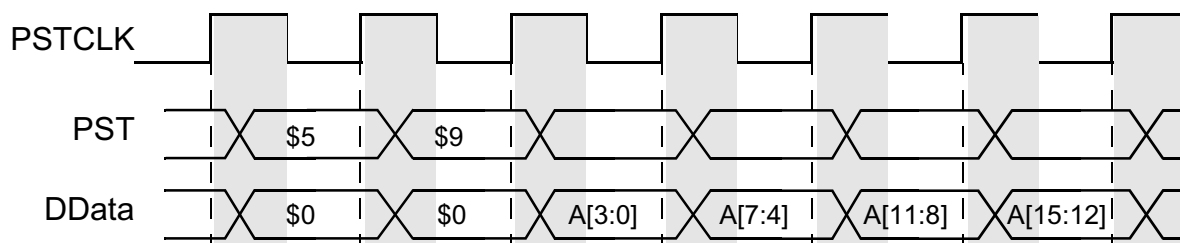

Figure 19-2 Example PST/DDATA Diagram

PST is driven with a \$5 indicating a taken branch. In the second cycle, PST is driven with a marker value of \$9 indicating a two-byte address that is displayed four bits at a time on the DDATA signals over the next four clock cycles. The remaining four clock cycles display the lower two-bytes of the address (A0), least significant nibble to most significant nibble. The output of the PST signals after the JMP instruction completes is dependent on the target instruction. The PST can continue with the next instruction before the address has completely displayed on the DDATA because of the DDATA FIFO. If the FIFO is full and the next instruction needs to display captured values on DDATA, the pipeline stalls (PST = \$0) until space is available in the FIFO.

Freescale Semiconductor, Inc.

Background-Debug Mode (BDM)

19.2.1.6 Begin Execution of RTE Instruction (PST = \$7)

The unique encoding is generated whenever the return-from-exception (RTE) instruction is executed.

19.2.1.7 Begin Data Transfer (PST = \$8–\$B)

These encodings serve as markers to indicate the number of bytes to be displayed on the DDATA port on subsequent clock cycles. This encoding is driven onto the PST port one processor cycle before the actual data is displayed on DDATA. When PST outputs a \$8/\$9/\$A/\$B marker value, the DDATA port outputs 1/2/3/4 bytes of captured data respectively on consecutive processor cycles.

19.2.1.8 Exception Processing (PST = \$C)

This encoding is displayed during normal exception processing. Exceptions which enter emulation mode (debug interrupt, or optionally trace) generate a different encoding. Because this encoding defines a multicycle mode, the PST outputs are driven with this value until exception processing is completed.

19.2.1.9 Emulator Mode Exception Processing (PST = \$D)

This encoding is displayed during emulation mode (debug interrupt, or optionally trace). Because this encoding defines a multicycle mode, the PST outputs are driven with this value until exception processing is completed.

19.2.1.10 Processor Stopped (PST = \$E)

This encoding is generated as a result of the STOP instruction. The ColdFire processor remains in the stopped state until an interrupt occurs. Because this encoding defines a multicycle mode, the PST outputs are driven with this value until the stopped mode is exited.

19.2.1.11 Processor Halted (PST = \$F)

This encoding is generated when the ColdFire processor is halted (Refer to [Section 19.3.1 CPU Halt.](#)) Because this encoding defines a multicycle mode, the PST outputs are driven with this value until the processor is restarted, or reset.

19.3 BACKGROUND-DEBUG MODE (BDM)

Background debug mode (BDM) implements a low-level system debugger in the microprocessor hardware. Communication with the development system is handled through a dedicated, high-speed, full-duplex serial command interface. The BDM features are as follows:

- ColdFire implements the BDM controller in a dedicated hardware module. Although some BDM operations do require the CPU to be halted (For example, CPU register accesses), other BDM commands such as memory accesses can be executed while the processor is running.
- The read/write control register commands, RCREG and WCREG use the register coding scheme from the MOVEC instruction.
- The read/write debug module register commands, RDMREG and WDMREG support debug module register accesses.
- Illegal command responses can be returned using the FILL and DUMP commands, if not immediately preceded by certain, specific BDM commands.
- For any command performing a byte-sized memory read operation, the upper 8 bits of the response data are undefined. The referenced data is returned in the lower 8 bits of the response.
- The debug module forces alignment for memory-referencing operations: long accesses are forced to a 0-modulo-4 address; word accesses are forced to a 0-modulo-2 address. An address error response is never returned.

19.3.1 CPU HALT

Although many BDM operations can occur in parallel with CPU operation, unrestricted BDM operation requires the CPU to be halted. A number of sources can cause the CPU to halt, including the following as shown in order of priority:

1. The occurrence of the catastrophic fault-on-fault condition automatically halts the processor.
2. The occurrence of a hardware breakpoint can be configured to generate a pending halt condition in a manner similar to the assertion of the $\overline{\text{BKPT}}$ signal. In all cases, the assertion of this type of halt is first made pending in the processor. Next, the processor samples for pending halt and interrupt conditions once per instruction. Once the pending condition is asserted, the processor halts execution at the next sample point. See [Section 19.4.1 Theory of Operation](#) for more detail.
3. The execution of the HALT ColdFire instruction immediately suspends execution. By default this is a supervisor instruction and attempted execution while in user mode generates a privilege violation exception. A User Halt Enable (UHE) control bit is provided in the Configuration/Status Register (CSR) to allow execution of HALT in user mode. The processor may be restarted after the execution of the HALT instruction by serial shifting a "GO" command into the debug module. Execution continues at the instruction following the HALT opcode.
4. The assertion of the $\overline{\text{BKPT}}$ input pin is treated as a pseudo-interrupt. For example, the halt condition is made pending until the processor core samples for halts/interrupts. The processor samples for these conditions once during the execution of each instruction. If there is a pending halt condition at the sample time, the processor suspends execution and enters the halted state.

There are two special cases involving the assertion of the $\overline{\text{BKPT}}$ pin to be considered.

After the system reset signal is negated, the processor waits for 16 clock cycles before beginning reset exception processing. If the $\overline{\text{BKPT}}$ input pin is asserted within the first eight cycles after $\overline{\text{RSTI}}$ is negated, the processor enters the halt state, signaling that halt status, (\$F), on the PST outputs. While in this state, all resources accessible through the debug module can be referenced. This is the only opportunity to force the ColdFire processor into emulation mode using the EMU bit in the configuration/status register (CSR). Once the system initialization is complete, the processor response to a BDM GO command is dependent on the set of BDM commands performed while breakpointed. Specifically, if the processor's PC register was loaded, then the GO command simply causes the processor to exit the halted state and pass control to the instruction address contained in the PC.

Note: In this case, the normal reset exception processing is bypassed. Conversely, if the PC register was not loaded, then the GO command causes the processor to exit the halted state and continue with reset exception processing.

ColdFire also handles a special case of the assertion of $\overline{\text{BKPT}}$ while the processor is stopped by execution of the STOP instruction. For this case, the processor exits the stopped mode and enters the halted state. Once halted, all BDM commands may be exercised. When the processor is restarted, it continues with the execution of the next sequential instruction. For example, the instruction following the STOP opcode.

The halt source is indicated in CSR[27:24]. For simultaneous halt conditions, the highest priority source is indicated.

19.3.2 BDM SERIAL INTERFACE

Once the CPU is halted and the halt status reflected on the PST outputs, the development system may send unrestricted commands to the debug module. The debug module implements a synchronous protocol using a three-pin interface: development serial clock (DSCLK), development serial input (DSI), and development serial output (DSO). The development system serves as the serial communication channel

Freescale Semiconductor, Inc.

Background-Debug Mode (BDM)

master and is responsible for generation of the clock (DSCLK). The maximum operating bandwidth of the serial channel is DC to 1/5 of the processor frequency. The channel uses a full duplex mode, where data is transmitted and received simultaneously by both master and slave devices. The transmission consists of 17-bit packets composed of a status/control bit and a 16-bit data word. As shown in [Figure 19-3](#), all state transitions are enabled on a rising edge of the processor clock when DSCLK is high. For example, DSI is sampled and DSO is driven. The DSCLK signal must also be sampled low (on a positive edge of CPUCLK) between each bit exchange. The MSB is transferred first.

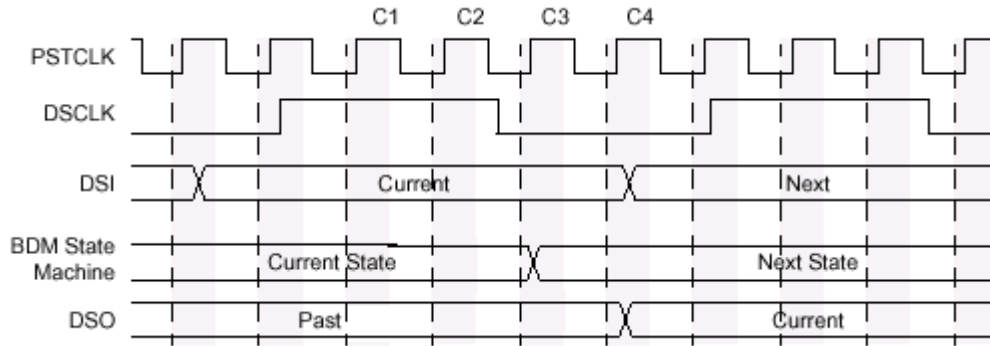

Figure 19-3 BDM Serial Transfer

Both DSCLK and DSI are synchronized inputs. The DSCLK signal essentially acts as a pseudo “clock enable” and is sampled on the rising edge of CPUCLK as well as the DSI. The DSO output is delayed from the DSCLK-enabled CPUCLK rising edge. All events in the debug module’s serial state machine are based on the rising edge of the microprocessor clock).

19.3.2.1 Receive Packet Format

The basic receive packet of information is 17 bits long, 16 data bits plus a status bit, as shown in [Table 19-2](#).

Table 19-2 Receive BDM Packet

16	15	14	13	12	11	10	9	8	7	6	5	4	3	2	1	0
S	DATA FIELD [15:0]															

[Table 19-3](#) describes the receive BDM packets. Bit descriptions are described in [Table 19-4](#).

Table 19-3 CPU-Generated Command Responses

S BIT	DATA	MESSAGE TYPE
0	xxxx	Valid data transfer
0	\$FFFF	Status OK
1	\$0000	Not ready with response; try again
1	\$0001	Error—terminated bus cycle; data invalid
1	\$FFFF	Illegal command

Table 19-4 Receive BDM Bit Descriptions

BIT NAME	DESCRIPTION
S- Status[16]	The status bit indicates the status of CPU-generated messages as shown in Table 19-3 .
Data Field[15:0]	The data field contains the message data to be communicated from the debug module to the development system. The response message is always a single word, with the data field encoded as shown in Table 19-3 .

19.3.2.2 Transmit Packet Format

The basic transmit packet of information is 17 bits long, 16 data bits plus a control bit, as shown in [Table 19-5](#).

Table 19-5 Transmit BDM Packet

16	15	14	13	12	11	10	9	8	7	6	5	4	3	2	1	0
C	DATA FIELD [15:0]															

Table 19-6 Transmit Bit Descriptions

BIT NAME	DESCRIPTION
C-Control [16]	The Control Bit (Bit 16) is reserved. Command and data transfers initiated by the development system should clear bit 16.
Data Field[15:0]	The data field contains the message data to be communicated from the development system to the debug module.

19.3.3 BDM COMMAND SET

ColdFire supports a subset of BDM commands to provide access to new hardware features. The BDM commands must not be issued whenever the ColdFire processor is accessing the debug module registers using the WDEBUG instruction, or the resulting behavior is undefined.

19.3.3.1 BDM Command Set Summary

The BDM command set is summarized in [Table 19-7](#). Subsequent sections contain detailed descriptions of each command.

19.3.3.2 ColdFire BDM Commands

All ColdFire Family BDM commands include a 16-bit operation word followed by an optional set of one or more extension words as shown in [Table 19-8](#).

Table 19-7 BDM Command Summary

COMMAND	MNEMONIC	DESCRIPTION	CPU IMPACT ¹	COMMAND (HEX)	PAGE
READ A/D REGISTER	RAREG/RDREG	Read the selected address or data register and return results through the serial interface.	Halted	\$218 {A/D, Reg[2:0]}	19-13
WRITE A/D REGISTER	WAREG/WDREG	The data operand is written to the specified address or data register.	Halted	\$208 {A/D, Reg[2:0]}	19-13
READ MEMORY LOCATION	READ	Read the data at the memory location specified by the longword address.	Steal	\$1900—byte \$1940—wd \$1980—long	19-14
WRITE MEMORY LOCATION	WRITE	Write the operand data to the memory location specified by the longword address.	Steal	\$1800—byte \$1840—wd \$1880—long	19-16
DUMP MEMORY BLOCK	DUMP	Used with the READ command to dump large blocks of memory. An initial READ is executed to set up the starting address of the block and to retrieve the first result. Subsequent operands are retrieved with the DUMP command.	Steal	\$1D00—byte \$1D40—wd \$1D80—long	19-17
FILL MEMORY BLOCK	FILL	Used with the WRITE command to fill large blocks of memory. An initial WRITE is executed to set up the starting address of the block and to supply the first operand. Subsequent operands are written with the FILL command.	Steal	\$1C00—byte \$1C40—word \$1C80—long	19-18
RESUME EXECUTION	GO	The pipeline is flushed and refilled before execution resumes at the current PC.	Halted	\$0C00	19-20
NO OPERATION	NOP	NOP performs no operation and may be used as a null command.	Parallel	\$0000	19-20
READ CONTROL REGISTER	RCREG	Read the system control register.	Halted	\$2980	19-21
WRITE CONTROL REGISTER	WCREG	Write the operand data to the system control register.	Halted	\$2880	19-22
READ DEBUG MODULE REGISTER	RDMREG	Read the debug module register.	Parallel	\$2D {\$4† DRc[4:0]}	19-22
WRITE DEBUG MODULE REGISTER	WDMREG	Write the operand data to the debug module register.	Parallel	\$2C {\$4† Drc[4:0]}	19-23

NOTE: General command effect and/or requirements on CPU operation:
 Halted—The CPU must be halted to perform this command
 Steal—Command generates bus cycles which can be interleaved with CPU accesses
 Parallel—Command is executed in parallel with CPU activity
 Refer to command summaries for detailed operation descriptions.

Table 19-8 BDM Command Format

15	14	13	12	11	10	9	8	7	6	5	4	3	2	1	0
OPERATION						0	R/W	OP SIZE		0	0	A/D	REGISTER		
EXTENSION WORD(S)															

Table 19-9 describes the BDM bit fields.

Table 19-9 BDM Bit Descriptions

BIT NAME	DESCRIPTION
Operation Field	The operation field specifies the command.
R/W Field	The R/W field specifies the direction of operand transfer. When the bit is set, the transfer is from the CPU to the development system. When the bit is cleared, data is written to the CPU or to memory from the development system.
Operand Size	For sized operations, this field specifies the operand data size. All addresses are expressed as 32-bit absolute values. The size field is encoded as listed in Table 19-10.
Address / Data (A/D) Field	The A/D field is used in commands that operate on address and data registers in the processor. It determines whether the register field specifies a data or address register. A one indicates an address register; zero, a data register.
Register Field	In commands that operate on processor registers, this field specifies which register is selected. The field value contains the register number.
Extension Word(s) (as required)	Certain commands require extension words for addresses and/or immediate data. Addresses require two extension words because only absolute long addressing is permitted. Immediate data can be either one or two words in length—byte and word data each require a single extension word; longword data requires two words. Both operands and addresses are transferred most significant word first. In the following descriptions of the BDM command set, the optional set of extension words is defined as “Address,” “Data,” or “Operand Data.”

Table 19-10 BDM Size Field Encoding

ENCODING	OPERAND SIZE	BIT VALUES
00	Byte	8 bits
01	Word	16 bits
10	Longword	32 bits
11	Reserved	

19.3.3.3 Command Sequence Diagram

A command sequence diagram (see Figure 19-4) shows the serial bus traffic for each command. Each bubble in the diagram represents a single 17-bit transfer across the bus. The top half in each bubble corresponds to the data transmitted by the development system to the debug module; the bottom half

Freescale Semiconductor, Inc.

Background-Debug Mode (BDM)

corresponds to the data returned by the debug module in response to the previous development system commands. Command and result transactions are overlapped to minimize latency.

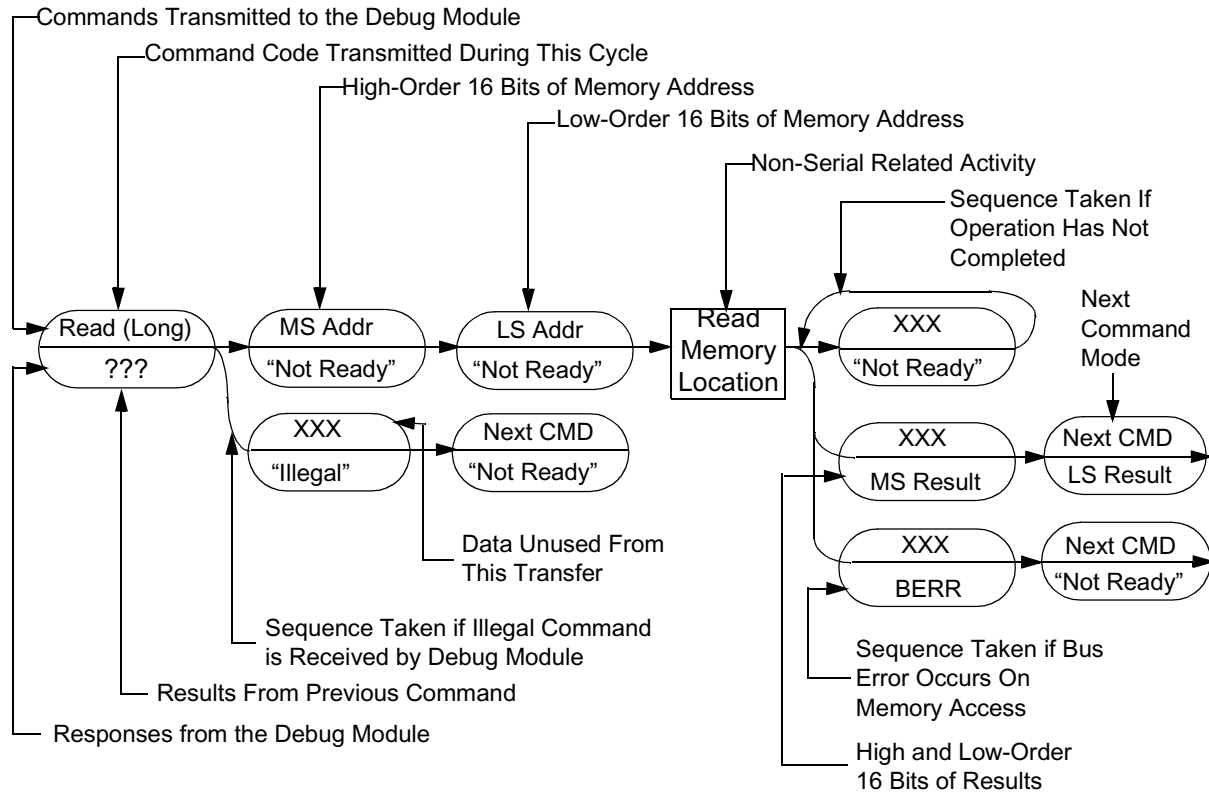

Figure 19-4 Command Sequence Diagram

The cycle in which the command is issued contains the development system command mnemonic (in this example, “read memory location”). During the same cycle, the debug module responds with either the low-order results of the previous command or a command complete status (if no results were required).

During the second cycle, the development system supplies the high-order 16 bits of the memory address. The debug module returns a “not ready” response unless the received command was decoded as unimplemented, in which case the response data is the illegal command encoding. If an illegal command response occurs, the development system should retransmit the command.

Note: The “not ready” response can be ignored unless a memory-referencing cycle is in progress. Otherwise, the debug module can accept a new serial transfer after 32 processor clock periods.

In the third cycle, the development system supplies the low-order 16 bits of a memory address. The debug module always returns the “not ready” response in this cycle. At the completion of the third cycle, the debug module initiates a memory read operation. Any serial transfers that begin while the memory access is in progress return the “not ready” response.

Results are returned in the two serial transfer cycles following the completion of the memory access. The data transmitted to the debug module during the final transfer is the opcode for the following command. If a memory or register access is terminated with a bus error, the error status (S=1, DATA=\$0001) is returned in place of the result data.

19.3.3.4 Command Set Descriptions

The BDM command set is summarized in [Table 19-7](#). Subsequent sections contain detailed descriptions of each command.

Note: The BDM status bit (S) is zero for normally-completed commands, while illegal commands, “not ready” responses and bus-error transfers return a logic one in the S bit. Refer to [Section 19.3.2 BDM Serial Interface](#) for information on the serial packet receive packet format

Unassigned command opcodes are reserved by Motorola for future expansion. All unused command formats within any revision level perform a NOP and return the ILLEGAL command response.

19.3.3.4.1 Read Address/Data Register (RAREG/RDREG)

RAREG and RDREG reads the selected address or data register and return the 32-bit result. A bus error response is returned if the CPU core is not halted.

	15	12	11	8	7	4	3	2	0
Command	0x2		0x1		0x8		A/D	Register	
Result	D[31:16]								
	D[15:0]								

Figure 19-5 Command/Result Formats

Command Sequence:

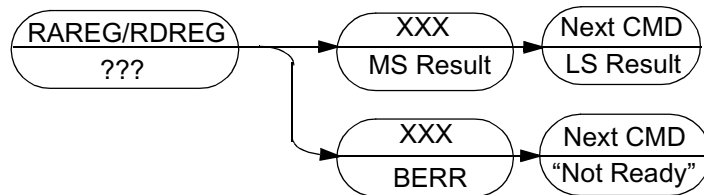

Figure 19-6 Read A/D Register Command Sequence

“Operand Data”

None

“Result Data”

The contents of the selected register are returned as a longword value. The data is returned most significant word first.

19.3.3.4.2 Write Address/Data Register (WAREG and WDREG)

WAREG and WDREG write the operand longword data to the specified address or data register. All 32 register bits are altered by the write. A bus error response is returned if the CPU core is not halted.

Freescale Semiconductor, Inc.

Background-Debug Mode (BDM)

Command Format:

Table 19-11 WAREG/WDREG Command

15	14	13	12	11	10	9	8	7	6	5	4	3	2	1	0
\$2				\$0				\$8				A/D	REGISTER		
DATA [31:16]															
DATA [15:0]															

Command Sequence:

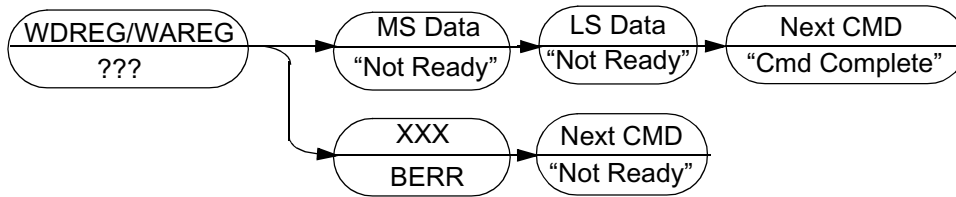

Figure 19-7 Write A/D Register Command Sequence

Operand Data

Longword data is written into the specified address or data register. The data is supplied most significant word first.

Result Data

Command complete status is indicated by returning the data \$FFFF (with the status bit cleared) when the register write is complete.

19.3.3.4.3 Read Memory Location (READ)

The READ command reads the operand data from the memory location specified by the longword address. The address space is defined by the contents of the low-order 5 bits {TT, TM} of the BDM Address Attribute Register (BAAR). The hardware forces the low-order bits of the address to zeros for word and longword accesses to ensure that operands are always accessed on natural boundaries: words on 0-modulo-2 addresses, longwords on 0-modulo-4 addresses.

15	12	11	8	7	4	3	2	0		
0x2			0x0			0x8			A/D	Register
D[31:16]										
D[15:0]										

Figure 19-8 WAREG/WDREG Command Format

		15	12	11	8	7	4	3	0	
Byte	Command	0x1			0x9			0x0		0x0
		A[31:16]								
		A[15:0]								
	Result	X	X	X	X	X	X	X	D[7:0]	
Word	Command	0x1			0x9			0x4		0x0
		A[31:16]								
		A[15:0]								
	Result	D[15:0]								
Longword	Command	0x1			0x9			0x8		0x0
		A[31:16]								
		A[15:0]								
	Result	D[31:16]					D[15:0]			

Figure 19-9 READ Command/Result Format

Command Sequence:

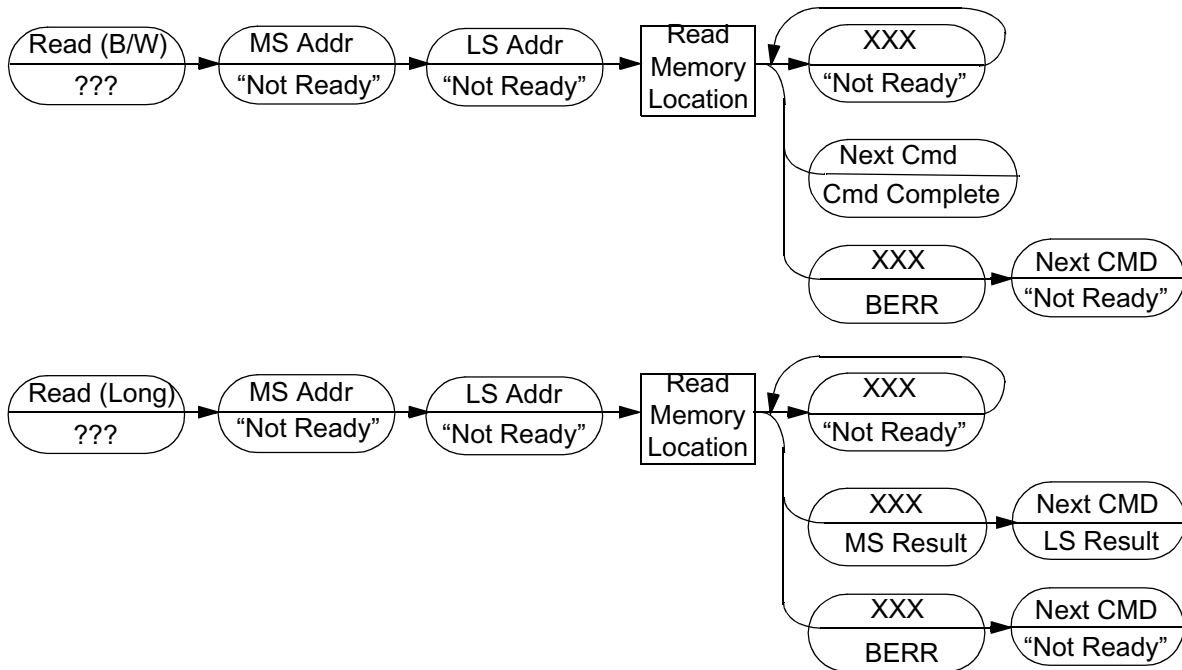

Figure 19-10 Read Memory Location Command Sequence

“Operand Data”

The single operand is the longword address of the requested memory location.

Freescale Semiconductor, Inc.

Background-Debug Mode (BDM)

“Result Data”

The requested data is returned as either a word or longword. Byte data is returned in the least significant byte of a word result, with the upper byte undefined. Word results return 16 bits of significant data; longword results return 32 bits. A value of \$0001 (with the status bit set) is returned if a bus error occurs.

19.3.3.4.4 Write Memory Location (WRITE)

The WRITE command writes the operand data to the memory location specified by the longword address. The address space is defined by the contents of the low-order 5 bits {TT, TM} of the BDM Address Attribute Register (BAAR). The hardware forces the low-order bits of the address to zeros for word and longword accesses to ensure that operands are always accessed on natural boundaries: words on 0-modulo-2 addresses, longwords on 0-modulo-4 addresses.

Command Sequence:

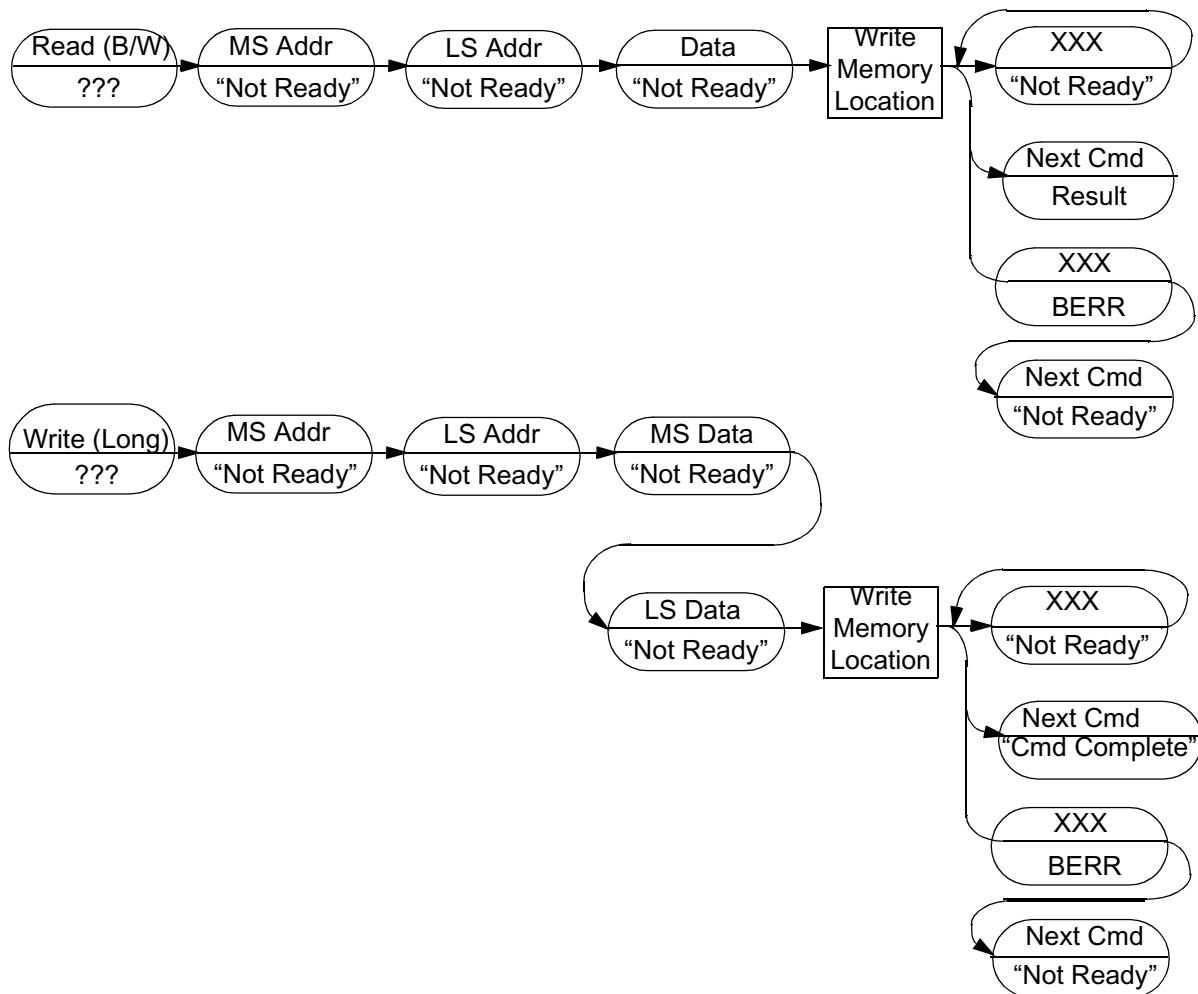

Figure 19-11 Write Memory Location Command Sequence

Operand Data:

Two operands are required for this instruction. The first operand is a longword absolute address that specifies a location to which the operand data is to be written. The second operand is the data. Byte data is transmitted as a 16-bit word, justified in the least significant byte; 16- and 32-bit operands are transmitted as 16 and 32 bits, respectively.

Result Data:

Command complete status is indicated by returning the data \$FFFF (with the status bit cleared) when the register write is complete. A value of \$0001 (with the status bit set) is returned if a bus error occurs.

19.3.3.4.5 Dump Memory Block (DUMP)

DUMP is used in conjunction with the READ command to access large blocks of memory. An initial READ is executed to set up the starting address of the block and to retrieve the first result. The DUMP command retrieves subsequent operands. The initial address is incremented by the operand size (1, 2, or 4) and saved in a temporary register. Subsequent DUMP commands use this address, perform the memory read, increment it by the current operand size, and store the updated address in the temporary register.

Note: The DUMP command does not check for a valid address. DUMP is a valid command only when preceded by another DUMP, NOP, or by a READ command. Otherwise, an illegal command response is returned. The NOP command can be used for intercommand padding without corrupting the address pointer.

The size field is examined each time a DUMP command is processed, allowing the operand size to be dynamically altered.

	15	12	11	8	7	4	3	1
Byte	0x1		0x8			0x0		0x0
	A[31:16]							
	A[15:0]							
	X	X	X	X	X	X	X	D[7:0]
Word	0x1		0x8			0x4		0x0
	A[31:16]							
	A[15:0]							
	D[15:0]							
Longword	0x1		0x8			0x8		0x0
	A[31:16]							
	A[15:0]							
	D[31:16]							
	D[15:0]							

Figure 19-12 DUMP Command/Result Format

Freescale Semiconductor, Inc.

Background-Debug Mode (BDM)

Command Sequence

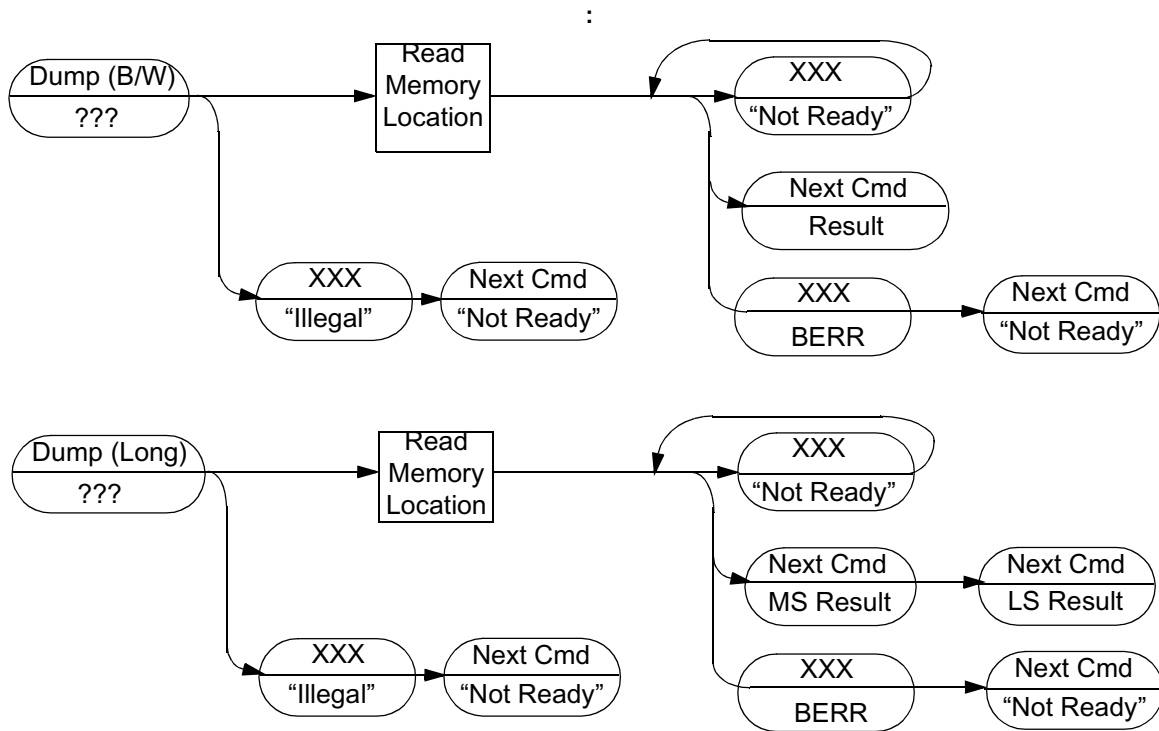

Figure 19-13 DUMP Memory Block Command Sequence

“Operand Data”:

None

“Result Data:”

Requested data is returned as either a word or longword. Byte data is returned in the least significant byte of a word result. Word results return 16 bits of significant data; longword results return 32 bits. A value of \$0001 (with the status bit set) is returned if a bus error occurs.

19.3.3.4.6 Fill Memory Block (FILL)

FILL is used in conjunction with the WRITE command to access large blocks of memory. An initial WRITE is executed to set up the starting address of the block and to supply the first operand. The FILL command writes subsequent operands. The initial address is incremented by the operand size (1, 2, or 4) and saved in a temporary register after the memory write. Subsequent FILL commands use this address, perform the write, increment it by the current operand size, and store the updated address in the temporary register.

Note: The FILL command does not check for a valid address FILL is a valid command only when preceded by another FILL, NOP or by a WRITE command. Otherwise, an illegal command response is returned. The NOP command can be used for intercommand padding without corrupting the address pointer.

The size field is examined each time a FILL command is processed, allowing the operand size to be altered dynamically.

Command Formats:

Table 19-12 Byte FILL Command

15	14	13	12	11	10	9	8	7	6	5	4	3	2	1	0
\$1				\$C				\$0				\$0			
X	X	X	X	X	X	X	X	DATA [7:0]							

Table 19-13 Word FILL Command

15	14	13	12	11	10	9	8	7	6	5	4	3	2	1	0
\$1				\$C				\$4				\$0			
DATA [15:0]															

Table 19-14 Long FILL Command

15	14	13	12	11	10	9	8	7	6	5	4	3	2	1	0
\$1				\$C				\$8				\$0			
DATA [31:16]															
DATA [15:0]															

Command Sequence:

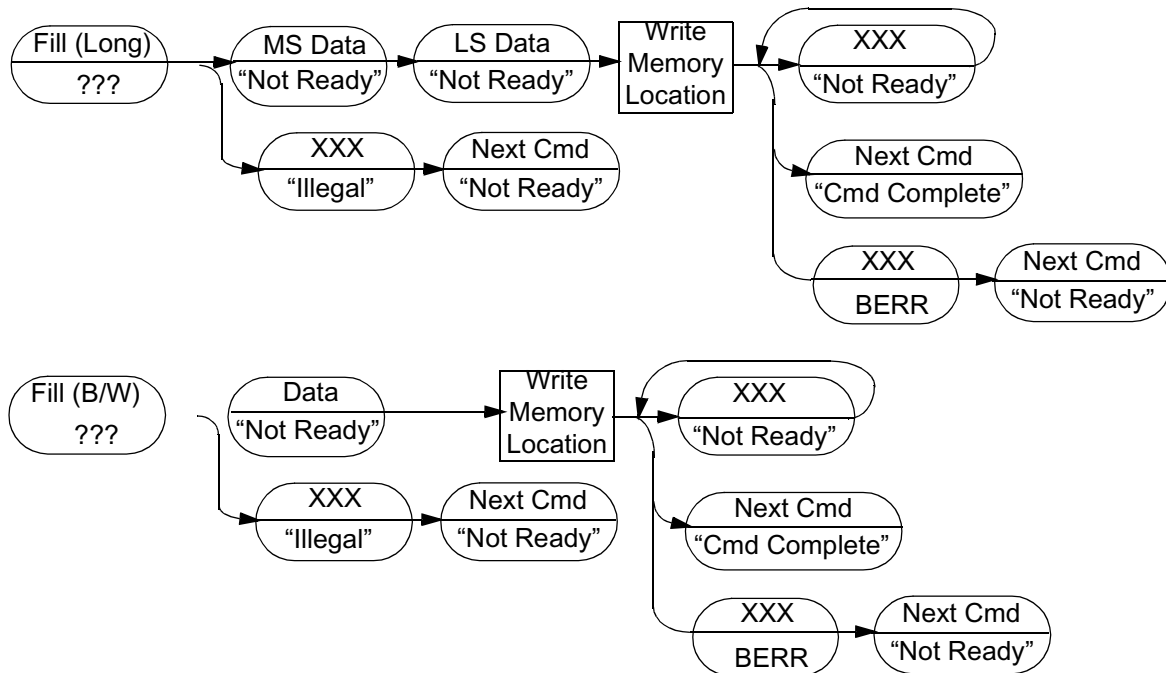

Figure 19-14 Fill Memory Block Command Sequence

Freescale Semiconductor, Inc.

Background-Debug Mode (BDM)

Operand Data:

A single operand is data to be written to the memory location. Byte data is transmitted as a 16-bit word, justified in the least significant byte; 16- and 32-bit operands are transmitted as 16 and 32 bits, respectively.

Result Data:

Command complete status is indicated by returning the data \$FFFF (with the status bit cleared) when the register write is complete. A value of \$0001 (with the status bit set) is returned if a bus error occurs.

19.3.3.4.7 Resume Execution (GO)

The GO command flushes and refills the pipeline before resuming normal instruction execution. Prefetching begins at the current PC and current privilege level. If any register (For example, the PC or SR) was altered by a BDM command while halted, the updated value is used as the prefetching resumes.

Command Formats:

Table 19-15 GO Command

15	14	13	12	11	10	9	8	7	6	5	4	3	2	1	0
\$0				\$C				\$0				\$0			

Command Sequence:



Figure 19-15 Resume Execution

Operand Data:

None

Result Data:

The "command complete" response (\$0FFFF) is returned during the next shift operation.

19.3.3.4.8 No Operation (NOP)

NOP performs no operation and may be used as a null command where required.

Command Formats:

Table 19-16 NOP Command

15			12	11			8	7			4	3			0
\$0				\$0				\$0				\$0			

Command Sequence:



Figure 19-16 No Operation Command Sequence

“Operand Data”:

None

“Result Data”:

The “command complete” response, \$FFFF (with the status bit cleared), is returned during the next shift operation.

19.3.3.4.9 Read Control Register (RCREG)

RCREG reads the selected control register and returns the 32-bit result. Accesses to the processor/memory control registers are always 32 bits in size, regardless of the implemented register width. The second and third words of the command effectively form a 32-bit address used by the debug module to generate a special bus cycle to access the specified control register. The 12-bit Rc field is the same as that used by the MOVEC instruction.

	15	12	11	8	7	4	3	0
Command	0x2		0x9		0x8		0x0	
	0x0		0x0		0x0		0x0	
	0x0		Rc					
Result	D[31:16]							
	D[15:0]							

Figure 19-17 RCREG Command/Result Formats

Table 19-17 RC Encoding

Rc	REGISTER DEFINITION
\$002	Cache Control Register (CACR)
\$004	Access Control Register 0 (ACR0)
\$005	Access Control Register 1 (ACR1)
\$801	Vector BASE Register (VBR)
\$804	MAC Status Register (MACSR)
\$805	MAC Mask Register (MASK)
\$806	MAC Accumulator (ACC0)
\$807	MAC Accumulator (ACC1)
\$808	MAC Accumulator (ACC2)
\$80B	MAC Accumulator (ACC3)
\$80E	Status Register (SR)
\$80F	Program Register (PC)
\$C04	RAM Base Address Register (RAMBAR0)
\$C05	RAM Base Address Register (RAMBAR1)
\$C0F	Module Base Address Register (MBAR)
\$C0E	Module Base Address Register (MBAR2)

Freescale Semiconductor, Inc.

Background-Debug Mode (BDM)

19.3.3.4.10 Write Control Register (WCREG)

The operand (longword) data is written to the specified control register. The write alters all 32 register bits.

	15	12	11	8	7	4	3	0
Command	0x2		0x8		0x8		0x0	
	0x0		0x0		0x0		0x0	
	0x0		Rc					
Result	D[31:16]							
	D[15:0]							

Figure 19-18 WCREG Command Sequence

Command Sequence

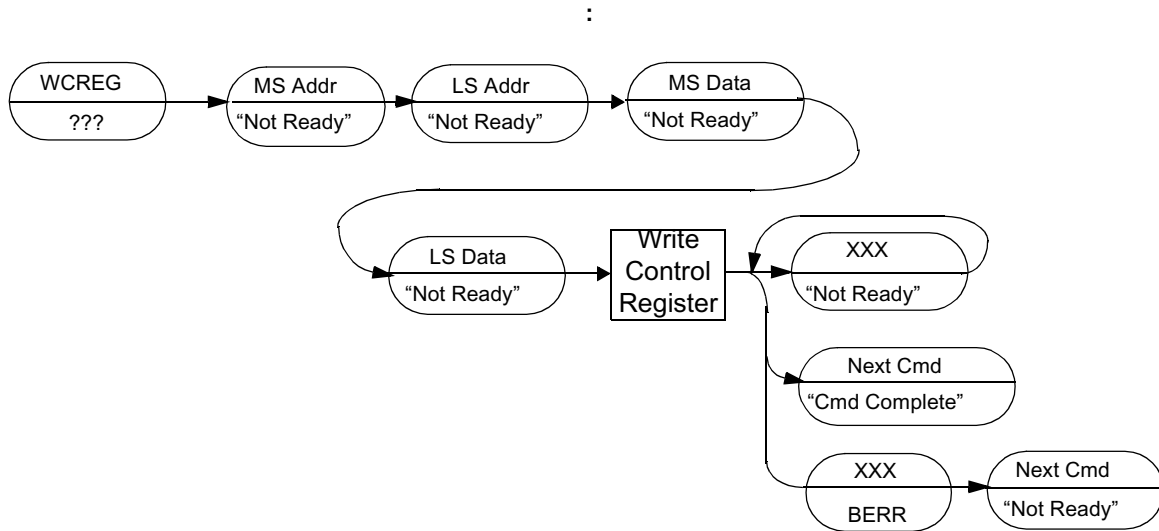

Figure 19-19 Write Control Register Command Sequence

Operand Data:

Two operands are required for this instruction. The first long operand selects the register to which the operand data is to be written. The second operand is the data.

Result Data:

Successful write operations return a \$FFFF. Bus errors on the write cycle are indicated by the assertion of bit 16 in the status message and by a data pattern of \$0001.

19.3.3.4.11 Read Debug Module Register (RDMREG)

RDMREG reads the selected debug module register and return the 32-bit result. The only valid register selection for the RDMREG command is the CSR (DRc = \$0).

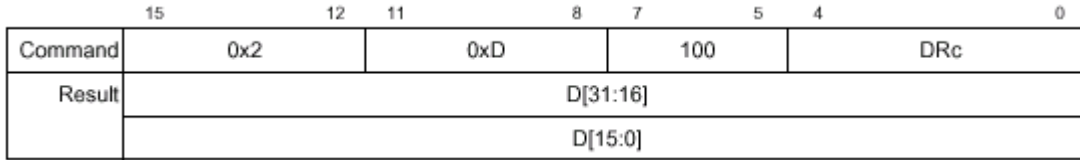

Figure 19-20 RDMREG Command/Result Formats

DRc encoding:

Table 19-18 Definition of DRc Encoding--Read

DRc[3:0]	DEBUG REGISTER DEFINITION	MNEMONIC	INITIAL STATE
\$0	Configuration/Status	CSR	\$0
\$1-\$F	Reserved	-	-

Command Sequence

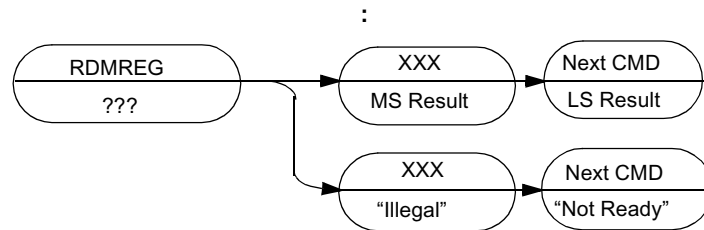

Figure 19-21 Read Debug Module Register Command Sequence

Operand Data:

None

Result Data:

The contents of the selected debug register are returned as a longword value. The data is returned most significant word first.

19.3.3.4.12 Write Debug Module Register (WDMREG)

The operand (longword) data is written to the specified debug module register. All 32 bits of the register are altered by the write. The DSCLK signal must be inactive while debug module register writes from the CPU accesses are performed using the WDEBUG instruction.

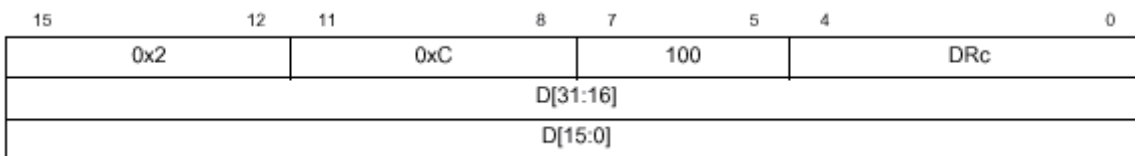

Figure 19-22 WDMREG BDM Command Format

DRc encoding

Table 19-19 Definition of DRc Encoding--Write

DRc[3:0]	DEBUG REGISTER DEFINITION	MNEMONIC	INITIAL STATE
\$0	Configuration/Status	CSR	\$0
\$1-\$4	Reserved	-	-
\$5	BDM Address Attribute	BAAR	\$5
\$6	Bus Attributes and Mask	AATR	\$5
\$7	Trigger Definition	TDR	\$0
\$8	PC Breakpoint	PBR	-
\$9	PC Breakpoint Mask	PBMR	-
\$A-\$B	Reserved	-	-
\$C	Operand Address High Breakpoint	ABHR	-
\$D	Operand Address Low Breakpoint	ABLR	-
\$E	Data Breakpoint	DBR	-
\$F	Data Breakpoint Mask	DBMR	-

Command Sequence:

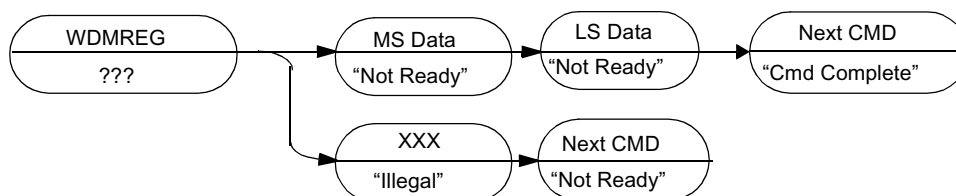

Figure 19-23 Write Debug Module Register Command Sequence

Operand Data:

Longword data is written into the specified debug register. The data is supplied most significant word first.

Result Data:

Command complete status (\$0FFFF) is returned when register write is complete.

19.3.3.4.13 Unassigned Opcodes

Unassigned command opcodes are reserved by Motorola. All unused command formats within any revision level perform a NOP and return the ILLEGAL command response.

19.3.3.5 BDM Accesses of the EMAC Registers

The presence of rounding logic in the output data path of the EMAC requires special care for BDM-initiated reads and writes of its programming model. In particular, any result rounding modes must be disabled during the read/write process so the exact bit-wise EMAC register contents are accessed. For example, a BDM read of an accumulator (ACCx) requires the following sequence:

```

Bdm Read ACCx (
rcreg macsr; // read current macsr contents & save
wcreg #0,macsr; // disable all rounding modes
rcreg ACCx; // read the desired accumulator
wcreg #saved_data,macsr; // restore the original macsr
)
    
```

Likewise to write an accumulator register, the following BDM sequence is needed:

```

Bdm Write ACCx (
rcreg macsr; // read current macsr contents & save
wcreg #0,macsr; // disable all rounding modes
wcreg #data,ACCx; // write the desired accumulator
wcreg #saved_data,macsr; // restore the original macsr
)
    
```

Additionally, writes to the accumulator extension registers must be performed after the corresponding accumulators are updated because a write to any accumulator alters the corresponding extension register contents.

Command Sequence:

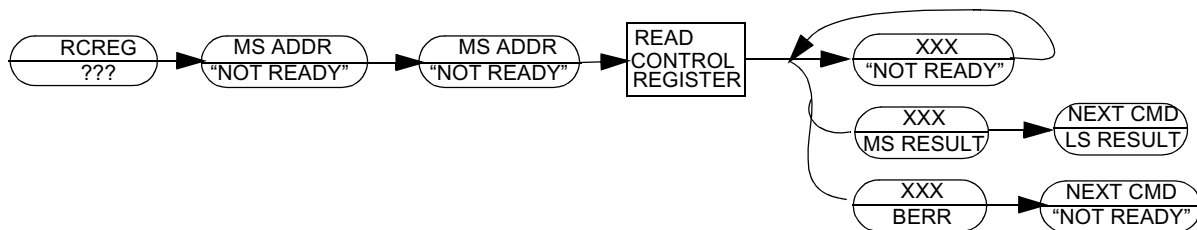

Figure 19-24 Read Control Register Command Sequence

Operand Data:

The single operand is the 32-bit Rc control register select field.

Result Data:

The contents of the selected control register are returned as a longword value. The data is returned most significant word first. For those control registers with widths less than 32 bits, only the implemented portion of the register is guaranteed to be correct. The remaining bits of the longword are undefined.

19.4 REAL-TIME DEBUG SUPPORT

The ColdFire Family provides support for the debug of real-time applications. For these types of embedded systems, the processor cannot be halted during debug, but must continue to operate. The foundation of this area of debug support is that while the processor cannot be halted to allow debugging, the system can generally tolerate small intrusions into the real-time operation.

The debug module provides a number of hardware resources to support various hardware breakpoint functions. Specifically, three types of breakpoints are supported: PC with mask, operand address range, and data with mask. These three basic breakpoints can be configured into one- or two-level triggers with the exact trigger response also programmable. The debug module programming model is accessible from

either the external development system using the serial interface or from the processor's supervisor programming model using the WDEBUG instruction.

19.4.1 THEORY OF OPERATION

The breakpoint hardware can be configured to respond to triggers in several ways. The desired response is programmed into the Trigger Definition Register (TDR). In all situations where a breakpoint triggers, an indication is provided on the DDATA output port, when not displaying captured operands or branch addresses, as shown in [Table 19-20](#).

Table 19-20 DDATA[3:0], CSR[31:28] Breakpoint Response

DDATA[3:0], CSR[31:28]	BREAKPOINT STATUS
\$000x	No Breakpoints Enabled
\$001x	Waiting for Level 1 Breakpoint
\$010x	Level 1 Breakpoint Triggered
\$101x	Waiting for Level 2 Breakpoint
\$110x	Level 2 Breakpoint Triggered
All other encodings are reserved for future use.	

The breakpoint status is also posted in the CSR.

The BDM instructions load and configure the desired breakpoints using the appropriate registers. As the system operates, a breakpoint trigger generates a response as defined in the TDR. If the system can tolerate the processor being halted, a BDM-entry can be used. With the TRC bits of the TDR equal to \$1, the breakpoint trigger causes the core to halt as reflected in the PST = \$F status.

Note: For PC breakpoints, the halt occurs before the targeted instruction is executed. For address and data breakpoints, the processor may have executed several additional instructions. As a result, trigger reporting is considered imprecise.

If the processor core cannot be halted, the special debug interrupt can be used. With this configuration, TRC bits of the TDR equal to \$2, the breakpoint trigger is converted into a debug interrupt to the processor. This interrupt is treated higher than the nonmaskable level 7 interrupt request. As with all interrupts, it is made pending until the processor reaches a sample point, which occurs once per instruction. Again, the hardware forces the PC breakpoint to occur immediately (before the execution of the targeted instruction). This is possible because the PC breakpoint comparison is enabled at the same time the interrupt sampling occurs. For the address and data breakpoints, the reporting is considered imprecise because several additional instructions may be executed after the triggering address or data is seen.

Once the debug interrupt is recognized, the processor aborts execution and initiates exception processing. At the initiation of the exception processing, the core enters emulator mode. After the standard 8-byte exception stack is created, the processor fetches a unique exception vector, 12, from the vector table (Refer to the ColdFire Programmer's Reference Manual).

Execution continues at the instruction address contained in this exception vector. All interrupts are ignored while in emulator mode. Users can program the debug-interrupt handler to perform the necessary context saves using the supervisor instruction set. As an example, this handler may save the state of all the program-visible registers as well as the current context into a reserved memory area.

Once the required operations are completed, the return-from-exception (RTE) instruction is executed and the processor exits emulator mode. Once the debug interrupt handler has completed its execution, the external development system can then access the reserved memory locations using the BDM commands to read memory.

Prior to the Rev. A implementation, if a hardware breakpoint (For example, a PC trigger) is left unmodified by the debug interrupt service routine, another debug interrupt is generated after the RTE instruction completes execution. In the Rev. A design, the hardware has been modified to inhibit the generation of another debug interrupt during the first instruction after the RTE exits emulator mode. This behavior is consistent with the existing logic involving trace mode, where the execution of the first instruction occurs before another trace exception is generated. This Rev. A enhancement disables all hardware breakpoints until the first instruction after the RTE has completed execution, regardless of the programmed trigger response.

19.4.1.1 Emulator Mode

Emulator mode is used to facilitate non-intrusive emulator functionality. This mode can be entered in three different ways:

- The EMU bit in the CSR may be programmed to force the ColdFire processor to begin execution in emulator mode. This bit is only examined when $\overline{\text{RSTI}}$ is negated and the processor begins reset exception processing. It may be set while the processor is halted before the reset exception processing begins. Refer to [Section 19.3.1 CPU Halt](#).
- A debug interrupt always enters emulation mode when the debug interrupt exception processing begins.
- The TCR bit in the CSR may be programmed to force the processor into emulation mode when trace exception processing begins.

During emulation mode, the ColdFire processor exhibits the following properties:

- All interrupts are ignored, including level seven.
- If the MAP bit of the CSR is set, all memory accesses are forced into a specially mapped address space signalled by TT = \$2, TM = \$5 or \$6. This includes the stack frame writes and the vector fetch for the exception which forced entry into this mode.
- If the MAP bit in the CSR is set, all caching of memory accesses is disabled. Additionally, the SRAM module is disabled while in this mode.

The return-from-exception (RTE) instruction exits emulation mode. The processor status output port provides a unique encoding for emulator mode entry (\$D) and exit (\$7).

19.4.1.2 Debug Module Hardware

19.4.1.2.1 Reuse of Debug Module Hardware (Rev. A)

The debug module implementation provides a common hardware structure for both BDM and breakpoint functionality. Several structures are used for both BDM and breakpoint purposes. [Table 19-21](#) identifies the shared hardware structures.

The shared use of these hardware structures means the loading of the register to perform any specified function is destructive to the shared function. For example, if an operand address breakpoint is loaded into the debug module, a BDM command to access memory overwrites the breakpoint. If a data breakpoint is configured, a BDM write command overwrites the breakpoint contents.

Table 19-21 Shared BDM/Breakpoint Hardware

REGISTER	BDM FUNCTION	BREAKPOINT FUNCTION
AATR	Bus Attributes for All Memory Commands	Attributes for Address Breakpoint
ABHR	Address for All Memory Commands	Address for Address Breakpoint
DBR	Data for All BDM Write Commands	Data for Data Breakpoint

19.4.2 PROGRAMMING MODEL

In addition to the existing BDM commands that provide access to the processor’s registers and the memory subsystem, the debug module contains nine registers to support the required functionality. All of these registers are treated as 32-bit quantities, regardless of the actual number of bits in the implementation. The registers, known as the debug control registers, are accessed through the BDM port using two new BDM commands: WDMREG and RDMREG. These commands contain a 4-bit field, DRc, which specifies the particular register being accessed.

These registers are also accessible from the processor’s supervisor programming model through the execution of the WDEBUG instruction. Thus, the breakpoint hardware within the debug module may be accessed by the external development system using the serial interface, or by the operating system running on the processor core. It is the responsibility of the software to guarantee that all accesses to these resources are serialized and logically consistent. The hardware provides a locking mechanism in the CSR to allow the external development system to disable any attempted writes by the processor to the breakpoint registers (setting IPW = 1). The BDM commands must not be issued if the ColdFire processor is accessing the debug module registers using the WDEBUG instruction.

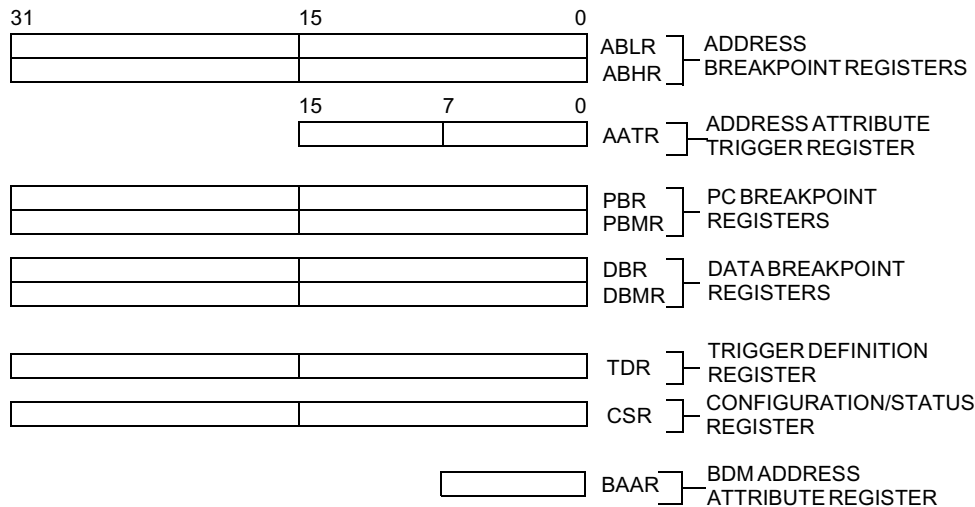

Figure 19-25 Debug Programming Mode

19.4.2.1 Address Breakpoint Registers

The address breakpoint registers (ABLR and ABHR) define a region in the operand address space of the processor that can be used as part of the trigger. The full 32-bits of the ABLR and ABHR values are compared with the address for all transfers on the processor’s high-speed local bus. The trigger definition register (TDR) determines if the trigger is the inclusive range bound by ABLR and ABHR, all addresses

outside this range, or the address in ABLR only. The ABHR is accessible in supervisor mode as debug control register \$C using the WDEBUB instruction and through the BDM port using the RDMREG and WDMREG commands. The ABLR is accessible in supervisor mode as debug control register \$D using the WDEBUB instruction and through the BDM port using the WDMREG commands. The ABHR is overwritten by the BDM hardware when accessing memory as described in [Section 19.4.1.2 Debug Module Hardware](#).

Table 19-22 Address Breakpoint Low Register (ABLR)

BITS	31	30	29	28	27	26	25	24	23	22	21	20	19	18	17	16
FIELD	ADDRESS[31:0]															
RESET	-	-	-	-	-	-	-	-	-	-	-	-	-	-	-	-
R/W	WRITE ONLY															
ADDR																
BITS	15	14	13	12	11	10	9	8	7	6	5	4	3	2	1	0
FIELD	ADDRESS[31:0]															
RESET	-	-	-	-	-	-	-	-	-	-	-	-	-	-	-	-
R/W	WRITE ONLY															

ADDRESS[31:0]—Low Address

This field contains the 32-bit address which marks the lower bound of the address breakpoint range. Additionally, if a breakpoint on a specific address is required, the value is programmed into the ABLR.

Table 19-23 Address Breakpoint High Register (ABHR)

BITS	31	30	29	28	27	26	25	24	23	22	21	20	19	18	17	16
FIELD	ADDRESS[31:0]															
RESET	-	-	-	-	-	-	-	-	-	-	-	-	-	-	-	-
R/W	WRITE ONLY															
BITS	15	14	13	12	11	10	9	8	7	6	5	4	3	2	1	0
FIELD	ADDRESS[31:0]															
RESET	-	-	-	-	-	-	-	-	-	-	-	-	-	-	-	-
R/W	WRITE ONLY															

ADDRESS[31:0]—High Address

This field contains the 32-bit address which marks the upper bound of the address breakpoint range.

19.4.2.2 Address Attribute Trigger Register

The AATR defines the address attributes and a mask to be matched in the trigger. The AATR value is compared with the address attribute signals from the processor’s local high-speed bus, as defined by the setting of the TDR. The AATR is accessible in supervisor mode as debug control register \$6 using the WDEBUB instruction and through the BDM port using the WDMREG command. The lower five bits of the AATR are also used for BDM command definition to define the address space for memory references as described in [Section 19.4.1.2 Debug Module Hardware](#).

Table 19-24 Address Attribute Trigger Register (AATR)

BITS	15	14	13	12	11	10	9	8	7	6	5	4	3	2	1	0
FIELD	RM	SZM		TTM		TMM			R	SZ		TT		TM		
RESET	0	0	0	0	0	0	0	0	0	0	0	0	0	1	0	1
R/W	WRITE ONLY															
ADDR																

Table 19-25 Address Attribute Trigger Bit Descriptions

BIT NAME	DESCRIPTION
RM[15]	The Read/Write Mask field corresponds to the R-field. Setting this bit causes R to be ignored in address comparisons.
SZM[14:13]	The Size Mask field corresponds to the SZ field. Setting a bit in this field causes the corresponding bit in SZ to be ignored in address comparisons.
TTM[12:11]	The Transfer Type Mask field corresponds to the TT field. Setting a bit in this field causes the corresponding bit in TT to be ignored in address comparisons.
TMM[10:8]	The Transfer Modifier Mask field corresponds to the TM field. Setting a bit in this field causes the corresponding bit in TM to be ignored in address comparisons.
R [7]	The Read/Write field is compared with the R?W signal of the processor's local bus.
SZ [6:5]	The Size field is compared to the size signals of the processor's local bus. These signals indicate the data size for the bus transfer. 00 = Longword 01 = byte 10 = word 11 = reserved
TT [4:3]	The transfer type field is compared with the transfer type signals of the processor's local bus. These signals indicate the transfer type for the bus transfer. These signals are always encoded as if the ColdFire is in the ColdFire IACK mode. 00 = Normal Processor Access 01 = Reserved 10 = Emulator Mode Access 11 = Acknowledge/CPU Space Access These bits also define the TT encoding for BDM memory commands. In this case, the 01 encoding generates an alternate master access (for backward compatibility).

Table 19-25 Address Attribute Trigger Bit Descriptions (Continued)

BIT NAME	DESCRIPTION
TM [2:0]	<p>The transfer modifier field is compared with the transfer modifier signals of the processor's local bus. The signals provide supplemental information for each transfer type. The encoding for normal processor transfers (TT = 0) is:</p> <p>000 = Explicit Cache Line Push 001 = User Data Access 010 = User Code Access 011 = Reserved 100 = Reserved 101 = Supervisor Data Access 110 = Supervisor Code Access 111 = Reserved</p> <p>The encoding for emulator mode transfers (TT = 10) is:</p> <p>0xx = Reserved 100 = Reserved 101 = Emulator Mode Data Access 110 = Emulator Mode Code Access 111 = Reserved</p> <p>The encoding for acknowledge/CPU space transfers (TT = 11) is:</p> <p>000 = CPU Space Access 001 = Interrupt Acknowledge Level 1 010 = Interrupt Acknowledge Level 2 011 = Interrupt Acknowledge Level 3 100 = Interrupt Acknowledge Level 4 101 = Interrupt Acknowledge Level 5 110 = Interrupt Acknowledge Level 6 111 = Interrupt Acknowledge Level 7</p> <p>These bits also define the TM encoding for BDM memory commands (For backward compatibility).</p>

19.4.2.3 Program Counter Breakpoint Register (PBR, PBMR)

The PC breakpoint registers (PBR and PBMR) define a region in the code address space of the processor that can be used as part of the trigger. The PBR value is masked by the PBMR value, allowing only those bits in PBR that have a corresponding zero in PBMR to be compared with the processor's program counter register, as defined in the TDR. The PBR is accessible in supervisor mode as debug control register \$8 using the WDEBUB instruction and through the BDM port using the RDMREG and WDMREG commands. The PBMR is accessible in supervisor mode as debug control register \$9 using the WDEBUB instruction and through the BDM port using the WDMREG command.

Table 19-26 Program Counter Breakpoint Register (PBR)

BITS	31	30	29	28	27	26	25	24	23	22	21	20	19	18	17	16
FIELD	ADDRESS[31:0]															
RESET	-	-	-	-	-	-	-	-	-	-	-	-	-	-	-	-
R/W	WRITE ONLY															
BITS	15	14	13	12	11	10	9	8	7	6	5	4	3	2	1	0
FIELD	ADDRESS[31:0]															
RESET	-	-	-	-	-	-	-	-	-	-	-	-	-	-	-	-
R/W	WRITE ONLY															

ADDRESS[31:0]—PC Breakpoint Address

This field contains the 32-bit address to be compared with the PC as a breakpoint trigger.

Table 19-27 Program Counter Breakpoint Mask Register (PBMR)

BITS	31	30	29	28	27	26	25	24	23	22	21	20	19	18	17	16
FIELD	MASK [31:0]															
RESET	-	-	-	-	-	-	-	-	-	-	-	-	-	-	-	-
R/W	WRITE ONLY															
BITS	15	14	13	12	11	10	9	8	7	6	5	4	3	2	1	0
FIELD	MASK [31:0]															
RESET	-	-	-	-	-	-	-	-	-	-	-	-	-	-	-	-
R/W	WRITE ONLY															
ADDR																

MASK[31:0]—PC Breakpoint Mask

This field contains the 32-bit mask for the PC breakpoint trigger. A zero in a bit position causes the corresponding bit in the PBR to be compared to the appropriate bit of the PC. A one causes that bit to be ignored.

19.4.2.4 Data Breakpoint Registers (DBR, DBMR)

The data breakpoint registers (DBR and DBMR) define a specific data pattern that can be used as part of the trigger into debug mode. The DBR value is masked by the DBMR value, allowing only those bits in DBR that have a corresponding zero in DBMR to be compared with the data value from the processor's local bus, as defined in the TDR. The DBR is accessible in supervisor mode as debug control register \$E using the WDEBUG instruction and through the BDM port using the RDMREG and WDMREG commands. The DBMR is accessible in supervisor mode as debug control register \$F using the WDEBUG instruction and through the BDM port using the WDMREG command. The DBR is overwritten by the BDM hardware when accessing memory as described in [Section 19.4.1.2 Debug Module Hardware](#).

Table 19-28 Data Breakpoint Register (DBR)

BITS	31	30	29	28	27	26	25	24	23	22	21	20	19	18	17	16
FIELD	ADDRESS [31:0]															
RESET	-	-	-	-	-	-	-	-	-	-	-	-	-	-	-	-
R/W	WRITE ONLY															
ADDR																
BITS	15	14	13	12	11	10	9	8	7	6	5	4	3	2	1	0
FIELD	ADDRESS [31:0]															
RESET	-	-	-	-	-	-	-	-	-	-	-	-	-	-	-	-
R/W	WRITE ONLY															

DATA[31:0]—Data Breakpoint Value

This field contains the 32-bit value to be compared with the data value from the processor’s local bus as a breakpoint trigger.

Table 19-29 Data Breakpoint Mask Register (DBMR)

BITS	31	30	29	28	27	26	25	24	23	22	21	20	19	18	17	16
FIELD	MASK [31:0]															
RESET	-	-	-	-	-	-	-	-	-	-	-	-	-	-	-	-
R/W	WRITE ONLY															
BITS	15	14	13	12	11	10	9	8	7	6	5	4	3	2	1	0
FIELD	MASK [31:0]															
RESET	-	-	-	-	-	-	-	-	-	-	-	-	-	-	-	-
R/W	WRITE ONLY															

MASK[31:0]—Data Breakpoint Mask

This field contains the 32-bit mask for the data breakpoint trigger. A zero in a bit position causes the corresponding bit in the DBR to be compared to the appropriate bit of the internal data bus. A one causes that bit to be ignored

The data breakpoint register supports both aligned and misaligned references. The relationship between the processor address, the access size, and the corresponding location within the 32-bit data bus is shown in [Table 19-30](#).

Table 19-30 Access and Operand Data Location

ADDRESS[1:0]	ACCESS SIZE	OPERAND LOCATION
00	Byte	Data[31:24]
01	Byte	Data[23:16]
10	Byte	Data[15:8]
11	Byte	Data[7:0]
0x	Word	Data[31:16]
1x	Word	Data[15:0]
xx	Long	Data[31:0]

19.4.2.5 Trigger Definition Register (TDR)

The TDR configures the operation of the hardware breakpoint logic within the debug module and controls the actions taken under the defined conditions. The breakpoint logic may be configured as a one- or two-level trigger, where bits [31:16] of the TDR define the 2nd level trigger and bits [15:0] define the first level trigger. The TDR is accessible in supervisor mode as debug control register \$7 using the WDEBUG instruction and through the BDM port using the WDMREG command.

Table 19-31 Trigger Definition Register (TDR)

BITS	31	30	29	28	27	26	25	24	23	22	21	20	19	18	17	16
FIELD	TRC		TRC	EDLW	EDWL	EDWU	EDLL	EDLM	EDUM	EDUU	DI	EAI	EAR	EAL	EPC	PCI
RESET	0	0	0	0	0	0	0	0	0	0	0	0	0	0	0	0
R/W	WRITE ONLY															
BITS	15	14	13	12	11	10	9	8	7	6	5	4	3	2	1	0
FIELD	LXT		EBL	EDLW	EDWL	EDWU	EDLL	EDLM	EDUM	EDUU	DI	EAI	EAR	EAL	EPC	PCI
RESET	0	0	0	0	0	0	0	0	0	0	0	0	0	0	0	0
R/W	WRITE ONLY															

Table 19-32 Trigger Definition Bit Descriptions

BIT NAME	DESCRIPTION
TRC	The trigger response control determines how the processor is to respond to a completed trigger condition. The trigger response is always displayed on the DDATA pins. 00 = display on DDATA only 01 = processor halt 10 = debug interrupt 11 = reserved
TDR[15]	0 = Level-2 trigger = PC_condition & Address_range & Data_condition 1 = Level-2 trigger = PC_condition (Address_range & Data_condition)
TDR[14]	0 = Level-1 trigger = PC_condition & Address_range & Data_condition 1 = Level-1 trigger = PC_condition (Address_range & Data_condition)
EBL	If set, the Enable Breakpoint Level bit serves as the global enable for the breakpoint trigger. If cleared, all breakpoints are disabled.
EDLW	If set, the Enable Data Breakpoint for the Data Longword bit enables the data breakpoint based on the entire processor's local data bus. The assertion of any of the ED bits enables the data breakpoint. If all bits are cleared, the data breakpoint is disabled.
EDWL	If set, the Enable Data Breakpoint for the Lower Data Word bit enables the data breakpoint based on the low-order word of the processor's local data bus.
EDWU	If set, the Enable Data Breakpoint for the Upper Data Word bit enables the data breakpoint trigger based on the high-order word of the processor's local data bus.
EDLL	If set, the Enable Data Breakpoint for the Lower Data Byte bit enables the data breakpoint trigger based on the low-order byte of the low-order word of the processor's local data bus.
EDLM	If set, the Enable Data Breakpoint for the Lower Lower Middle Data Byte bit enables the data breakpoint trigger based on the high-order byte of the low-order word of the processor's local data bus.
EDUM	If set, the Enable Data Breakpoint for the Upper Middle Data Byte bit enables the data breakpoint trigger on the low-order byte of the high-order word of the processor's local data bus.
EDUU	If set, the Enable Data Breakpoint for the Upper Upper Data Byte bit enables the data breakpoint trigger on the high-order byte of the high-order word of the processor's local data bus.
DI	The Data Breakpoint Invert bit provides a mechanism to invert the logical sense of all the data breakpoint comparators. This can develop a trigger based on the occurrence of a data value not equal to the one programmed into the DBR.

Table 19-32 Trigger Definition Bit Descriptions (Continued)

BIT NAME	DESCRIPTION
EAI	If set, the Enable Address Breakpoint Inverted bit enables the address breakpoint based outside the range defined by ABLR and ABHR. The assertion of any of the EA bits enables the address breakpoint. If all three bits are cleared, this breakpoint is disabled.
EAR	If set, the Enable Address Breakpoint Range bit enables the address breakpoint based on the inclusive range defined by ABLR and ABHR.
EAL	If set, the Enable Address Breakpoint Low bit enables the address breakpoint based on the address contained in the ABLR.
EPC	If set, the Enable PC Breakpoint bit enables the PC breakpoint.
PCI	If set, the PC Breakpoint Invert bit allows execution outside a given region as defined by PBR and PBMR to enable a trigger. If cleared, the PC breakpoint is defined within the region defined by PBR and PBMR.

19.4.2.6 Configuration/Status Register (CSR)

The CSR defines the debug configuration for the processor and memory subsystem. In addition to defining the microprocessor configuration, this register also contains status information from the breakpoint logic. The CSR is cleared during system reset. The CSR can be read and written by the external development system and written by the supervisor programming model. The CSR is accessible in supervisor mode as debug control register \$0 using the WDEBUG instruction and through the BDM port using the RDMREG and WDMREG commands.

Table 19-33 Configuration/Status Register (CSR)

BITS	31	30	29	28	27	26	25	24	23	22	21	20	19	18	17	16
FIELD	STATUS				FOF	TRG	HALT	BKPT	HRL				-	BKD	PCD	IPW
RESET	0	0	0	0	0	0	0	0								0
R/W	READ ONLY				R	R	R	R	READ ONLY				-	-	R/W	R/W
ADDR																
BITS	15	14	13	12	11	10	9	8	7	6	5	4	3	2	1	0
FIELD	MAP	TRC	EMU	DDC		UHE	BTB		-	NPL	IPI	SSM	-			
RESET	0	0	0	0	0	0	0	0	0	0	0	0	-			
R/W	R/W	R/W	R/W	R/W		R/W	R/W		R	R/W	R/W	R/W				
ADDR																
Note:	The CSR is a write only register from the programming model. It can be read from and written to through the BDM port.															

Table 19-34 Configuration/Status Bit Descriptions

BIT NAME	DESCRIPTION
STATUS[31:28]	The Breakpoint Status 4-bit field provides read-only status information concerning the hardware breakpoints. This field is defined as follows: 000x = no breakpoints enabled 001x = waiting for level 1 breakpoint 010x = level 1 breakpoint triggered 101x = waiting for level 2 breakpoint 110x = level 2 breakpoint triggered The breakpoint status is also output on the DDATA port when it is not busy displaying other processor data. A write to the TDR resets this field.
FOF[27]	If the read-only Fault-on-Fault status bit is set, a catastrophic halt has occurred and forced entry into BDM. This bit is cleared on a read from the CSR.
TRG[26]	If the read-only Hardware Breakpoint Trigger status bit is set, a hardware breakpoint has halted the processor core and forced entry into BDM. This bit is cleared by reading CSR.
HALT[25]	If the read-only Processor Halt status bit is set, the processor has executed the HALT instruction and forced entry into BDM. This bit is cleared by reading the CSR.
$\overline{\text{BKPT}}$ [24]	If the read-only Breakpoint Assert status bit is set, the $\overline{\text{BKPT}}$ signal was asserted, forcing the processor into BDM. This bit is cleared on a read from the CSR.
HRL[23:20]	This hardware revision level indicates the level of functionality implemented in the debug module. This information could be used by an emulator to identify the level of functionality supported. A zero value would indicate the initial debug functionality. For example, a value of 1 would represent Revision A while a value of 0 would represent the earlier release of Revision A.

Table 19-34 Configuration/Status Bit Descriptions (Continued)

BIT NAME	DESCRIPTION
BKD[18]	<p>The Disable the Normal $\overline{\text{BKPT}}$ Input Signal Functionality bit is used to disable the normal $\overline{\text{BKPT}}$ input signal functionality, and allow the assertion of this pin to generate a debug interrupt. If set, the assertion of the $\overline{\text{BKPT}}$ pin is treated as an edge-sensitive event. Specifically, a high-to-low edge on the $\overline{\text{BKPT}}$ pin generates a signal to the processor indicating a debug interrupt. The processor makes this interrupt request pending until the next sample point occurs. At that time, the debug interrupt exception is initiated. In the ColdFire architecture, the interrupt sample point occurs once per instruction. There is no support for any type of “nesting” of debug interrupts.</p>
PCD[17]	<p>If set, the PSTCLK Disable bit disables the generation of the PSTCLK output signal, and forces this signal to remain quiescent.</p>
IPW[16]	<p>If set, the Inhibit Processor Writes to Debug Registers bit inhibits any processor-initiated writes to the debug module’s programming model registers. This bit can only be modified by commands from the external development system.</p>
MAP[15]	<p>If set, the Force Processor References in Emulator Mode bit forces the processor to map all references while in emulator mode to a special address space, TT = \$2, TM = \$5 or \$6. If cleared, all emulator-mode references are mapped into supervisor code and data spaces.</p>
TRC[14]	<p>If set, the Force Emulation Mode on Trace Exception bit forces the processor to enter emulator mode when a trace exception occurs.</p>
EMU[13]	<p>If set, the Force Emulation Mode bit forces the processor to begin execution in emulator mode. Refer to Section 19.4.1.1 Emulator Mode.</p>
DDC[12:11]	<p>The 2-bit Debug Data Control field provides configuration control for capturing operand data for display on the DDATA port. The encoding is: 00 = no operand data is displayed 01 = capture all M-Bus write data 10 = capture all M-Bus read data 11 = capture all M-Bus read and write data</p> <p>In all cases, the DDATA port displays the number of bytes defined by the operand reference size. For example, byte displays 8 bits, word displays 16 bits, and long displays 32 bits (one nibble at a time across multiple clock cycles.) Refer to Section 19.2.1.7 Begin Data Transfer (PST = \$8–\$B).</p>
UHE[10]	<p>The User Halt Enable bit selects the CPU privilege level required to execute the HALT instruction. 0 = HALT is a privileged, supervisor-only instruction 1 = HALT is a non-privileged, supervisor/user instruction</p>
BTB[9:8]	<p>The 2-bit Branch Target Bytes field defines the number of bytes of branch target address to be displayed on the DDATA outputs. The encoding is: 00 = 0 bytes 01 = lower two bytes of the target address 10 = lower three bytes of the target address 11 = entire four-byte target address</p> <p>Refer to Section 19.2.1.5 Begin Execution of Taken Branch (PST = \$5).</p>

Table 19-34 Configuration/Status Bit Descriptions (Continued)

BIT NAME	DESCRIPTION
NPL[6]	<p>If set, the Non-Pipelined Mode bit forces the processor core to operate in a nonpipeline mode of operation. In this mode, the processor effectively executes a single instruction at a time with no overlap.</p> <p>When operating in non-pipelined mode, performance is severely degraded. For the V3 design, operation in this mode essentially adds 6 cycles to the execution time of each instruction. Given that the measured Effective Cycles per Instruction for V3 is ~2 cycles/instruction, meaning performance in non-pipeline mode would be ~8 cycles/instruction, or approximately 25% compared to the pipelined performance.</p> <p>Regardless of the state of CSR[6], if a PC breakpoint is triggered, it is always reported before the instruction with the breakpoint is executed. The occurrence of an address and/or data breakpoint trigger is imprecise in normal pipeline operation. When operating in non-pipeline mode, these triggers are always reported before the next instruction begins execution. In this mode, the trigger reporting can be considered to be precise.</p> <p>As previously detailed, the occurrence of an address and/or data breakpoint should always happen before the next instruction begins execution. Therefore the occurrence of the address/data breakpoints should be guaranteed.</p>
IPI[5]	<p>If set, the Ignore Pending Interrupts bit forces the processor core to ignore any pending interrupt requests signalled while executing in single-instruction-step mode.</p>
SSM[4]	<p>If set, the Single-Step Mode bit forces the processor core to operate in a single-instruction-step mode. While in this mode, the processor executes a single instruction and then halts. While halted, any of the BDM commands may be executed. On receipt of the GO command, the processor executes the next instruction and then halts again. This process continues until the single-instruction-step mode is disabled.</p>

19.4.2.7 BDM Address Attribute (BAAR)

The BAAR register defines the address space for memory-referencing BDM commands. Bits [7:5] are loaded directly from the BDM command, while the low-order 5 bits can be programmed from the external development system. To maintain compatibility with the Rev. A implementation, this register is loaded any time the AATR is written. The BAR is initialized to a value of \$5, setting “supervisor data” as the default address space.

Table 19-35 BDM Address Attribute Register (BAAR)

BITS	7	6	5	4	3	2	1	0
FIELD	R	SZ		TT		TM		
RESET	0	0	0	0	0	1	0	1
R/W	WRITE ONLY							

Table 19-36 BDM Address Attribute (BAAR) Bit Descriptions

BIT NAME	DESCRIPTION
R[7]	0 = Write 1 = Read
SZ[6:5]	Size 00 = Longword 01 = Byte 10 = Word 11 = Reserved
TT[4:3]	Transfer Type See the TT definition in the AATR description, Section 19.4.2.2 Address Attribute Trigger Register .
TM[2:0]	Transfer Modifier See the TM definition in the AATR description, Section 19.4.2.2 Address Attribute Trigger Register .

19.4.3 CONCURRENT BDM AND PROCESSOR OPERATION

The debug module supports concurrent operation of both the processor and most BDM commands. BDM commands may be executed while the processor is running, except for the operations that access processor/memory registers:

- Read/Write Address and Data Registers
- Read/Write Control Registers

For BDM commands that access memory, the debug module requests the processor's local bus. The processor responds by stalling the instruction fetch pipeline and then waiting until all current bus activity is complete. At that time, the processor relinquishes the local bus to allow the debug module to perform the required operation. After the conclusion of the debug module bus cycle, the processor reclaims ownership of the bus.

The development system must use caution in configuring the breakpoint registers if the processor is executing. The debug module does not contain any hardware interlocks, so Motorola recommends that the TDR be disabled while the breakpoint registers are being loaded. At the conclusion of this process, the TDR can be written to define the exact trigger. This approach guarantees that no spurious breakpoint triggers occur.

Because there are no hardware interlocks in the debug unit, no BDM operations are allowed while the CPU is writing the debug's registers ($\overline{\text{BKPT}}$ and DSCLK must be inactive).

19.4.4 MOTOROLA-RECOMMENDED BDM PINOUT

The ColdFire BDM connector is a 26-pin Berg Connector arranged 2x13, shown in [Figure 19-26](#).

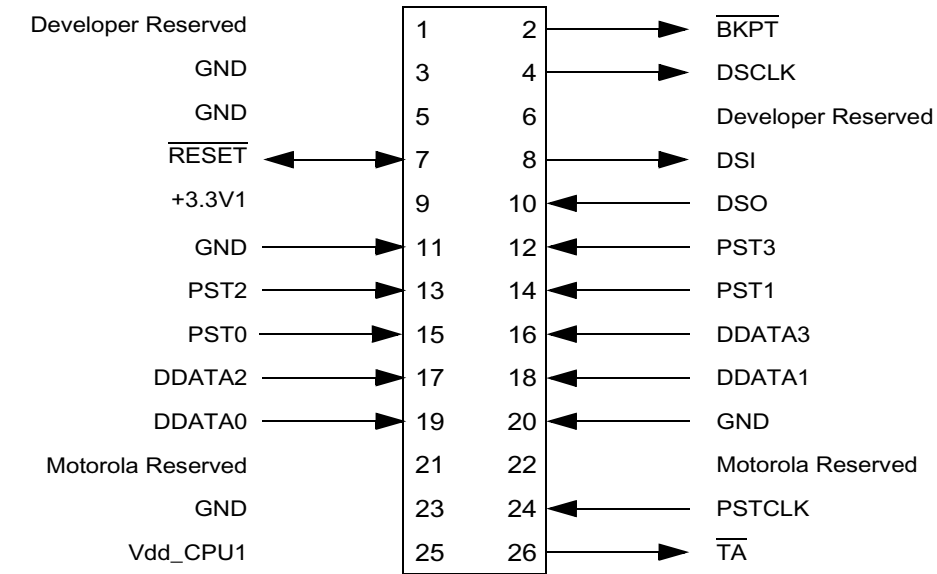

- NOTES: 1. Supplied by target
 2. Pins reserved for BDM developer use. Contact developer.

Figure 19-26 Recommended BDM Connector

NOTES

Section 20

IEEE 1149.1 Test Access Port (JTAG)

The MCF5249 JTAG test architecture implementation currently supports circuit board test strategies that are based on the IEEE standard. This architecture provides access to all of the data and chip control pins from the board edge connector through the standard four-pin test access port (TAP) and the active-low JTAG reset pin, $\overline{\text{TRST}}$. The test logic uses static design and is wholly independent of the system logic, except where the JTAG is subordinate to other complimentary test modes (see the DEBUG section, for more information). When in subordinate mode, the JTAG test logic is placed in reset and the TAP pins can be used for other purposes in accordance with the rules and restrictions set forth using a JTAG compliance-enable pin.

The MCF5249 JTAG implementation can do the following:

- Perform boundary-scan operations to test circuit board electrical continuity
- Bypass the MCF5249 by reducing the shift register path to a single cell
- Sample the MCF5249 system pins during operation and transparently shift out the result
- Set the MCF5249 output drive pins to fixed logic values while reducing the shift register path to a single cell
- Protect the MCF5249 system output and input pins from backdriving and random toggling (such as during in-circuit testing) by placing all system signal pins to high- impedance state

Note: The IEEE Standard 1149.1 test logic cannot be considered completely benign to those planning not to use JTAG capability. Users must observe certain precautions to ensure that this logic does not interfere with system or debug operation. Refer to Section [20.6 Disabling IEEE 1149.1A Standard Operation](#) .

20.1 JTAG OVERVIEW

Figure 20-1 is a block diagram of the MCF5249 implementation of the 1149.1 IEEE Standard. The test logic includes several test data registers, an instruction register, instruction register control decode, and a 16-state dedicated TAP controller.

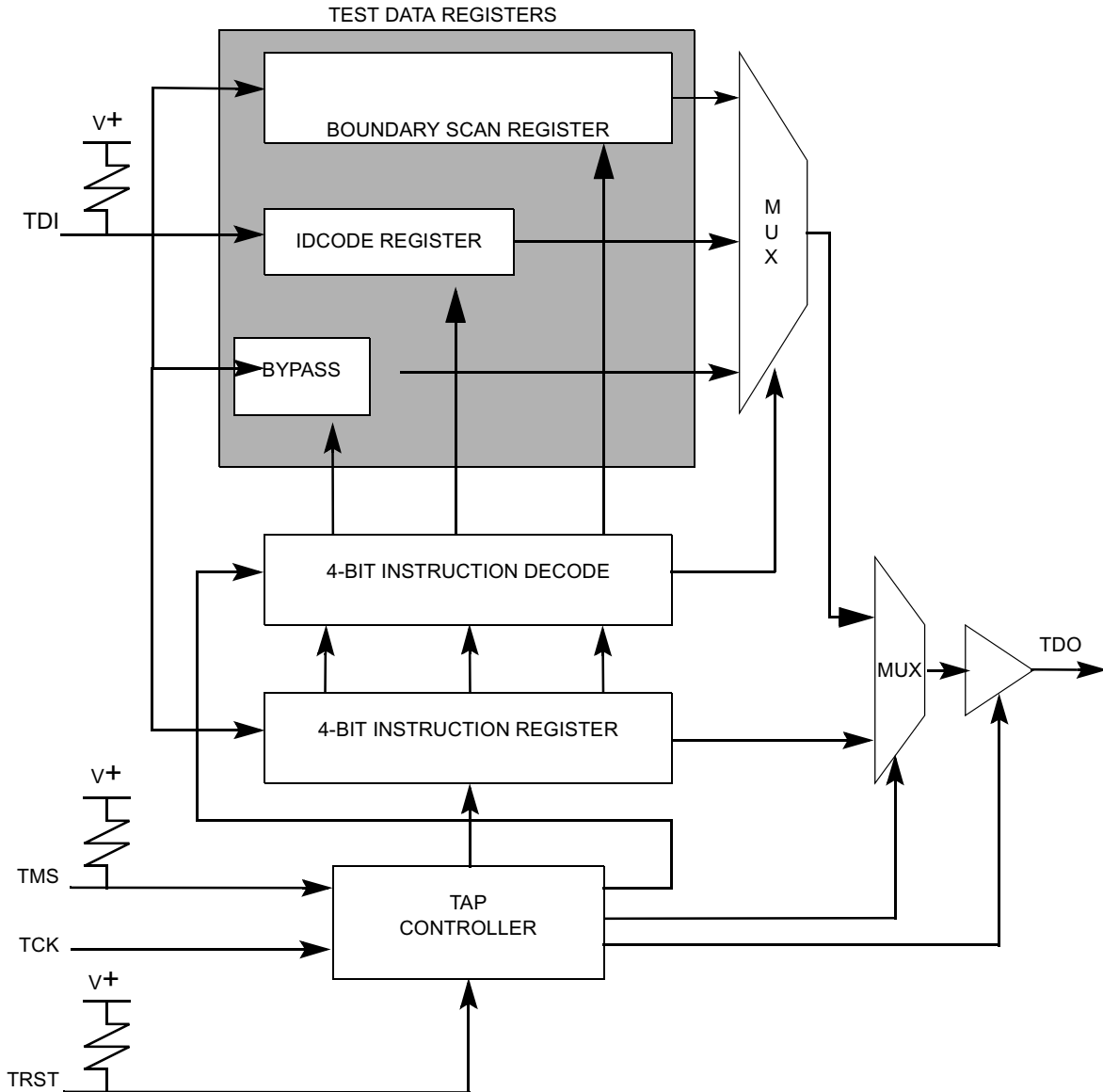

Figure 20-1 JTAG Test Logic Block Diagram

20.2 JTAG SIGNAL DESCRIPTIONS

The JTAG operation on the MCF5249 is enabled when test[3:0]= 0000, in which case the external pin descriptions in [Table 20-1](#) apply. Otherwise, the JTAG Test Access Port signals (TCK/TMS/TDI/TDO/TRST) are interpreted as the Debug port pins.

Table 20-1 JTAG Pin Descriptions

PIN	DESCRIPTION
TCK	A test clock input that synchronizes test logic operations
TMS	A test mode select input with a default internal pullup resistor that is sampled on the rising edge of TCK to sequence the TAP controller
TDI	A serial test data input with a default internal pullup resistor that is sampled on the rising edge of TCK
TDO	A three-state test data output that is actively driven only in the Shift-IR and Shift-DR controller states and only updates on the falling edge of TCK
TRST	An active-low asynchronous reset with a default internal pullup resistor that forces the TAP controller into the test-logic-reset state.

20.2.1 TEST CLOCK - (TCK)

TCK is the dedicated JTAG test logic clock that is independent of the MCF5249 processor clock. Various JTAG operations occur on the rising or falling edge of TCK. The internal JTAG controller logic is designed such that holding TCK high or low for an indefinite period of time will not cause the JTAG test logic to lose state information. If TCK is not used, it should be tied to vdd. There is an internal pullup connected to this pin.

20.2.2 TEST RESET/DEVELOPMENT SERIAL CLOCK - ($\overline{\text{TRST}}$ /DSCLK)

The TEST[3:0] signals determine the function of this dual-purpose pin. If TEST[3:0]=0001, the DSCLK function is selected. If TEST[3:0]= 0000, the TRST function is selected, the pin got an internal pullup and the JTAG reset is executed. For all other modes the signal is forced internally to its active value. test[3:0] should not be changed while $\overline{\text{RSTI}}$ is asserted.

When used as $\overline{\text{TRST}}$, this pin asynchronously resets the internal JTAG controller to the test logic reset state, causing the JTAG instruction register to choose the "idcode" command. When this occurs, all the JTAG logic is benign and will not interfere with the normal functionality of the MCF5249 processor. Although this signal is asynchronous, Motorola recommends that $\overline{\text{TRST}}$ make only a 0 to 1 (asserted to negated) transition while TMS is held at a logic 1 value. $\overline{\text{TRST}}$ has an internal pullup so that if it is not driven low its value will default to a logic level of 1. However, if $\overline{\text{TRST}}$ will not be used, it can either be tied to ground or, if TCK is clocked, it can be tied to VDD. The former connection will place the JTAG controller in the test logic reset state immediately, while the later connection will cause the JTAG controller (if TMS is a logic 1) to eventually end up in the test logic reset state after 5 clocks of TCK.

This pin is also used as the development serial clock (DSCLK) for the serial interface to the Debug Module. The maximum frequency for the DSCLK signal is 1/2 the BCLKO frequency.

20.2.3 TEST MODE SELECT/ BREAKPOINT ($\overline{\text{TMS}}$ /BKPT)

The test[3:0] signals determine this pin's dual function. If TEST[3:0] =0001, the $\overline{\text{BKPT}}$ function is selected. If TEST[3:0] = 0000, then the TMS function is selected. TEST[3:0] should not change while $\overline{\text{RSTI}}$ is asserted. When used as TMS, this input signal provides the JTAG controller with information to determine which test operation mode should be performed. The value of TMS and current state of the internal 16-state JTAG controller state machine at the rising edge of TCK determine whether the JTAG controller holds its current state or advances to the next state. This directly controls whether JTAG data or instruction

operations occur. TMS has an internal pullup so that if it is not driven low, its value will default to a logic level of 1. However, if TMS will not be used, it should be tied to VDD. This pin also signals a hardware breakpoint to the processor when in the debug mode.

20.2.4 TEST DATA INPUT/DEVELOPMENT SERIAL INPUT - (TDI/DSI)

This is a dual-function pin. If TEST[3:0] = 0001, then DSI is selected. If TEST[3:0] = 0000, then TDI is selected. When used as TDI, this input signal provides the serial data port for loading the various JTAG shift registers composed of the boundary scan register, the bypass register, and the instruction register. Shifting in of data depends on the state of the JTAG controller state machine and the instruction currently in the instruction register. This data shift occurs on the rising edge of TCK. TDI also has an internal pullup so that if it is not driven low its value will default to a logic level of 1. However, if TDI will not be used, it should be tied to VDD.

This pin also provides the single-bit communication for the debug module commands.

20.2.5 TEST DATA OUTPUT/DEVELOPMENT SERIAL OUTPUT - (TDO/DSO)

This is a dual-function pin. When TEST[3:0] = 0001, then DSO is selected. When TEST[3:0] = 0000, TDO is selected. When used as TDO, this output signal provides the serial data port for outputting data from the JTAG logic. Shifting out of data depends on the state of the JTAG controller state machine and the instruction currently in the instruction register. This data shift occurs on the falling edge of TCK. When TDO is not outputting test data, it is three-stated. TDO can also be placed in three-state mode to allow bussed or parallel connections to other devices having JTAG.

20.3 TAP CONTROLLER

The state of TMS at the rising edge of TCK determines the current state of the TAP controller. There are basically two paths that the TAP controller can follow: The first, for executing JTAG instructions; the second, for manipulating JTAG data based on the JTAG instructions. The various states of the TAP controller are shown in [Figure 20-2](#). For more detail on each state, refer to the IEEE 1149.1A Standard JTAG document.

Note: From any state that the TAP controller is in, Test-Logic-Reset can be entered if TMS is held high for at least five rising edges of TCK.

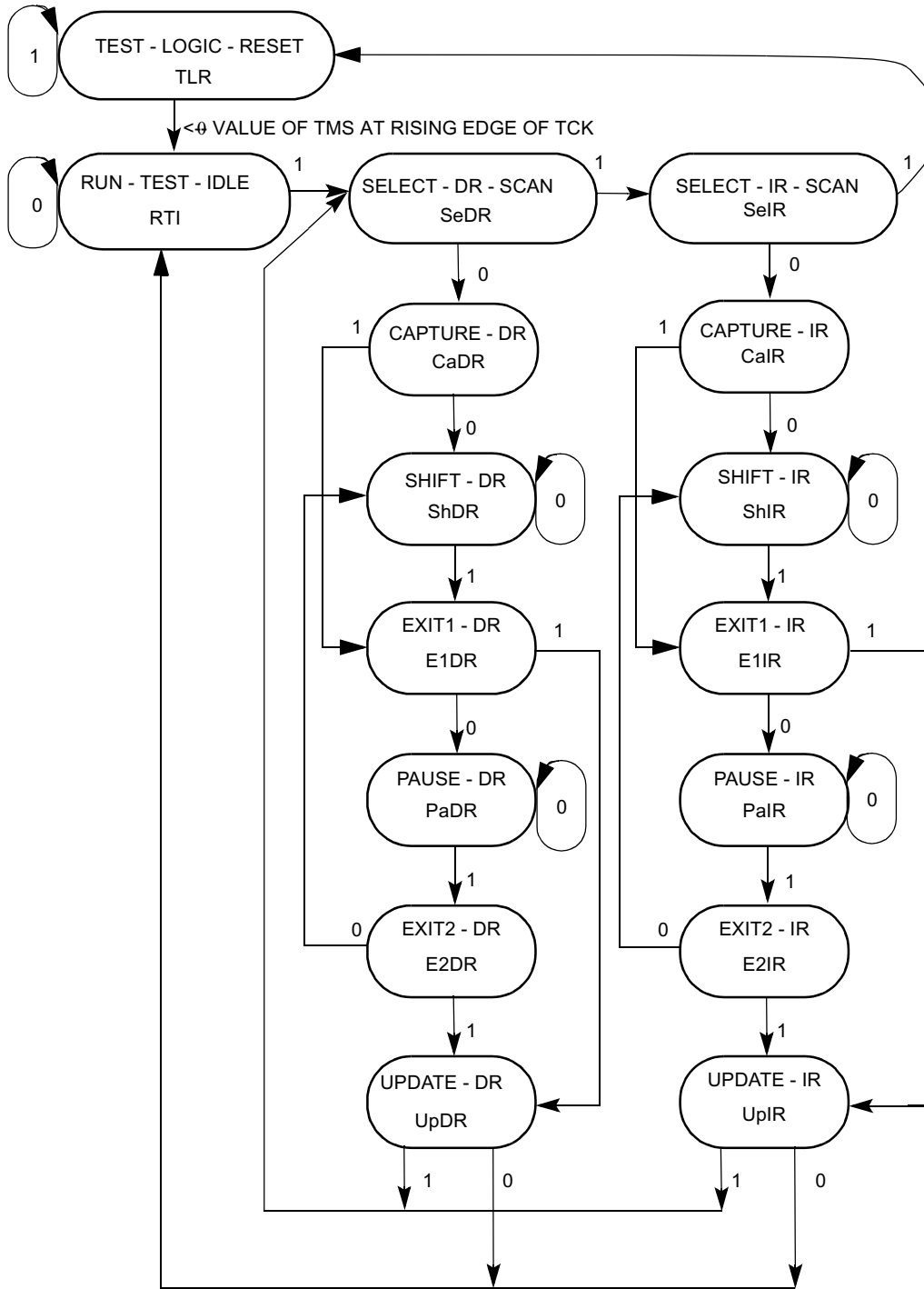

Figure 20-2 JTAG TAP Controller State Machine

20.4 JTAG REGISTERS

20.4.1 JTAG INSTRUCTION SHIFT REGISTER

The MCF5249 IEEE 1149.1A Standard implementation uses a 4-bit instruction-shift register without parity. This register transfers its value to a parallel hold register and applies one of eight possible instructions on the falling edge of TCK when the TAP state machine is in the update-IR state. To load the instructions into the shift portion of the register, place the serial data on the TDI pin prior to each rising edge of TCK. The MSB of the instruction shift register is the bit closest to the TDI pin and the LSB is the bit closest to the TDO pin.

Table 20-2 lists the public, usable instructions that are supported along with their encoding.

Table 20-2 JTAG Instructions

INSTRUCTION	ABBR	CLASS	IR[3:0]	INSTRUCTION SUMMARY
EXTEST	EXT	Required	0000	Select BS register while applying fixed values to output pins and asserting functional reset
IDCODE	IDC	Optional	0001	Selects IDCODE register for shift
SAMPLE/ PRELOAD	SMP	Required	0010	Selects BS register for shift, sample, and preload without disturbing functional operation
CLAMP	CMP	Optional	0011	Selects bypass while applying fixed values to output pins and asserting functional reset
HIGHZ	HIZ	Optional	0100	Selects the bypass register while three-stating all output pins and asserting functional reset
RINGOSC	RING	Optional	0111	User defined function for device test
ORGATE	OR	Optional	1000	User defined function for device test
BYPASS	BYP	Required	1111	Selects the bypass register for data operations

The IEEE 1149.1A Standard requires the EXTEST, SAMPLE/PRELOAD, and BYPASS instructions. IDCODE, CLAMP, HIGHZ are optional standard instructions that the MCF5249 implementation supports and are described in the IEEE Standard 1149.1. The RINGOSC and ORGATE are user defined instructions only used for device test during manufacturing.

20.4.1.1 EXTEST Instruction

The external test instruction (EXTEST) selects the boundary-scan register. The EXTEST instruction forces all output pins and bidirectional pins configured as outputs to the preloaded fixed values (with the SAMPLE/PRELOAD instruction) and held in the boundary-scan update registers. The EXTEST instruction can also configure the direction of bidirectional pins and establish high-impedance states on some pins. The EXTEST instruction becomes active on the falling edge of TCK in the update-IR state when the data held in the instruction-shift register is equivalent to hex 0.

20.4.1.2 IDCODE

The IDCODE instruction selects the 32-bit IDcode register for connection as a shift path between the TDI pin and the TDO pin. This instruction lets users interrogate the MCF5249 to determine its version number

and other part identification data. The IDcode register has been implemented in accordance with IEEE 1149.1A so that the least significant bit of the shift register stage is set to logic 1 on the rising edge of TCK following entry into the capture-DR state. Therefore, the first bit to be shifted out after selecting the IDcode register is always a logic 1. The remaining 31-bits are also set to fixed values (see section [20.4.2 IDcode Register](#)) on the rising edge of TCK following entry into the capture-DR state.

The IDCODE instruction is the default value placed in the instruction register when a JTAG reset is accomplished by either asserting $\overline{\text{TRST}}$ or holding TMS high while clocking TCK through at least five rising edges and the falling edge after the fifth rising edge. A JTAG reset will cause the TAP state machine to enter the test-logic-reset state (normal operation of the TAP state machine into the test-logic-reset state will also result in placing the default value of octal 1 into the instruction register). The shift register portion of the instruction register is loaded with the default value of hex 1 when in the Capture-IR state and a rising edge of TCK occurs.

20.4.1.3 SAMPLE/PRELOAD Instruction

The SAMPLE/PRELOAD instruction provides two separate functions. First, it obtains a sample of the system data and control signals present at the MCF5249 input pins and just prior to the boundary scan cell at the output pins. This sampling occurs on the rising edge of TCK in the capture-DR state when an instruction encoding of hex 2 is resident in the instruction register. Users can observe this sampled data by shifting it through the boundary-scan register to the output TDO by using the shift-DR state. Both the data capture and the shift operation are transparent to system operation. Users are responsible for providing some form of external synchronization to achieve meaningful results because there is no internal synchronization between TCK and the system clock, CLK.

The second function of the SAMPLE/PRELOAD instruction is to initialize the boundary scan register update cells before selecting EXTEST or CLAMP. This is achieved by ignoring the data being shifted out of the TDO pin while shifting in initialization data. The update-DR state in conjunction with the falling edge of TCK can then transfer this data to the update cells. This data will be applied to the external output pins when one of the instructions listed above is applied.

20.4.1.4 CLAMP Instruction

The CLAMP instruction selects the bypass register and asserts functional reset while simultaneously forcing all output pins and bidirectional pins configured as outputs to the fixed values that are preloaded and held in the boundary-scan update registers. This instruction enhances test efficiency by reducing the overall shift path to a single bit (the bypass register) while conducting an EXTEST type of instruction through the boundary-scan register. The CLAMP instruction becomes active on the falling edge of TCK in the update-IR state when the data held in the instruction-shift register is equivalent to hex 3.

20.4.1.5 HIGHZ Instruction

The HIGHZ instruction anticipates the need to backdrive the output pins and protect the input pins from random toggling during circuit board testing. The HIGHZ instruction selects the bypass register, forcing all output and bidirectional pins to the high-impedance state.

The HIGHZ instruction goes active on the falling edge of TCK in the update-IR state when the data held in the instruction shift register is equivalent to hex 4.

20.4.1.6 BYPASS Instruction

The BYPASS instruction selects the single-bit bypass register, creating a single-bit shift register path from the TDI pin to the bypass register to the TDO pin. This instruction enhances test efficiency by reducing the overall shift path when a device other than the MCF5249 processor becomes the device under test on a board design with multiple chips on the overall 1149.1 defined boundary-scan chain. The bypass register

JTAG Registers

has been implemented in accordance with 1149.1 so that the shift register stage is set to logic zero on the rising edge of TCK following entry into the capture-DR state. Therefore, the first bit to be shifted out after selecting the bypass register is always a logic zero (to differentiate a part that supports an IDCODE register from a part that supports only the bypass register). The BYPASS instruction goes active on the falling edge of TCK in the update-IR state when the data held in the instruction shift register is equivalent to hex F.

20.4.2 IDCODE REGISTER

An IEEE 1149.1A compliant JTAG identification register has been included on the MCF5249. The MCF5249 JTAG instruction encoded as hex 1 provides for reading the JTAG IDcode register.

Table 20-3 ID Code Register Command

BITS	31	30	29	28	27	26	25	24	23	22	21	20	19	18	17	16	
FIELD	VERSION NUMBER				DESIGN CENTER						DEVICE NUMBER						
RESET	0	0	1	0	0	1	0	1	0	1	0	0	0	0	0	0	
R/W																	
ADDR																	
BITS	15	14	13	12	11	10	9	8	7	6	5	4	3	2	1	0	
FIELD	DEVICE NUMBER				JEDECID											JTAGID	
RESET	0	1	1	0	0	0	0	0	0	0	0	0	1	1	1	0	1
R/W																	
ADDR																	

Table 20-4 ID Code Bit Descriptions

BIT NAME	DESCRIPTION
Bits 31-28	The Version Number bits indicate the revision number of the MCF5249.
Bits 27-22	The Design Center bits indicate the Munich design center.
Bits 21-12	The Device Number bits indicate an MCF5249.
Bits 11-1	The JEDEC ID bits indicate the reduced JEDEC ID for Motorola (JEDEC refers to the Joint Electron Device Engineering Council. Refer to JEDEC publication 106-A and section 11 of the IEEE 1149.1A Standard for further information on this field).
Bit 0	Differentiates this register as the JTAG ID code register (as opposed to the bypass register) according to the IEEE 1149.1A Standard.

20.4.3 JTAG BOUNDARY SCAN REGISTER

The MCF5249 model includes an IEEE 1149.1A-compliant boundary-scan register. The boundary-scan register is connected between TDI and TDO when the EXTEST or SAMPLE/PRELOAD instructions are selected. This register captures signal pin data on the input pins, forces fixed values on the output signal pins, and selects the direction and drive characteristics (a logic value or high impedance) of the bidirectional and three-state signal pins. A detailed description of the boundary scan register bits for the MCF5249 is part of the BSDL file listed in [Section 20.7](#).

20.4.4 JTAG BYPASS REGISTER

The MCF5249 includes an IEEE 1149.1A-compliant bypass register, which creates a single bit shift register path from TDI to the bypass register to TDO when the BYPASS instruction is selected.

20.5 RESTRICTIONS

The test logic is implemented using static logic design, and TCK can be stopped in either a high or low state without loss of data. The system logic, however, operates on a different system clock which is not synchronized to TCK internally. Any mixed operation requiring the use of 1149.1 test logic in conjunction with system functional logic that uses both clocks, must have coordination and synchronization of these clocks done externally to the MCF5249.

20.6 DISABLING IEEE 1149.1A STANDARD OPERATION

There are two ways to use the MCF5249 without the IEEE 1149.1A test logic being active:

1. Nonuse of the JTAG test logic by either nontermination (disconnection) or intentional fixing of TAP logic values.
2. Intentional disabling of the JTAG test logic by setting test[3:0]= 0001 (entering Debug mode)

There are several considerations that must be addressed if the IEEE 1149.1A logic is not going to be used once the MCF5249 is assembled onto a board.

The prime consideration is to ensure that the IEEE 1149.1A test logic remains transparent and benign to the system logic during functional operation. This requires the minimum of either connecting the $\overline{\text{TRST}}$ pin to logic 0, or connecting the TCK clock pin to a clock source that will supply five rising edges and the falling edge after the fifth rising edge, to ensure that the part enters the test-logic-reset state. The recommended solution is to connect $\overline{\text{TRST}}$ to logic 0.

Another consideration is that the TCK pin does not have an internal pullup as is required on the TMS, TDI, and $\overline{\text{TRST}}$ pins; therefore, it should not be left unterminated to preclude mid-level input values. [Figure 20-3](#) shows pin values recommended for disabling JTAG with the MCF5249 in JTAG mode.

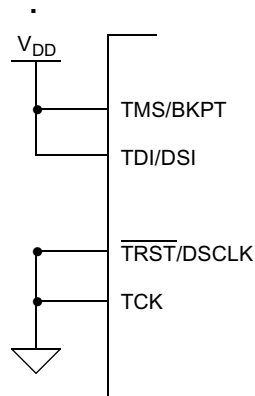

NOTE: test[3:0] SET TO '0001' ALLOWS JTAG MODE.

Figure 20-3 Disabling JTAG in JTAG Mode

A second method of using the MCF5249 without the IEEE 1149.1A logic being active is to select Debug mode by setting test[3:0]= 0001. The IEEE 1149.1A test controller is now placed in the test-logic-reset

state by the internal assertion of the $\overline{\text{TRST}}$ signal to the controller and the TAP pins function as Debug mode pins. While in JTAG mode, input pins TDI/DSI, TMS/BKPT, and $\overline{\text{TRST}}$ /DSCLK have internal pullups enabled. **Figure 20-4** shows pin values recommended for disabling JTAG with the MCF5249 in Debug mode.

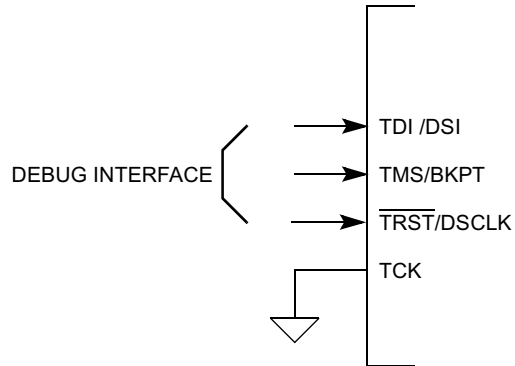

NOTE: test[3:0] NOT SET TO '0001' PROHIBITS JTAG.

Figure 20-4 Disabling JTAG in Debug Mode

20.7 MCF5249 BSDL FILE

```

-----
-- BSDL file for design XCF5249                --
-----
-- creation date Mon Oct 1 10:27:32 2001
-----
--
-- This information is provided on an AS IS basis and without warranty.  --
-- IN NO EVENT SHALL MOTOROLA BE LIABLE FOR INCIDENTAL OR CONSEQUENTIAL  --
-- DAMAGES ARISING FROM USE OF THIS INFORMATION. THIS DISCLAIMER OF      --
-- WARRANTY EXTENDS TO THE USER OF THE INFORMATION, AND TO THEIR CUSTOMERS --
-- OR USERS OF PRODUCTS AND IS IN LIEU OF ALL WARRANTIES WHETHER EXPRESS, --
-- IMPLIED, OR STATUTORY, INCLUDING IMPLIED WARRANTIES OF MERCHANTABILITY  --
-- OR FITNESS FOR PARTICULAR PURPOSE.                                     --
--
-- MOTOROLA does not represent or warrant that the information furnished  --
-- hereunder is free of infringement of any third party patents,          --
-- copyrights, trade secrets, or other intellectual property rights.      --
-- MOTOROLA does not represent or warrant that the information is free of  --
-- defect, or that it meets any particular standard, requirements or need  --
-- of the user of the information or their customers.                    --
--
-- MOTOROLA reserves the right to change the information in this file    --
-- without notice.
--
-----
--
-- Technical Note
--
-----

```

entity XCF5249 is

generic (PHYSICAL_PIN_MAP: string:= "BGA160");

```

port (
  scl_qspiclk_pin      : inout bit ;
  cs0_pin              : out  bit ;
  a21_pin              : out  bit ;
  a11_pin              : out  bit ;
  a10_pin              : out  bit ;
  a9_pin               : out  bit ;
  cmdsdio2_gp34_pin   : inout bit ;
  a18_pin              : out  bit ;
  a17_pin              : out  bit ;
  bclk_gp10_pin       : inout bit ;
  sclkout_gp15_pin    : inout bit ;
  bclke_pin           : out  bit ;
  sda_qspidin_pin     : inout bit ;
  data24_pin          : inout bit ;
  a22_pin              : out  bit ;
  sdudqm_pin          : out  bit ;
  ef_gp19_pin         : inout bit ;
  sdata0sdio1_gp54_pin : inout bit ;
  data25_pin          : inout bit ;
  data26_pin          : inout bit ;
  sdata2bs2_rsto_pin  : inout bit ;
  data27_pin          : inout bit ;
  data28_pin          : inout bit ;
  data29_pin          : inout bit ;
  sdata3_gp56_pin     : inout bit ;
  data30_pin          : inout bit ;
  bufenb1_gp57_pin    : inout bit ;
  data31_pin          : inout bit ;
  a13_pin              : out  bit ;
  a25_gpo8_pin        : out  bit ;
  a23_pin              : out  bit ;
  a14_pin              : out  bit ;
  a15_pin              : out  bit ;
  a16_pin              : out  bit ;
  a19_pin              : out  bit ;
  a20_pin              : out  bit ;
  qspics1_gp24_pin    : inout bit ;
  test2_pin           : in   bit ;
  sdramcs1_pin        : out  bit ;
  sdata1bs1_gp9_pin   : inout bit ;
  sdras_pin           : out  bit ;
  sdcas_pin           : out  bit ;
  sdwe_pin            : out  bit ;
  slddqm_pin          : out  bit ;
  gp5_pin             : inout bit ;
  qspics0_gp29_pin    : inout bit ;
  qspidout_gp26_pin   : inout bit ;
  gp6_pin             : inout bit ;
  data21_pin          : inout bit ;

```

```

data19_pin      : inout bit ;
qspics2_gp21_pin : inout bit ;
data20_pin      : inout bit ;
data22_pin      : inout bit ;
data18_pin      : inout bit ;
data23_pin      : inout bit ;
data17_pin      : inout bit ;
qspics3_gp22_pin : inout bit ;
data16_pin      : inout bit ;
sdramcs2_gp7_pin : inout bit ;
ebuout2_gpo37_pin : out bit ;
cflg_gp18_pin   : inout bit ;
ebuout1_gpo36_pin : out bit ;
ebuin3_adin0_gpi38_pin : in bit ;
ebuin2_gpi37_pin : in bit ;
scl2_gp3_pin    : inout bit ;
rsti_pin        : in bit ;
tout1_gpo35_pin : out bit ;
lrck2_gp44_pin  : inout bit ;
oe_pin          : out bit ;
sda2_gp55_pin   : inout bit ;
sdatao2_gpo41_pin : out bit ;
sclk2_gp48_pin  : inout bit ;
bufenb2_gp17_pin : inout bit ;
test3_pin       : in bit ;
sdatao1_gp25_pin : inout bit ;
lrck1_pin       : inout bit ;
lrck4_gp46_pin  : inout bit ;
sdatai4_gpi42_pin : in bit ;
sclk1_pin       : inout bit ;
sclk4_gp50_pin  : inout bit ;
ta_gp20_pin     : inout bit ;
sdatai1_pin     : in bit ;
ebuin1_gpi36_pin : in bit ;
PLLGVD          : linkage bit ;
PLLGGND         : linkage bit ;
PLL1GND         : linkage bit ;
PLL1VDD         : linkage bit ;
PLLCGND        : linkage bit ;
PLLCVDD        : linkage bit ;
idediow_gp14_pin : inout bit ;
crin_pin        : in bit ;
idedior_gp13_pin : inout bit ;
iordy_gp16_pin  : inout bit ;
cl11_gpo39_pin  : out bit ;
subr_gp53_pin   : inout bit ;
cl16_gpo42_pin  : out bit ;
xtrim_gpo38_pin : out bit ;
trst_dsclk_pin  : in bit ;
sfsy_gp52_pin   : inout bit ;
rw_b_pin        : out bit ;
rck_gp51_pin    : inout bit ;
tms_bkpt_pin    : in bit ;
tck_pin         : in bit ;

```

```

dbdcpst3_gp62_pin    : inout bit ;
cnpstclk_gp63_pin   : out  bit ;
dbdcpst1_gp60_pin   : inout bit ;
dbdcpst2_gp61_pin   : inout bit ;
dbdcpst0_gp59_pin   : inout bit ;
tdi_dsi_pin         : in   bit ;
test0_pin           : in   bit ;
tin0_gpi33_pin      : in   bit ;
hiz_b_pin           : in   bit ;
dbdcddata3_gp4_pin  : inout bit ;
tout0_gpo33_pin     : out  bit ;
dbdcddata1_gp1_pin  : inout bit ;
dbdcddata2_gp2_pin  : inout bit ;
cts2_adin3_gpi31_pin : in   bit ;
dbdcddata0_gp0_pin  : inout bit ;
rxd2_adin2_gpi28_pin : in   bit ;
tdo_dso_pin         : out  bit ;
rts2_gpo31_pin      : out  bit ;
sdatai3_gpi41_pin   : in   bit ;
cts1_gpi30_pin      : in   bit ;
txd2_gpo28_pin      : out  bit ;
rts1_gpo30_pin      : out  bit ;
ebuin4_adin1_gpi39_pin : in   bit ;
sre_gp11_pin        : inout bit ;
lrck3_gp45_pin      : inout bit ;
swe_gp12_pin        : inout bit ;
txd1_gpo27_pin      : out  bit ;
sclk3_gp49_pin      : inout bit ;
rxd1_gpi27_pin      : in   bit ;
cs1_gp58_pin        : inout bit ;
a1_pin              : out  bit ;
tin1_gp23_pin       : inout bit ;
a2_pin              : out  bit ;
a3_pin              : out  bit ;
a4_pin              : out  bit ;
a6_pin              : out  bit ;
a5_pin              : out  bit ;
a8_pin              : out  bit ;
a7_pin              : out  bit ;
a12_pin             : out  bit ;
test1_pin           : in   bit ;
GND33               : linkage bit_vector (0 to 2) ;
GND18               : linkage bit_vector (0 to 3) ;
VDD18               : linkage bit_vector (0 to 3) ;
VDD33               : linkage bit_vector (0 to 4) ;
);

```

```
use STD_1149_1_1994.all;
```

```
attribute COMPONENT_CONFORMANCE of XCF5249: entity is "STD_1149_1_1993";
```

```
attribute PIN_MAP of XCF5249: entity is PHYSICAL_PIN_MAP;
```

```
constant BGA160: PIN_MAP_STRING :=
```

```

"scl_qspiclk_pin      : D04 , " &
"cs0_pin             : A01 , " &
"a21_pin             : D03 , " &
"a11_pin             : B01 , " &
"a10_pin             : C02 , " &
"a9_pin              : C01 , " &
"cmdsdio2_gp34_pin   : E03 , " &
"a18_pin             : D02 , " &
"a17_pin             : D01 , " &
"bclk_gp10_pin       : E02 , " &
"sclkout_gp15_pin    : F03 , " &
"bclke_pin           : E01 , " &
"sda_qspidin_pin     : E04 , " &
"data24_pin           : F02 , " &
"a22_pin             : G03 , " &
"sdudqm_pin          : F01 , " &
"ef_gp19_pin         : F04 , " &
"sdata0sdio1_gp54_pin : G04 , " &
"data25_pin           : G01 , " &
"data26_pin           : G02 , " &
"sdata2bs2_rsto_pin  : H03 , " &
"data27_pin           : H01 , " &
"data28_pin           : H02 , " &
"data29_pin           : J01 , " &
"sdata3_gp56_pin     : J03 , " &
"data30_pin           : J02 , " &
"bufenb1_gp57_pin   : J04 , " &
"data31_pin           : K01 , " &
"a13_pin             : K02 , " &
"a25_gpo8_pin        : K03 , " &
"a23_pin             : K04 , " &
"a14_pin             : L01 , " &
"a15_pin             : L02 , " &
"a16_pin             : M01 , " &
"a19_pin             : M02 , " &
"a20_pin             : N01 , " &
"qspics1_gp24_pin    : L04 , " &
"test2_pin           : M03 , " &
"sdramcs1_pin        : N02 , " &
"sdata1bs1_gp9_pin   : M04 , " &
"sdras_pin           : P01 , " &
"sdcas_pin           : P02 , " &
"sdwe_pin            : N03 , " &
"sdlldqm_pin         : P03 , " &
"gp5_pin             : N04 , " &
"qspics0_gp29_pin    : P04 , " &
"qspidout_gp26_pin   : N05 , " &
"gp6_pin             : L05 , " &
"data21_pin           : P05 , " &
"data19_pin           : N06 , " &
"qspics2_gp21_pin    : L06 , " &
"data20_pin           : P06 , " &
"data22_pin           : L07 , " &
"data18_pin           : P07 , " &

```

```

"data23_pin      : K07, "&
"data17_pin      : N07, "&
"qspics3_gp22_pin : L08, "&
"data16_pin      : P08, "&
"sdracms2_gp7_pin : N08, "&
"ebuout2_gpo37_pin : P09, "&
"cfg_gp18_pin    : L09, "&
"ebuout1_gpo36_pin : N09, "&
"ebuin3_adin0_gpi38_pin : P10, "&
"ebuin2_gpi37_pin : N10, "&
"scl2_gp3_pin    : P11, "&
"rsti_pin        : P12, "&
"tout1_gpo35_pin : N11, "&
"lrck2_gp44_pin  : P13, "&
"oe_pin          : N12, "&
"sda2_gp55_pin   : M11, "&
"sdatao2_gpo41_pin : P14, "&
"sclk2_gp48_pin  : N13, "&
"bufenb2_gp17_pin : K11, "&
"test3_pin       : M12, "&
"sdatao1_gp25_pin : L12, "&
"lrck1_pin       : N14, "&
"lrck4_gp46_pin  : M13, "&
"sdatai4_gpi42_pin : M14, "&
"sclk1_pin        : L13, "&
"sclk4_gp50_pin  : L14, "&
"ta_gp20_pin     : L11, "&
"sdatai1_pin     : K13, "&
"ebuin1_gpi36_pin : K12, "&
"PLLGVD          : K14, "&
"PLLGND          : J11, "&
"PLL1GND         : J13, "&
"PLL1VDD         : J12, "&
"PLLCGND         : J14, "&
"PLLCVDD         : H11, "&
"idediow_gp14_pin : H12, "&
"crin_pin        : H14, "&
"idedior_gp13_pin : H13, "&
"iordy_gp16_pin  : G11, "&
"cl11_gpo39_pin  : G14, "&
"subr_gp53_pin   : G12, "&
"cl16_gpo42_pin  : G13, "&
"xtrim_gpo38_pin : F14, "&
"trst_dsclk_pin  : F11, "&
"sfsy_gp52_pin   : F13, "&
"rw_b_pin        : E14, "&
"rck_gp51_pin    : F12, "&
"tms_bkpt_pin    : E13, "&
"tck_pin         : E12, "&
"dbdcpst3_gp62_pin : D14, "&
"cnpstclk_gp63_pin : D13, "&
"dbdcpst1_gp60_pin : C14, "&
"dbdcpst2_gp61_pin : C13, "&
"dbdcpst0_gp59_pin : B14, "&

```

```

"tdi_dsi_pin      : D11 , " &
"test0_pin       : C12 , " &
"tin0_gpi33_pin  : B13 , " &
"hiz_b_pin       : C11 , " &
"dbdcddata3_gp4_pin  : A14 , " &
"tout0_gpo33_pin  : A13 , " &
"dbdcddata1_gp1_pin  : B12 , " &
"dbdcddata2_gp2_pin  : A12 , " &
"cts2_adin3_gpi31_pin  : B11 , " &
"dbdcddata0_gp0_pin  : A11 , " &
"rxd2_adin2_gpi28_pin  : B10 , " &
"tdo_dso_pin     : D10 , " &
"rts2_gpo31_pin  : A10 , " &
"sdatai3_gpi41_pin  : B09 , " &
"cts1_gpi30_pin   : D09 , " &
"txd2_gpo28_pin  : A09 , " &
"rts1_gpo30_pin   : D08 , " &
"ebuin4_adin1_gpi39_pin  : A08 , " &
"sre_gp11_pin     : E08 , " &
"lrck3_gp45_pin  : B08 , " &
"swe_gp12_pin     : E07 , " &
"txd1_gpo27_pin  : D07 , " &
"sclk3_gp49_pin   : A07 , " &
"rxd1_gpi27_pin  : B07 , " &
"cs1_gp58_pin    : A06 , " &
"a1_pin          : B06 , " &
"tin1_gp23_pin   : D06 , " &
"a2_pin          : A05 , " &
"a3_pin          : B05 , " &
"a4_pin          : A04 , " &
"a6_pin          : A03 , " &
"a5_pin          : B04 , " &
"a8_pin          : A02 , " &
"a7_pin          : B03 , " &
"a12_pin         : B02 , " &
"test1_pin       : C03 , " &
"GND33           : (H04,E11,D05) , " &
"GND18           : (K06,L10,E09,C04) , " &
"VDD18           : (K05,K09,E10,E06) , " &
"VDD33           : (L03,K08,K10,D12,E05) " ;

```

```

attribute TAP_SCAN_CLOCK of tck_pin      : signal is (1.00e+07, BOTH);
attribute TAP_SCAN_MODE of tms_bkpt_pin  : signal is true;
attribute TAP_SCAN_IN of tdi_dsi_pin     : signal is true;
attribute TAP_SCAN_OUT of tdo_dso_pin    : signal is true;
attribute TAP_SCAN_RESET of trst_dsclk_pin : signal is true;

```

```

-- compliance pattern (forced value is required for correct --
-- JTAG operation) --
-- * specified pins are not allowed to by part of the BSR --
attribute COMPLIANCE_PATTERNS of XCF5249: entity is
"(test3_pin, test2_pin, test1_pin, test0_pin, hiz_b_pin) (00001)";

```

```

attribute INSTRUCTION_LENGTH of XCF5249 : entity is 4;

```



```

attribute INSTRUCTION_OPCODE of XCF5249 : entity is
  "EXTEST    (0000)," & -- required by standard
  "IDCODE    (0001)," & -- required by standard
  "SAMPLE    (0010)," & -- required by standard
  "HIGHZ     (0100)," & -- optional instruction)
  "RINGOSC   (0111)," & -- privat instruction
  "ORGATE    (1000)," & -- privat instruction
  "BYPASS    (1111)" ; -- required by standard

-- instruction loaded during capture IR state      --
-- * least significant bits must be "01"          --
attribute INSTRUCTION_CAPTURE of XCF5249 : entity is "0001";

-- PRIVAT instruction: privat and potential unsave to use --
--           by others than the manufacturer           --
attribute INSTRUCTION_PRIVATE of XCF5249 : entity is
  "RINGOSC," &
  "ORGATE" ;

attribute IDCODE_REGISTER of XCF5249 : entity is
  "0010" &           -- version number
  "010101" &        -- part number (part 1 (design center))
  "00000001110" &   -- part number (part 2 (chip id))
  "00000001110" &   -- manufacturer id
  "1" ;             -- required by standard

-- BSR specification ('0' is the cell closest to TDO) --
attribute BOUNDARY_LENGTH of XCF5249: entity is 242;

attribute BOUNDARY_REGISTER of XCF5249: entity is
-- num cell port      function      safe [ccell disval rslt ]
"0 (BC_2, *,          control, 0 )," &
"1 (BC_7, dbdcpst0_gp59_pin,  bidir,  X, 0, 0, Z )," &
"2 (BC_2, *,          control, 0 )," &
"3 (BC_7, dbdcpst2_gp61_pin,  bidir,  X, 2, 0, Z )," &
"4 (BC_2, *,          control, 0 )," &
"5 (BC_7, dbdcpst1_gp60_pin,  bidir,  X, 4, 0, Z )," &
"6 (BC_2, *,          control, 0 )," &
"7 (BC_2, cnpstclk_gp63_pin,  output3, X, 6, 0, Z )," &
"8 (BC_2, *,          control, 0 )," &
"9 (BC_7, dbdcpst3_gp62_pin,  bidir,  X, 8, 0, Z )," &
"10 (BC_2, *,         control, 0 )," &
"11 (BC_7, rck_gp51_pin,     bidir,   X, 10, 0, Z )," &
"12 (BC_2, *,          control, 0 )," &
"13 (BC_2, rw_b_pin,        output3, X, 12, 0, Z )," &
"14 (BC_2, *,          control, 0 )," &
"15 (BC_7, sfsy_gp52_pin,    bidir,   X, 14, 0, Z )," &
"16 (BC_2, *,          control, 0 )," &
"17 (BC_2, xtrim_gpo38_pin,  output3, X, 16, 0, Z )," &
"18 (BC_2, *,          control, 0 )," &
"19 (BC_2, cl16_gpo42_pin,   output3, X, 18, 0, Z )," &
"20 (BC_2, *,          control, 0 )," &
"21 (BC_7, subr_gp53_pin,    bidir,   X, 20, 0, Z )," &

```

```

"22 (BC_2, *,          control, 0 )," &
"23 (BC_2, cl11_gpo39_pin, output3, X, 22, 0, Z )," &
"24 (BC_2, *,          control, 0 )," &
"25 (BC_7, iordy_gp16_pin, bidir, X, 24, 0, Z )," &
"26 (BC_2, *,          control, 0 )," &
"27 (BC_7, idedior_gp13_pin, bidir, X, 26, 0, Z )," &
"28 (BC_4, crin_pin,    clock, X )," &
"29 (BC_2, *,          control, 0 )," &
"30 (BC_7, idediow_gp14_pin, bidir, X, 29, 0, Z )," &
"31 (BC_4, ebuin1_gpi36_pin, input, X )," &
"32 (BC_4, sdatai1_pin, input, X )," &
"33 (BC_2, *,          control, 0 )," &
"34 (BC_7, ta_gp20_pin, bidir, X, 33, 0, Z )," &
"35 (BC_2, *,          control, 0 )," &
"36 (BC_7, sclk4_gp50_pin, bidir, X, 35, 0, Z )," &
"37 (BC_2, *,          control, 0 )," &
"38 (BC_7, sclk1_pin,  bidir, X, 37, 0, Z )," &
"39 (BC_4, sdatai4_gpi42_pin, input, X )," &
"40 (BC_2, *,          control, 0 )," &
"41 (BC_7, lrck4_gp46_pin, bidir, X, 40, 0, Z )," &
"42 (BC_2, *,          control, 0 )," &
"43 (BC_7, lrck1_pin,  bidir, X, 42, 0, Z )," &
"44 (BC_2, *,          control, 0 )," &
"45 (BC_7, sdatao1_gp25_pin, bidir, X, 44, 0, Z )," &
"46 (BC_2, *,          control, 0 )," &
"47 (BC_7, bufenb2_gp17_pin, bidir, X, 46, 0, Z )," &
"48 (BC_2, *,          control, 0 )," &
"49 (BC_7, sclk2_gp48_pin, bidir, X, 48, 0, Z )," &
"50 (BC_2, *,          control, 0 )," &
"51 (BC_2, sdatao2_gpo41_pin, output3, X, 50, 0, Z )," &
"52 (BC_2, *,          control, 0 )," &
"53 (BC_7, sda2_gp55_pin, bidir, X, 52, 0, Z )," &
"54 (BC_2, *,          control, 0 )," &
"55 (BC_2, oe_pin,     output3, X, 54, 0, Z )," &
"56 (BC_2, *,          control, 0 )," &
"57 (BC_7, lrck2_gp44_pin, bidir, X, 56, 0, Z )," &
"58 (BC_2, *,          control, 0 )," &
"59 (BC_2, tout1_gpo35_pin, output3, X, 58, 0, Z )," &
"60 (BC_4, rsti_pin,   input, X )," &
"61 (BC_2, *,          control, 0 )," &
"62 (BC_7, scl2_gp3_pin, bidir, X, 61, 0, Z )," &
"63 (BC_4, ebuin2_gpi37_pin, input, X )," &
"64 (BC_4, ebuin3_adin0_gpi38_pin, input, X )," &
"65 (BC_2, *,          control, 0 )," &
"66 (BC_2, ebuout1_gpo36_pin, output3, X, 65, 0, Z )," &
"67 (BC_2, *,          control, 0 )," &
"68 (BC_7, cfg_gp18_pin, bidir, X, 67, 0, Z )," &
"69 (BC_2, *,          control, 0 )," &
"70 (BC_2, ebuout2_gpo37_pin, output3, X, 69, 0, Z )," &
"71 (BC_2, *,          control, 0 )," &
"72 (BC_7, sdramcs2_gp7_pin, bidir, X, 71, 0, Z )," &
"73 (BC_2, *,          control, 0 )," &
"74 (BC_7, data16_pin, bidir, X, 73, 0, Z )," &
"75 (BC_2, *,          control, 0 )," &

```

```

"76 (BC_7, qspics3_gp22_pin,  bidir,  X, 75, 0, Z )," &
"77 (BC_2, *,                control, 0 )," &
"78 (BC_7, data17_pin,      bidir,  X, 77, 0, Z )," &
"79 (BC_2, *,                control, 0 )," &
"80 (BC_7, data23_pin,      bidir,  X, 79, 0, Z )," &
"81 (BC_2, *,                control, 0 )," &
"82 (BC_7, data18_pin,      bidir,  X, 81, 0, Z )," &
"83 (BC_2, *,                control, 0 )," &
"84 (BC_7, data22_pin,      bidir,  X, 83, 0, Z )," &
"85 (BC_2, *,                control, 0 )," &
"86 (BC_7, data20_pin,      bidir,  X, 85, 0, Z )," &
"87 (BC_2, *,                control, 0 )," &
"88 (BC_7, qspics2_gp21_pin, bidir,  X, 87, 0, Z )," &
"89 (BC_2, *,                control, 0 )," &
"90 (BC_7, data19_pin,      bidir,  X, 89, 0, Z )," &
"91 (BC_2, *,                control, 0 )," &
"92 (BC_7, data21_pin,      bidir,  X, 91, 0, Z )," &
"93 (BC_2, *,                control, 0 )," &
"94 (BC_7, gp6_pin,         bidir,  X, 93, 0, Z )," &
"95 (BC_2, *,                control, 0 )," &
"96 (BC_7, qspidout_gp26_pin, bidir,  X, 95, 0, Z )," &
"97 (BC_2, *,                control, 0 )," &
"98 (BC_7, qspics0_gp29_pin, bidir,  X, 97, 0, Z )," &
"99 (BC_2, *,                control, 0 )," &
"100 (BC_7, gp5_pin,        bidir,  X, 99, 0, Z )," &
"101 (BC_2, *,              control, 0 )," &
"102 (BC_2, slddqmq_pin,    output3, X, 101, 0, Z )," &
"103 (BC_2, *,              control, 0 )," &
"104 (BC_2, sdwe_pin,       output3, X, 103, 0, Z )," &
"105 (BC_2, *,              control, 0 )," &
"106 (BC_2, sdcas_pin,      output3, X, 105, 0, Z )," &
"107 (BC_2, *,              control, 0 )," &
"108 (BC_2, sdras_pin,     output3, X, 107, 0, Z )," &
"109 (BC_2, *,              control, 0 )," &
"110 (BC_7, sdata1bs1_gp9_pin, bidir,  X, 109, 0, Z )," &
"111 (BC_2, *,              control, 0 )," &
"112 (BC_2, sdramcs1_pin,   output3, X, 111, 0, Z )," &
"113 (BC_2, *,              control, 0 )," &
"114 (BC_7, qspics1_gp24_pin, bidir,  X, 113, 0, Z )," &
"115 (BC_2, *,              control, 0 )," &
"116 (BC_2, a20_pin,        output3, X, 115, 0, Z )," &
"117 (BC_2, *,              control, 0 )," &
"118 (BC_2, a19_pin,        output3, X, 117, 0, Z )," &
"119 (BC_2, *,              control, 0 )," &
"120 (BC_2, a16_pin,        output3, X, 119, 0, Z )," &
"121 (BC_2, *,              control, 0 )," &
"122 (BC_2, a15_pin,        output3, X, 121, 0, Z )," &
"123 (BC_2, *,              control, 0 )," &
"124 (BC_2, a14_pin,        output3, X, 123, 0, Z )," &
"125 (BC_2, *,              control, 0 )," &
"126 (BC_2, a23_pin,        output3, X, 125, 0, Z )," &
"127 (BC_2, *,              control, 0 )," &
"128 (BC_2, a25_gpo8_pin,   output3, X, 127, 0, Z )," &
"129 (BC_2, *,              control, 0 )," &

```

```

"130 (BC_2, a13_pin,      output3,  X, 129, 0,  Z )," &
"131 (BC_2, *,          control,  0 )," &
"132 (BC_7, data31_pin,  bidir,   X, 131, 0,  Z )," &
"133 (BC_2, *,          control,  0 )," &
"134 (BC_7, bufenb1_gp57_pin, bidir,   X, 133, 0,  Z )," &
"135 (BC_2, *,          control,  0 )," &
"136 (BC_7, data30_pin,  bidir,   X, 135, 0,  Z )," &
"137 (BC_2, *,          control,  0 )," &
"138 (BC_7, sdata3_gp56_pin, bidir,   X, 137, 0,  Z )," &
"139 (BC_2, *,          control,  0 )," &
"140 (BC_7, data29_pin,  bidir,   X, 139, 0,  Z )," &
"141 (BC_2, *,          control,  0 )," &
"142 (BC_7, data28_pin,  bidir,   X, 141, 0,  Z )," &
"143 (BC_2, *,          control,  0 )," &
"144 (BC_7, data27_pin,  bidir,   X, 143, 0,  Z )," &
"145 (BC_2, *,          control,  0 )," &
"146 (BC_7, sdata2bs2_rsto_pin, bidir,   X, 145, 0,  Z )," &
"147 (BC_2, *,          control,  0 )," &
"148 (BC_7, data26_pin,  bidir,   X, 147, 0,  Z )," &
"149 (BC_2, *,          control,  0 )," &
"150 (BC_7, data25_pin,  bidir,   X, 149, 0,  Z )," &
"151 (BC_2, *,          control,  0 )," &
"152 (BC_7, sdata0sdio1_gp54_pin, bidir,   X, 151, 0,  Z )," &
"153 (BC_2, *,          control,  0 )," &
"154 (BC_7, ef_gp19_pin,  bidir,   X, 153, 0,  Z )," &
"155 (BC_2, *,          control,  0 )," &
"156 (BC_2, sdudqm_pin,  output3,  X, 155, 0,  Z )," &
"157 (BC_2, *,          control,  0 )," &
"158 (BC_2, a22_pin,     output3,  X, 157, 0,  Z )," &
"159 (BC_2, *,          control,  0 )," &
"160 (BC_7, data24_pin,  bidir,   X, 159, 0,  Z )," &
"161 (BC_2, *,          control,  0 )," &
"162 (BC_7, sda_qspidin_pin, bidir,   X, 161, 0,  Z )," &
"163 (BC_2, *,          control,  0 )," &
"164 (BC_2, bclke_pin,   output3,  X, 163, 0,  Z )," &
"165 (BC_2, *,          control,  0 )," &
"166 (BC_7, sclkout_gp15_pin, bidir,   X, 165, 0,  Z )," &
"167 (BC_2, *,          control,  0 )," &
"168 (BC_7, bclk_gp10_pin, bidir,   X, 167, 0,  Z )," &
"169 (BC_2, *,          control,  0 )," &
"170 (BC_2, a17_pin,     output3,  X, 169, 0,  Z )," &
"171 (BC_2, *,          control,  0 )," &
"172 (BC_2, a18_pin,     output3,  X, 171, 0,  Z )," &
"173 (BC_2, *,          control,  0 )," &
"174 (BC_7, cmdsdio2_gp34_pin, bidir,   X, 173, 0,  Z )," &
"175 (BC_2, *,          control,  0 )," &
"176 (BC_2, a9_pin,      output3,  X, 175, 0,  Z )," &
"177 (BC_2, *,          control,  0 )," &
"178 (BC_2, a10_pin,     output3,  X, 177, 0,  Z )," &
"179 (BC_2, *,          control,  0 )," &
"180 (BC_2, a11_pin,     output3,  X, 179, 0,  Z )," &
"181 (BC_2, *,          control,  0 )," &
"182 (BC_2, a21_pin,     output3,  X, 181, 0,  Z )," &
"183 (BC_2, *,          control,  0 )," &

```

```

"184 (BC_2, cs0_pin,      output3,  X, 183, 0,  Z )," &
"185 (BC_2, *,          control,  0 )," &
"186 (BC_7, scl_qspiclk_pin,  bidir,   X, 185, 0,  Z )," &
"187 (BC_2, *,          control,  0 )," &
"188 (BC_2, a12_pin,     output3,  X, 187, 0,  Z )," &
"189 (BC_2, *,          control,  0 )," &
"190 (BC_2, a7_pin,      output3,  X, 189, 0,  Z )," &
"191 (BC_2, *,          control,  0 )," &
"192 (BC_2, a8_pin,      output3,  X, 191, 0,  Z )," &
"193 (BC_2, *,          control,  0 )," &
"194 (BC_2, a5_pin,      output3,  X, 193, 0,  Z )," &
"195 (BC_2, *,          control,  0 )," &
"196 (BC_2, a6_pin,      output3,  X, 195, 0,  Z )," &
"197 (BC_2, *,          control,  0 )," &
"198 (BC_2, a4_pin,      output3,  X, 197, 0,  Z )," &
"199 (BC_2, *,          control,  0 )," &
"200 (BC_2, a3_pin,      output3,  X, 199, 0,  Z )," &
"201 (BC_2, *,          control,  0 )," &
"202 (BC_2, a2_pin,      output3,  X, 201, 0,  Z )," &
"203 (BC_2, *,          control,  0 )," &
"204 (BC_7, tin1_gp23_pin,  bidir,   X, 203, 0,  Z )," &
"205 (BC_2, *,          control,  0 )," &
"206 (BC_2, a1_pin,      output3,  X, 205, 0,  Z )," &
"207 (BC_2, *,          control,  0 )," &
"208 (BC_7, cs1_gp58_pin,  bidir,   X, 207, 0,  Z )," &
"209 (BC_4, rxd1_gpi27_pin, input,    X )," &
"210 (BC_2, *,          control,  0 )," &
"211 (BC_7, sclk3_gp49_pin, bidir,   X, 210, 0,  Z )," &
"212 (BC_2, *,          control,  0 )," &
"213 (BC_2, txd1_gpo27_pin, output3,  X, 212, 0,  Z )," &
"214 (BC_2, *,          control,  0 )," &
"215 (BC_7, swe_gp12_pin,  bidir,   X, 214, 0,  Z )," &
"216 (BC_2, *,          control,  0 )," &
"217 (BC_7, lrck3_gp45_pin, bidir,   X, 216, 0,  Z )," &
"218 (BC_2, *,          control,  0 )," &
"219 (BC_7, sre_gp11_pin,  bidir,   X, 218, 0,  Z )," &
"220 (BC_4, ebuin4_adin1_gpi39_pin, input,    X )," &
"221 (BC_2, *,          control,  0 )," &
"222 (BC_2, rts1_gpo30_pin, output3,  X, 221, 0,  Z )," &
"223 (BC_2, *,          control,  0 )," &
"224 (BC_2, txd2_gpo28_pin, output3,  X, 223, 0,  Z )," &
"225 (BC_4, cts1_gpi30_pin, input,    X )," &
"226 (BC_4, sdatai3_gpi41_pin, input,    X )," &
"227 (BC_2, *,          control,  0 )," &
"228 (BC_2, rts2_gpo31_pin, output3,  X, 227, 0,  Z )," &
"229 (BC_4, rxd2_adin2_gpi28_pin, input,    X )," &
"230 (BC_2, *,          control,  0 )," &
"231 (BC_7, dbdcddata0_gp0_pin, bidir,   X, 230, 0,  Z )," &
"232 (BC_4, cts2_adin3_gpi31_pin, input,    X )," &
"233 (BC_2, *,          control,  0 )," &
"234 (BC_7, dbdcddata2_gp2_pin, bidir,   X, 233, 0,  Z )," &
"235 (BC_2, *,          control,  0 )," &
"236 (BC_7, dbdcddata1_gp1_pin, bidir,   X, 235, 0,  Z )," &
"237 (BC_2, *,          control,  0 )," &

```

Obtaining the IEEE 1149.1A Standard

```
"238 (BC_2, tout0_gpo33_pin, output3, X, 237, 0, Z )," &  
"239 (BC_2, *, control, 0 )," &  
"240 (BC_7, dbdcddata3_gp4_pin, bidir, X, 239, 0, Z )," &  
"241 (BC_4, tin0_gpi33_pin, input, X )";
```

end XCF5249;

20.8 OBTAINING THE IEEE 1149.1A STANDARD

The IEEE 1149 Standard JTAG specification is a copyrighted document and must be obtained directly from the IEEE:

IEEE Standards Department
445 Hoes Lane
P.O. Box 1331
Piscataway, NJ 08855-1331
USA

<http://stdsbbs.ieee.org/>

Fax: 908-981-9667

Information: 908-981-0060 or 1-800-678-4333

Section 21

Electrical Specifications

Table 21-1 Maximum Ratings

RATING	SYMBOL	VALUE	UNITS
Supply Core Voltage	V_{CC}	-0.5 to +2.5	V
Maximum Core Operating Voltage	V_{CC}	+1.98	V
Minimum Core Operating Voltage	V_{CC}	+1.62	V
Supply I/O Voltage	V_{CC}	-0.5 to +4.6	V
Maximum I/O Operating Voltage	V_{CC}	+3.6	V
Minimum I/O Operating Voltage	V_{CC}	+3.0	V
Input Voltage	V_{in}	-0.5 to +6.0	V
Storage Temperature Range	T_{stg}	-65 to 150	°C

Table 21-2 Operating Temperature

CHARACTERISTIC	SYMBOL	VALUE	UNITS
Maximum Operating Ambient Temperature	T_{Amax}	85 ¹	°C
Minimum Operating Ambient Temperature	T_{Amin}	0	°C

1. This published maximum operating ambient temperature should be used only as a system design guideline. All device operating parameters are guaranteed only when the junction temperature does not exceed 105°C.

Table 21-3 DC Electrical Specifications (V_{cc} = 3.3 Vdc ± 0.3 Vdc)

CHARACTERISTIC	SYMBOL	MIN	MAX	UNITS
Operation Voltage Range	V _{cc}	3.0	3.6	V
Input High Voltage	V _{IH}	2	5.5	V
Input Low Voltage	V _{IL}	-0.3	0.8	V
Input Leakage Current @ 0.0V /3.3 V During Normal Operation	I _{in}	-	±1	μA
Hi-Impedance (Three-State) Leakage Current @ 0.0V/3.3 V During Normal Operation	I _{TSI}	-	±1	μA
Output High Voltage I _{OH} = 8mA ¹ , 4mA ² , 2mA ³	V _{OH}	2.4	-	V
Output Low Voltage I _{OL} = 8mA ¹ , 4mA ² , 2mA ³	V _{OL}	-	0.4	V
Schmitt Trigger Low to High Threshold Point ⁶	V _{T+}	1.47	-	V
Schmitt Trigger High to Low Threshold Point ⁶	V _{T-}	-	.95	V
Load Capacitance (DATA[31:16], DCL0, DCL1, SCLK[4:1], SCLKOUT, EBUOUT[2:1], LRCK[4:1], SDATAO[2:1], CFLG, EF, DBCDDATA[3:0], DBDCPST[3:0], CNPSTCLK, IDEDIOR, IDEDIOR, IORDY, SRE, SWE)	C _L	-	50	pF
Load Capacitance (ADDR[25,23:9], SCLK)	C _L	-	40	pF
Load Capacitance (BCLKE, SDCAS, SDRAS, SDLDQM, SDRAMCS[2:1], SDUDQM, SDWE, BUFENB[2:1])	C _L	-	30	pF
Load Capacitance (SDA, SDA2, SCL, SCL2, CMDSDIO2, SDATA2BS2, SDATA1BS1, SDATA0SDIO1, CS[1:0], OE, R/W, TA, TXD[2:1], XTRIM, TDO/DSO, RCK, SFSY, SUBR, SDATA3, TOUT[1:0], QSPIDOUT, QSPICS[3:0], GP[6:5])	C _L	-	20	pF
Capacitance ⁵ , V _{in} = 0 V, f = 1 MHz	C _{IN}	-	6	pF

1. DATA[31:16], ADDR[25,23:9], PSTCLK, SCLK
2. SCL, SDA, PST[3:0], DDATA[3:0], TDSO, SDRAS, SDCAS, SDWE, SDRAMCS[2:1], SDLDQM, SDUDQM, R/W
3. TOUT[1:0], RTS[2:1], TXD[2:1], SCLK[4:1]
4. BKPT/TMS, DSI/TDI, DSCLK/TRST
5. Capacitance C_{IN} is periodically sampled rather than 100% tested.
6. SCLK[4:1], SCL, SCL2, SDA, SDA2, CRIN, RST1

21.1 SUPPLY VOLTAGE SEQUENCING AND SEPARATION CAUTIONS

Figure 21-1 shows two situations to avoid in sequencing the CoreVdd and PADVdd (I/O) and PLL supplies.

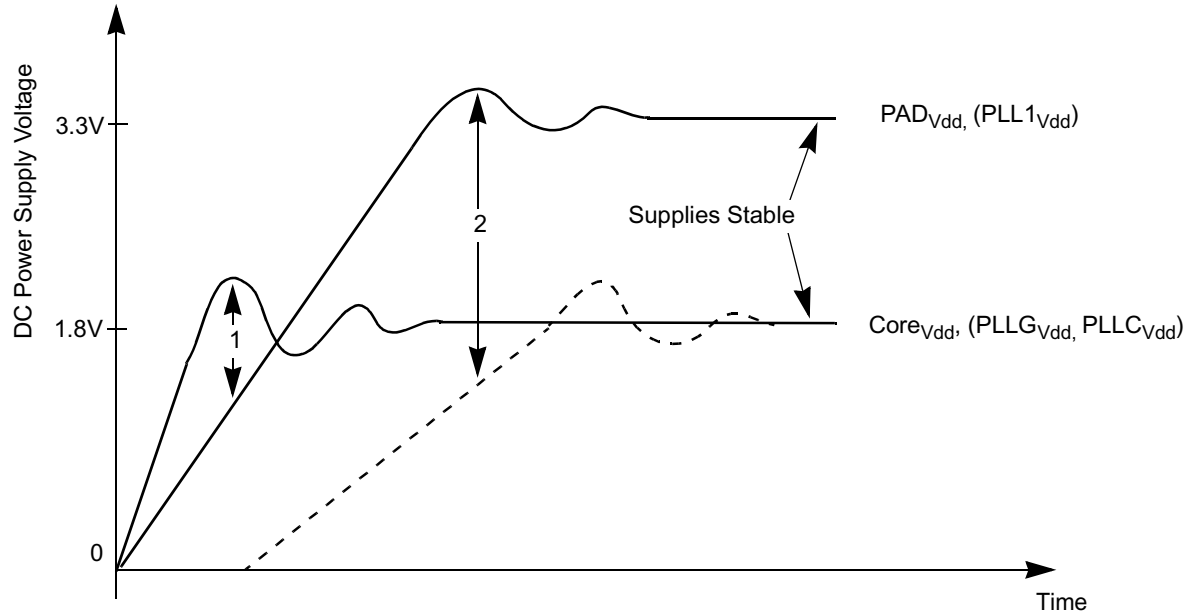

Notes:

- 1 I_{CoreVdd}, PLLG_{Vdd}, PLLC_{Vdd}V_{cc}, PV_{cc} rising before PAD_{Vdd}, PLL1_{Vdd}
- 2 PAD_{Vdd}, PLL1_{Vdd} rising much faster than Core_{Vdd}, PLLG_{Vdd}, PLLC_{Vdd}

Figure 21-1 Supply Voltage Sequencing and Separation Cautions

CoreVdd supply should not be allowed to rise early (1). This is usually avoided by running the regulator for the CoreVdd supply (1.8 V) from the voltage generated by the 3.3V supply (PADVdd) (See Figure 5-2). This keeps the CoreVdd supply from rising faster than PADVdd supply.

Also CoreVdd, PLLGVdd, PLLCVdd supply should not rise so late that a large voltage difference is allowed between the two supplies (2). Typically this situation is avoided by using external discrete diodes in series between supplies as shown in Figure 21-2. The series diodes forward bias when the difference between PADVdd and CoreVdd reaches approximately 2.1V, causing CoreVdd to rise as PADVdd ramps up. When the CoreVdd regulator begins proper operation, the difference between supplies should not exceed 1.5 V and conduction through the diode chain reduces to essentially leakage current.

During supply sequencing, the following general relationship should be adhered to: PADVdd, >= CoreVdd, PLLGVdd, >= (PADVdd - 2.1 V).

The PLL core supplies (PLLGvdd and PLLCvdd) should comply with these constraints just as the CoreVdd does. In practice, PLLGVdd and PLLCVdd are typically connected directly to the CoreVdd with some filtering. Further, the PLL PAD supply (PLL1VDD) would be connected directly to the PAD supply via some filtering.

Freescale Semiconductor, Inc.

Supply Voltage Sequencing and Separation Cautions

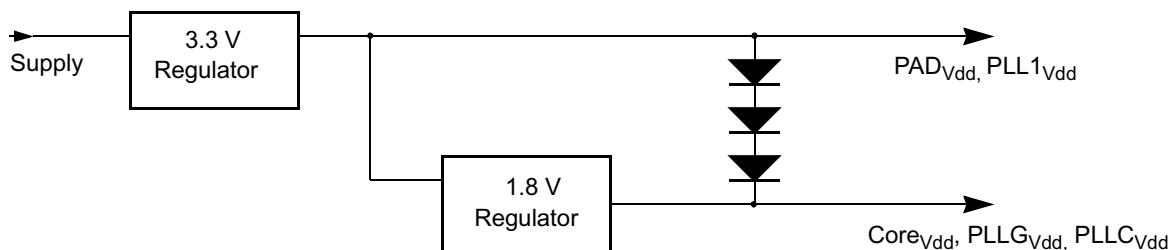

Figure 21-2 Example Circuit to Control Supply Sequencing

When a DC-DC converter is used in the system to generate the 1.8V supply, additional care is required. If possible, the 1.8V DC-DC converter should be supplied by the 3.3V supply. If this is impossible or considered inefficient, the designer needs to ensure that the rise time of the 1.8V supply still complies with the recommendations stated above. Adding the 3 diodes as shown in [Figure 21-2](#) will help resolve issues associated with a slow rise time of the 1.8V supply. Further, a Schottky diode could be added between the supplies, which would have the effect of holding the 1.8V supply to match the 3.3V supply should the 1.8V supply come-up first. This diode also has the function of ensuring that there is not a large voltage differential between the Core supply and the PAD supply during power-down. See [Figure 21-3](#) below.

Refer to the *M5249C3 Reference Board User's Manual* for the recommended diode types.

A further note is the recommendation for hard resetting of the device. Motorola recommends using a dynamic reset circuit. This allows for control of the voltage at which the reset will be released and ensures that the correct voltage level at the RESET pin is achieved in all cases. Passive (RC) reset networks do not always achieve the desired results.

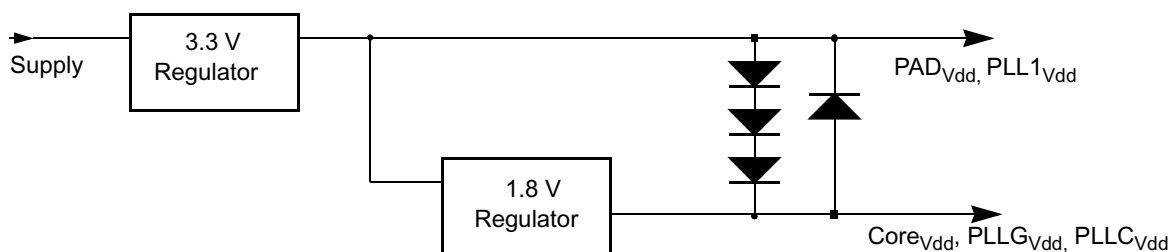

Figure 21-3 MCF5249 Power Supply

Note: The following signals are not available on the 144 QFP package.

Table 21-4 160 MAPBGA Ball Assignments

160MAPBGA BALL NUMBER	FUNCTION	GPIO
E3	CMD_SDIO2	GPIO34
G4	SDATA0_SDIO1	GPIO54
H3	RSTO/SDATA2_BS2	
K3	A25	GPO8
L4	QSPI_CS1	GPIO24
L8	QSPI_CS3	GPIO22
N8	SDRAM_CS2	GPIO7
P9	EBUOUT2	GPO 37
K11	BUFENB2	GPIO17
G12	SUBR	GPIO 53
F13	SFSY	GPIO 52
F12	RCK	GPIO 51
E8	SRE	GPIO11
B8	LRCK3	GPIO 45
E7	SWE	GPIO12
A7	SCLK3	GPIO 49

Table 21-5 Clock Timing Specification

NUM	CHARACTERISTIC			UNITS
		MIN	MAX	
	CRIN Frequency ¹	11.29	33.86	MHz
C5	PSTCLK cycle time	7.1	—	nSec
C6	PSTCLK duty cycle	40	60	%
C7	SCLK cycle time	14.2	—	nSec
C8	SCLK duty cycle	45	55	%

¹ There are only three choices for the valid Audio frequencies 11.29 MHz, 16.93 MHz, or 33.86 MHz; no other values are allowed. The System Clock is derived from one of these crystals via an internal PLL.

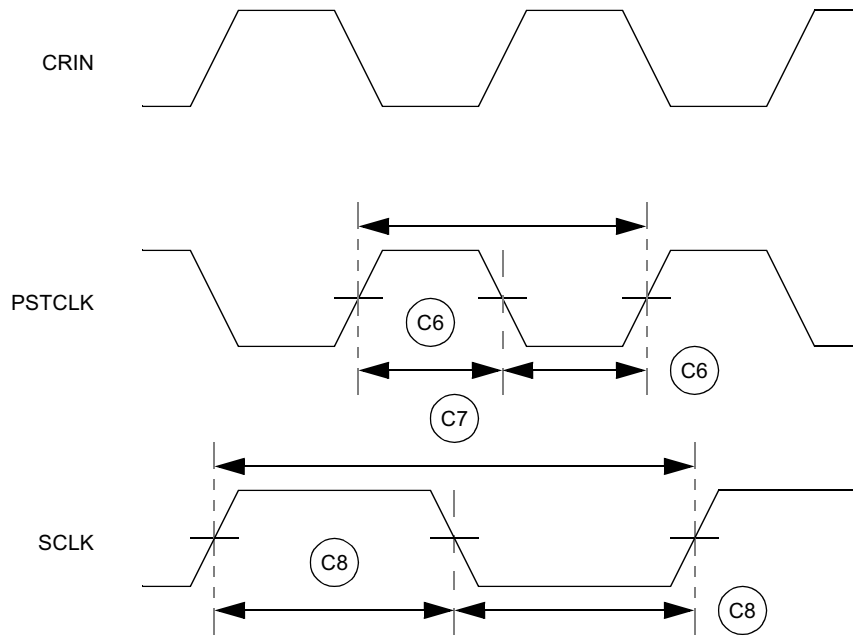

Figure 21-4 Clock Timing Definition

Note: Signals above are shown in relation to the clock. No relationship between signals is implied or intended.

21.1.1 PROCESSOR BUS INPUT TIMING SPECIFICATIONS

Table 21-6 lists processor bus input timings.

NOTE

All processor bus timings are synchronous; that is, input setup/hold and output delay with respect to the rising edge of a reference clock. The reference clock is the SCLK output.

All other timing relationships can be derived from these values.

Table 21-6 External Bus Input Timing Specifications

NAME	CHARACTERISTIC ^A	SYMBOL	MIN	MAX	UNIT
B0	SCLK	tCYC	14.26	—	ns
Control Inputs					
B1	Control input valid to SCLK high ^b	tCVCH	10	—	ns
B2	SCLK high to control inputs invalid ^b .	tCHCII	2	—	ns
Data Inputs					
B4	Data input (D[31:0]) valid to SCLK high	tDIVCH	6	—	ns
B5	SCLK high to data input (D[31:0]) invalid	tCHDII	2	—	ns

a. Timing specifications have been indicated taking into account the full drive strength for the pads.

b. TA pin is being referred to as control input.

21.1.2 PROCESSOR BUS OUTPUT TIMING SPECIFICATIONS

Table 21-7 lists processor bus output timings.

Table 21-7 External Bus Output Timing Specifications

NAME	CHARACTERISTIC	SYMBOL	MIN	MAX	UNIT
Control Outputs					
B6a	SCLK high to chip selects valid ^a	t_{CHCV}	—	$0.5t_{CYC} + 10$	ns
B6b	SCLK high to output enable (\overline{OE}) valid ^b	t_{CHOV}	—	$0.5t_{CYC} + 10$	ns
B7a	SCLK high to control output (\overline{OE}) invalid	t_{CHCOI}	$0.5t_{CYC} + 2$	—	ns
B7b	SCLK high to chip selects invalid	t_{CHCI}	$0.5t_{CYC} + 2$	—	ns
Address and Attribute Outputs					
B8	SCLK high to address (A[23:1]) and control ($\overline{R/W}$) valid	t_{CHAV}	—	10	ns
B9	SCLK high to address (A[23:1]) and control ($\overline{R/W}$) invalid	t_{CHAI}	2	—	ns
Data Outputs					
B11	SCLK high to data output (D[31:16]) valid	t_{CHDOV}	—	10	ns
B12	SCLK high to data output (D[31:16]) invalid	t_{CHDOI}	2	—	ns
B13	SCLK high to data output (D[31:16]) high impedance	t_{CHDOZ}	—	14	ns

- a. \overline{CSn} transitions after the falling edge of SCLK.
b. \overline{OE} transitions after the falling edge of SCLK.

Read/write bus timings listed in [Table 21-7](#) are shown in [Figure 21-5](#), [Figure 21-6](#), and [Figure 21-7](#).

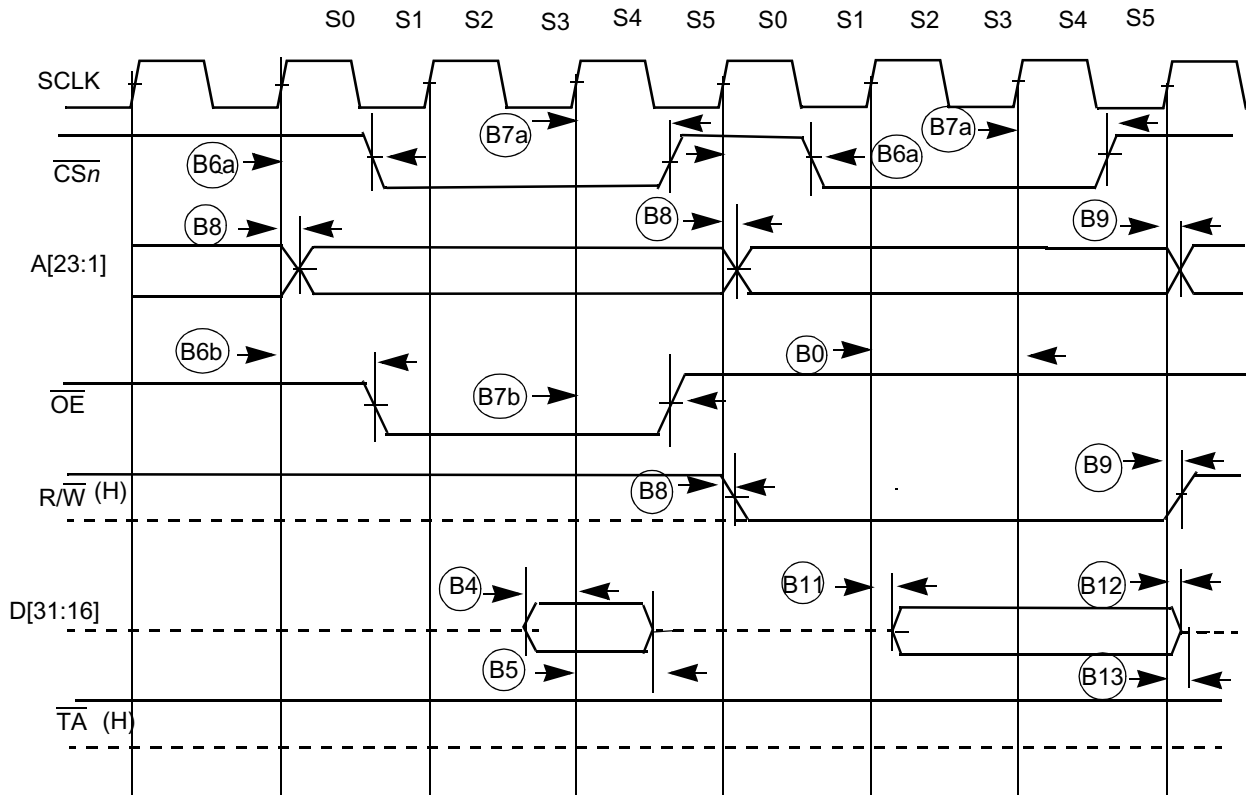

Figure 21-5 Read/Write (Internally Terminated) Timing

[Figure 21-6](#) shows a bus cycle terminated by \overline{TA} showing timings listed in [Table 21-7](#).

Freescale Semiconductor, Inc.

Supply Voltage Sequencing and Separation Cautions

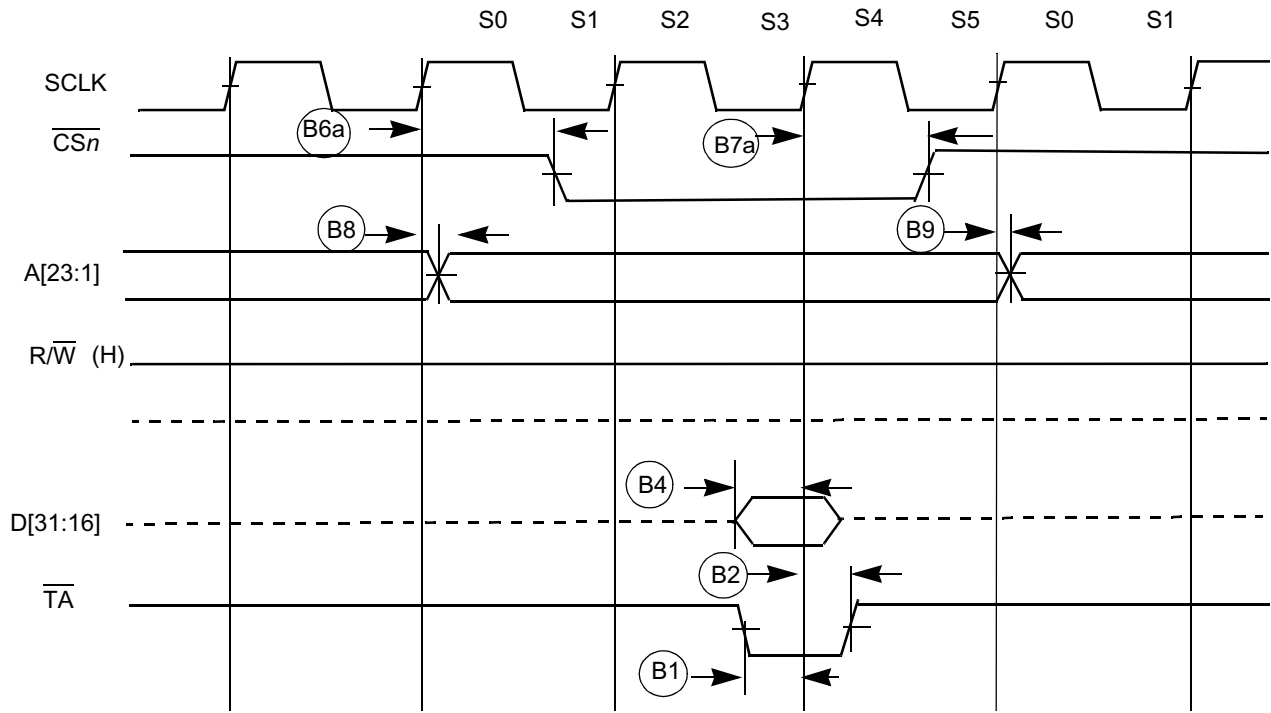

Figure 21-6 Read Bus Cycle Terminated by \overline{TA}

Figure 21-7 shows an SDRAM read cycle.

Table 21-8 SDRAM Timing

NUM	CHARACTERISTIC ^A	SYMBOL	MIN	MAX	UNIT
SD1	SCLK high to SDRAM address valid	t_{CHDAV}	—	10	ns
SD2	SCLK high to SDRAM control valid	t_{CHDCV}	—	11	ns
SD3	SCLK high to SDRAM address invalid	t_{CHDAI}	2	—	ns
SD4	SCLK high to SDRAM control invalid	t_{CHDCI}	2	—	ns
SD5	SDRAM data valid to SCLK high	t_{DDVCH}	6	—	ns
SD6	SCLK high to SDRAM data invalid	t_{CHDDI}	2	—	ns
SD7 ^b	SCLK high to SDRAM data valid	t_{CHDDVW}	—	10	ns
SD8 ²	SCLK high to SDRAM data invalid	t_{CHDDIW}	2	—	ns

- a. All timing specifications are based on taking into account, a 25pF load on the SDRAM output pins.
- b. D7 and D8 are for write cycles only.

Figure 21-7 shows an SDRAM write cycle.

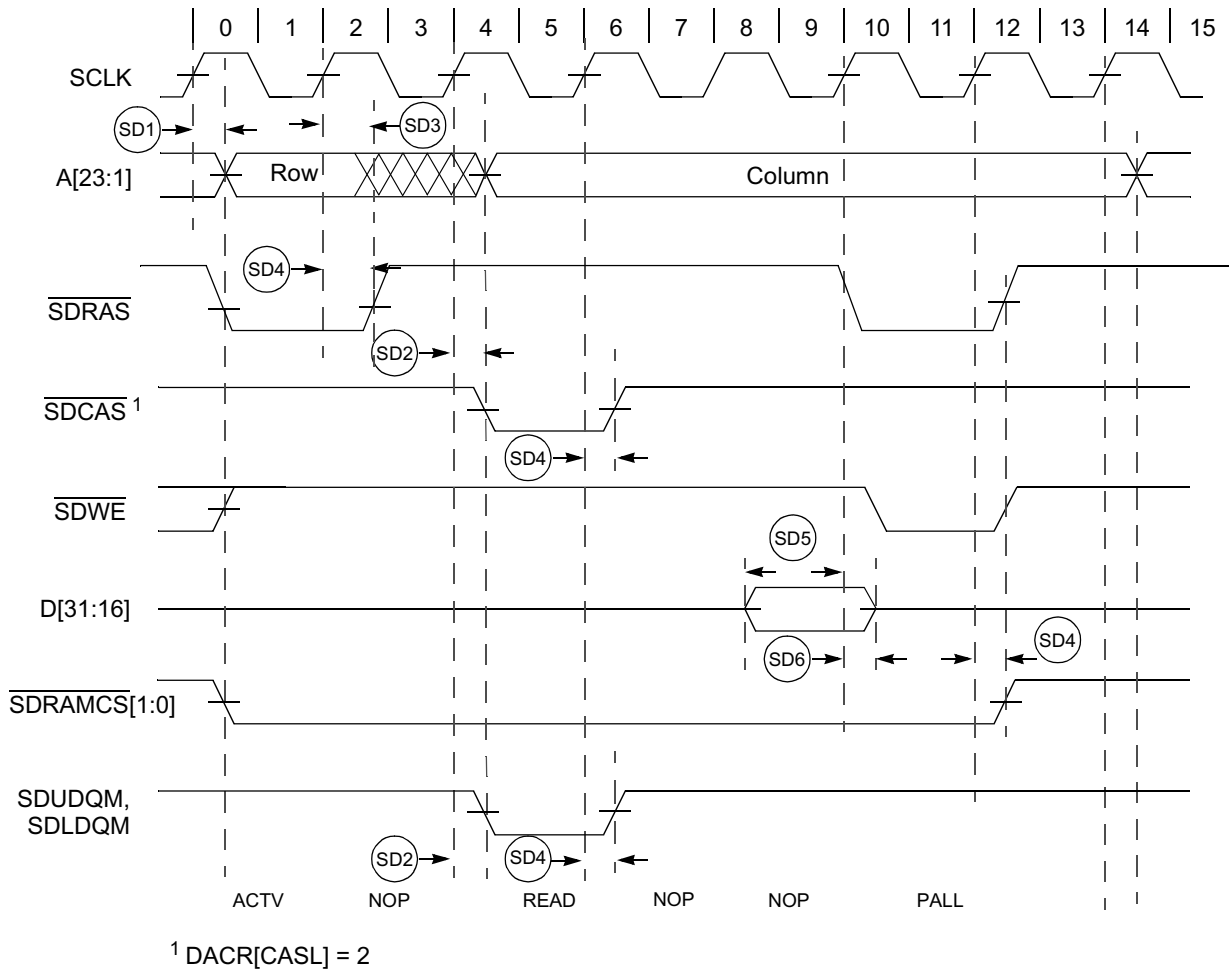

Figure 21-7 SDRAM Read Cycle

Figure 21-8 shows an SDRAM write cycle.

Freescale Semiconductor, Inc.

Supply Voltage Sequencing and Separation Cautions

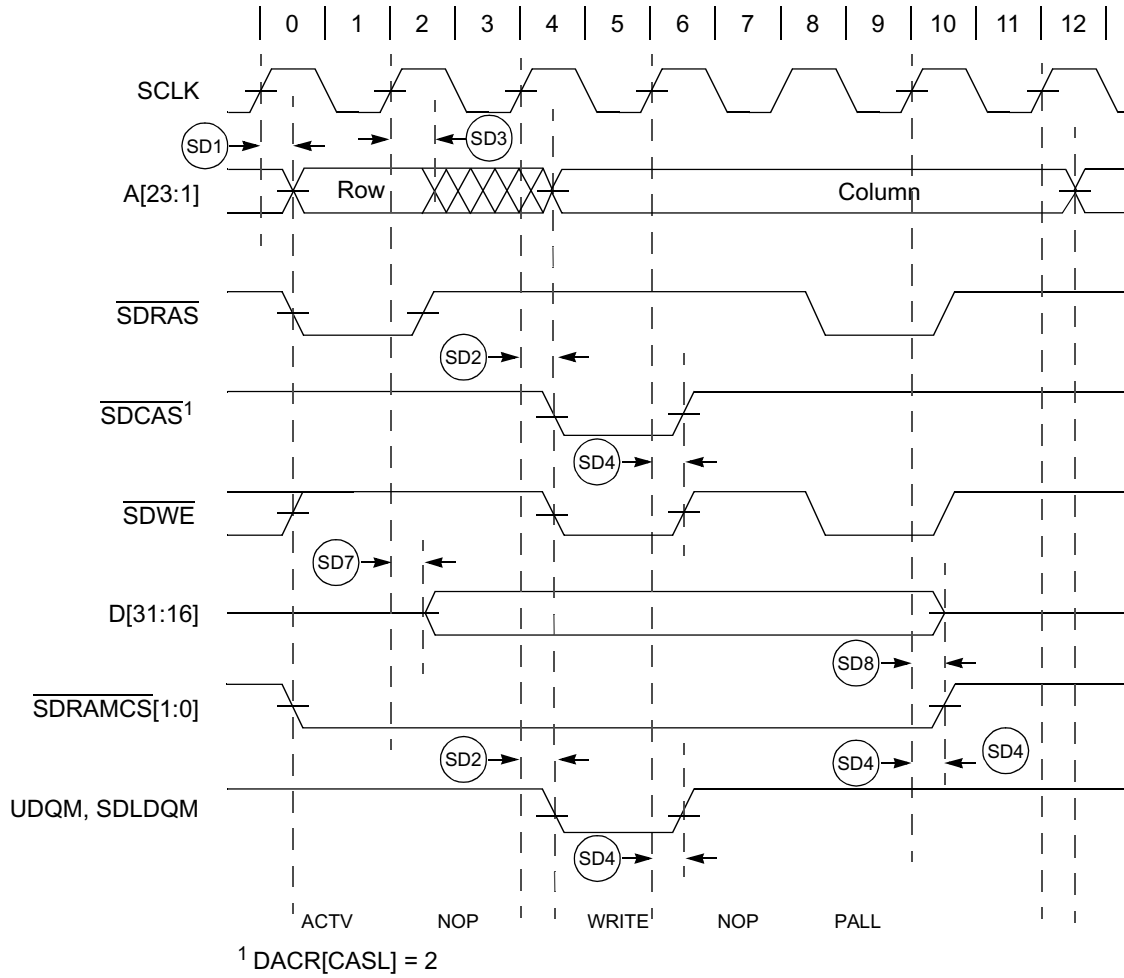

Figure 21-8 SDRAM Write Cycle

Table 21-9 Debug AC Timing Specification

NUM	CHARACTERISTIC			UNITS
		MIN	MAX	
D1	PSTCLK to signal Valid (Output valid)	---	6	nSec
D2	PSTCLK to signal Invalid (Output hold)	1.8	—	nSec
D3 ¹	Signal Valid to PSTCLK (Input setup)	3	—	nSec
D4	PSTCLK to signal Invalid (Input hold)	5	—	nSec

1. DSCLK and DSI are internally synchronized. This setup time must be met only if recognition on a particular clock is required.
2. AC timing specs assume 50pF load capacitance on PSTCLK and output pins. If this value is different, the input and output timing specifications would need to be adjusted to match the clock load.

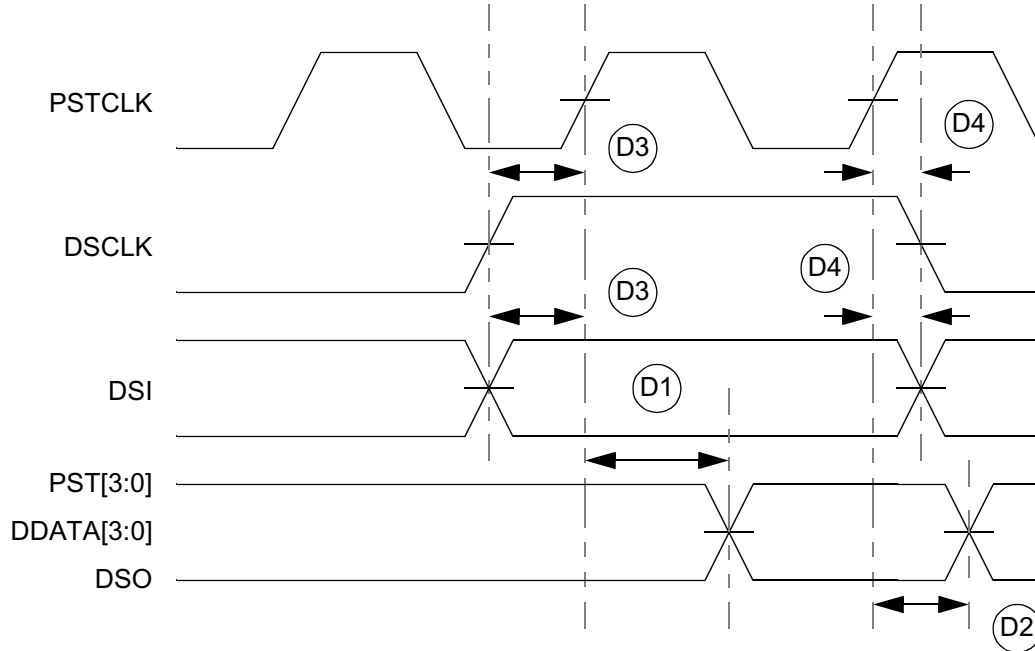

Figure 21-9 Debug Timing Definition

Table 21-10 Timer Module AC Timing Specification

NUM	CHARACTERISTIC			UNITS
		MIN	MAX	
T1	TIN Cycle time	tbd	—	bus clocks
T2	TIN Valid to SCLK (input setup)	tbd	—	nSec
T3	SCLK to TIN Invalid (input hold)	tbd	—	nSec
T4	SCLK to TOUT Valid (output valid)	—	tbd	nSec
T5	SCLK to TOUT Invalid (output hold)	tbd	—	nSec
T6	TIN Pulse Width	tbd	—	bus clocks
T7	TOUT Pulse Width	tbd	—	bus clocks

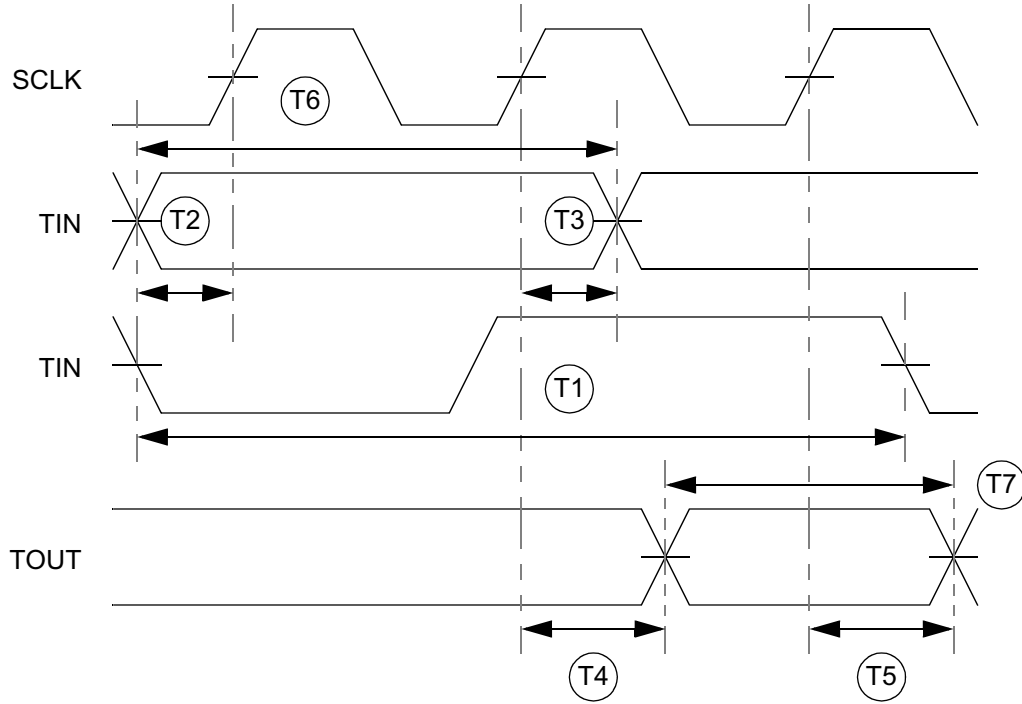

Figure 21-10 Timer Module Timing Definition

Table 21-11 UART Module AC Timing Specifications

NUM	CHARACTERISTIC			UNITS
		MIN	MAX	
U1	RXD Valid to SCLK (input setup)	tbd	—	nSec
U2	SCLK to RXD Invalid (input hold)	tbd	—	nSec
U3	$\overline{\text{CTS}}$ Valid to SCLK (input setup)	tbd	—	nSec
U4	SCLK to $\overline{\text{CTS}}$ Invalid (input hold)	tbd	—	nSec
U5	SCLK to TXD Valid (output valid)	---	tbd	nSec
U6	SCLK to TXD Invalid (output hold)	tbd	—	nSec
U7	SCLK to $\overline{\text{RTS}}$ Valid (output valid)	---	tbd	nSec
U8	SCLK to $\overline{\text{RTS}}$ Invalid (output hold)	tbd	—	nSec

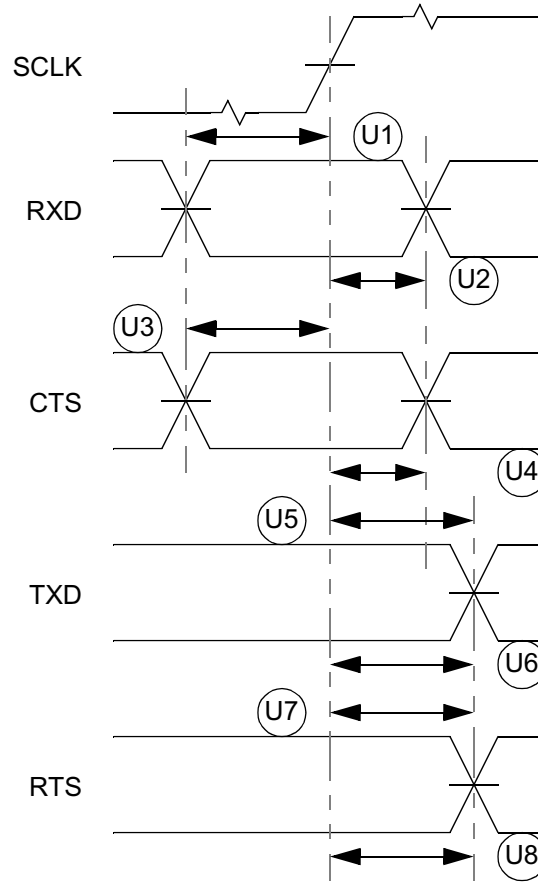

Figure 21-11 UART Timing Definition

Table 21-12 I²C-Bus Input Timing Specifications Between SCL and SDA

NUM	CHARACTERISTIC			UNITS
		MIN	MAX	
M1	Start Condition Hold Time	tbd	—	bus clocks
M2	Clock Low Period	tbd	—	bus clocks
M3	SCL/SDA Rise Time (VIL= 0.5 V to VIH = 2.4 V)	—	tbd	mSec
M4	Data Hold Time	tbd	—	nSec
M5	SCL/SDA Fall Time (VIH= 2.4 V to VIL = 0.5 V)	—	tbd	mSec
M6	Clock High time	tbd	—	bus clocks
M7	Data Setup Time	tbd	—	nSec
M8	Start Condition Setup Time (for repeated start condition only)	tbd	—	bus clocks
M9	Stop Condition Setup Time	tbd	—	bus clocks

Table 21-13 I²C-Bus Output Timing Specifications Between SCL and SDA

NUM	CHARACTERISTIC			UNITS
		MIN	MAX	
M1 ¹	Start Condition Hold Time	tbd	—	bus clocks
M2 ¹	Clock Low Period	tbd	—	bus clocks
M3 ²	SCL/SDA Rise Time (V _{IL} = 0.5 V to V _{IH} = 2.4 V)	—	tbd	mSec
M4 ¹	Data Hold Time	tbd	—	bus clocks
M5 ³	SCL/SDA Fall Time (V _{IH} = 2.4 V to V _{IL} = 0.5 V)	—	tbd	nSec
M6 ¹	Clock High time	tbd	—	bus clocks
M7 ¹	Data Setup Time	tbd	—	bus clocks
M8 ¹	Start Condition Setup Time (for repeated start condition only)	tbd	—	bus clocks
M9 ¹	Stop Condition Setup Time	tbd	—	bus clocks

- Note: Output numbers are dependent on the value programmed into the MFDR; an MFDR programmed with the maximum frequency (MFDR = 0x20) will result in minimum output timings as shown in the above table. The MBUS interface is designed to scale the actual data transition time to move it to the middle of the SCL low period. The actual position is affected by the prescale and division values programmed into the MFDR; however, numbers given in the above table are the minimum values.
- Since SCL and SDA are open-collector-type outputs, which the processor can only actively drive low, the time required for SCL or SDA to reach a high level depends on external signal capacitance and pull-up resistor values.
- Specified at a nominal 20 pF load

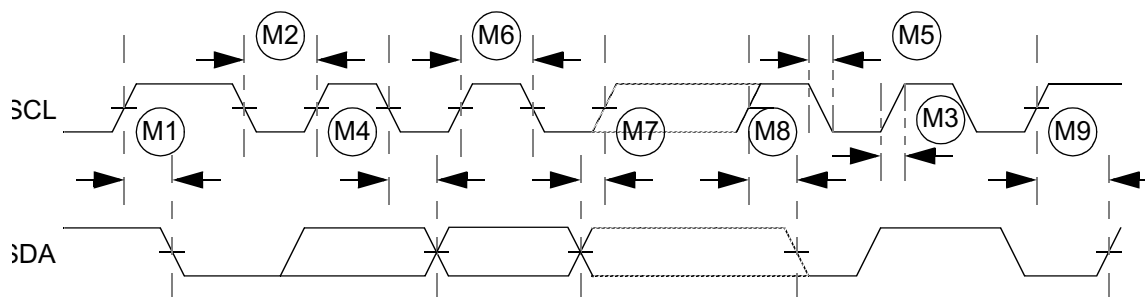

Figure 21-12 I²C Timing Definition

Table 21-14

NUM	CHARACTERISTIC			UNITS
		MIN	MAX	
M10 ³	SCL, SDA Valid to SCLK (input setup)	tbd	—	nSec
M11	SCLK to SCL, SDA Invalid (input hold)	tbd	—	nSec
M12 ¹	SCLK to SCL, SDA Low (output valid)	—	tbd	nSec
M13 ²	SCLK to SCL, SDA Invalid (output hold)	tbd	—	nSec

1. Since SCL and SDA are open-collector-type outputs, which the processor can only actively drive low, this specification applies only when SCL or SDA are driven low by the processor. The time required for SCL or SDA to reach a high level depends on external signal capacitance and pull-up resistor values.
2. Since SCL and SDA are open-collector-type outputs, which the processor can only actively drive low, this specification applies only when SCL or SDA are actively being driven or held low by the processor.
3. SCL and SDA are internally synchronized. This setup time must be met only if recognition on a particular clock is required.

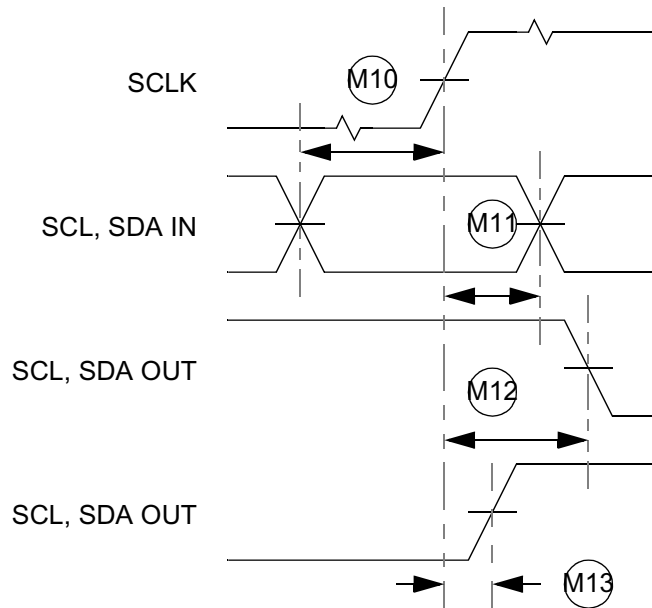

Figure 21-13 I²C and System Clock Timing Relationship

Table 21-15 General-Purpose I/O Port AC Timing Specifications

NUM	CHARACTERISTIC			UNITS
		MIN	MAX	
P1	GPIO Valid to SCLK (input setup)	tbd	—	nSec
P2	SCLK to GPIO Invalid (input hold)	tbd	—	nSec
P3	SCLK to GPIO Valid (output valid)	—	tbd	nSec
P4	SCLK to GPIO Invalid (output hold)	tbd	—	nSec

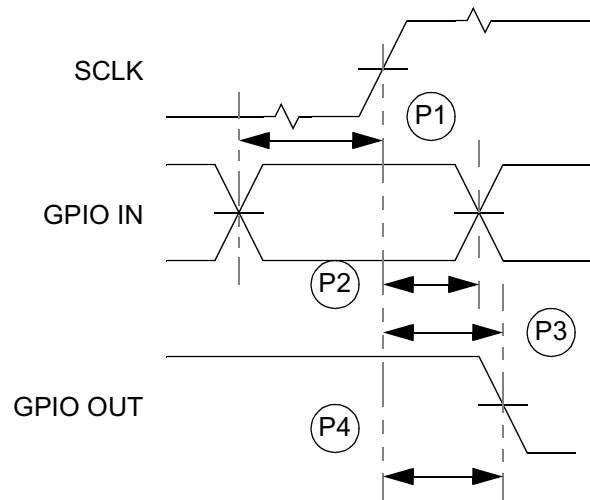

Figure 21-14 General-Purpose Parallel Port Timing Definition

Table 21-16 IEEE 1149.1 (JTAG) AC Timing Specifications

NUM	CHARACTERISTIC			UNITS
		MIN	MAX	
-	TCK Frequency of Operation	0	10	MHz
J1	TCK Cycle Time	100	-	nSec
J2a	TCK Clock Pulse High Width	25	-	nSec
J2b	TCK Clock Pulse Low Width	25	-	nSec
J3a	TCK Fall Time ($V_{IH}=2.4\text{ V}$ to $V_{IL}=0.5\text{V}$)	—	5	nSec
J3b	TCK Rise Time ($V_{IL}=0.5\text{v}$ to $V_{IH}=2.4\text{V}$)	—	5	nSec
J4	TDI, TMS to TCK rising (Input Setup)	8	—	nSec
J5	TCK rising to TDI, TMS Invalid (Hold)	10	—	nSec
J6	Boundary Scan Data Valid to TCK (Setup)	tbd	—	nSec
J7	TCK to Boundary Scan Data Invalid to rising edge (Hold)	tbd	—	nSec
J8	$\overline{\text{TRST}}$ Pulse Width (asynchronous to clock edges)	12	—	nSec
J9	TCK falling to TDO Valid (signal from driven or three-state)	—	15	nSec
J10	TCK falling to TDO High Impedance	—	15	nSec
J11	TCK falling to Boundary Scan Data Valid (signal from driven or three-state)	—	tbd	nSec
J12	TCK falling to Boundary Scan Data High Impedance	—	tbd	nSec

Freescale Semiconductor, Inc.
 Supply Voltage Sequencing and Separation Cautions

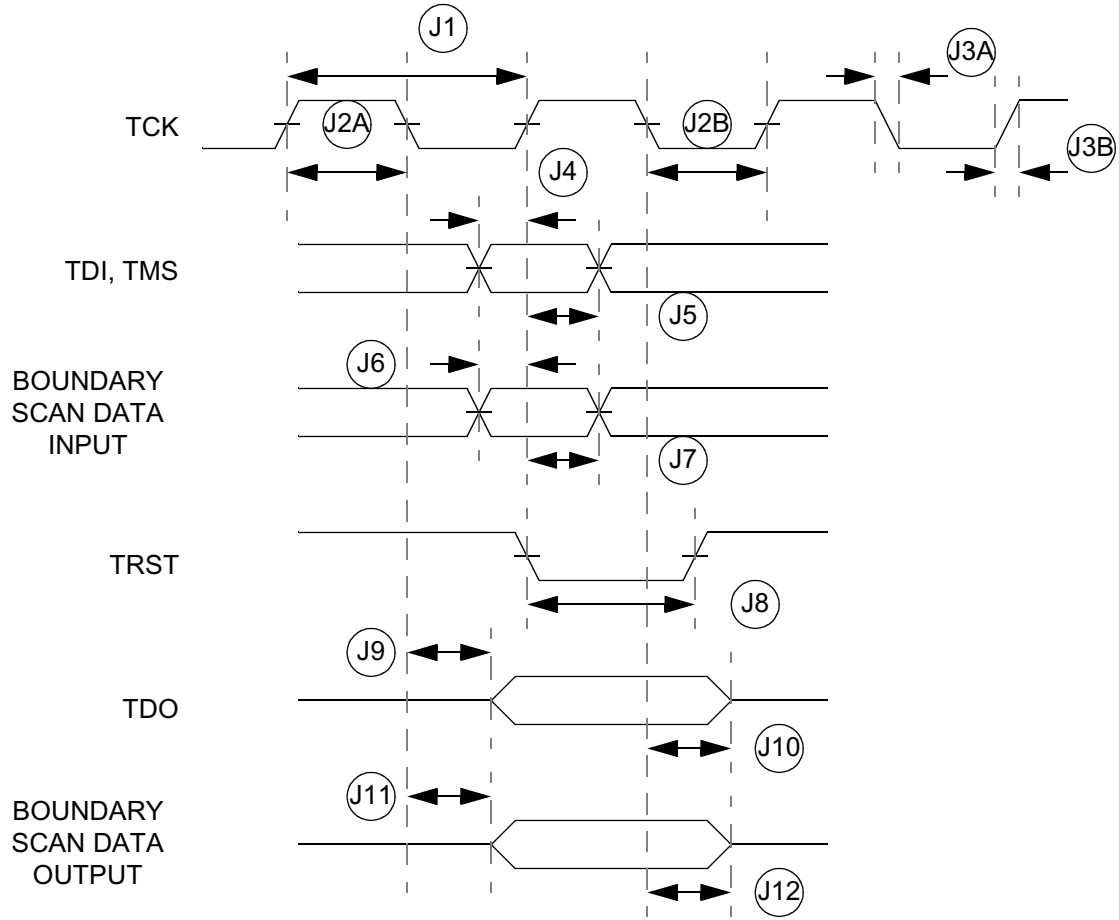

Figure 21-15

21.2 JTAG TIMING DEFINITION IIS MODULE AC TIMING SPECIFICATIONS

Table 21-17 SCLK INPUT, SDATAO OUTPUT Timing Specifications

NAME	CHARACTERISTIC			UNIT
		MIN	MAX	
TU	SCLK fall to SDATAO rise	---	25	ns
TD	SCLK fall to SDATAO fall	---	25	ns

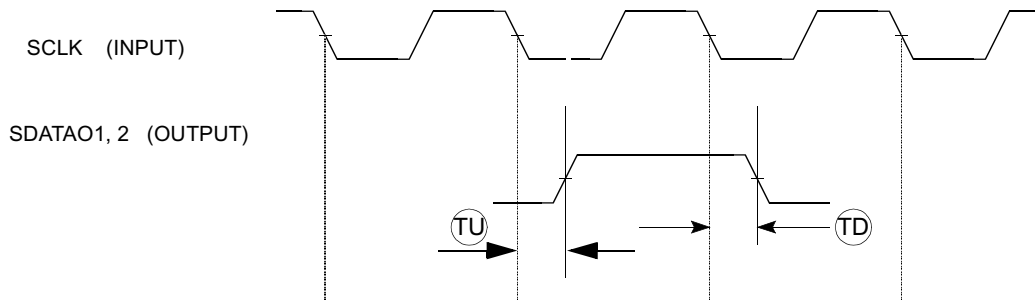

Figure 21-16 SCLK Input, SDATA Output Timing

Table 21-18 SCLK OUTPUT, SDATA0 OUTPUT Timing Specifications

NAME	CHARACTERISTIC			UNIT
		MIN	MAX	
TU	SCLK fall to SDATAO rise	---	3	ns
TD	SCLK fall to SDATAO fall	---	3	ns

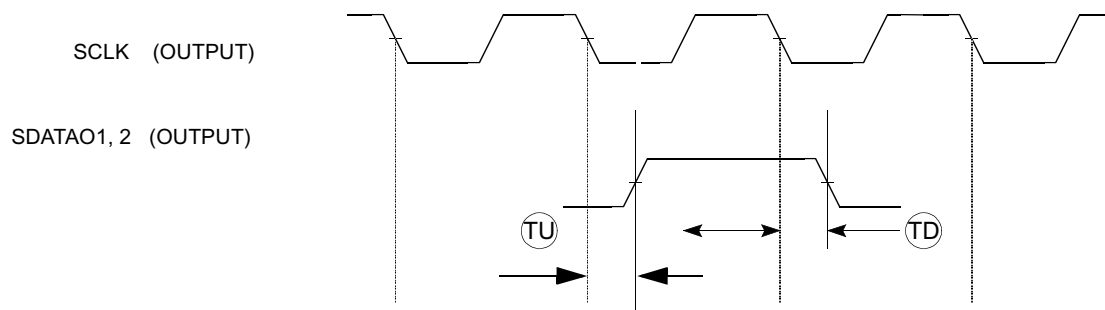

Figure 21-17 SCLK Output, SDATAO Output Timing Diagram

Table 21-19 SCLK INPUT, SDATAI INPUT Timing Specifications

NAME	CHARACTERISTIC			UNIT
		MIN	MAX	
TSU	SDATAI IN to SCLKn	-5	—	ns
TH	SCLK rise to SDATAI	3	—	ns

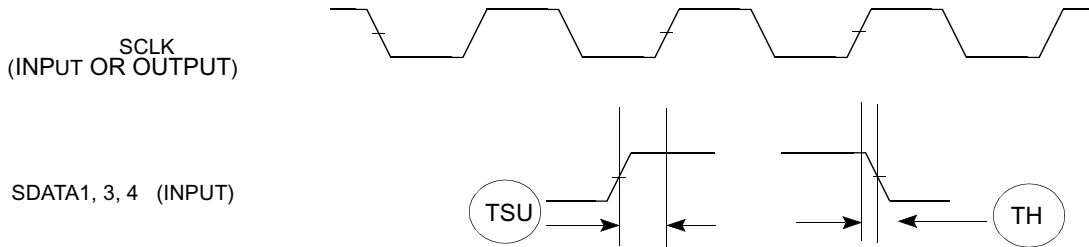

Figure 21-18 SCLK Input/Output, SDATAI Input Timing Diagram

Section 22

Mechanical Data

Visit the URL [<http://www.motorola.com/coldfire>] and choose the documentation library to obtain information on the mechanical characteristics of the MCF5249 integrated microprocessor.

22.1 PACKAGE

The MCF5249 can be assembled in either a 160-pin MAP BGA or 144-pin QFP package. Thermal characteristics are not available at this time.

22.2 PIN ASSIGNMENT

The MCF5249 is available in 160 pin MAPBGA package and 144 pin QFP package options.

Table 22-1 144 QFP Pin Assignments

144 QFP PIN NUMBER	NAME	TYPE	DESCRIPTION
1	SCL/QSPI_CLK	i/o	IIC clock/QSPI clock pin function select is PLLCR(11)
2	CS0	o	static chip select 0
3	A21	o	SDRAM address / static adr
4	A11	o	SDRAM address / static adr
5	A10	o	SDRAM address / static adr
6	A9	o	SDRAM address / static adr
7	A18	o	SDRAM address / static adr
8	A17	o	SDRAM address / static adr
9	BCLK/GPIO10	i/o	sdram clock output
10	SCLK_OUT/GPIO15	i/o	MemoryStick/SD
11	BCLKE	o	sdram clock enable output
12	SDA/QSPI_DIN	i/o	IIC data/QSPI data in function select is PLLCR(11)
13	DATA24	i/o	data
14	A22	o	SDRAM address / static adr
15	SDUDQM	o	SDRAM UDQM
16	EF/GPIO19	i/o	error flag input
17	DATA25	i/o	data
18	DATA26	i/o	data
19	DATA27	i/o	data
20	PAD-GND		PAD-GND
21	DATA28	i/o	data
22	DATA29	i/o	data
23	SDATA3/GPIO56	i/o	SD interface data line
24	DATA30	i/o	data
25	BUFENB1/GPIO57	i/o	external buffer 1 enable
26	DATA31	i/o	data
27	CORE-VDD		CORE-VDD
28	A13	o	SDRAM address / static adr
29	CORE-GND		CORE-GND
30	A23	o	SDRAM address / static adr
31	A14	o	SDRAM address / static adr
32	A15	o	SDRAM address / static adr
33	A16	o	SDRAM address / static adr
34	PAD-VDD		PAD-VDD
35	A19	o	SDRAM address / static adr
36	A20	o	SDRAM address / static adr
37	TEST2	i	test

Table 22-1 144 QFP Pin Assignments

144 QFP PIN NUMBER	NAME	TYPE	DESCRIPTION
38	SDRAM_CS1	o	SDRAM chip select out 1
39	SDATA1_BS1/GPIO9	i/o	Memory Stick / SD
40	SDRAS	o	SDRAM RAS
41	SDCAS	o	SDRAM CAS
42	SDWE	o	SDRAM write enable
43	SDLQDM	o	SDRAM LDQM
44	GPIO5	i/o	GPIO5
45	QSPI_CS0/GPIO29	i/o	QSPI chip select 0
46	QSPI_DOUT/GPIO26	i/o	QSPI data out
47	GPIO6	i/o	GPIO6
48	DATA21	i/o	data
49	DATA19	i/o	data
50	QSPI_CS2/GPIO21	i/o	QSPI chip select 2
51	DATA20	i/o	data
52	DATA22	i/o	data
53	DATA18	i/o	data
54	DATA23	i/o	data
55	DATA17	i/o	data
56	PAD-VDD		PAD-VDD
57	DATA16	i/o	data
58	CFLG/GPIO18	i/o	CFLG input
59	EBUOUT1/GPO36	o	audio interfaces EBU out 1
60	CORE-GND		CORE-GND
61	EBUIN3/ADIN0/GPI38	i	audio interfaces EBU in 3 / AD convertor input0
62	EBUIN2/GPI37	i	audio interfaces EBU in 2
63	CORE-VDD		CORE-VDD
64	SCL2/GPIO3	i/o	IIS2 clock line
65	RSTI	i	Reset
66	TOUT1/ADOUT/GPO35	o	timer output 1 / AD output
67	LRCK2/GPIO44	o	audio interfaces EBU out 1
68	OE	o	Output Enable
69	SDA2/GPIO55	i/o	IIS2 data
70	SDATAO2/GPO41	o	audio interfaces serial data output 2
71	SCLK2/GPIO48	i/o	audio interfaces serial clock 2
72	PAD-GND		PAD-GND
73	TEST3	i	test
74	SDATAO1/GPIO25	i/o	audio interfaces serial data output 1
75	LRCK1	i/o	audio interfaces word clock 1
76	LRCK4/GPIO46	i/o	audio interfaces word clock 4

Table 22-1 144 QFP Pin Assignments

144 QFP PIN NUMBER	NAME	TYPE	DESCRIPTION
77	SDATAI4/GPI42	i	audio interfaces serial data in 4
78	SCLK1	i/o	audio interfaces serial clock 1
79	SCLK4/GPIO50	i/o	audio interfaces serial clock 4
80	TA/GPIO20	i/o	Transfer acknowledge
81	SDATAI1	i	audio interfaces serial data in 1
82	EBUIN1/GPI36	i	audio interfaces EBU in 1
83	PLLGRDVDD		PLLGRDVDD
84	PLLGRDGND		PLLGRDGND
85	PLLPADGND		PLLPADGND
86	PLLPADVDD		PLLPADVDD
87	PLLCOREGND		PLLCOREGND
88	PLLCOREVDD		PLLCOREVDD
89	IDE-DIOW/GPIO14	i/o	ide diow
90	CRIN	i	crystal
91	IDE-DIOR/GPIO13	i/o	ide dior
92	IDE-IORDY/GPIO16	i/o	ide iordy
93	MCLK1/GPO39	o	Audio master clock output 1
94	MCLK2/GPO42	o	Audio master clock output 2
95	XTRIM/GPO38	o	audio interfaces X-tal trim
96	TRST/DSCLK	i	JTAG/Debug
97	CORE-VDD		CORE-VDD
98	RW_B	o	Bus write enable
99	TMS/BKPT	i	JTAG/debug
100	CORE-GND		CORE-GND
101	TCK	i	JTAG
102	PAD-GND		PAD-GND
103	PST3/GPIO62	i/o	debug
104	CNPSTCLK/GPO63	o	debug
105	PST1/GPIO60	i/o	debug
106	PAD-VDD		PAD-VDD
107	PST2/GPIO61	i/o	debug
108	PST0/GPIO59	i/o	debug
109	TDI/DSI	i	jtag/debug
110	TEST0	i	test
111	TIN0/GPI33	i	timer input 0
112	HI-Z	i	jtag
113	DDATA3/GPIO4	i/o	debug
114	TOUT0/GPO33	o	timer output 0
115	DDATA1/GPIO1	i/o	debug

Table 22-1 144 QFP Pin Assignments

144 QFP PIN NUMBER	NAME	TYPE	DESCRIPTION
116	DDATA2/GPIO2	i/o	debug
117	CTS2_B/ADIN3/GPI31	i	second UART clear to send / AD input 3
118	DDATA0/GPIO0	i/o	debug
119	RXD2/GPI28/ADIN2	i	second UART receive data input / AD input 2
120	TDSO	o	JTAG/debug
121	RTS2_B/GPO31	o	second UART request to send
122	SDATAI3/GPI41	i	audio interfaces serial data input 3
123	CTS1_B/GPI30	i	first UART clear to send
124	TXD2/GPO28	o	second UART transmit data output
125	RTS1_B/GPO30	o	first UART request to send
126	EBUIN4/ADIN1/GPI39	i	audio interfaces EBU input 4 / AD input 1
127	TXD1/GPO27	o	first UART transmit data output
128	RXD1/GPI27	i	first UART receive data input
129	CS1/GPIO58	i/o	chip select 1
130	CORE-GND		CORE-GND
131	A1	o	SDRAM address / static adr
132	TIN1/GPIO23	i/o	Timer input 1
133	A2	o	address
134	A3	o	address
135	PAD-GND		PAD-GND
136	A4	o	address
137	A6	o	address
138	A5	o	address
139	A8	o	address
140	A7	o	address
141	CORE-VDD		CORE-VDD
142	A12	o	address
143	TEST1	i	test
144	PAD-VDD		PAD-VDD

Freescale Semiconductor, Inc.

Pin Assignment

The following pins are in the 160 pin MAPBGA package, but are not available in the 144 pin QFP package.

Table 22-2 160 MAPBGA Pins

160 MAPBGA BALL NUMBER	FUNCTION	GPIO
E3	CMD_SDIO2	GPIO34
G4	SDATA0_SDIO1	GPIO54
H3	RSTO/SDATA2_BS2	
K3	A25	GPO8
L4	QSPI_CS1	GPIO24
L8	QSPI_CS3	GPIO22
N8	SDRAM_CS2	GPIO7
P9	EBUOUT2	GPO 37
K11	BUFENB2	GPIO17
G12	SUBR	GPIO 53
F13	SFSY	GPIO 52
F12	RCK	GPIO 51
E8	SRE	GPIO11
B8	LRCK3	GPIO 45
E7	SWE	GPIO12
A7	SCLK3	GPIO 49

Table 22-3 160 MAPBGA Pin Assignments

PIN BGA	NAME	TYP E	DESCRIPTION
D4	SCL/QSPI_CLK	i/o	IIC clock/QSPI clock pin function select is PLLCR(11)
A1	CS0	o	static chip select 0
D3	A21	o	SDRAM address / static adr
B1	A11	o	SDRAM address / static adr
C2	A10	o	SDRAM address / static adr
C1	A9	o	SDRAM address / static adr
E3	CMD_SDIO2/GPIO34	io	MemoryStick/SD
D2	A18	o	SDRAM address / static adr
D1	A17	o	SDRAM address / static adr
E2	BCLK/GPIO10	i/o	sdram clock output
F3	SCLK_OUT/GPIO15	i/o	MemoryStick/SD
E1	BCLKE	o	sdram clock enable output
E4	SDA/QSPI_DIN	i/o	IIC data/QSPI data in function select is PLLCR(11)
F2	DATA24	i/o	data bus bit 24
G3	A22	o	SDRAM address / static adr
F1	SDUDQM	o	SDRAM UDQM
F4	EF/GPIO19	io	Error flag input
G4	SDATA0_SDIO1/GPIO54	i/o	MemoryStick/SD
G1	DATA25	i/o	data bus bit 25
G2	DATA26	i/o	data bus bit 26
H3	RSTO/SDATA2_BS2	i/o	reset output/MemoryStick/SD/
H1	DATA27	i/o	data bus bit 27
H4	PAD-GND		PAD-GND
H4	PAD-GND		PAD-GND
H2	DATA28	i/o	data bus bit 28
J1	DATA29	i/o	data bus bit 29
J3	SDATA3/GPIO56	io	SD interface data line
J2	DATA30	i/o	data bus bit 30
J4	BUFENB1/GPIO57	io	external buffer 1 enable
K1	DATA31	i/o	data bus bit 31
K6	CORE-VDD		CORE-VDD
K6	CORE-VDD		CORE-VDD
K2	A13	o	SDRAM address / static adr
K3	A25/GPO8	o	SDRAM address / static adr
K5	CORE-GND		CORE-GND
K5	CORE-GND		CORE-GND
K4	A23	o	SDRAM address / static adr
L1	A14	o	SDRAM address / static adr

Table 22-3 160 MAPBGA Pin Assignments

PIN BGA	NAME	TYP E	DESCRIPTION
L2	A15	o	SDRAM address / static adr
M1	A16	o	SDRAM address / static adr
L3	PAD-VDD		PAD-VDD
L3	PAD-VDD		PAD-VDD
M2	A19	o	SDRAM address / static adr
N1	A20	o	SDRAM address / static adr
L4	QSPI_CS1/GPIO24	io	QSPI select 1
M3	TEST2	i	Structural test
N2	SDRAM_CS1	o	SDRAM chip select out 1
M4	SDATA1_BS1/GPIO9	i/o	MemoryStick/SD
P1	SDRAS	o	SDRAM RAS
P2	SDCAS	o	SDRAM CAS
N3	SDWE	o	SDRAM write enable
P3	SDLQDM	o	SDRAM LDQM
N4	GPIO5	i/o	general purpose i/o
P4	QSPI_CS0/GPIO29	i/o	QSPI chip select 0
N5	QSPI_DOUT/GPIO26	i/o	Qspi data out
L5	GPIO6	i/o	general purpose i/o
P5	DATA21	i/o	data bus bit 21
N6	DATA19	i/o	data bus bit 19
L6	QSPI_CS2/GPIO21	i/o	QSPI chip select 2
P6	DATA20	i/o	data bus bit 20
L7	DATA22	i/o	data bus bit 22
P7	DATA18	i/o	data bus bit 18
K7	DATA23	i/o	data bus bit 23
N7	DATA17	i/o	data bus bit 17
L8	QSPI_CS3/GPIO22	io	QSPI Chip Select 3
K8	PAD-VDD		PAD-VDD
K8	PAD-VDD		PAD-VDD
P8	DATA16	i/o	data bus bit 16
N8	SDRAM_CS2 / GPIO7	i/o	SDRAM chip select out 2 gpo
P9	EBUOUT2 / GPO 37	o	audio interfaces EBU out 2
L9	CFLG/GPIO18	io	CFLG input
N9	EBUOUT1 / GPO 36	o	audio interfaces EBU out 1
K9	CORE-GND		CORE-GND
K9	CORE-GND		CORE-GND
P10	EBUIN3 / ADIN0/GPI 38	i	audio interfaces EBU in 3 A/D convertor input 0
N10	EBUIN2 / GPI 37	i	audio interfaces EBU in 2

Table 22-3 160 MAPBGA Pin Assignments

PIN BGA	NAME	TYP E	DESCRIPTION
L10	CORE-VDD		CORE-VDD
L10	CORE-VDD		CORE-VDD
P11	SCL2/GPIO3	i/o	IIC clock
P12	RSTI	i	reset input
N11	TOUT1 / ADOUT/GPO35	o	timer output 1/ad output
P13	LRCK2 / GPIO 44	io	audio interfaces serial word clock 2
N12	OE	o	Output Enable
M11	SDA2/GPIO55	i/o	IIC 2 data line
P14	SDATAO2 / GPO41	o	audio interfaces serial data 2 out
N13	SCLK2 / GPIO 48	io	audio interfaces serial clock 2
K10	PAD-GND		PAD-GND
K10	PAD-GND		PAD-GND
K11	BUFENB2/GPIO17	io	external buffer 2 enable
M12	TEST3	i	Structural test
L12	SDATAO1/GPIO25	io	audio interfaces serial data 1 out
N14	LRCK1	io	audio interfaces serial word clock 1
M13	LRCK4 / GPIO 46	io	audio interfaces serial word clock 4
M14	SDATAI4 / GPI 42	i	audio interfaces serial data 4 in
L13	SCLK1	io	audio interfaces serial clock 1
L14	SCLK4 / GPIO 50	io	audio interfaces serial clock 4
L11	TA/GPIO20	i/o	Transfer Acknowledge
K13	SDATAI1	i	audio interfaces serial data 1 in
K12	EBUIN1 / GPI 36	i	audio interfaces EBU in 1
K14	PLLGRDVDD	io	PLL guard supply (1.8 V)
J11	PLLGRDGND		PLL guard supply GND
J13	PLLPADGND		3.3 Volt PLL GND
J12	PLLPADVDD		3.3 Volt PLL VDD
J14	PLLCOREGND		1.8 Volt PLL analog supply- GND
H11	PLLCOREVDD		1.8 Volt PLL analog supply - VDD
H12	IDE-DIOW/GPIO14	io	ide diow
H14	CRIN	i	crystal
H13	IDE-DIOR/GPIO13	io	IDE dior
G11	IDE-IORDY/GPIO16	i/o	ide iordy
G14	MCLK1/GPO39	o	Audio master clock output 1
G12	SUBR / GPIO 53	io	subcode data
G13	MCLK2/GPO42	o	Audio master clock output 2
F14	XTRIM/GPO 38	o	audio interfaces X-tal trim
F11	TRST/DSCLK	i	Jtag
F13	SFSY / GPIO 52	io	subcode sync

Table 22-3 160 MAPBGA Pin Assignments

PIN BGA	NAME	TYP E	DESCRIPTION
E9	CORE-VDD		CORE-VDD
E9	CORE-VDD		CORE-VDD
E14	RW_B	o	bus write enable
F12	RCK / GPIO 51	io	subcode clock
E13	TMS/BKPT	i	Jtag
E10	CORE-GND		CORE-GND
E10	CORE-GND		CORE-GND
E12	TCK	i	Jtag
E11	PAD-GND		PAD-GND
E11	PAD-GND		PAD-GND
D14	PST3/GPIO 62	io	coldFire debug port
D13	CNPSTCLK / GPO 63	o	coldfire debug clock
C14	PST1/GPIO 60	io	coldFire debug port
D12	PAD-VDD		PAD-VDD
D12	PAD-VDD		PAD-VDD
C13	PST2/GPIO 61	io	coldFire debug port
B14	PST0/GPIO 59	io	coldFire debug port
D11	TDI/DSI	i	Jtag
C12	TEST0	i	structural test
B13	TIN0 / GPI33	i	timer input 0
C11	HI-Z	i	Jtag
A14	DDATA3/GPIO 4	io	coldFire debug port
A13	TOUT0 / GPO33	o	timer output 0
B12	DDATA1/GPIO 1	io	coldFire debug port
A12	DDATA2/GPIO 2	io	coldFire debug port
B11	CTS2_B / ADIN3/GPI31	i	Second UART clear to send, AD input 3
A11	DDATA0/GPIO 0	io	coldFire debug port
B10	RXD2 / GPI28/ADIN2	i	Second UART receive data input AD input 2
D10	TDSO	o	Jtag
A10	RTS2_B / GPO31	o	Second UART request to send
B9	SDATAI3 / GPI 41	i	audio interfaces serial data 3 in
D9	CTS1_B / GPI30	i	First UART clear to send
A9	TXD2 / GPO28	o	Second UART transmit data output
D8	RTS1_B / GPO30	o	First UART request to send
A8	EBUIN4 / ADIN1/GPI 39	i	audio interfaces EBU in 4/ AD convertor input 1
E8	SRE/GPIO11	io	SmartMedia read enable
B8	LRCK3 / GPIO 45	io	audio interfaces serial word clock 3
E7	SWE/GPIO12	io	SmartMedia write enable

Table 22-3 160 MAPBGA Pin Assignments

PIN BGA	NAME	TYP E	DESCRIPTION
D7	TXD1 / GPO27	o	First UART transmit data output
A7	SCLK3 / GPIO 49	io	audio interfaces serial clock 3
B7	RXD1 / GPI27	i	First UART receive data input
A6	CS1 / GPIO58	io	static chip select 1 / gpio 1
E6	CORE-GND		CORE-GND
E6	CORE-GND		CORE-GND
B6	A1	o	static address A1
D6	TIN1/GPIO23	io	timer 1 in
A5	A2	o	Static address A2
B5	A3	o	Static address A3
D5	PAD-GND		PAD-GND
D5	PAD-GND		PAD-GND
A4	A4	o	static adr 4
A3	A6	o	static adr 6
B4	A5	o	static adr 5
A2	A8	o	static adr 8
B3	A7	o	static adr 7
C4	CORE-VDD		CORE-VDD
C4	CORE-VDD		CORE-VDD
B2	A12	o	SDRAM address / static adr
C3	TEST1	i	Structural test
E5	PAD-VDD		PAD-VDD
E5	PAD-VDD		PAD-VDD

 MOTOROLA Semiconductor Products Sector COPYRIGHT MOTOROLA, INC. ALL RIGHTS RESERVED <small>ELECTRONIC VERSIONS ARE UNCONTROLLED EXCEPT WHEN ACCESSED DIRECTLY FROM THE FINAL MANUFACTURING STRATEGIC OPERATIONS WEB PAGE IN PDF FORMAT. PRINTED VERSIONS ARE UNCONTROLLED.</small>	MECHANICAL OUTLINES DICTIONARY		DOCUMENT NO: 98ASS23177W	
			PAGE:	918
	DO NOT SCALE THIS DRAWING		ISSUE:	D

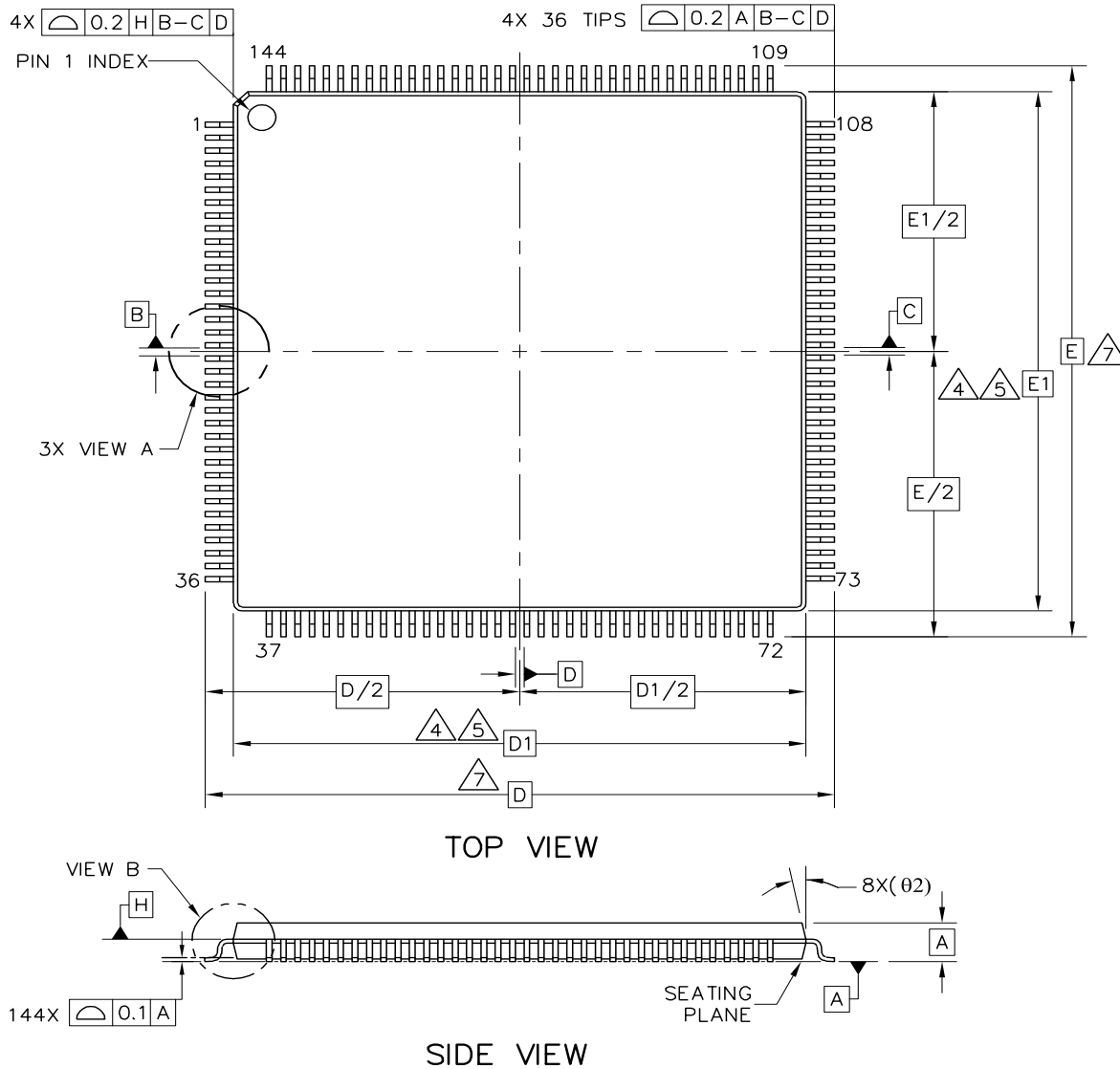

TITLE: 144 LEAD LQFP 20 X 20, 0.5 PITCH, 1.4 THICK	CASE NUMBER: 918-03	
	STANDARD: MOTOROLA	
	PACKAGE CODE: 8259	SHEET: 1 OF 3

Figure 22-1 144 QFP Package (1 of 3)

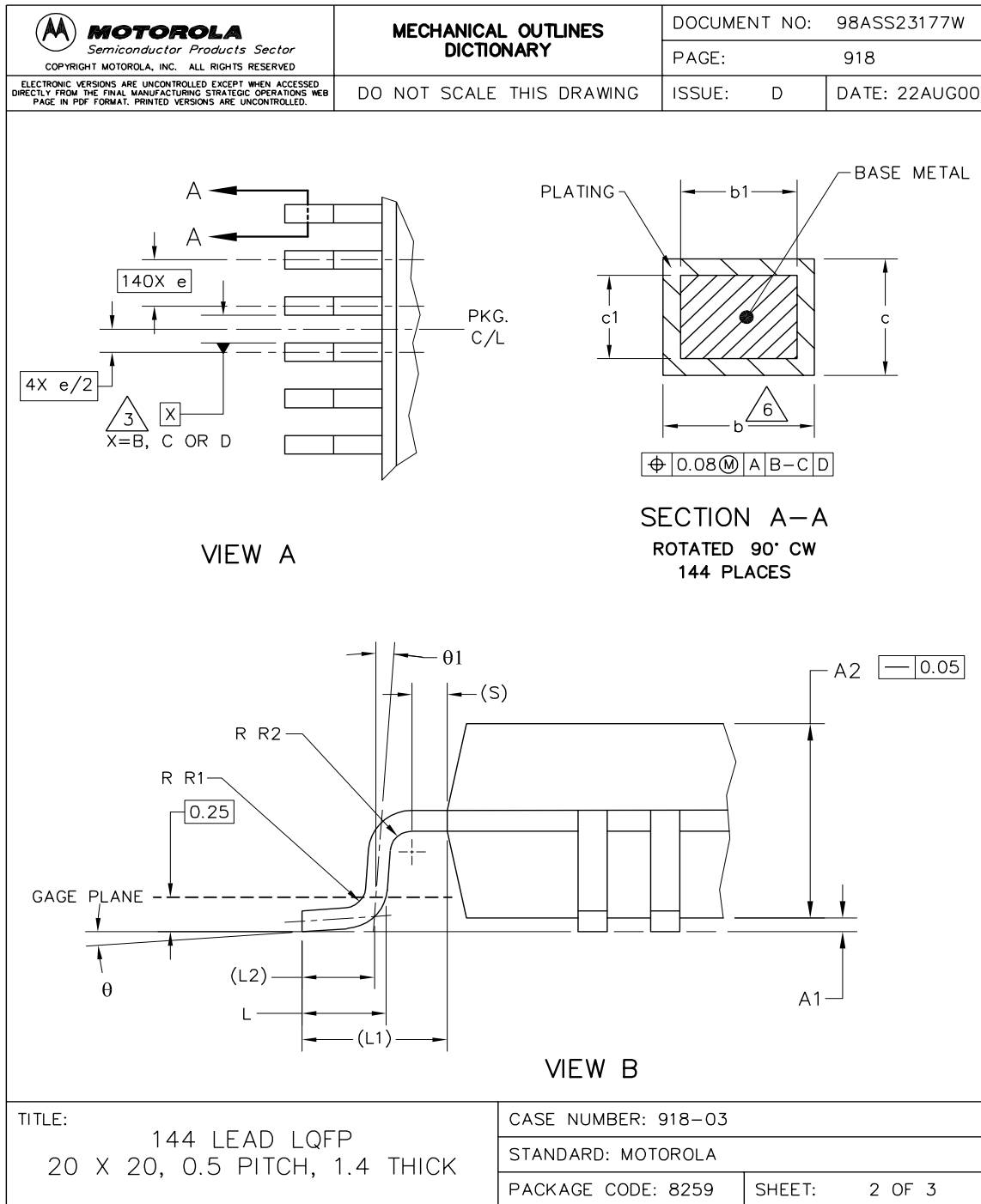

Figure 22-2 144 QFP Package (2 of 3)

Freescale Semiconductor, Inc.

Pin Assignment

 MOTOROLA Semiconductor Products Sector COPYRIGHT MOTOROLA, INC. ALL RIGHTS RESERVED			MECHANICAL OUTLINES DICTIONARY			DOCUMENT NO: 98ASS23177W			
<small>ELECTRONIC VERSIONS ARE UNCONTROLLED EXCEPT WHEN ACCESSED DIRECTLY FROM THE FINAL MANUFACTURING STRATEGIC OPERATIONS WEB PAGE IN PDF FORMAT. PRINTED VERSIONS ARE UNCONTROLLED.</small>			DO NOT SCALE THIS DRAWING			PAGE: 918			
						ISSUE: D		DATE: 22AUG00	
<p>NOTES:</p> <ol style="list-style-type: none"> 1. ALL DIMENSIONS ARE IN MILLIMETERS. 2. INTERPRET DIMENSIONS AND TOLERANCES PER ASME Y14.5M-1994. 3. DATUMS B, C AND D TO BE DETERMINED AT DATUM PLANE H. 4. THE TOP PACKAGE BODY SIZE MAY BE SMALLER THAN THE BOTTOM PACKAGE SIZE BY A MAXIMUM OF 0.1 mm. 5. DIMENSIONS D1 AND E1 DO NOT INCLUDE MOLD PROTRUSIONS. THE MAXIMUM ALLOWABLE PROTRUSION IS 0.25 mm PER SIDE. D1 AND E1 ARE MAXIMUM BODY SIZE DIMENSIONS INCLUDING MOLD MISMATCH. 6. DIMENSION b DOES NOT INCLUDE DAM BAR PROTRUSION. PROTRUSIONS SHALL NOT CAUSE THE LEAD WIDTH TO EXCEED 0.35. MINIMUM SPACE BETWEEN PROTRUSION AND AN ADJACENT LEAD SHALL BE 0.07 MM. 7. DIMENSIONS D AND E ARE DETERMINED AT THE SEATING PLANE, DATUM A. 									
DIM	MIN	MAX	DIM	MIN	MAX	DIM	MIN	MAX	
A	-	- 1.6	L1	- 1 REF	-	-	-	-	
A1	0.05	- 0.15	L2	- 0.5 REF	-	-	-	-	
A2	1.35	- 1.45	R1	0.13	- 0.2	-	-	-	
b	0.17	- 0.27	R2	0.13	-	-	-	-	
b1	0.17	- 0.23	S	- 0.25 REF	-	-	-	-	
c	0.09	- 0.20	θ	0°	- 7°	-	-	-	
c1	0.09	- 0.16	θ1	0°	-	-	-	-	
D	-	22 BSC	θ2	- 12° REF	-	-	-	-	
D1	-	20 BSC	-	-	-	-	-	-	
e	-	0.5 BSC	-	-	-	-	-	-	
E	-	22 BSC	-	-	-	-	-	-	
E1	-	20 BSC	-	-	-	-	-	-	
L	0.45	- 0.75	-	-	-	-	-	-	
TITLE: 144 LEAD LQFP 20 X 20, 0.5 PITCH, 1.4 THICK						CASE NUMBER: 918-03			
						STANDARD: MOTOROLA			
						PACKAGE CODE: 8259		SHEET: 3 OF 3	

Figure 22-3 144 QFP Package (3 of 3)

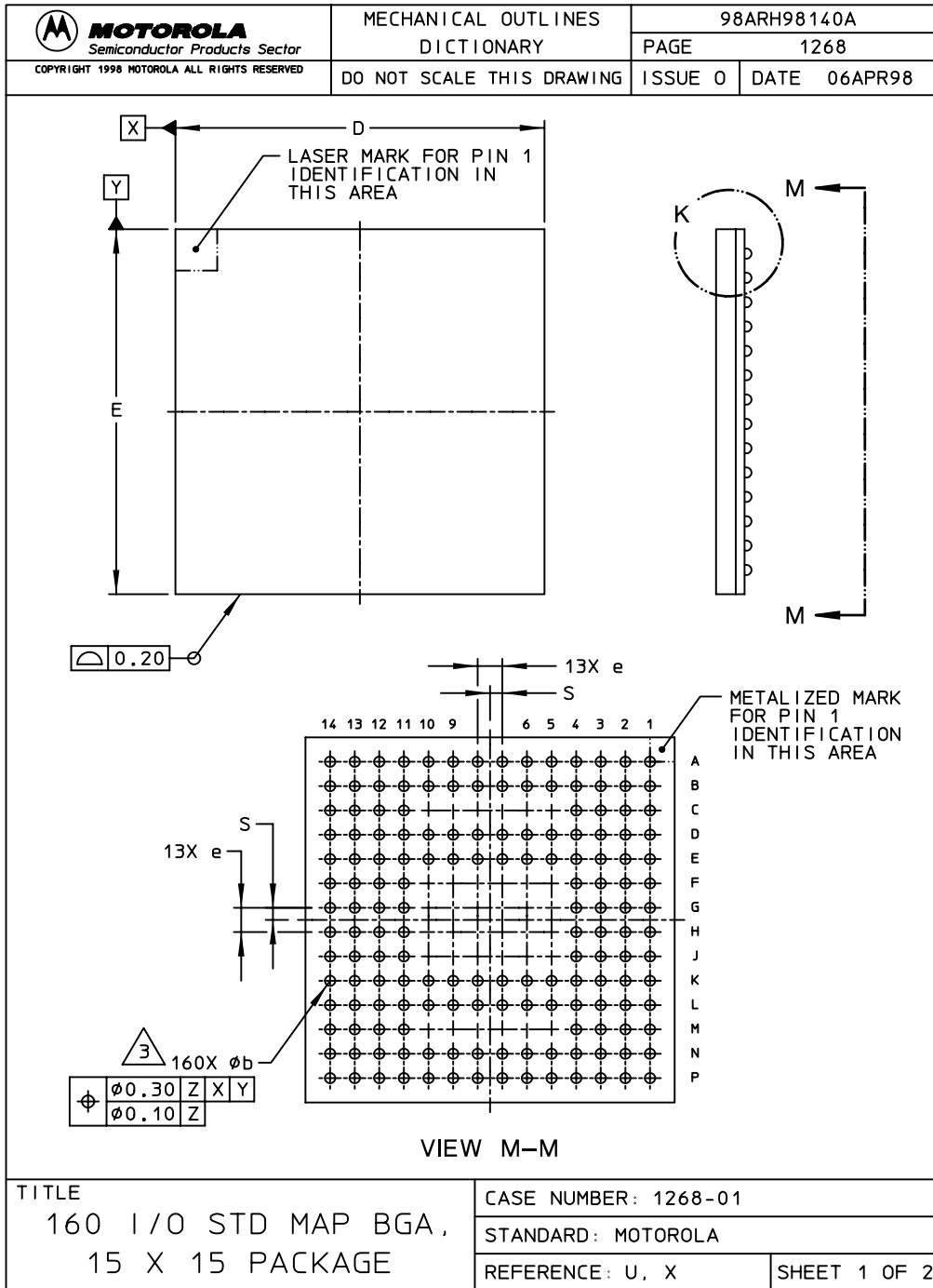

Figure 22-4 160 BGA Mechanical Package (1 of 2)

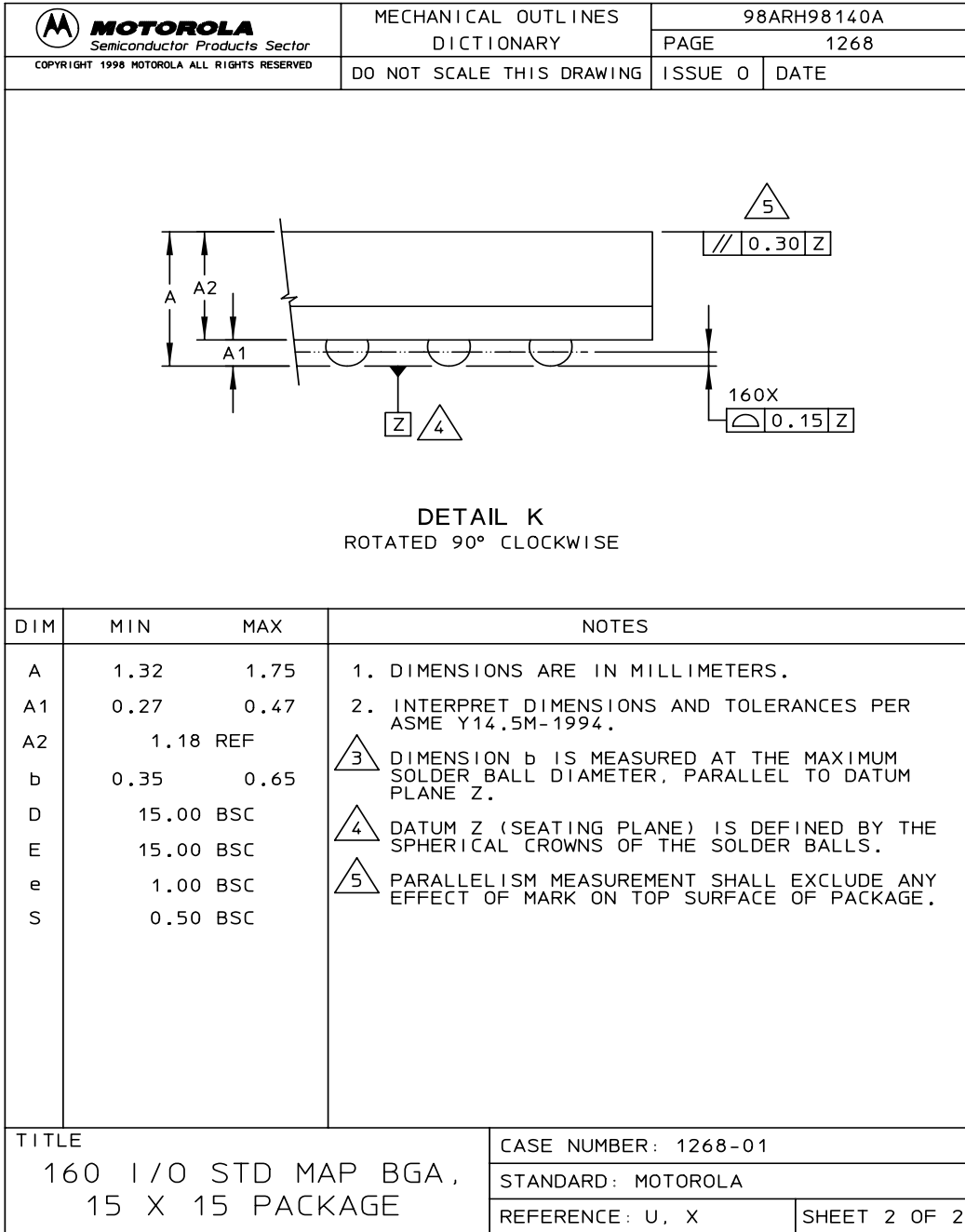

Figure 22-5 160 BGA Mechanical Package (2 of 2)

Appendix A

Register Memory Map

Table A-1 summarizes the address, name, and byte assignment for registers within the MCF5249.

Table A-1 CPU Memory Map

ADDRESS	NAME	SIZE (BYTES)	DESCRIPTION
CPU + \$002	CACR	4	Cache control register
CPU + \$004	ACR0	4	Access control reg 0
CPU + \$005	ACR1	4	Access control reg 1
CPU + \$801	VBR	4	Vector base address reg
CPU + \$C04	RAMBAR0	4	SRAM 0 configuration register
CPU + \$C05	RAMBAR1	4	SRAM 1 configuration register
CPU + \$C0F	MBAR	4	Module base address register1
CPU + \$C0E	MBAR2	4	Module base address register 2

Table A-2 MBAR Address Space Memory Map

ADDRESS	BYTE 0	BYTE 1	BYTE 2	BYTE 3	DESCRIPTION
MBAR + 000h	RSR	SYPCR	SWIVR	SWSR	System control reg
MBAR2 + 008h					PLL control reg
MBAR + 00Ch	MPARK				Bus master control reg
MBAR + 040h	IPR				Interrupt pending reg
MBAR + 044h	IMR				Interrupt mask register
MBAR + 04Ch	ICR0	ICR1	ICR2	ICR3	Interrupt control reg
MBAR + 050h	ICR4	ICR5	ICR6	ICR7	Interrupt control reg
MBAR + 054h	ICR8	ICR9	ICR10	ICR11	Interrupt control reg
MBAR + 080h	CSAR0				Chip select address reg 0
MBAR + 084h	CSMR0				Chip select mask reg 0
MBAR + 088h			CSCR0		Chip select control reg 0
MBAR + 08Ch	CSAR1				Chip select address reg 1
MBAR + 090h	CSMR1				Chip select mask reg 1
MBAR + 094h			CSCR1		Chip select control reg 1
MBAR + 098h	CSAR2				Chip select address reg 2
MBAR + 09Ch	CSMR2				Chip select mask reg 2
MBAR + 0A0h			CSCR2		Chip select control reg 2
MBAR + 0A4h	CSAR3				Chip select address reg 3
MBAR + 0A8h	CSMR3				Chip select mask reg 3
MBAR + 0ACh			CSCR3		Chip select control reg 3

Table A-2 MBAR Address Space Memory Map

ADDRESS	BYTE 0	BYTE 1	BYTE 2	BYTE 3	DESCRIPTION
MBAR + 100h	DCR				DRAMC control register
MBAR + 108h	DACR0				DRAMC addr and control 0
MBAR + 10Ch	DMR0				DRAMC mask reg 0
MBAR + 110h	DACR1				DRAMC addr and control1
MBAR + 114h	DMR1				DRAMC mask reg 1
MBAR + 140h	TMR0				Timer mode reg 0
MBAR + 144h	TRR0				Timer reference reg 0
MBAR + 148h	TCR0				Timer capture reg 0
MBAR + 14C	TCN0				Timer counter 0
MBAR + 150h		TER0			Timer event reg 0
MBAR + 180h	TMR1				Timer mode reg 1
MBAR + 184h	TRR1				Timer reference reg 1
MBAR + 188h	TCR1				Timer counter 1
MBAR + 18Ch	TCN1				
MBAR + 190h		TER1			Timer event reg 1
MBAR + 1C0h	UMR10/UMR20				UART mode reg 0
MBAR + 1C4h	USR0/UCSR0				UART status 0 UART clock select reg 10
MBAR + 1C8h	UCR0				UART command reg 0
MBAR + 1CCh	URB0/UTB0				UART receive 0 UART transmit buffer 0
MBAR + 1D0h	UIPCR0/UACR0				UART change 0 UART aux control reg 0
MBAR + 1D4h	UISR0/UIMR0				UART interrupt status 0 UART interrupt mask reg 0
MBAR + 1D8h	UBG10				UART baud rate generator MSB
MBAR + 1DCh	UBG20				UART baud rate generator LSB
MBAR + 1F0	UIVR0				UART interrupt vector reg 0
MBAR + 1F4h	UIP0				UART interrupt port 0
MBAR + 1F8h	UOP10				UART RTS Output Port 0
MBAR + 1FCh	UOP00				UART Output Port 0
MBAR + 200h	UMR11/UMR21				UART mode reg 1
MBAR + 204h	USR1/UCSR1				UART status 1 UART clock select reg 1
MBAR + 208h	UCR1				UART command reg 1
MBAR + 20Ch	URB1/UTB1				UART receive 1 UART transmit buffer 1
MBAR + 210h	UIPCR1/UACR1				UART change 1 UART aux control reg 1
MBAR + 214h	UISR1/UIMR1				UART interrupt status 1 UART interrupt mask reg 1
MBAR + 218h	UBG11				UART baud rate generator MSB

Table A-2 MBAR Address Space Memory Map

ADDRESS	BYTE 0	BYTE 1	BYTE 2	BYTE 3	DESCRIPTION
MBAR + 21Ch	UBG21				UART baud rate generator LSB
MBAR + 230	UIVR1				UART interrupt vector reg 1
MBAR + 234h	UIP1				UART interrupt port 1
MBAR + 238h	UOP11				UART RTS Output Port 1
MBAR + 23Ch	UOP01				UART Output Port 1
MBAR + 280h	MADR				Mbus address reg
MBAR + 284h	MFDR				Mbus frequency reg
MBAR + 288h	MBCR				Mbus control reg
MBAR + 28Ch	MBSR				Mbus status reg
MBAR + 290h	MBDR				Mbus data reg
MBAR + 300h	SAR0				DMA source address reg 0
MBAR + 304h	DAR0				DMA destination addr reg 0
MBAR + 308h	DCR0				DMA control reg 0
MBAR + 30Ch	BCR0				DMA byte count reg 0
MBAR + 310h	DSR0				DMA status reg 0
MBAR + 314h	DIVR0				DMA vector reg 0
MBAR + 340h	SAR1				DMA source address reg 1
MBAR + 344h	DAR1				DMA destination addr reg 1
MBAR + 348h	DCR1				DMA control reg 1
MBAR + 34Ch	BCR1				DMA byte count reg 1
MBAR + 350h	DSR1				DMA status reg 1
MBAR + 354h	DIVR1				DMA vector reg 1
MBAR + 380h	SAR2				DMA source address reg 2
MBAR + 384h	DAR2				DMA destination addr reg 2
MBAR + 388h	DCR2				DMA control reg 2
MBAR + 38Ch	BCR2				DMA byte count reg 2
MBAR + 390h	DSR2				DMA status reg 2
MBAR + 394h	DIVR2				DMA vector reg 2
MBAR + 3C0h	SAR3				DMA source address reg 3
MBAR + 3C4h	DAR3				DMA destination addr reg 3
MBAR + 3C8h	DCR3				DMA control reg 3
MBAR + 3CCh	BCR3				DMA byte count reg 3
MBAR + 3D0h	DSR3				DMA status reg 3
MBAR + 3D4h	DIVR3				DMA vector reg 3
MBAR + 400	QIR				QSPI mode register
MBAR + 404	QSPIQDLYR				QSPI delay register
MBAR + 408	QSPIQWR				QSPI Wrap register
MBAR + 40C	QSPIQIR				QSPI Interrupt register
MBAR + 410	QSPIQAR				QSPI address register

Table A-2 MBAR Address Space Memory Map

ADDRESS	BYTE 0	BYTE 1	BYTE 2	BYTE 3	DESCRIPTION
MBAR + 414	QIR				QSPI Data register
unlisted in range MBAR + 000 - 04FFh					Reserved, unpredictable don't use

Table A-3 Audio Interface Memory Map

ADDRESS	ACCESS	SIZE BITS	NAME	DESCRIPTION
MBAR2 + 0	R	32	GPIO-READ	Shows values of gpio 0-31 inputs
MBAR2 + 4	RW	32	GPIO-OUT	Values for gpio 0-31 outputs written to this register
MBAR2 + 8	RW	32	GPIO-ENABLE	Output enable register for gpios 0-31
MBAR2 + C	RW	32	GPIO-FUNCTION	Function selector for multi-purpose gpio 0-31 pins
MBAR2 + 10	RW	32	IIS1CONFIG	Config register for IIS interface 1
MBAR2 + 14	RW	32	IIS2CONFIG	Config register for IIS interface 2
MBAR2 + 18	RW	32	IIS3CONFIG	Config register for IIS interface 3
MBAR2 + 1C	RW	32	IIS4CONFIG	Config register for IIS interface 4
MBAR2 + 20	RW	32	EBU1CONFIG	Config register for EBU interface
MBAR2 + 24	R	32	EBU1RCVCCHANNEL1	Control channel as received by EBU1 interface - first 32 bits
MBAR2 + 28	RW	32	EBUTXCCHANNEL1	"C" channel bits for EBU transmitter - Consumer format
MBAR2 + 2C	RW	32	EBUTXCCHANNEL2	"C" channel bits for EBU transmitter - Professional format
MBAR2 + 30	RW	32	DATAINCONTROL	PDIR source select
MBAR2 + 34 MBAR2 + 38 MBAR2 + 3C MBAR2 + 40	R	32	PDIR1-L	Processor data in - Left Multiple read addresses allow MOVEM instruction to read fifo
MBAR2 + 44 MBAR2 + 48 MBAR2 + 4C MBAR2 + 50	R	32	PDIR3-L	Processor data in - Left Multiple read addresses allow MOVEM instruction to read fifo
MBAR2 + 54 MBAR2 + 58 MBAR2 + 5C MBAR2 + 60	R	32	PDIR1-R	Processor data in - Right
MBAR2 + 64 MBAR2 + 68 MBAR2 + 6C MBAR2 + 70	R	32	PDIR3-R	processor data in - Right

Table A-3 Audio Interface Memory Map

ADDRESS	ACCESS	SIZE BITS	NAME	DESCRIPTION
MBAR2 + 34 MBAR2 + 38 MBAR2 + 3C MBAR2 + 40	W	32	PDOR1-L	Processor data out 1 - Left
MBAR2 + 44 MBAR2 + 48 MBAR2 + 4C MBAR2 + 50	W	32	PDOR1-R	Processor data out 1 - Right
MBAR2 + 54 MBAR2 + 58 MBAR2 + 5C MBAR2 + 60	W	32	PDOR2-L	Processor data out 2 - Left
MBAR2 + 64 MBAR2 + 68 MBAR2 + 6C MBAR2 + 70	W	32	PDOR2-R	Processor data out 2 - Right
MBAR2 + 74 MBAR2 + 78 MBAR2 + 7C MBAR2 + 80	W	32	PDOR3	Processor data out 3 left + right
MBAR2 + 74 MBAR2 + 78 MBAR2 + 7C MBAR2 + 80	R	32	PDIR2	Processor data in 2 left + right
MBAR2 + 84	RW	32	UCHANNELTRANSMIT	U channel transmit register
MBAR2 + 88	R	32	U1CHANNELRECEIVE	U channel receive register, first ebu receiver
MBAR2 + 8C	R	32	Q1CHANNELRECEIVE	Q channel receive register, first ebu receiver
MBAR2 + 92	RW	8	CD TEXT CONTROL	CD text configuration register
MBAR2 + 94	RW	32	INTERRUPTEN	Interrupt enable register
MBAR2 + 98	W	32	INTERRUPTCLEAR	Clear interrupt register
MBAR2 + 98	R	32	INTERRUPTSTAT	Interrupt status register
MBAR2 + 9F	RW	8	DMACONFIG	Configure DMA
MBAR2 + A3	RW	8	PHASECONFIG	Configure phase measurement circuit
MBAR2 + A6	RW	16	XTRIM	Value output on XTRIM pin
MBAR2 + A8	R	32	FREQMEAS	Phase /Frequency measurement
MBAR2 + AF	RW	8	Reserved	Reserved
MBAR2 + CA	RW	16	blockControl	Block decoder / encoder control
MBAR2 + CE	RW	16	audioGlob	Audio block new features
MBAR2 + D0	RW	32	ebu2config	Config register for EBU2 interface
MBAR2 + D4	R	32	EBU2RCVCCHANNEL1	Control channel as received by EBU2 interface - first 32 bits

Table A-3 Audio Interface Memory Map

ADDRESS	ACCESS	SIZE BITS	NAME	DESCRIPTION
MBAR2 + D8	R	32	U2CHANNELRECEIVE	U channel receive register, second ebu receiver
MBAR2 + DC	R	32	Q2CHANNELRECEIVE	Q channel receive register, second ebu receiver

Table A-4 GPIO and Interrupt Status Memory Map

ADDRESS	ACCESS	SIZE BITS	NAME	DESCRIPTION
MBAR2 + B0	R	32	GPIO1-READ	Shows values of gpio 32-63 inputs
MBAR2 + B4	RW	32	GPIO1-OUT	Values for gpio 32-63 outputs written to this register
MBAR2 + B8	RW	32	GPIO1-ENABLE	Output enable register for gpio 32-63
MBAR2 + BC	RW	32	GPIO1-FUNCTION	Function selector for multi-purpose gpio 62-63 pins
MBAR2 + C0	R	32	GPIO-INT-STAT	Interrupt status 2
MBAR2 + C0	W	32	GPIO-INT-CLEAR	Interrupt clear 2
MBAR2 + C4	RW	32	GPIO-INT-EN	Interrupt enable 2
MBAR2 + E0	R	32	INTERRUPTSTAT3	Interrupt status 3
MBAR2 + E0	W	32	INTERRUPTCLEAR3	Interrupt clear 3
MBAR2 + E4	RW	32	INTERRUPTEN3	Interrupt enable 3
MBAR2 + 140	RW	32	INTPRI1	Interrupts 0-7 level
MBAR2 + 144	RW	32	INTPRI2	Interrupts 8-15 level
MBAR2 + 148	RW	32	INTPRI3	Interrupts 16-23 level
MBAR2 + 14C	RW	32	INTPRI4	Interrupts 24-31 level
MBAR2 + 150	RW	32	INTPRI5	Interrupts 32-39 level
MBAR2 + 154	RW	32	INTPRI6	Interrupts 40-47 level
MBAR2 + 158	RW	32	INTPRI7	Interrupts 48-55 level
MBAR2 + 15C	RW	32	INTPRI8	Interrupts 56-63 level
MBAR2 + 167	RW	8	SPURVEC	Spurious interrupt vector number
MBAR2 + 16B	RW	8	INTBASE	Interrupt base vector register
MBAR2 + 180	RW	32	PLLCONTROL	Register to program PLL frequency
MBAR2 + 188	RW	32	DMAROUTE	DMA source control
MBAR2 + 18C	RW	32	IDE CONFIG1	IDE interface configuration register
MBAR2 + 190	RW	32	IDE CONFIG2	IDE interface configuration register
MBAR2 + 194	R	32	IPERRORADR	Address of last error on IPbus
MBAR2 + 198	RW	32	EXTRAINT	Interrupt monitors and software interrupts
MBAR2 + 200	RW	32		QSPI interface?

Table A-5 A/D, MBUS2 and Memory Stick Memory Map

ADDRESS	ACCESS	SIZE BITS	NAME	DESCRIPTION
MBAR2 + 402h	RW	16	ADCONFIG	AD Configuration and Status Register
MBAR2 + 406h	R	16	ADVALUE	AD Measurement Result
MBAR2 + 408h - 43Ch				Reserved, unpredictable DON'T USE
MBAR2 + 440h	RW	8	MADR2	M-Bus 2 Address Register
MBAR2 + 444h	RW	8	MFDR2	M-Bus 2 Frequency Divider Register
MBAR2 + 448h	RW	8	MBCR2	M-Bus 2 Control Register
MBAR2 + 44Ch	RW	8	MBSR	M-Bus 2 Status Register
MBAR2 + 450h	RW	8	MBDR	M-Bus 2 Data I/O Register
MBAR2 + 460h	RW	32	FLASHMEDIACONFIG	Clock and General configuration
MBAR2 + 464h	RW	32	FLASHMEDIACMD1	Command register for Interface 1
MBAR2 + 468h	RW	32	FLASHMEDIACMD2	Command register for Interface 2
MBAR2 + 46Ch	RW	32	FLASHMEDIADATA1	Data register for Interface 1
MBAR2 + 470h	RW	32	FLASHMEDIADATA2	Data register for Interface 2
MBAR2 + 474h	RW	32	FLASHMEDIASTATUS	Status register
MBAR2 + 478h	RW	32	FLASHMEDIINTEN	Interrupt enable register
MBAR2 + 47Ch	R	32	FLASHMEDIINTSTAT	Interrupt status register
MBAR2 + 47Ch	W	32	FLASHMEDIINTCLEAR	Interrupt clear register

NOTES

Freescale Semiconductor, Inc.

Freescale Semiconductor, Inc.

**For More Information On This Product,
Go to: www.freescale.com**

Freescale Semiconductor, Inc.

HOW TO REACH US:

USA/EUROPE/LOCATIONS NOT LISTED:

Motorola Literature Distribution
P.O. Box 5405
Denver, Colorado 80217
1-800-521-6274 or 480-768-2130

JAPAN:

Motorola Japan Ltd.
SPS, Technical Information Center
3-20-1, Minami-Azabu, Minato-ku
Tokyo 106-8573, Japan
81-3-3440-3569

ASIA/PACIFIC:

Motorola Semiconductors H.K. Ltd.
Silicon Harbour Centre
2 Dai King Street
Tai Po Industrial Estate
Tai Po, N.T., Hong Kong
852-26668334

HOME PAGE:

<http://motorola.com/semiconductors>

Freescale Semiconductor, Inc.



Information in this document is provided solely to enable system and software implementers to use Motorola products. There are no express or implied copyright licenses granted hereunder to design or fabricate any integrated circuits or integrated circuits based on the information in this document.

Motorola reserves the right to make changes without further notice to any products herein. Motorola makes no warranty, representation or guarantee regarding the suitability of its products for any particular purpose, nor does Motorola assume any liability arising out of the application or use of any product or circuit, and specifically disclaims any and all liability, including without limitation consequential or incidental damages. "Typical" parameters that may be provided in Motorola data sheets and/or specifications can and do vary in different applications and actual performance may vary over time. All operating parameters, including "Typicals", must be validated for each customer application by customer's technical experts. Motorola does not convey any license under its patent rights nor the rights of others. Motorola products are not designed, intended, or authorized for use as components in systems intended for surgical implant into the body, or other applications intended to support or sustain life, or for any other application in which the failure of the Motorola product could create a situation where personal injury or death may occur. Should Buyer purchase or use Motorola products for any such unintended or unauthorized application, Buyer shall indemnify and hold Motorola and its officers, employees, subsidiaries, affiliates, and distributors harmless against all claims, costs, damages, and expenses, and reasonable attorney fees arising out of, directly or indirectly, any claim of personal injury or death associated with such unintended or unauthorized use, even if such claim alleges that Motorola was negligent regarding the design or manufacture of the part.

MOTOROLA and the Stylized M Logo are registered in the US Patent and Trademark Office. All other product or service names are the property of their respective owners. Motorola, Inc. is an Equal Opportunity/Affirmative Action Employer.

© Motorola Inc. 2003

MCF5249UM/D
Rev. 4
10/2003

**For More Information On This Product,
Go to: www.freescale.com**