

QT-Brightek PLCC2 Series

PLCC2 White LED

Part No.: QBLP670-IW5

5: 5mA

Table of Contents:

Introduction	3
Electrical / Optical Characteristic (Ta=25 °C)	4
Absolute Maximum Rating	4
Correlated Color Temperature Chart	5
Characteristic Curves.....	6
Solder Profile & Footprint.....	7
Packing	8
Labeling	9
Ordering Information	9
Disclaimer	10

Introduction

Feature:

- Package in tape and reel
- Ultra bright reflector type PLCC2 LED
- InGaN technology for White
- Yellow diffused lens
- Viewing angle: 120 deg typ.

Description:

These ultra bright reflector type PLCC2 LEDs have a height profile of 1.90mm. With a combination of high brightness output and robust package, these LEDs are ideal for architecture lighting, status indication, and industrial equipment lighting applications.

Application:

- Status indication
- Equipment backlighting
- Interior lighting
- Household equipment lighting

Certification & Compliance:

- ISO9001
- RoHS Compliant



Dimension:

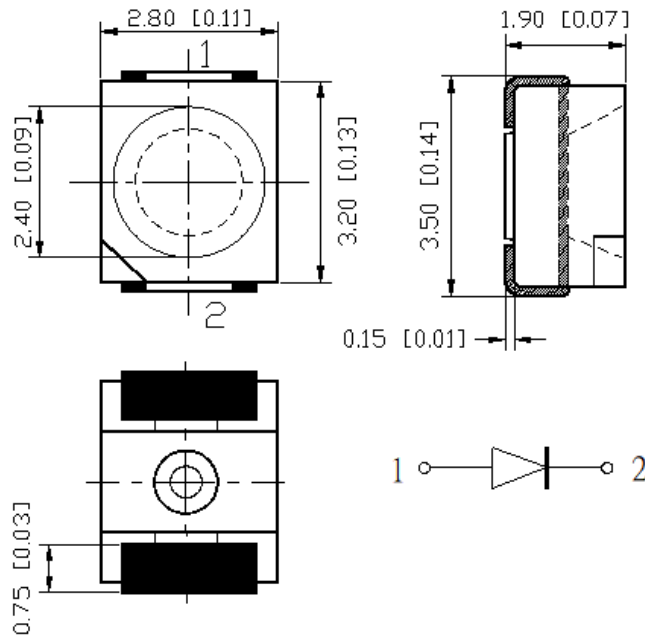

Units: mm / tolerance = +/-0.2mm

Electrical / Optical Characteristic (Ta=25 °C)

Product	Color	I _F (mA)	V _F (V)		CIE Coordinates	I _v (mcd)		
			Typ.	Max.	Typ.	Min.	Typ.	Max.
QBLP670-IW5	White	5	2.7	3.1	X=0.30, Y=0.287	320	580	1000

Absolute Maximum Rating

Material	P _d (mW)	I _F (mA)	I _{FP} (mA)*	V _R (V)	T _{OP} (°C)	T _{ST} (°C)	T _{SO L} (°C)**
InGaN	93	30	125	5	-40 to +80	-40 to +85	260

*Duty 1/8 @ 1KHz

**IR Reflow for no more than 10 sec @ 260 °C

Forward Voltage V_F @ I_F=5mA

Bin	Min.	Max.	Unit
A	2.5	2.7	V
B	2.7	2.9	
C	2.9	3.1	

Luminous Intensity I_v @ I_F=5mA

Bin	Min.	Max.	Unit
O	320	400	mcd
P	400	500	
Q	500	630	
R	630	800	
S	800	1000	

Correlated Color Temperature Chart

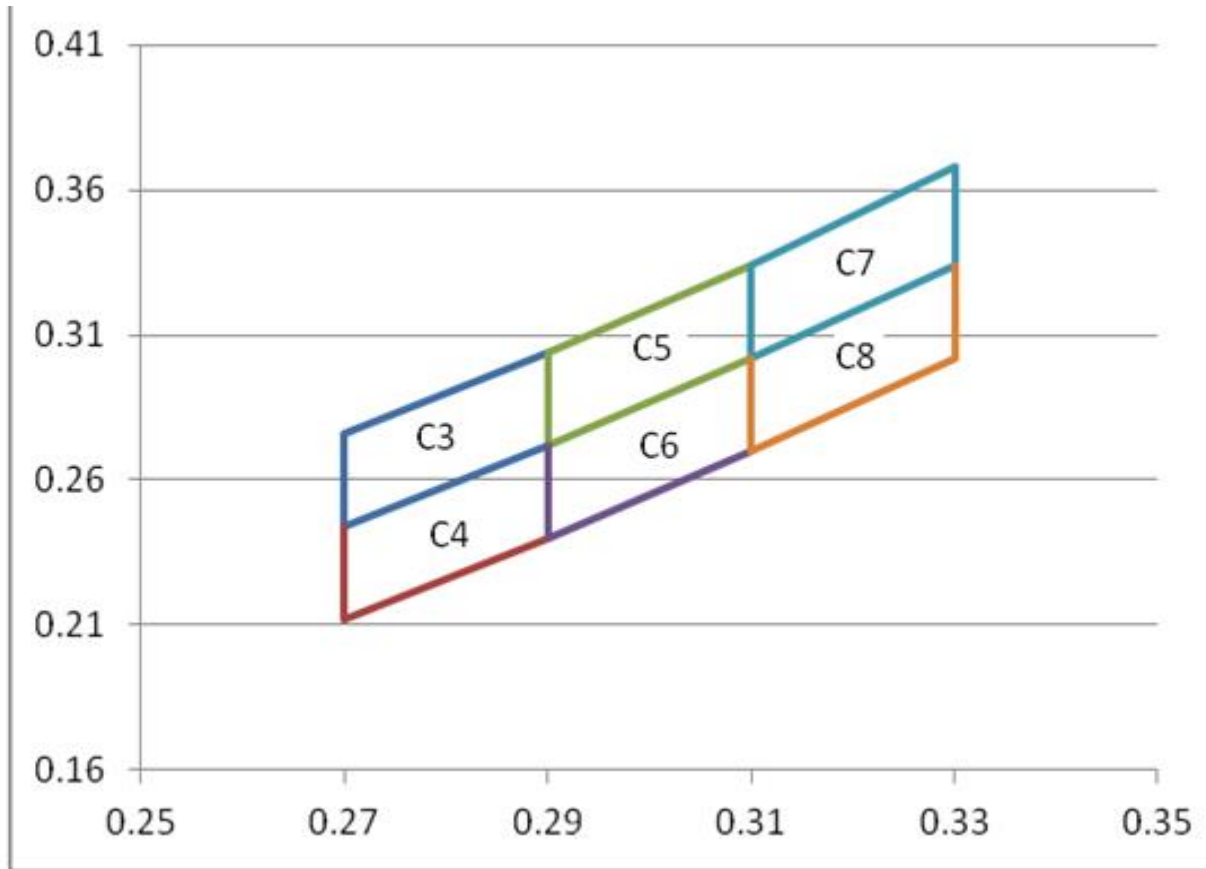

Rank	Chromaticity coordinates				
C3	X	0.27	0.27	0.29	0.29
	Y	0.276	0.244	0.272	0.304
C4	X	0.27	0.27	0.29	0.29
	Y	0.244	0.212	0.24	0.272
C5	X	0.29	0.29	0.31	0.31
	Y	0.304	0.272	0.302	0.334
C6	X	0.29	0.29	0.31	0.31
	Y	0.272	0.24	0.27	0.302
C7	X	0.31	0.31	0.33	0.33
	Y	0.334	0.302	0.334	0.368
C8	X	0.31	0.31	0.33	0.33
	Y	0.302	0.27	0.302	0.334

Characteristic Curves

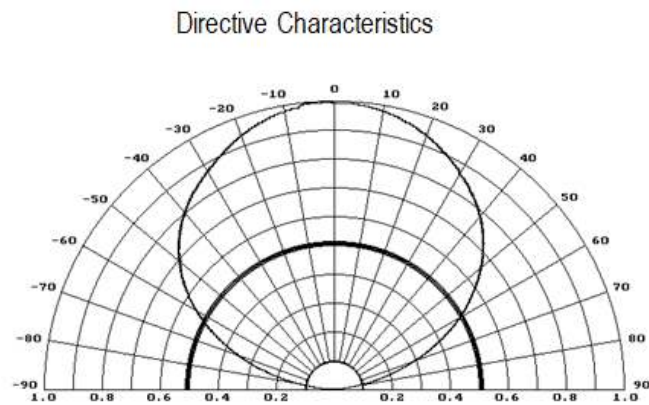
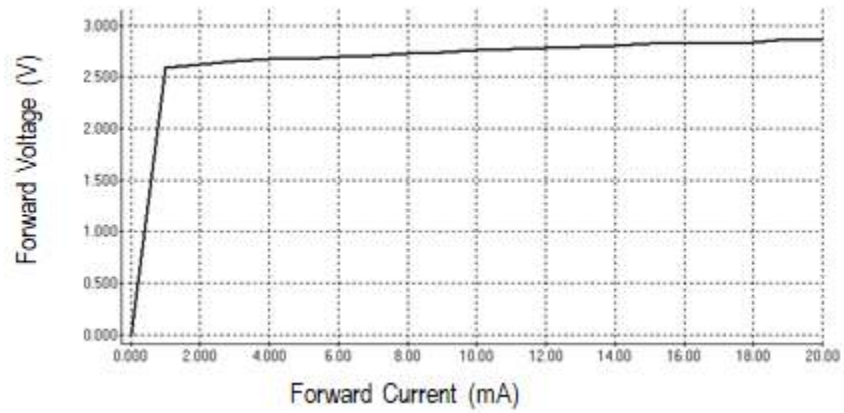
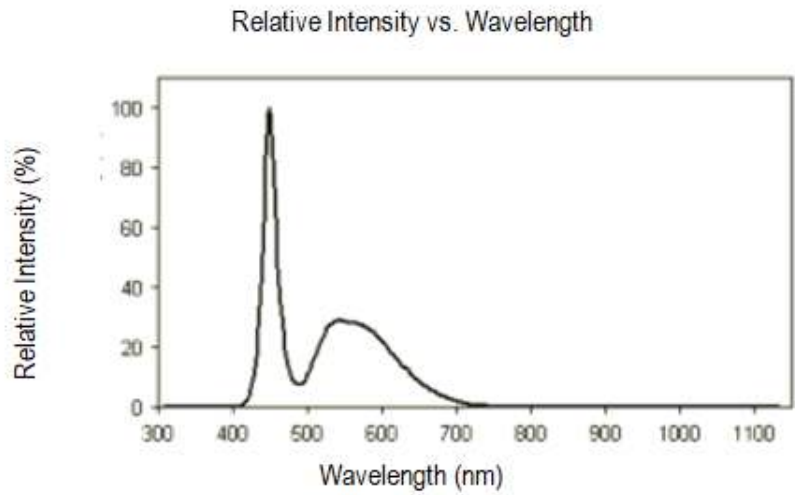

Solder Profile & Footprint

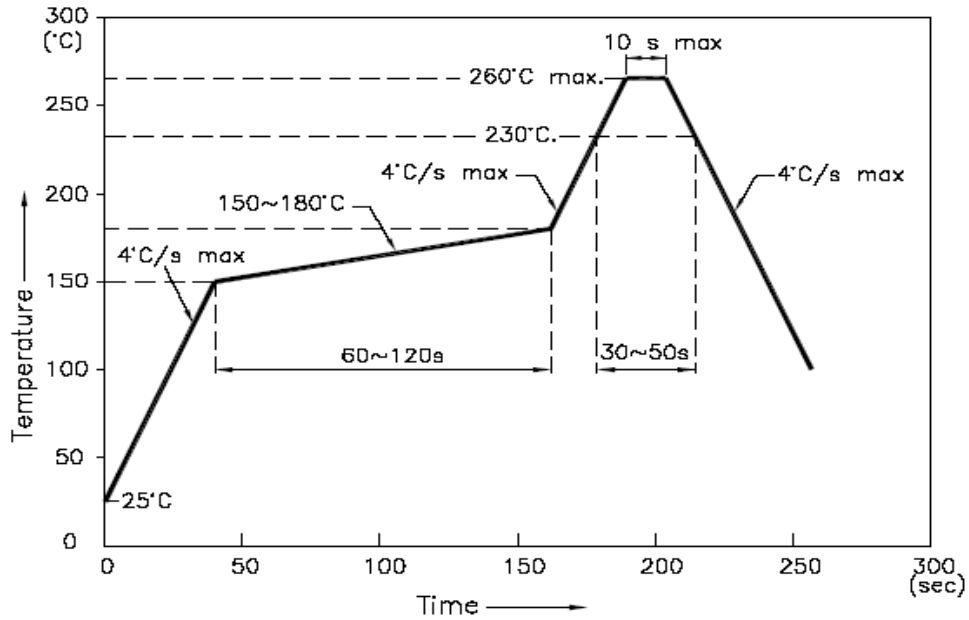

Recommended Pad Layout

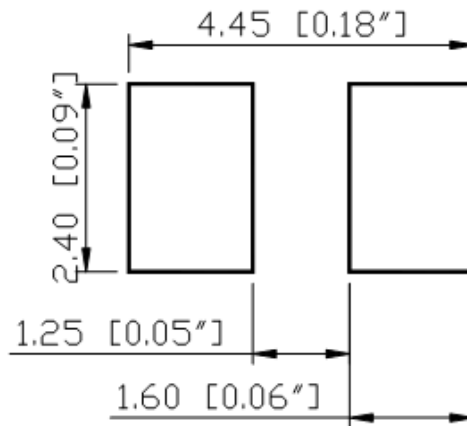

Units: mm

Packing

Reel Dimension:

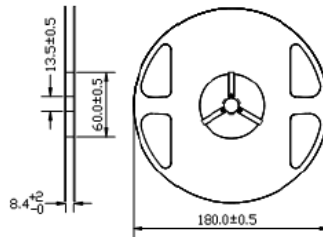

Unit: mm

Tape Dimension:

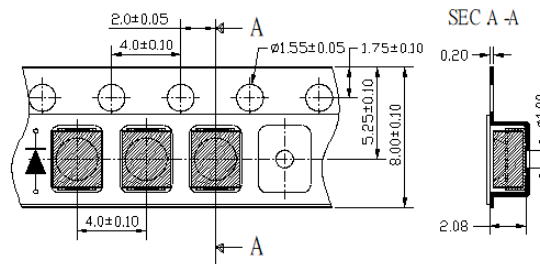

Unit: mm

Arrangement of Tape:

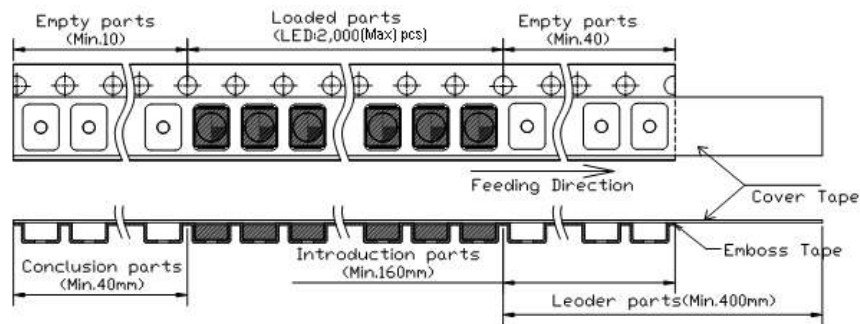

Packaging Specifications:

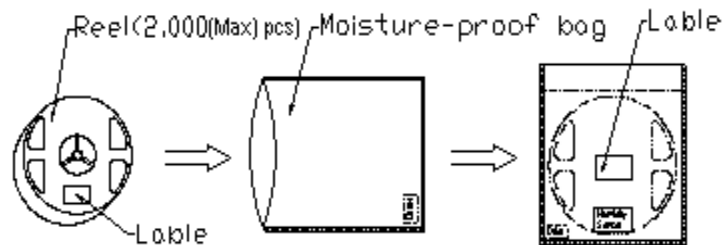

Labeling

Part No: _____

Customer P/N: _____

Item: _____

Q'ty: _____

Vf: _____

Iv: _____

WI: _____

Date: _____

Made in China**Ordering Information**

Part #	Orderable Part #	Spec Range	Quantity per reel
QBLP670-IW5	QBLP670-IW5	Iv=580mcd typ. @ 5mA / CIE Coordinate: (X=0.30, Y=0.287) typ.	2,000 units

Revision History

Description:	Revision #	Revision Date
New Release of QBLP670-IW5	V1.0	02/16/2022

Disclaimer

QT-BRIGHTTEK reserves the right to make changes without further notice to any products herein to improve reliability, function or design. QT-BRIGHTTEK does not assume any liability arising out of the application or use of any product or circuit described herein; neither does it convey any license under its patent rights, nor the rights of others.

Life Support Policy

QT-BRIGHTTEK's products are not authorized for use as critical components in life support devices or systems without the express written approval of QT-BRIGHTTEK. As used herein:

1. Life support devices or systems are devices or systems which, (a) are intended for surgical implant into the body, or (b) support or sustain life, and (c) whose failure to perform when properly used in accordance with instructions for use provided in the labeling, can be reasonably expected to result in a significant injury of the user.
2. A critical component in any component of a life support device or system whose failure to perform can be reasonably expected to cause the failure of the life support device or system, or to affect its safety or effectiveness.