

Data Sheet

HAL[®] 2455

High-Precision Programmable Linear
Hall-Effect Sensor with PWM Output

Copyright, Warranty, and Limitation of Liability

The information and data contained in this document are believed to be accurate and reliable. The software and proprietary information contained therein may be protected by copyright, patent, trademark and/or other intellectual property rights of TDK-Micronas. All rights not expressly granted remain reserved by TDK-Micronas.

TDK-Micronas assumes no liability for errors and gives no warranty representation or guarantee regarding the suitability of its products for any particular purpose due to these specifications.

By this publication, TDK-Micronas does not assume responsibility for patent infringements or other rights of third parties which may result from its use. Commercial conditions, product availability and delivery are exclusively subject to the respective order confirmation.

Any information and data which may be provided in the document can and do vary in different applications, and actual performance may vary over time.

All operating parameters must be validated for each customer application by customers' technical experts. Any mention of target applications for our products is made without a claim for fit for purpose as this has to be checked at system level.

Any new issue of this document invalidates previous issues. TDK-Micronas reserves the right to review this document and to make changes to the document's content at any time without obligation to notify any person or entity of such revision or changes. For further advice please contact us directly.

Do not use our products in life-supporting systems, military, aviation, or aerospace applications! Unless explicitly agreed to otherwise in writing between the parties, TDK-Micronas' products are not designed, intended or authorized for use as components in systems intended for surgical implants into the body, or other applications intended to support or sustain life, or for any other application in which the failure of the product could create a situation where personal injury or death could occur.

No part of this publication may be reproduced, photocopied, stored on a retrieval system or transmitted without the express written consent of TDK-Micronas.

TDK-Micronas Trademarks

– HAL

Third-Party Trademarks

All other brand and product names or company names may be trademarks of their respective companies.

Contents

Page	Section	Title
4	1.	Introduction
5	1.1.	Major Applications
5	1.2.	Features
6	2.	Ordering Information
6	2.1.	Device-Specific Ordering Codes
7	3.	Functional Description
7	3.1.	General Function
9	3.2.	Signal Path and Register Definition
9	3.2.1.	Signal Path
9	3.2.2.	Register Definition
10	3.2.2.1.	RAM registers
13	3.2.2.2.	EEPROM Registers
17	3.2.2.3.	NVRAM Registers
18	3.2.2.4.	Setpoint Linearization Accuracy
19	3.3.	On-Board Diagnostic Features
20	3.4.	Calibration of the Sensor
21	4.	Specifications
21	4.1.	Outline Dimensions
27	4.2.	Soldering, Welding and Assembly
27	4.3.	Pin Connections and Short Descriptions
27	4.4.	Sensitive Area
27	4.4.1.	Dimensions
28	4.5.	Absolute Maximum Ratings
29	4.5.1.	Storage and Shelf Life
29	4.6.	Recommended Operating Conditions
30	4.7.	Characteristics
31	4.8.	Overvoltage and Undervoltage Detection
31	4.9.	Magnetic Characteristics
32	4.9.1.	Definition of Sensitivity Error ES
33	5.	Application Notes
33	5.1.	Application Circuit
33	5.2.	Measurement of a PWM Output Signal of HAL 2455
34	5.3.	Use of two HAL 2455 in Parallel
34	5.4.	Ambient Temperature
34	5.5.	EMC and ESD
35	6.	Programming of the Sensor
35	6.1.	Programming Interface
37	6.2.	Programming Environment and Tools
37	6.3.	Programming Information
38	7.	Document History

High-Precision Programmable Linear Hall-Effect Sensor with PWM Output

Release Note: Revision bars indicate significant changes to the previous edition.

1. Introduction

The HAL 2455 is a member of the HAL 24xy family of programmable linear Hall-effect sensors from TDK-Micronas.

The device is a universal magnetic-field sensor based on the Hall effect featuring a PWM output. Major characteristics like magnetic-field range, and sensitivity are programmable in a non-volatile memory. The sensor offers wire-break detection.

The HAL 2455 offers 16 setpoints to change the output characteristics from linear to arbitrary or vice versa.

The HAL 2455 features a temperature-compensated Hall plate with spinning-current offset compensation, an A/D converter, digital signal processing, a PWM output module, an EEPROM with redundancy and lock function for calibration data, a serial interface for programming the EEPROM, and protection devices at all pins. The internal digital signal processing prevents the signal being influenced by analog offsets, temperature shifts, and mechanical stress.

The easy programmability allows a 2-point calibration by adjusting the output signal directly to the input signal (like mechanical angle, distance, or current). Individual adjustment of each sensor during the final manufacturing process is possible. With this calibration procedure, the tolerances of the sensor, the magnet and the mechanical positioning can be compensated in the final assembly.

In addition, the temperature compensation of the Hall IC can be fit to all common magnetic materials by programming first- and second-order temperature coefficients of the Hall sensor sensitivity.

It is also possible to compensate offset drift over temperature generated by the customer application with a first-order temperature coefficient for the sensor's offset. This enables operation over the full temperature range with high accuracy.

The calculation of the individual sensor characteristics and the programming of the EEPROM can easily be done with a PC and the application kit from TDK-Micronas.

The sensor is designed for stringent industrial and automotive applications and is AECQ100 qualified. It operates with typically 5 V supply voltage in the junction temperature range from $-40\text{ }^{\circ}\text{C}$ up to $170\text{ }^{\circ}\text{C}$. The HAL 2455 is available in the 3-pin package TO92UT-1/-2 and SOIC8 SMD packages.

1.1. Major Applications

Due to the sensor's versatile programming characteristics and low temperature drifts, the HAL 2455 is the optimal system solution for applications such as:

- Contactless potentiometers,
- Angle sensors (e.g. for transmission applications)
- Distance and linear movement measurements

1.2. Features

- High-precision linear Hall-effect sensor with 12-bit accuracy and PWM output up to 2 kHz
- 16 setpoints for various output signal shapes
- 16 bit digital signal processing
- Multiple customer-programmable magnetic characteristics in a non-volatile memory with redundancy and lock function
- Programmable temperature compensation for sensitivity and offset
- Magnetic field measurements in the range up to ± 200 mT
- Active open-circuit (ground and supply line break detection) with 5 k Ω pull-up and pull-down resistor, overvoltage and undervoltage detection
- Programmable clamping function
- Digital readout of temperature and magnetic field information in calibration mode
- Programming and operation of multiple sensors at the same supply line
- High immunity against mechanical stress, ESD, and EMC
- Operates from $T_J = -40$ °C up to 170 °C
- Operates from 4.5 V up to 5.5 V supply voltage in specification and functions up to 8.5 V
- Operates with static magnetic fields and dynamic magnetic fields up to 2 kHz
- Overvoltage and reverse-voltage protection at all pins

2. Ordering Information

A Micronas device is available in a variety of delivery forms. They are distinguished by a specific ordering code:

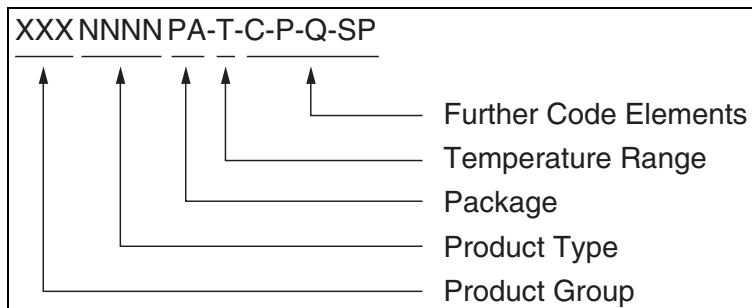

Fig. 2–1: Ordering Code Principle

For a detailed information, please refer to the brochure: “Micronas Sensors and Controllers: Ordering Codes, Packaging, Handling”.

2.1. Device-Specific Ordering Codes

HAL 2455 is available in the following package and temperature variants.

Table 2–1: Available packages

Package Code (PA)	Package Type
UT	TO92UT-1/-2
DJ	SOIC8-1

Table 2–2: Available temperature range

Temperature Code (T)	Temperature Range
A	$T_J = -40\text{ °C to }+170\text{ °C}$

The relationship between ambient temperature (T_A) and junction temperature (T_J) is explained in Section 5.4. on page 34.

For available variants for Configuration (C), Packaging (P), Quantity (Q), and Special Procedure (SP) please contact TDK-Micronas.

Table 2–3: Available ordering codes and corresponding package marking

Available Ordering Codes	Package Marking
HAL2455UT-A-[C-P-Q-SP]	2455A
HAL2455DJ-A-[C-P-Q-SP]	2455A

3. Functional Description

3.1. General Function

The HAL 2455 is an integrated circuit which provides a PWM output signal proportional to the magnetic flux through the Hall plate.

The external magnetic field component perpendicular to the branded side of the package generates a Hall voltage. The Hall IC is sensitive to magnetic north and south polarity. This voltage is converted to a digital value, processed in the Digital Signal Processing Unit (DSP) according to the settings of the EEPROM registers, and output as PWM signal.

The setting of a LOCK bit disables the programming of the EEPROM memory for all time. This bit cannot be reset by the customer.

As long as the LOCK bit is not set, the output characteristic can be adjusted by programming the EEPROM registers. The IC is addressed by modulating the output voltage.

In the supply voltage range from 4.5 V up to 5.5 V, the sensor generates a PWM signal. After detecting a command, the sensor reads or writes the memory and answers with a digital signal on the output pin. Several sensors in parallel to the same supply and ground line can be programmed individually. The selection of each sensor is done via its output pin. See “Programming Guide HAL 24xy and HAR 24xy”.

The open-circuit detection provides a defined output voltage if the V_{SUP} or GND line is broken.

Internal temperature compensation circuitry and the spinning-current offset compensation enable operation over the full temperature range with minimal changes in accuracy and high offset stability. The circuitry also reduces offset shifts due to mechanical stress from the package. In addition, the sensor IC is equipped with devices for overvoltage and reverse-voltage protection at all pins.

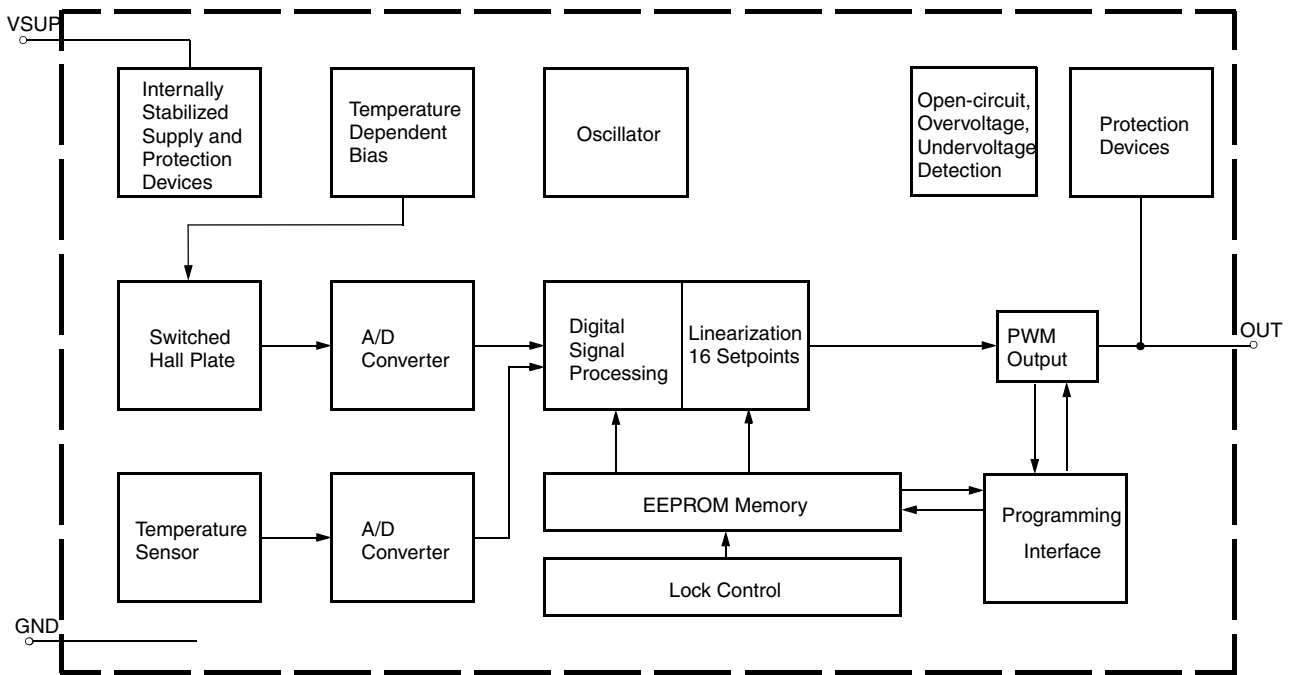

Fig. 3–1: HAL 2455 block diagram

3.2. Signal Path and Register Definition

3.2.1. Signal Path

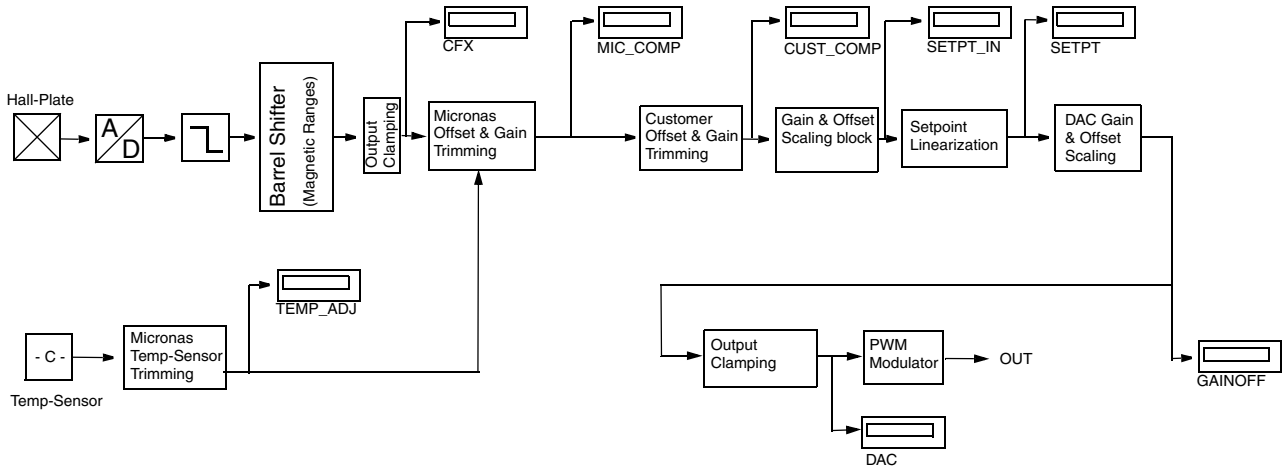

Fig. 3–2: Signal path of HAL 2455

3.2.2. Register Definition

The DSP is the major part of this sensor and performs the signal conditioning. The parameters for the DSP are stored in the EEPROM registers. The details are shown in Fig. 3–2 and Fig. 3–3.

Terminology:

GAIN: Name of the register or register value

Gain: Name of the parameter

The sensors signal path contains two kinds of registers. Registers that are readout only (RAM) and programmable registers (EEPROM & NVRAM). The RAM registers contain measurement data at certain positions of the signal path and the EEPROM registers have influence on the sensors signal processing.

3.2.2.1. RAM registers

TEMP_ADJ

The TEMP_ADJ register contains the calibrated temperature sensor information. TEMP_ADJ can be used for the sensor calibration over temperature. This register has a length of 16 bit and it is two's-complement coded. Therefore the register value can vary between $-32768 \dots 32767$.

CFX

The CFX register is representing the magnetic field information directly after A/D conversion, decimation filter and magnetic range (barrel shifter) selection. The register content is not temperature compensated. The temperature variation of this register is specified in Section 4.9. on page 31 by the parameter RANGE_{ABS}.

Note

During application design, it must be taken into consideration that CFX should never overflow in the operational range of the specific application and especially over the full temperature range. In case of a potential overflow the barrel shifter should be switched to the next higher range.

This register has a length of 16 bit and it is two's-complement coded. Therefore, the register value can vary between $-32768 \dots 32767$. CFX register values will increase for positive magnetic fields (south pole) on the branded side of the package (positive CFX values) and it will decrease with negative magnetic field polarity.

MIC_COMP

The MIC_COMP register is representing the magnetic field information directly after the Micronas temperature trimming. The register content is temperature compensated and has a typical gain drift over temperature of 0 ppm/k. Also the offset and its drift over temperature is typically zero. The register has a length of 16 bit and it is two's-complement coded. Therefore the register value can vary between $-32768 \dots 32767$.

CUST_COMP

The CUST_COMP register is representing the magnetic field information after the customer temperature trimming. For HAL 2455 it is possible to set a customer specific gain of second order over temperature as well as a customer specific offset of first order over temperature. The customer gain and offset can be set with the EEPROM registers TCCO0, TCCO1 for offset and TCCG0... TCCG2 for gain. Details of these registers are described on the following pages.

The register has a length of 16 bit and it is two's-complement coded. Therefore the register value can vary between $-32768 \dots 32767$.

SETPT_IN

The SETPT_IN register offers the possibility to read the magnetic field information after the scaling of the input signal to the input range of the linearization block. For further details see the description of the EEPROM registers SCALE_GAIN and SCALE_OFFSET that are described in the next chapter.

The register has a length of 16 bit and it is two's-complement coded. Therefore the register value can vary between $-32768 \dots 32767$.

SETPT

The SETPT register offers the possibility to read the magnetic field information after the linearization of the magnetic field information with 16 setpoints. This information is also required for the correct setting of the sensors DAC GAIN and OFFSET in the following block.

The register has a length of 16 bit and it is two's-complement coded. Therefore the register value can vary between $-32768 \dots 32767$.

GAINOFF

The GAINOFF register offers the possibility to read the magnetic field information after the DAC GAIN and OFFSET scaling.

This register has a length of 16 bit and it is two's-complement coded. Therefore the register value can vary between $-32768 \dots 32767$.

MIC_ID1 and MIC_ID2

The two registers MIC_ID1 and MIC_ID2 are used by TDK-Micronas to store production information like, wafer number, die position on wafer, production lot, etc. Both registers have a length of 16 bit each and are readout only.

PWM Frequency

The PWM frequency is selectable by 2 bits, which are part of the CUSTOMER SETUP register (bits 11:10). The CUSTOMER SETUP register is described on the following pages. The following four different frequencies can be used:

Table 3–1: Selectable PWM frequencies

PWM_FREQ		Frequency	Resolution
Bit 11	Bit 10		
1	1	2 kHz	11 bit
0	0	1 kHz	12 bit
0	1	500 Hz	12 bit
1	0	250 Hz	12 bit

DIAGNOSIS

The DIAGNOSIS register enables the customer to identify certain failures detected by the sensor. HAL 2455 performs certain self tests during power-up of the sensor and also during normal operation. The result of these self tests is stored in the DIAGNOSIS register. DIAGNOSIS register is a 16 bit register.

Bit No.	Function	Description
15:6	None	Reserved
5	State Machine (DSP) Self test	This bit is set to 1 in case that the statemachine self test fails. (continuously running)
4	EEPROM Self test	This bit is set to 1 in case that the EEPROM self test fails. (Performed during power-up only)
3	ROM Check	This bit is set to 1 in case that ROM parity check fails. (continuously running)
2	AD converter overflow	This bit is set to 1 in case the input signal is too high, indicating a problem with the magnetic range.
1:0	None	Reserved

Details on the sensor self tests can be found in Section 3.3. on page 19.

PROG_DIAGNOSIS

The PROG_DIAGNOSIS register enables the customer to identify errors occurring during programming and writing of the EEPROM or NVRAM memory. The customer must either check the status of this register after each write or program command or alternatively the second acknowledge. Please check the Programming Guide for HAL 24xy.

The PROG_DIAGNOSIS register is a 16 bit register. The following table shows the different bits indicating certain errors possibilities.

Bit no.	Function	Description
15:11	None	Reserved
10	Charge Pump Error	This bit is set to 1 in case that the internal programming voltage was to low
9	Voltage Error during Program/Erase	This bit is set to 1 in case that the internal supply voltage was to low during program or erase
8	NVRAM Error	This bit is set to 1 in case that the programming of the NVRAM failed
7:0	Programming	For further information please refer to the Programming Guide for HAL 24xy

3.2.2.2. EEPROM Registers

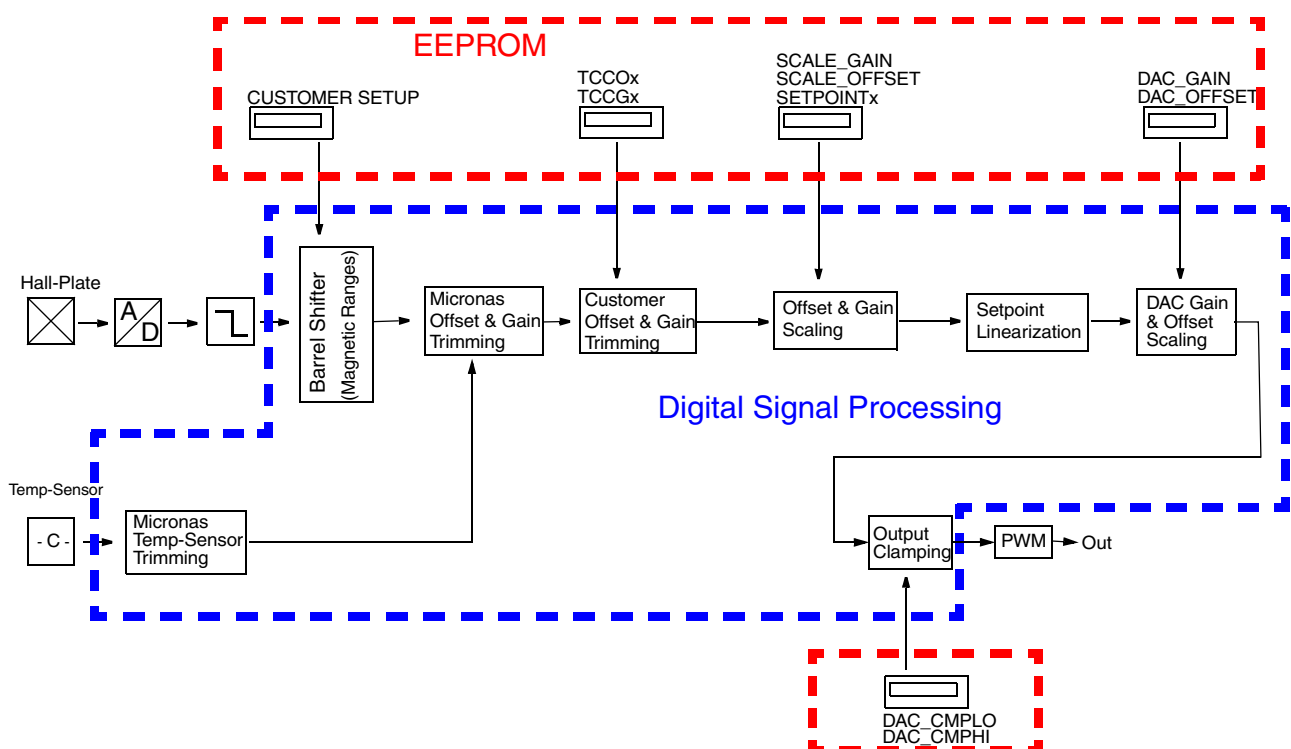

Fig. 3–3: Details of EEPROM and Digital Signal Processing

CUST_ID1 and CUST_ID2

The two registers CUST_ID1 and CUST_ID2 can be used to store customer information. Both registers have a length of 16 bit each.

Barrel Shifter (Magnetic Ranges)

The signal path of HAL 2455 contains a Barrel Shifter to emulate magnetic ranges. The customer can select between different magnetic ranges by changing the Barrel shifter setting. After decimation filter the signal path has a word length of 22 bit. The Barrel Shifter selects 16 bit out of the available 22 bit.

Table 3–2: Relation between Barrel Shifter setting and emulated magnetic range

BARREL SHIFTER	Used bits	Typ. magnetic range
0	22...7	not used
1	21...6	± 200 mT
2	20...5	± 100 mT
3	19...4	± 50 mT
4	18...3	± 25 mT
5	17...2	± 12 mT
6	16...1	± 6 mT

The Barrel Shifter bits are part of the CUSTOMER SETUP register (bits 14...12). The CUSTOMER SETUP register is described on the following pages.

Note In case that the external field exceeds the magnetic field range, the CFX register will be clamped either to –32768 or 32767 depending on the sign of the magnetic field.

Magnetic Sensitivity TCCG

The TCCG (Sensitivity) registers (TCCG0...TCCG2) contain the customer setting temperature dependant gain factor. The multiplication factor is a second order polynomial of the temperature.

All three polynomial coefficients have a bit length of 16 bit and they are two's-complement coded. Therefore the register values can vary between $-32768...32767$. In case that the target polynomial is based on normalized values, then each coefficient can vary between $-4 ... +4$. To store each coefficient into the EEPROM it is necessary to multiply the normalized coefficients with 32768.

Example:

$$- \text{Tccg0} = 0.5102 \Rightarrow \text{TCCG0} = 16719$$

$$- \text{Tccg1} = -0.0163 \Rightarrow \text{TCCG1} = -536$$

$$- \text{Tccg2} = 0.0144 \Rightarrow \text{TCCG2} = 471$$

In case that the polynomial was calculated based on not normalized values of TEMP_ADJ and MIC_COMP, then it is not necessary to multiply the polynomial coefficients with a factor of 32768.

Magnetic Offset TCCO

The TCCO (Offset) registers (TCCO0 and TCCO1) contain the parameters for temperature dependant offset correction. The offset value is a first order polynomial of the temperature.

Both polynomial coefficients have a bit length of 16 bit and they are two's-complement coded. Therefore the register values can vary between $-32768...32767$.

In case that the target polynomial is based on normalized values, then each coefficient can vary between $-4 ... +4$. To store each coefficient into the EEPROM it is necessary to multiply the normalized coefficients with 32768.

In case that the polynomial was calculated based on not normalized values of TEMP_ADJ and MIC_COMP, then it is not necessary to multiply the polynomial coefficients.

SETPOINTS

HAL 2455 features a linearization function based on 16 setpoints. The setpoint linearization in general allows to linearize a given output characteristic by applying the inverse compensation curve.

Each of the 16 setpoints (SETPT) registers has a length of 16 bit. The setpoints have to be computed and stored in a differential way. This means that if all setpoints are set to 0, then the linearization is set to neutral and a linear curve is used.

Sensitivity and Offset Scaling before Setpoint Linearization SCALE_GAIN/ SCALE_OFFSET

The setpoint linearization uses the full 16 bit number range 0...32767 (only positive values possible). So the signal path should be properly scaled for optimal usage of all 16 setpoints.

For optimum usage of the number range an additional scaling stage is added in front of the set point algorithm. The setpoint algorithm allows positive input numbers only.

The input scaling for the linearization stage is done with the EEPROM registers SCALE_GAIN and SCALE_OFFSET. The register content is calculated based on the calibration angles. Both registers have a bit length of 16 bit and are two's-complemented coded.

Output Signal Scaling with DAC_GAIN/DAC_OFFSET

The required output duty cycle of the output is defined by the registers DAC_GAIN (Gain of the output) and DAC_OFFSET (Offset of the output signal). Both register values can be calculated based on the angular range and the required output PWM duty cycle range. They have a bit length of 16 bit and are two's-complemented coded.

Clamping Levels DAC_CMPHI/DAC_CMPLO

The clamping levels DAC_CMPHI and DAC_CMPLO define the duty cycle of the output and define the diagnosis band for the sensor output. Both registers have a bit length of 16 bit and are two's-complemented coded. Both clamping levels can have values between 0% and 100% of full scale.

3.2.2.3. NVRAM Registers

Customer Setup

The CUST_SETUP register is a 16 bit register that enables the customer to activate various functions of the sensor like customer burn-in mode, diagnosis modes, functionality mode, customer lock, etc.

Bit OP configures the PWM output polarity: a PWM period starts either with a high pulse (OP = 0) or with a low pulse (OP = 1). Please note that OP set to 1 is only effective after the device had been locked (LC=1)

Table 3–3: Functions in CUST_SETUP register

Bit No.	Function	Description
15	None	Reserved
14:12	Barrel Shifter	Magnetic Range (see Section Table 3–2: on page 14)
11:10	PWM frequency setting	PWM frequency selection (see Table 3–1 on page 12)
9:8	None	Reserved
7	PWM Output Polarity (OP)	0: PWM period starts with a high pulse 1: PWM period starts with a low pulse (effective after LC=1)
6	None	Reserved
5	Functionality Mode	1: Normal
4	Communication Mode (POUT)	Communication via output pin 0: Disabled 1: Enabled
3	Overvoltage Detection	0: Overvoltage detection active 1: Overvoltage detection disabled
2	Diagnosis Latch	Latching of diagnosis bits 0: No latching 1: Latched till next POR (power-on reset)
1	Diagnosis	0: Diagnosis errors force the PWM output into error mode (see Table 3–4) 1: Diagnosis errors do not force the PWM output into error mode
0	Customer Lock (LC)	Bit must be set to 1 to lock the sensor memory

3.2.2.4. Setpoint Linearization Accuracy

The set point linearization in general allows to linearize a given output characteristic by applying the inverse compensation curve.

For this purpose the compensation curve will be divided into 16 segments with equal distance. Each segment is defined by two setpoints, which are stored in EEPROM. Within the interval, the output is calculated by linear interpolation according to the position within the interval.

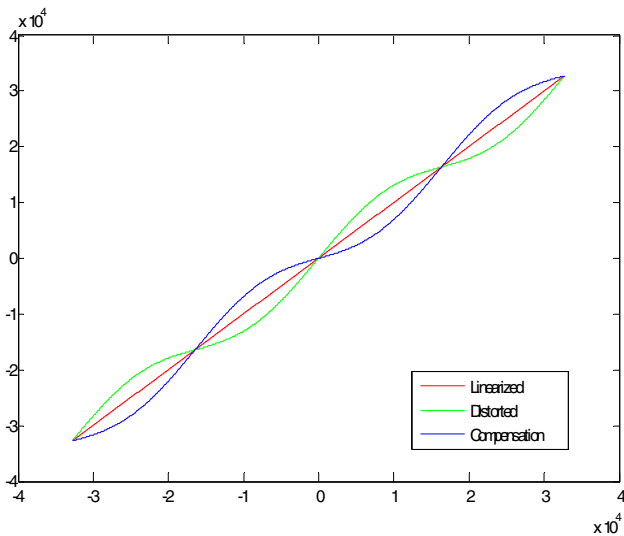

Fig. 3–4: Linearization - Principle

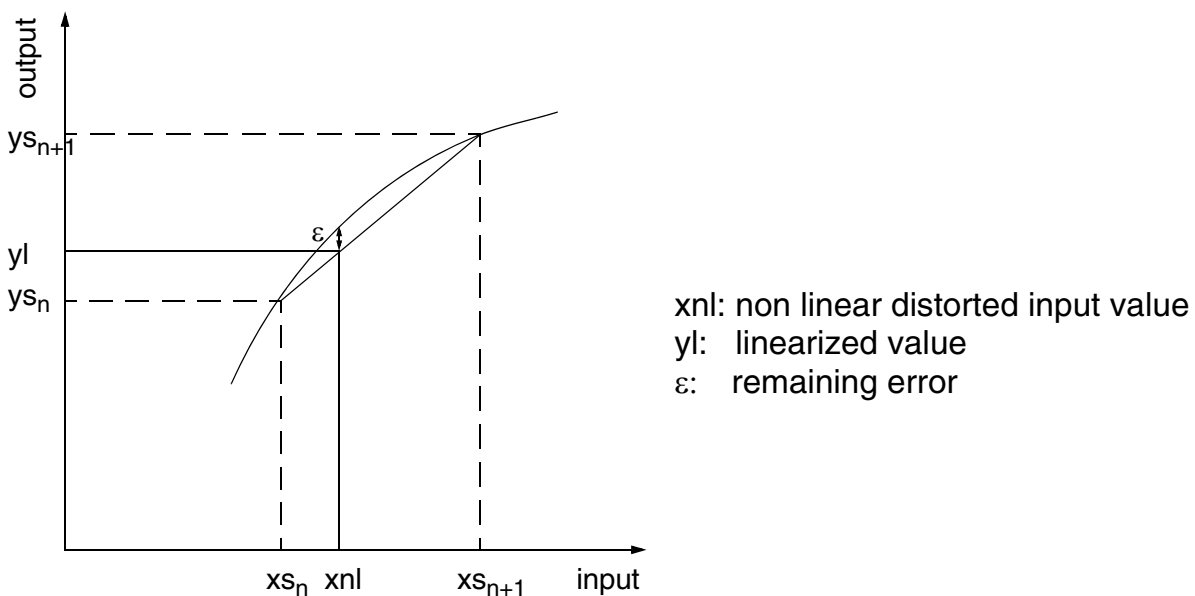

Fig. 3–5: Linearization - Detail

The constraint of the linearization is that the input characteristic has to be a monotonic function. In addition to that it is recommended that the input does not have a saddle point or inflection point, i.e. regions where the input is nearly constant. This would require a high density of setpoints.

3.3. On-Board Diagnostic Features

The HAL 2455 features two groups of diagnostic functions. The first group contains basic functions that are always active. The second group can be activated by the customer and contains supervision and self-tests related to the signal path and sensor memory.

Diagnostic Features that are Always Active:

- Wire break detection for supply and ground line
- Undervoltage detection
- Thermal supervision of output stage: overcurrent, short circuit, etc.

Diagnostic Features that can be Activated by Customer:

- Overvoltage detection
- EEPROM self-test at power-on
- Continuous ROM parity check
- Continuous state machine self-test
- Adder overflow

Failure Indication

The HAL 2455 indicates a failure by changing the PWM frequency. The different errors are then coded in different duty-cycles.

Table 3–4: Failure indication for HAL 2455

Failure Mode	Frequency	Duty-Cycle
EEPROM and state machine self-test	50%	95%
Adder overflow	50%	85%
Overvoltage	50%	75%
Undervoltage	50%	100%

Note

In case of an error, the sensor changes the selected PWM frequency.

Example:

During normal operation, the PWM frequency is 1 kHz, in case of an error 500 Hz.

3.4. Calibration of the Sensor

For calibration in the system environment, the application kit from TDK-Micronas is recommended. It contains the hardware for the generation of the serial telegram for programming and the corresponding LabView™ based programming environment for the input of the register values (see Section 6.2. on page 37).

For the individual calibration of each sensor in the customer application, a two point calibration is recommended.

A detailed description of the calibration software example provided by TDK-Micronas, calibration algorithm, programming sequences and register value calculation can be found in the Application Note “HAL 24xy Programming Guide”.

4. Specifications

4.1. Outline Dimensions

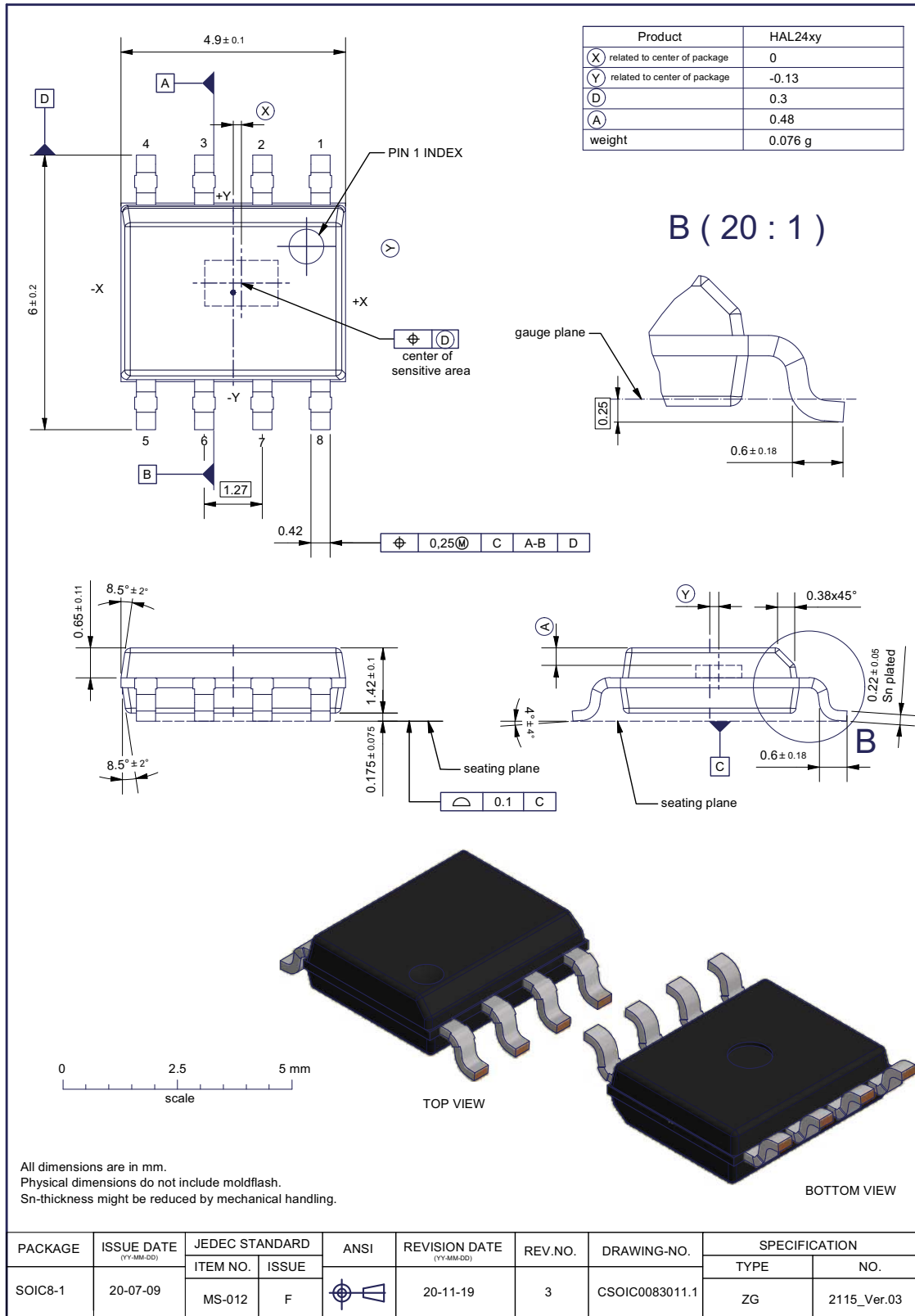

All dimensions are in mm.
Physical dimensions do not include moldflash.
Sn-thickness might be reduced by mechanical handling.

PACKAGE	ISSUE DATE (YY-MM-DD)	JEDEC STANDARD		ANSI	REVISION DATE (YY-MM-DD)	REV.NO.	DRAWING-NO.	SPECIFICATION	
		ITEM NO.	ISSUE					TYPE	NO.
SOIC8-1	20-07-09	MS-012	F		20-11-19	3	CSOIC0083011.1	ZG	2115_Ver.03

Copyright 2018 TDK-Micronas GmbH, all rights reserved

Fig. 4-1:
SOIC8-1: Plastic Small Outline IC package, 8 leads, gullwing bent, 150 mil
Ordering code: DJ

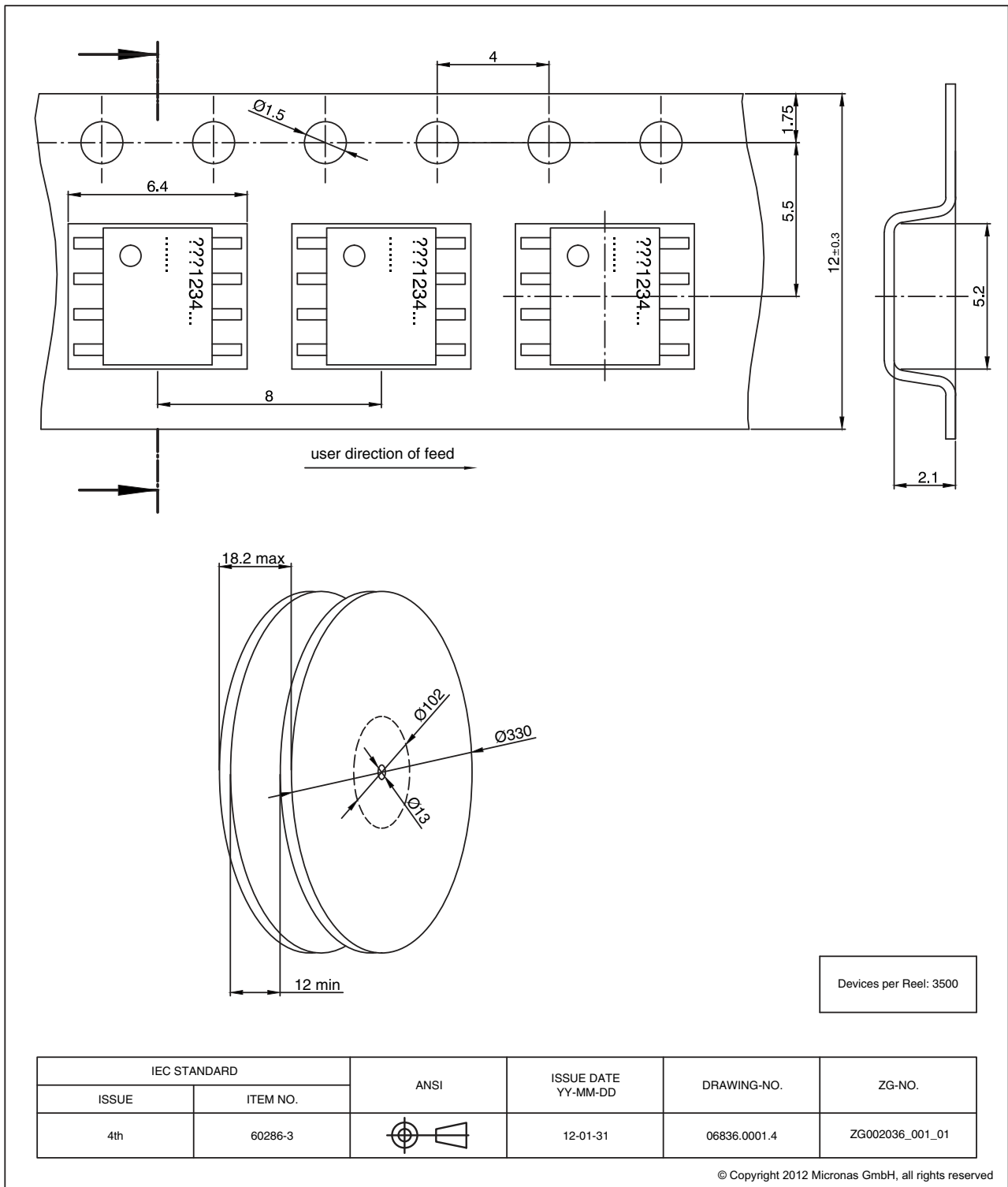

Fig. 4-2:
SOIC8: Tape and Reel Finishing

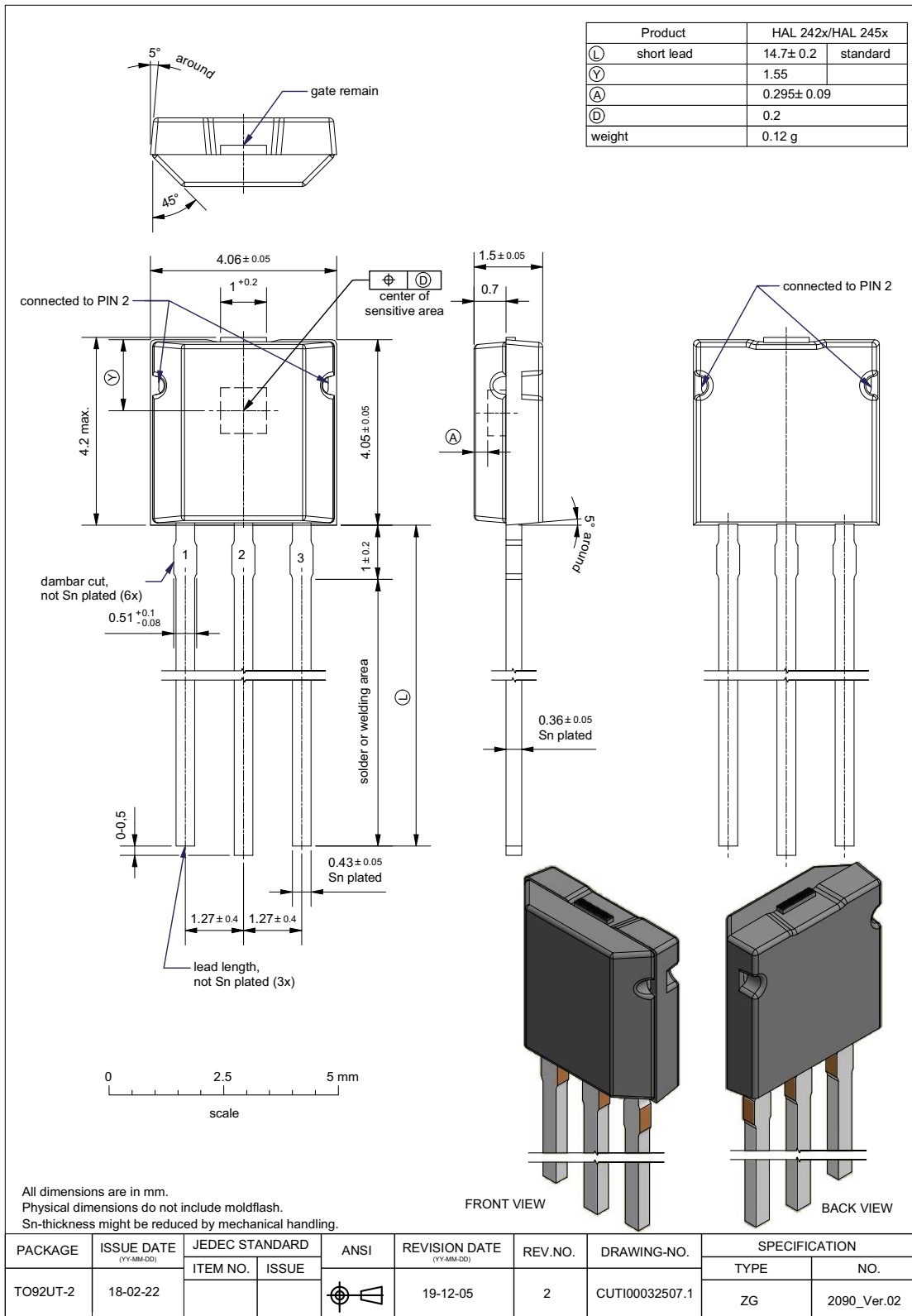

Fig. 4-3:
TO92UT-2 Plastic Transistor Standard UT package, 3 leads, non-spread

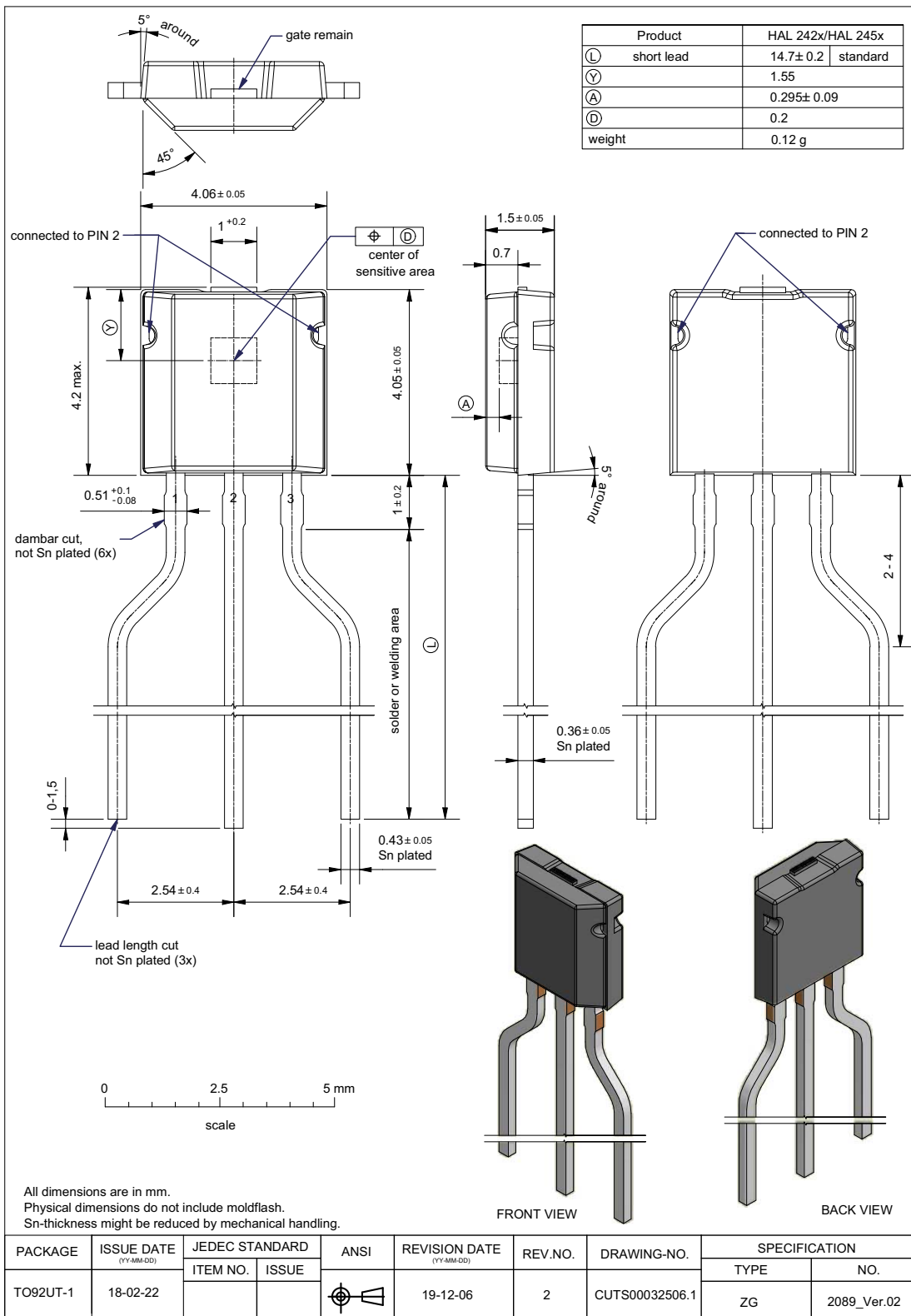

Fig. 4-4:
TO92UT-1 TO92UT-1 Plastic Transistor Standard UT package, 3 leads, spread

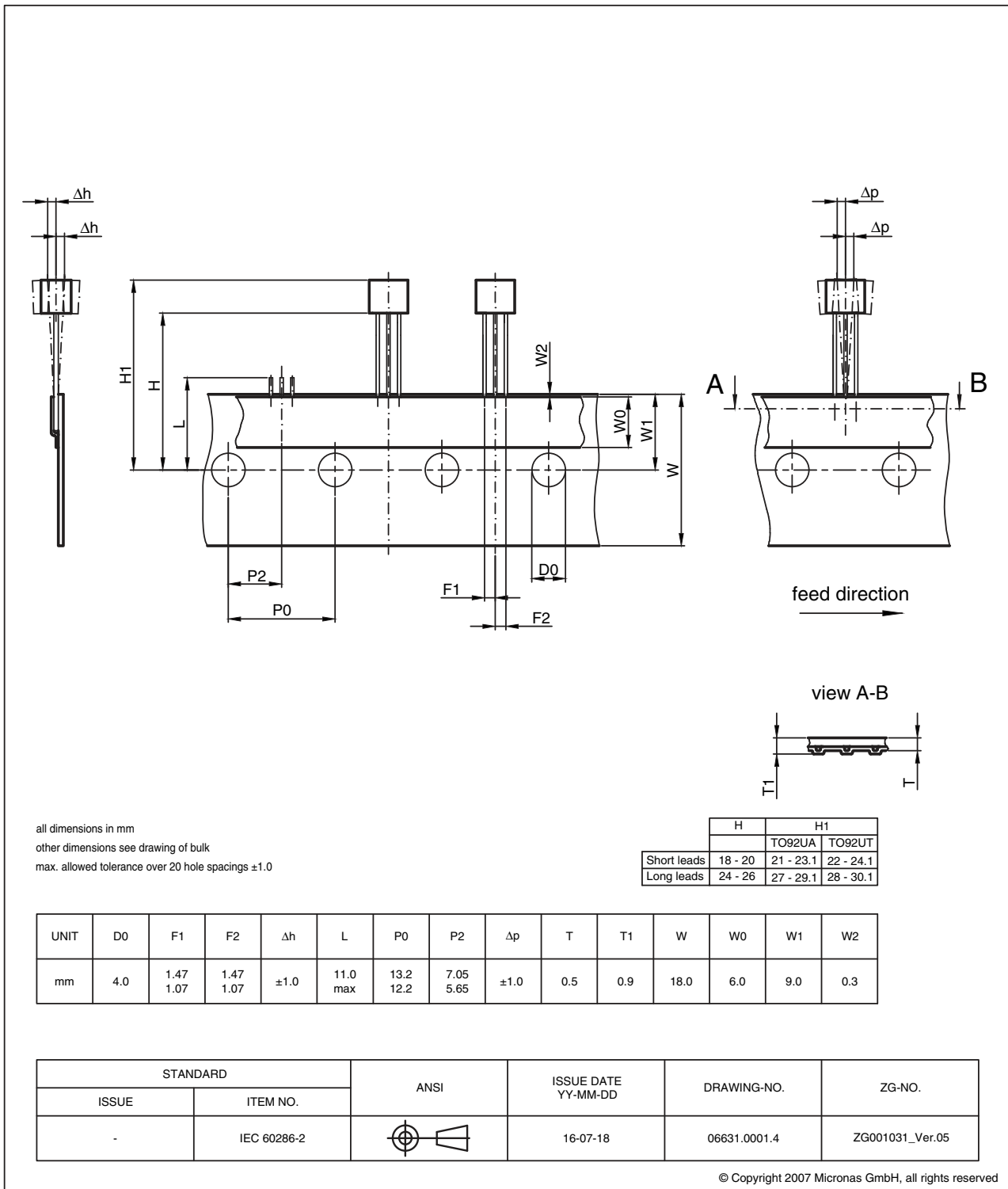

Fig. 4–5:
TO92UA/UT: Dimensions ammpack inline, not spread

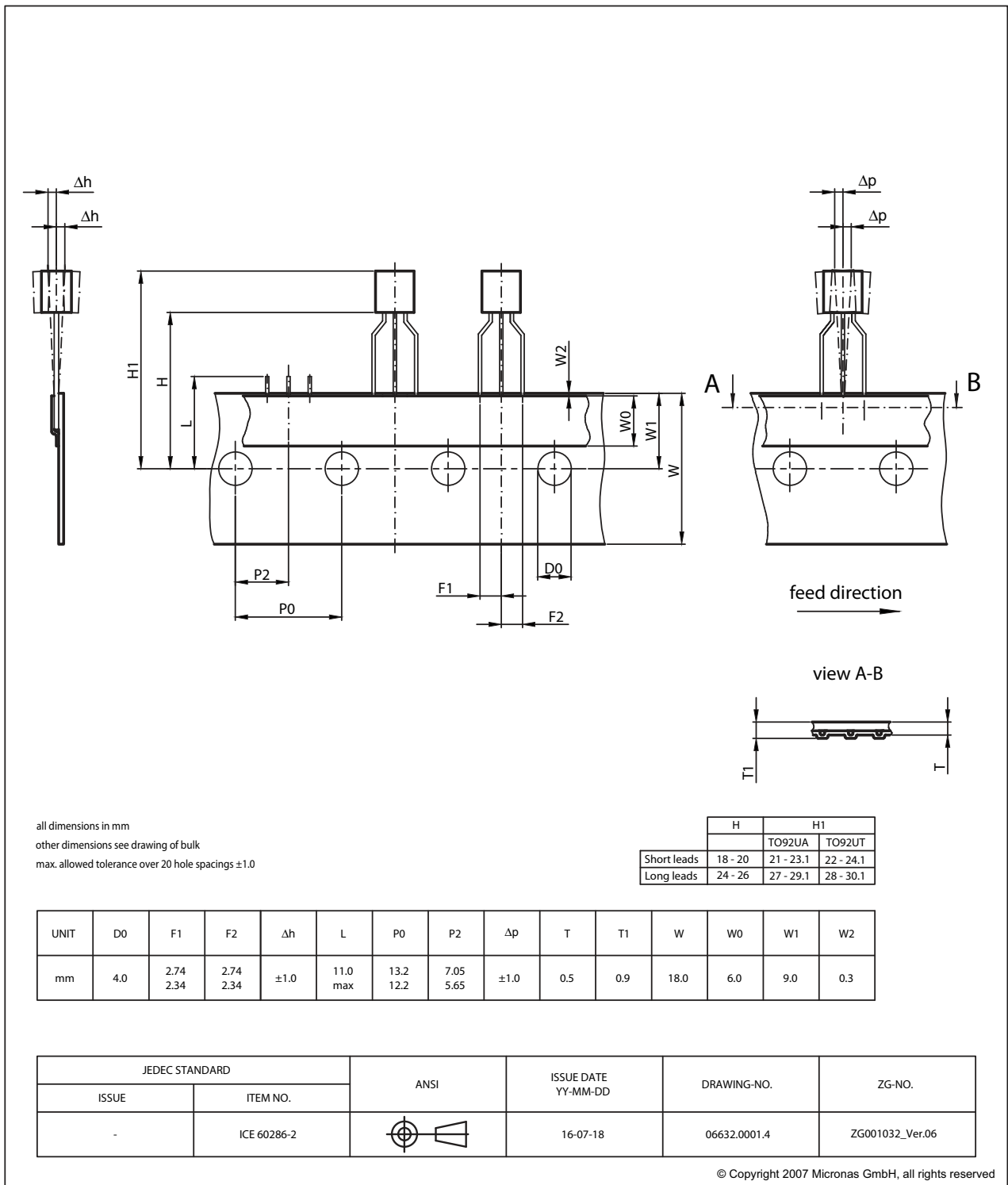

Fig. 4-6:
TO92UA/UT: Dimensions ammpack inline, spread

4.2. Soldering, Welding and Assembly

Information related to solderability, welding, assembly, and second-level packaging is included in the document “Guidelines for the Assembly of Micronas Packages”.

It is available on the TDK-Micronas website (<http://www.micronas.com/en/service-center/downloads>) or on the service portal (<http://service.micronas.com>).

4.3. Pin Connections and Short Descriptions

Table 4–1: SOIC8 package

Pin No	Pin Name	Type	Short Description
1	VSUP	SUPPLY	Supply Voltage
2	GND	GND	Ground
4	OUT	I/O	Output and Programming Pin

All remaining pins (3, 5, 6, 7, 8) must be connected to ground

Table 4–2: TO92UT package

Pin No	Pin Name	Type	Short Description
1	VSUP	SUPPLY	Supply Voltage
2	GND	GND	Ground
3	OUT	I/O	Output and Programming Pin

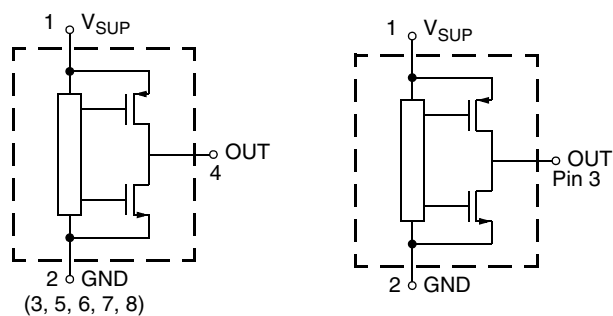

SOIC8 package

TO92UT package

Fig. 4–7: Pin configuration in SOIC8 and TO92UT package

4.4. Sensitive Area

4.4.1. Dimensions

250 μm x 250 μm

4.5. Absolute Maximum Ratings

Stresses beyond those listed in the “Absolute Maximum Ratings” may cause permanent damage to the device. This is a stress rating only. Functional operation of the device at these conditions is not implied. Exposure to absolute maximum rating conditions for extended periods will affect device reliability.

This device contains circuitry to protect the inputs and outputs against damage due to high static voltages or electric fields; however, it is advised that normal precautions must be taken to avoid application of any voltage higher than absolute maximum-rated voltages to this circuit.

All voltages listed are referenced to ground (GND).

Symbol	Parameter	Pin	Min.	Max.	Unit	Condition
V_{SUP}	Supply Voltage	VSUP	-8.5	10	V	$t < 96 \text{ h}^{4)}$
			-18	18	V	$t < 1 \text{ h}^{4)}$
V_{OUT}	Output Voltage	OUT	-6 ¹⁾	18	V	$t < 1 \text{ h}^{4)}$
$V_{OUT} - V_{SUP}$	Excess of Output Voltage over Supply Voltage	VSUP, OUT	-	2	V	
T_J	Junction Temperature under Bias		-50	190 ²⁾	°C	
$T_{storage}$	Transportation/Short-Term Storage Temperature		-50	150	°C	Device only without packing material
V_{ESD_SOIC8}	ESD Protection for SOIC8 package ³⁾	All Pins	-2	2	kV	HBM AEC-Q-100-002 (100 pF / 1.5 kΩ)
		VSUP vs. GND	-8	8	kV	
		OUT vs. GND	-8	8	kV	
		VSUP vs. OUT	-8	8	kV	
V_{ESD_TO92}	ESD Protection for TO92UT package ³⁾	All Pins	-8	8	kV	HBM AEC-Q-100-002 (100 pF / 1.5 kΩ)
¹⁾ internal protection resistor = 50 Ω ²⁾ For 96h, please contact TDK-Micronas for other temperature requirements. ³⁾ For system ESD robustness, pins not used have to be connected to GND. ⁴⁾ No cumulated stress						

4.5.1. Storage and Shelf Life

Information related to storage conditions of Micronas sensors is included in the document “Guidelines for the Assembly of Micronas Packages”. It gives recommendations linked to moisture sensitivity level and long-term storage.

It is available on the TDK-Micronas website (<http://www.micronas.com/en/service-center/downloads>) or on the service portal (<http://service.micronas.com>).

4.6. Recommended Operating Conditions

Functional operation of the device beyond those indicated in the “Recommended Operating Conditions/Characteristics” is not implied and may result in unpredictable behavior, reduce reliability and lifetime of the device.

All voltages listed are referenced to ground (GND).

Symbol	Parameter	Pin	Min.	Typ.	Max.	Unit	Remarks
V _{SUP}	Supply Voltage	VSUP	4.5 5.7	5 6	5.5 6.5	V	Normal operation During programming
I _{OUT}	Continuous Output Current	OUT	-1.2	-	5	mA	
R _L	Load Resistor	OUT	1.0	-	-	kΩ	Pull-up resistor only
C _L	Load Capacitance	OUT	-	0.18	10	nF	
N _{PRG}	Number of Memory Programming Cycles ¹⁾	-	-	-	100	cycles	0°C < T _{amb} < 55°C
T _J	Junction Temperature ²⁾	-	-40 -40 -40	-	125 150 170	°C	for 8000 h ³⁾ for 2000 h ³⁾ for 1000 h ³⁾
¹⁾ In the EEPROM, it is not allowed to program only one single address within a 'bank' in the memory. In case of programming one single address the complete bank has to be programmed ²⁾ Depends on the temperature profile of the application. Please contact TDK-Micronas for life time calculations. ³⁾ Time values are not cumulative							

4.7. Characteristics

at $T_J = -40\text{ °C}$ to $+170\text{ °C}$, $V_{SUP} = 4.5\text{ V}$ to 5.5 V , $GND = 0\text{ V}$, after programming and locking of the sensor, at Recommended Operating Conditions if not otherwise specified in the column "Conditions". Typical Characteristics for $T_J = 25\text{ °C}$ and $V_{SUP} = 5\text{ V}$.

Symbol	Parameter	Pin	Limit Values			Unit	Test Conditions
			Min.	Typ.	Max.		
I_{SUP}	Supply Current over Temperature Range	VSUP	–	7	11	mA	
	Resolution ¹⁾	OUT	–	12	–	bit	depends on PWM Period
$t_{r(O)}$	Response Time of Output ²⁾	OUT	–	1.5 2.5 4.5 8.5	1.8 3 5.4 10.2	ms	$f_{PWM} = 2\text{ kHz}$ $f_{PWM} = 1\text{ kHz}$ $f_{PWM} = 500\text{ Hz}$ $f_{PWM} = 250\text{ Hz}$
$t_{\Delta Vs}$	Wake-up time ²⁾	OUT	–	–	1.7	ms	$C_L = 10\text{ nF}$
V_{OUTL}	Output Low Voltage	OUT	–	0.5	–	V	$V_{SUP} = 5\text{ V}$, $I_{OUT} < 5\text{ mA}$
$OUT_{NOISErms}$	Output Noise RMS ²⁾	OUT	–	0.05	0.1	%	BARREL SHIFTER=3 Overall gain in signal path =1 External circuitry according to Fig. 5–1 with low-noise supply Related to 12 bit full scale
f_{PWM}	PWM Frequency ²⁾	OUT	1.7 0.85 0.425 0.213	2 1 0.5 0.25	2.3 1.15 0.575 0.288	kHz	Customer programmable
J_{PWM}	RMS PWM Jitter ²⁾	OUT	–	1	2	LSB ₁₂	$f_{PWM} = 1\text{ kHz}$
t_{rise}	Rise Time of Digital Output ²⁾	OUT	–	0.4	–	μs	R_L Pull-up = $1\text{ k}\Omega$, $C_L = 1\text{ nF}$
t_{fall}	Fall Time of Digital Output ²⁾	OUT	–	0.5	–	μs	R_L Pull-up = $1\text{ k}\Omega$, $C_L = 1\text{ nF}$
ROUT_DIG	On Resistance of Digital Pull-Up Driver ²⁾	OUT	–	100	200	Ω	Includes $25\text{ }\Omega$ series pull-up resistor and $50\text{ }\Omega$ pull-down
SOIC8 Package							
R_{thja}	Thermal Resistance Junction to Air	–	–	–	142	K/W	Determined with a 1s0p board
R_{thjc}	Junction to Case	–	–	–	88	K/W	Determined with a 1s1p board
		–	–	–	33	K/W	Determined with a 1s0p board
		–	–	–	22	K/W	Determined with a 1s1p board
TO92UT Package							
R_{thja}	Thermal Resistance Junction to Air	–	–	–	232	K/W	Determined with a 1s0p board
		–	–	–	136	K/W	Determined with a 2s2p board
R_{thjc}	Junction to Case	–	–	–	40	K/W	Determined with a 1s0p board
		–	–	–	36	K/W	Determined with a 2s2p board
¹⁾ Guaranteed by Design ²⁾ Characterized on small sample size, not tested.							

4.8. Overvoltage and Undervoltage Detection

at $T_J = -40\text{ °C}$ to $+170\text{ °C}$, Typical Characteristics for $T_J = 25\text{ °C}$, after programming and locking

Symbol	Parameter	Pin	Min.	Typ.	Max.	Unit	Test Conditions
$V_{SUP,UV}$	Undervoltage Detection Level	VSUP	3.3	3.9	4.3	V	
$V_{SUP,UVhyst}$	Undervoltage Detection Level Hysteresis ¹⁾	VSUP	–	200	–	mV	
$V_{SUP,OV}$	Overvoltage Detection Level	VSUP	5.6	6.2	6.9	V	
$V_{SUP,OVhyst}$	Overvoltage Detection Level Hysteresis ¹⁾	VSUP	–	225	–	mV	

¹⁾ Characterized on small sample size, not tested

4.9. Magnetic Characteristics

at $T_J = -40\text{ °C}$ to $+170\text{ °C}$, $V_{SUP} = 4.5\text{ V}$ to 5.5 V , $GND = 0\text{ V}$ after programming and locking, at Recommended Operating Conditions if not otherwise specified in the column "Conditions". Typical Characteristics for $T_J = 25\text{ °C}$ and $V_{SUP} = 5\text{ V}$.

Symbol	Parameter	Pin No.	Min.	Typ.	Max	Unit	Test Conditions
SENS	Magnetic Sensitivity	$\Delta DC / (2 \times RANGE_{ABS})$				%DC / mV ²⁾	Example: For Barrel_shifter=5 and $\Delta DC = 100\%$ $RANGE_{ABS} = 12\text{ mT}$ Sensitivity = $100\% / (2 \times 12\text{ mT}) = 4.2\%DC/mT$ max.
$RANGE_{ABS}$	Absolute Range of CFX Register (Magnetic Range) ¹⁾	–	6	–	200	mT	Programmable: See Table 3–2 for relation between barrel shifter and Magnetic Range.
B_{Offset}	Magnetic Offset ¹⁾	OUT	–0.4	0	0.4	mT	$B = 0\text{ mT}$, $I_{OUT} = 0\text{ mA}$, $T_J = 25\text{ °C}$, unadjusted sensor
$\Delta B_{Offset} / \Delta T$	Magnetic Offset Change due to T_J ¹⁾	OUT	–5	0	5	$\mu T/K$	$B = 0\text{ mT}$, $I_{OUT} = 0\text{ mA}$ BARREL SHIFTER = 3 ($\pm 50\text{ mT}$)
ES	Error in Magnetic Sensitivity	OUT	–1	0	+1	%	TO92 package, $V_{SUP} = 5\text{ V}$, BARREL SHIFTER = 3 ($\pm 50\text{ mT}$) SOIC8 package, $V_{SUP} = 5\text{ V}$, BARREL SHIFTER = 3 ($\pm 50\text{ mT}$)

¹⁾ Characterized on small sample size, not tested
²⁾ DC = duty cycle

4.9.1. Definition of Sensitivity Error ES

ES is the maximum of the absolute value of the quotient of the normalized measured value¹ over the normalized ideal linear value² minus 1:

$$ES = \max\left(\text{abs}\left(\frac{\text{meas}}{\text{ideal}} - 1\right)\right)_{[T_{\min}, T_{\max}]}$$

In the below example, the maximum error occurs at -10 °C:

$$ES = \frac{1.001}{0.993} - 1 = 0.8\%$$

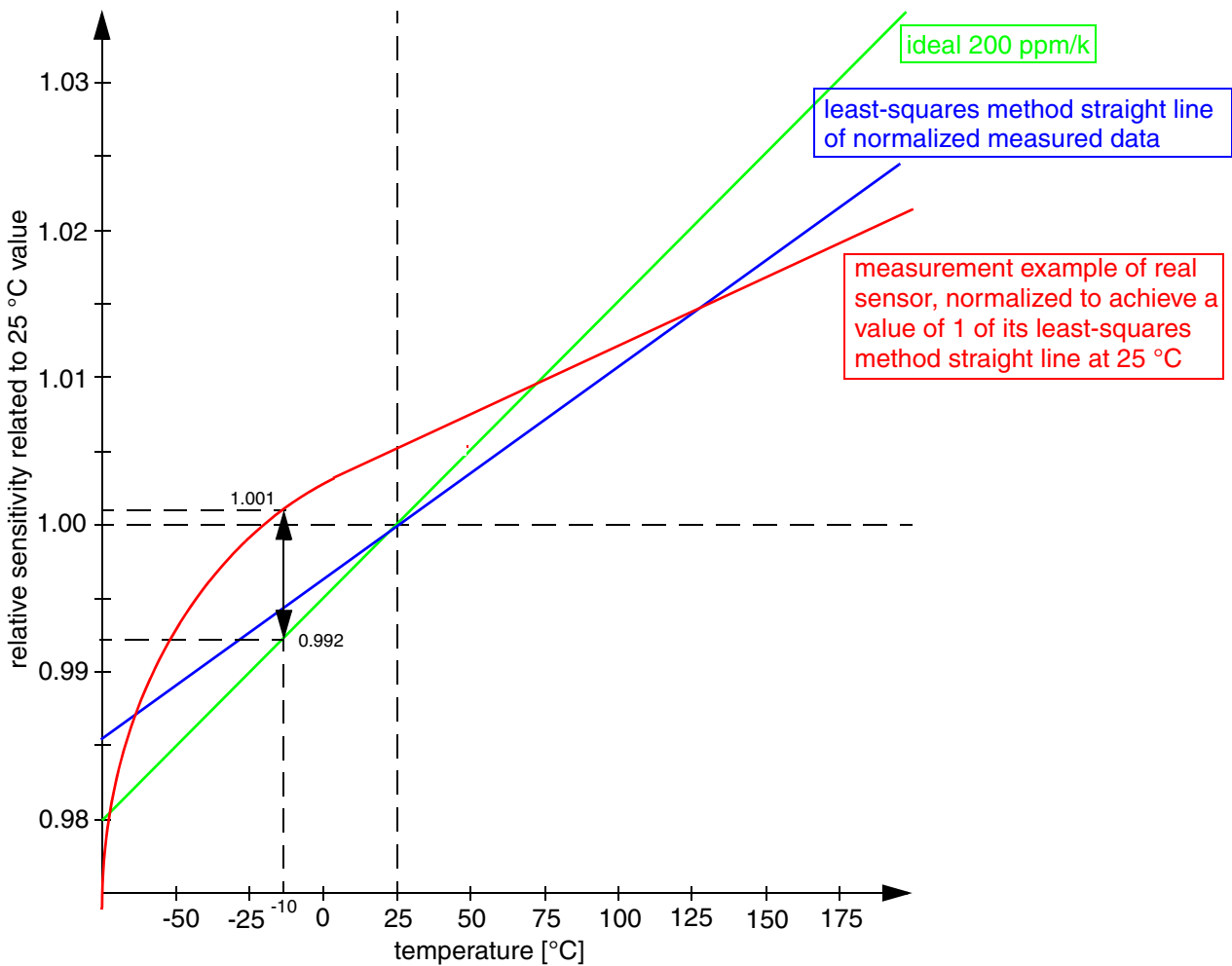

Fig. 4–8: ES definition example

1. normalized to achieve a least-squares method straight-line that has a value of 1 at 25 °C
2. normalized to achieve a value of 1 at 25 °C

5. Application Notes

5.1. Application Circuit

For EMC protection, it is recommended to connect one ceramic 47 nF capacitor between ground and the supply voltage pin, and a 180 pF capacitor between ground and the output pin.

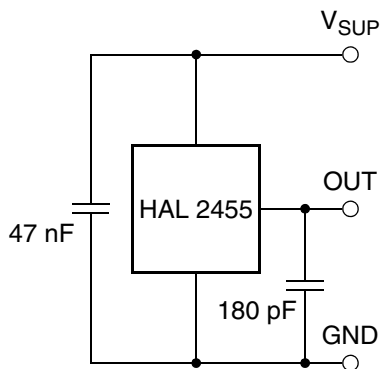

Fig. 5–1: Recommended application circuit

5.2. Measurement of a PWM Output Signal of HAL 2455

In case of the PWM output, the magnetic field information is coded in the duty cycle of the PWM signal. The duty cycle is defined as the ratio between the high time “s” and the period “d” of the PWM signal (see Fig. 5–2).

Note The PWM signal is updated with the rising edge. Hence, for signal evaluation, the trigger-level must be the rising edge of the PWM signal.

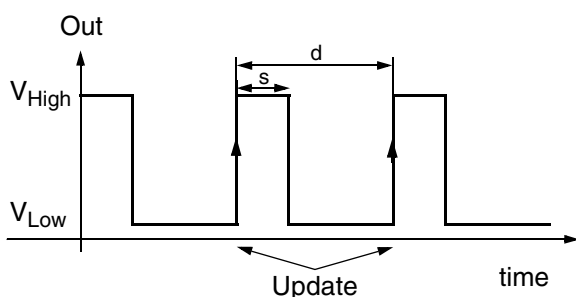

Fig. 5–2: Definition of PWM signal

5.3. Use of two HAL 2455 in Parallel

Two different HAL 2455 sensors which are operated in parallel to the same supply and ground line can be programmed individually as the communication with the sensors is done via their output pins.

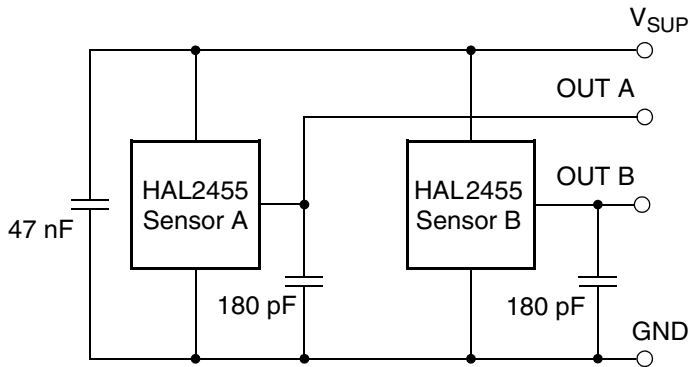

Fig. 5–3: Parallel operation of two HAL 2455

5.4. Ambient Temperature

Due to the internal power dissipation, the temperature on the silicon chip (junction temperature T_J) is higher than the temperature outside the package (ambient temperature T_A).

$$T_J = T_A + \Delta T$$

At static conditions and continuous operation, the following equation applies:

$$\Delta T = I_{SUP} * V_{SUP} * R_{thjX}$$

The X represents junction-to-air or junction-to-case.

In order to estimate the temperature difference ΔT between the junction and the respective reference (e.g. air, case, or solder point) use the max. parameters for I_{SUP} , R_{thjX} , and the max. value for V_{SUP} from the application.

The following example shows the result for junction-to-air conditions. $V_{SUP} = 5.5$ V, $R_{thja} = 250$ K/W and $I_{SUP} = 10$ mA the temperature difference $\Delta T = 13.75$ K.

The junction temperature T_J is specified. The maximum ambient temperature T_{Amax} can be estimated as:

$$T_{Amax} = T_{Jmax} - \Delta T$$

Please contact TDK-Micronas for the detailed investigation reports with the EMC and ESD results.

5.5. EMC and ESD

Please contact TDK-Micronas for the detailed investigation reports with the EMC and ESD results.

6. Programming of the Sensor

HAL 2455 features two different customer modes. In **Application Mode** the sensor provides a PWM output signal. In **Programming Mode** it is possible to change the register settings of the sensor.

After power-up the sensor is always operating in the **Application Mode**. It is switched to the **Programming Mode** by a pulse on the sensor output pin.

6.1. Programming Interface

In Programming Mode the sensor is addressed by modulating a serial telegram on the sensors output pin. The sensor answers with a modulation of the output voltage.

A logical “0” is coded as no level change within the bit time. A logical “1” is coded as a level change of typically 50% of the bit time. After each bit, a level change occurs (see Fig. 6–1).

The serial telegram is used to transmit the EEPROM content, error codes and digital values of the angle information from and to the sensor.

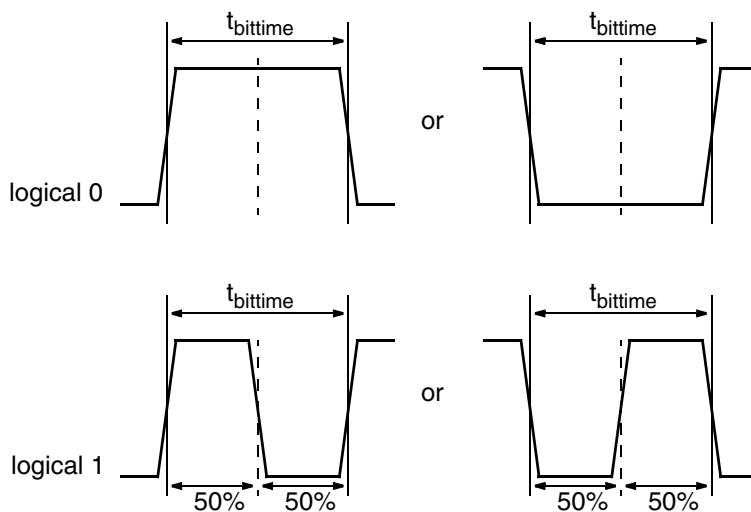

Fig. 6–1: Definition of logical 0 and 1 bit

A description of the communication protocol and the programming of the sensor is available in a separate document (Application Note: HAL 24xy Programming Guide).

Table 6–1: Telegram parameters (All voltages are referenced to GND.)

Symbol	Parameter	Pin No.	Limit Values			Unit	Test Conditions
			Min.	Typ.	Max.		
V _{OUTL}	Voltage for Output Low Level during Programming through Sensor Output Pin	OUT	0	–	0.2*V _{SUP}	V	
			0	–	1.0	V	for V _{SUP} = 5 V
V _{OUTH}	Voltage for Output High Level during Programming through Sensor Output Pin	OUT	0.8*V _{SUP}	–	V _{SUP}	V	
			4.0	–	5.0	V	for V _{SUP} = 5 V
V _{SUPProgram}	V _{SUP} Voltage for EEPROM programming (after PROG and ERASE)	1	5.7	6.0	6.5	V	Supply voltage for bidirectional communication via output pin.
t _{bittime}	Biphase Bit Time	3	900	1000	1100	µs	
	Slew rate	3	–	2	–	V/ µs	

6.2. Programming Environment and Tools

For the programming of HAL 2455 it is possible to use the Micronas tool kit (TDK-MSP V1.x & LabVIEW™ Programming Environment) or the USB kit in order to ease the product development. The details of programming sequences are also available at service.micronas.com.

6.3. Programming Information

For reliability in service, it is mandatory to set the LOCK bit to one and the POUT bit to zero after final adjustment and programming of HAL 2455.

The success of the LOCK process must be checked by reading the status of the LOCK bit after locking and by a negative communication test after a power on reset.

It is also mandatory to check the acknowledge (first and second) of the sensor or to read/check the status of the PROG_DIAGNOSIS register after each write and store sequence to verify if the programming of the sensor was successful. Please check HAL 242x Programming Guide for further details.

Electrostatic Discharges (ESD) may disturb the programming pulses. Please take precautions against ESD.

Note Please check also the “HAL 24xy Programming Guide”. It contains additional information and instructions about the programming of the devices.

7. Document History

1. Preliminary Data Sheet: "HAL 2455 High-Precision Programmable Linear Hall-Effect Sensor with PWM Output", July 8, 2014, Pd000215_001EN. First release of the Preliminary Data Sheet.
2. Preliminary Data Sheet: "HAL 2455 High-Precision Programmable Linear Hall-Effect Sensor with PWM Output", Sept. 19, 2014, PD000215_002EN. Second release of the Preliminary Data Sheet.

Major Changes:

- SOIC8 package drawing updated
- Absolute Maximum Ratings – Specification of ESD Protection for SOIC8 package

3. Data Sheet: "HAL 2455 High-Precision Programmable Linear Hall-Effect Sensor with PWM Output", Jan. 14, 2016, DSH000173_001EN. First release of the Data Sheet.

Major Changes:

- SOIC8 package drawing updated
- Corrected position A4 value for SOIC8 package
- Updated condition ($C_L=1$ nF) for rise time and fall time of digital output
- Characteristics: Supply Current over Temperature Range (I_{SUP}): values updated
- Assembly and storage information changed

4. Data Sheet: "HAL 2455 High-Precision Programmable Linear Hall-Effect Sensor with PWM Output", Sept. 9, 2020, DSH000173_002EN. Second release of the Data Sheet.

Major changes:

- SOIC8 package drawing updated
- TO92UT package and tape drawings updated
- Maximum Ratings: $T_{storage}$ added
- Magnetic Characteristics: new values for parameters SENS and $RANGE_{ABS}$

5. Data Sheet: "HAL 2455 High-Precision Programmable Linear Hall-Effect Sensor with PWM Output", May 20, 2021, DSH000173_003EN. Third release of the Data Sheet.

Major changes:

- Thermal resistance values for TO92UT package updated
- SOIC8-1 package drawing updated