

DC-EC AccuSens™ Series

General Purpose LVDT

The DC-EC AccuSens™ Series incorporates a unique monolithic chip combined with a computer-designed AC LVDT to achieve premium performance.

The ratiometric design of the monolithic circuitry compensates for power supply deviations for continuously stable operation. Unaffected by input variations, the transducer provides highly accurate, repeatable measurement.

Innovative manufacturing techniques further enhance the AccuSens operation and cost efficiency. Micro-miniature components used in the construction of each unit are selected for maximum stability.

Vacuum encapsulation of all elements produces an assembly tolerant to shock, vibration and other forms of physical abuse. Double magnetic shielding protects against stray electrical fields.

Features

- Linearity 0.25% of FS or better
- CE certified
- Integrated signal conditioning
- Rugged stainless steel construction
- Calibration certificates supplied with all models

Applications

- General

Options

- Metric thread core
- Captive core option for convenient installation
- Guided core
- Small diameter, low mass core



Specifications

Input Voltage	±15 VDC (nominal), ±25 mA
Operating Temperature Range	32°F to 160°F (0°C to 70°C)
Survival Temperature Range	-65°F to 200°F (-55°C to 95°C)
Null Voltage	0 VDC
Ripple	Less than 25 mV rms
Linearity	0.25% full range
Stability	0.125% full scale
Temperature—Coefficient of Scale Factor	0.04%/°F (0.08%/°C)
Shock Survival	250 g for 11 milliseconds
Vibration Tolerance	10 g up to 2 kHz
Coil Form Material	High density, glass-filled polymer
Housing Material	AISI 400 series stainless steel
Cable	4 conductor, 28 AWG, stranded copper with braided shield and polyurethane jacket, 1 meter
EMC	CE certified (The DC-EC series, when correctly installed, comply with the EMC Directive 89/336/EEC generic standards for residential commercial, light industrial and industrial environments.)
Output Impedance	Less than 1 ohm

Performance and Electrical Specifications¹

DC-EC Series Model Number	Nominal Linear Range		Scale Factor		Response
	inches	mm	V/inch	V/mm	-3 dB Hz
050 DC-EC	±0.050	±1.25	200.0	8.00	500
125 DC-EC	±0.125	±3.0	80.0	3.20	500
250 DC-EC	±0.250	±6.0	40.0	1.60	500
500 DC-EC	±0.500	±12.5	20.0	0.80	200
1000 DC-EC	±1.000	±25	10.0	0.40	200
2000 DC-EC	±2.000	±50	5.0	0.20	200
3000 DC-EC	±3.000	±75	3.3	0.13	200
5000 DC-EC	±5.000	±125	2.0	0.08	200
10000 DC-EC	±10.00	±250	1.0	0.04	200

¹All calibration is performed at room ambient temperature.

DC-EC models, when correctly installed, are CE certified to comply with the EMC Directive 89/336/EEC.



DC-EC Series LVDT
Monolithic chip circuitry
DC-Operated

How to Order

Specify the DC-EC Model followed by the desired option number(s) added together.

Ordering Example:

Model Number 050 DC-EC-200 is an DC-EC Series LVDT with a ± 0.050 " range (050 DC-EC), with the captive core option (200).

DC-EC Model Options

DC-EC Model	Options
050 DC-EC	Number Description
125 DC-EC	006 Metric Thread Core
250 DC-EC	010 Guided Core
500 DC-EC	020 Small Diameter, Low Mass Core ¹
1000 DC-EC	200 Captive Core ²
2000 DC-EC	¹ Consult factory for mass, dimensions and thread size.
3000 DC-EC	² Available on 050 DC-EC through 3000 DC-EC models only.
5000 DC-EC	
10000 DC-EC	

New Captive Core Option!

The DC-EC features a captive core design that greatly simplifies installation. The design utilizes a core rod and bearing assembly that is captured and guided within the LVDT providing low friction travel throughout the stroke length. The assembly incorporates two Delrin bearings on the core rod traveling through the stainless steel boreliner. A bronze bearing on the front end utilizes a self-aligning feature to accommodate lateral LVDT movement during operation. The core rod and bearing assembly are field replaceable. See page 71 for specifications.



Wiring

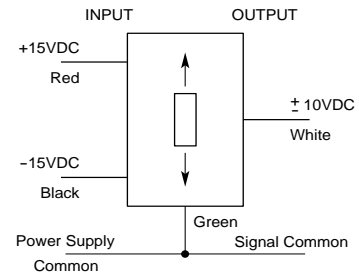

Block Diagram

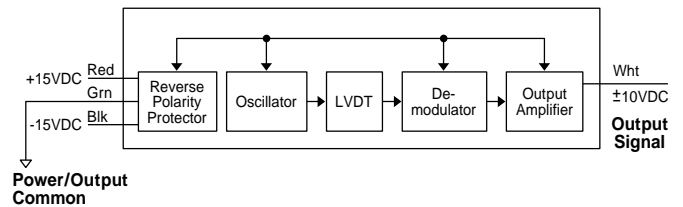

Dimensions in (mm)

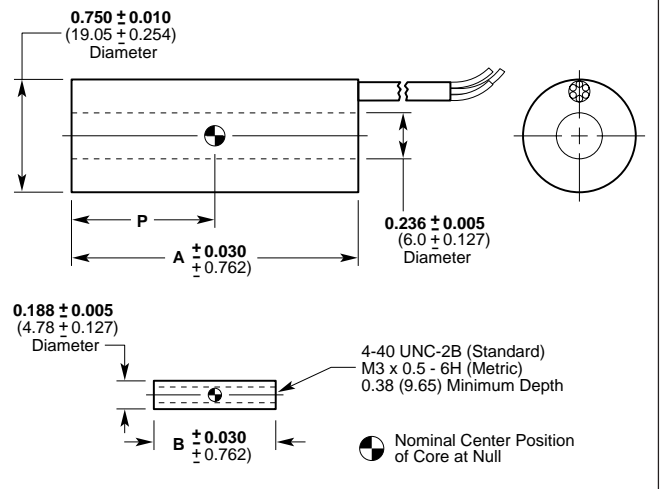

Mechanical Specifications

DC-EC Series Model Number	Weight				Dimensions					
	Body		Core		A (Body)		B (Core)		P	
	oz	gm	oz	gm	in	mm	in	mm	in	mm
050 DC-EC	2.19	62	0.07	2	2.10	53.5	0.75	19.1	0.50	12.7
125 DC-EC	2.44	69	0.11	3	2.93	74.5	1.25	31.8	0.93	23.6
250 DC-EC	2.58	73	0.18	5	3.80	96.5	2.00	50.8	1.35	34.3
500 DC-EC	2.93	82	0.28	8	5.49	139.5	3.00	76.0	2.20	55.9
1000 DC-EC	4.24	120	0.35	10	7.75	196.9	3.80	96.5	3.18	80.8
2000 DC-EC	5.47	155	0.46	13	11.12	282.5	5.30	135.0	4.88	134.6
3000 DC-EC	9.39	266	0.49	14	16.32	414.5	6.20	157.5	7.55	191.8
5000 DC-EC	11.47	325	0.60	17	20.15	511.8	6.20	157.5	9.53	242.0
10000 DC-EC	15.71	445	0.85	24	35.38	898.5	12.00	305.0	16.58	421.1



Captive Core Option

Lead Wire Models for DC-EC and DC-SE Series

Available for most models within the HCA, DC-EC, DS-SE, HCD and HCT Series

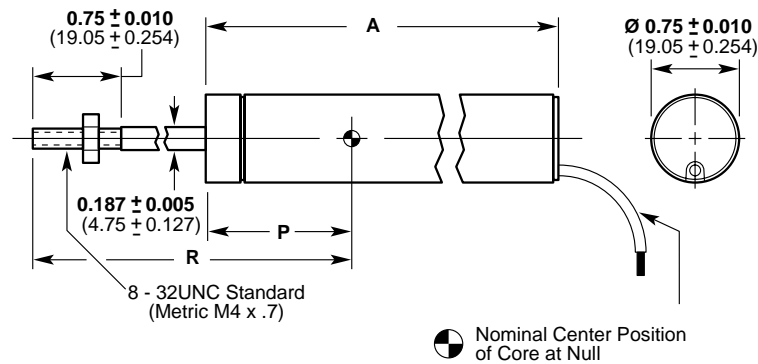

Mechanical Specifications

	Model Number	Linear Range		Weight Assembly		A		P		R	
		in	mm	oz	gm	in	mm	in	mm	in	mm
DC-EC Series (See Page 56)	050 DC-EC	±0.050	±1.25	2.97	84	2.48	63.0	0.84	21.3	3.78	98.0
	125 DC-EC	±0.125	±3.0	3.32	94	3.31	84.1	1.27	32.3	4.36	110.7
	250 DC-EC	±0.250	±6.0	3.53	100	4.18	84.1	1.69	42.9	4.85	123.2
	500 DC-EC	±0.500	±12.5	4.02	114	5.87	149.1	2.54	64.5	6.04	153.4
	1000 DC-EC	±1.000	±25	5.61	159	8.13	206.5	3.52	89.4	7.90	200.7
	2000 DC-EC	±2.000	±50	7.20	204	11.50	292.1	5.22	143.3	10.52	267.2
	3000 DC-EC	±3.000	±75	11.68	331	16.70	424.2	7.89	200.4	15.27	387.9
DC-SE Series (See Page 58)	100 DC-SE	0-0.100	0-2.5	1.52	43	3.85	97.8	0.85	21.6	3.69	93.7
	250 DC-SE	0-0.250	0-6.0	4.09	116	4.70	119.4	1.27	32.3	4.28	108.7
	500 DC-SE	0-0.500	0-12.5	4.34	123	5.54	140.7	1.69	42.9	4.75	120.7
	1000 DC-SE	0-1.000	0-25	5.51	156	7.23	183.6	2.54	64.5	6.04	153.4
	2000 DC-SE	0-2.000	0-50	7.62	216	9.21	233.9	3.53	89.7	7.90	200.7
	4000 DC-SE	0-4.000	0-100	10.13	287	12.59	319.8	5.22	132.6	10.52	267.2
	6000 DC-SE	0-6.000	0-150	12.92	366	17.64	448.1	7.90	200.7	15.27	387.9

LVDT Accessories

LVDT Mounting Blocks

Frequently, LVDT installations require a convenient method to mount the units. Ready-made mounting blocks are available for all LVDT Series (except XS-B). Constructed of reinforced phenolic and other nonconductive materials with a low-temperature coefficient of expansion, mounting blocks are a convenient, inexpensive and fast solution for LVDT installation.



To Order: use the chart below to specify the part number for the appropriate LVDT Series.

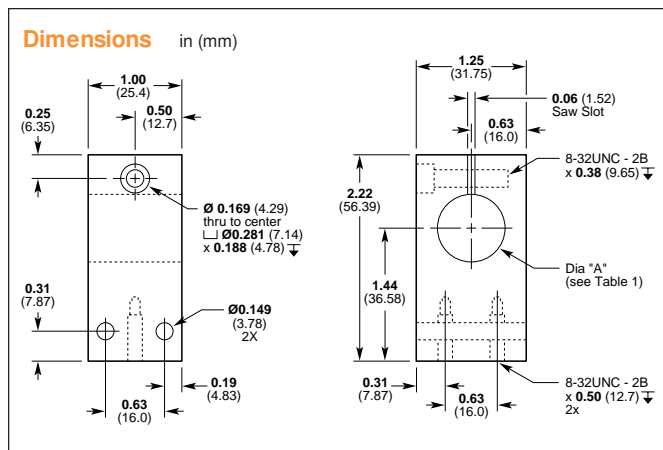

LVDT Mounting Blocks

Part Number	Use with LVDT Series	Dim. A Diameter	LVDT Diameter
04560950-000	E	0.77	0.750
04560952-000	HR	0.83	0.812
04560953-000	M	0.33	8 mm
04560954-000	MHR	0.39	0.375
04560956-000	M-12	0.49	12 mm

MS-Type Connector Cables

Consult factory for price and availability of adaptor cables for LVDTs and signal conditioners.

Core Connecting Rods

LVDT installations require a connecting rod between the LVDT core and the object whose motion is being measured. These connecting rods are fabricated from non-magnetic stainless steel to prevent distortion of the LVDT's magnetic field.



Manufactured from AISI 300 Series stainless steel, core connecting rods are threaded end to end. (Consult factory for available lengths and sizes.)

To Order: Specify CCR-(Length)-(LVDT Series)-(S for standard thread or M for metric thread). For example, to order a 4" rod to go with an MHR Series LVDT equipped with the optional metric thread core, specify: CCR-4-MHR-M

PSD 4-15 DC LVDT Power Supply

The PSD 4-15 DC LVDT power supply is designed to work with all of Schaevitz® DC powered LVDTs. The module will operate on either a 115 VAC or 230 VAC input at 47 to 63 Hz. The PSD 4-15 provides the necessary ±15 VDC excitation to operate as many as four DC-EC or HCD Series LVDTs, as well as GCD Series gage heads or DC powered Schaevitz® RVDTs (see rotary section) or pressure transducers (see pressure section) that require a ±15 VDC input. The rugged, compact design can be chassis mounted and features a DIN standard rail mount for secure installation in most industrial environments. In addition, the PSD 4-15 is UL, VDE and cUL approved and CE certified.



General Specifications

Input Voltage	115/230 VAC ±10%
Input Frequency	47 to 63 Hz
Input Current	0.1 A (max)
Output Voltage	±15 VDC ±0.05%
Output Current	100 mA continuous
Ripple	< 5mV. pp.
Noise	< 5mV. pp.
Overload Protection	Continuous
Overall Dimensions	2.00 x 4.31 x 0.90 inches; (51 x 110 x 23 mm)
Operating Temperature	-25°C to 70°C