

# 19 Output Differential Buffer for PCIe Gen2 and QPI

9DB1904B

## Description

The **9DB1904** is electrically compatible to the Intel DB1900GS Differential Buffer Specification. This buffer provides 19 output clocks for PCI-Express Gen2 or Intel QPI 6.4GT/s applications. A differential clock from a CK410B+ main clock generator, such as the ICS932S421 drives the **9DB1904**. The **9DB1904** can provide outputs up to 400MHz in Bypass Mode.

## Recommended Application

19 Output Differential Buffer for PCIe Gen2 and QPI

## Key Specifications

- DIF output cycle-to-cycle jitter < 50ps
- DIF output-to-output skew < 150ps across all outputs

## Features/Benefits

- Power up default is all outputs in 1:1 mode/No SMBus programming
- Spread spectrum compatible/EMI reductions
- Supports output frequencies up to 400 MHz in bypass mode/flexible fanout buffer
- 8 Selectable SMBus addresses/no SMBus segmentation required
- SMBus address determines PLL or Bypass mode/pin savings
- Dedicated VDDA and CKPWRGD\_PD# pins/easy board design

### Functionality at Power Up (PLL Mode)

100M_133M#	CLK_IN MHz	DIF_(18:0) MHz
1	100MHz	CLK_IN
0	133MHz	CLK_IN

### Power Down Functionality

INPUTS		OUTPUTS	PLL State
CKPWRGD_PD#	CLK_IN/CLK_IN#	DIF/DIF#	
1	Running	Running	ON
0	X	Hi-Z	OFF

## Pin Configuration

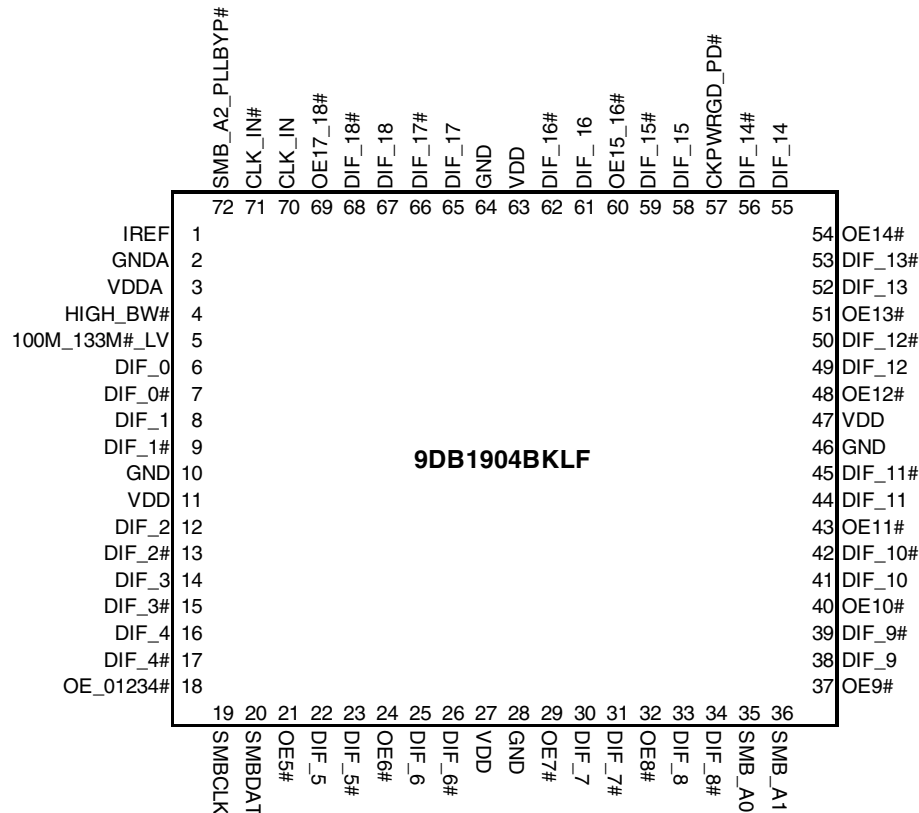

## Pin Description

PIN #	PIN NAME	PIN TYPE	DESCRIPTION
1	IREF	OUT	This pin establishes the reference for the differential current-mode output pairs. It requires a fixed precision resistor to ground. 475ohm is the standard value for 100ohm differential impedance. Other impedances require different values. See data sheet.
2	GNDA	PWR	Ground pin for the PLL core.
3	VDDA	PWR	3.3V power for the PLL core.
4	HIGH_BW#	IN	3.3V input for selecting PLL Band Width 0 = High, 1= Low
5	100M_133M#_LV	IN	Low Threshold Input to select operating frequency. See Functionality Table for Definition
6	DIF_0	OUT	0.7V differential true clock output
7	DIF_0#	OUT	0.7V differential Complementary clock output
8	DIF_1	OUT	0.7V differential true clock output
9	DIF_1#	OUT	0.7V differential Complementary clock output
10	GND	PWR	Ground pin.
11	VDD	PWR	Power supply, nominal 3.3V
12	DIF_2	OUT	0.7V differential true clock output
13	DIF_2#	OUT	0.7V differential Complementary clock output
14	DIF_3	OUT	0.7V differential true clock output
15	DIF_3#	OUT	0.7V differential Complementary clock output
16	DIF_4	OUT	0.7V differential true clock output
17	DIF_4#	OUT	0.7V differential Complementary clock output
18	OE_01234#	IN	Active low input for enabling DIF pairs 0, 1, 2, 3 and 4. 1 =disable outputs, 0 = enable outputs
19	SMBCLK	IN	Clock pin of SMBUS circuitry, 5V tolerant
20	SMBDAT	I/O	Data pin of SMBUS circuitry, 5V tolerant
21	OE5#	IN	Active low input for enabling DIF pair 5. 1 =disable outputs, 0 = enable outputs
22	DIF_5	OUT	0.7V differential true clock output
23	DIF_5#	OUT	0.7V differential Complementary clock output
24	OE6#	IN	Active low input for enabling DIF pair 6. 1 =disable outputs, 0 = enable outputs
25	DIF_6	OUT	0.7V differential true clock output
26	DIF_6#	OUT	0.7V differential Complementary clock output
27	VDD	PWR	Power supply, nominal 3.3V
28	GND	PWR	Ground pin.
29	OE7#	IN	Active low input for enabling DIF pair 7. 1 =disable outputs, 0 = enable outputs
30	DIF_7	OUT	0.7V differential true clock output
31	DIF_7#	OUT	0.7V differential Complementary clock output
32	OE8#	IN	Active low input for enabling DIF pair 8. 1 =disable outputs, 0 = enable outputs
33	DIF_8	OUT	0.7V differential true clock output
34	DIF_8#	OUT	0.7V differential Complementary clock output
35	SMB_A0	IN	SMBus address bit 0 (LSB)
36	SMB_A1	IN	SMBus address bit 1

**Pin Description (continued)**

PIN #	PIN NAME	PIN TYPE	DESCRIPTION
37	OE9#	IN	Active low input for enabling DIF pair 9. 1 =disable outputs, 0 = enable outputs
38	DIF_9	OUT	0.7V differential true clock output
39	DIF_9#	OUT	0.7V differential Complementary clock output
40	OE10#	IN	Active low input for enabling DIF pair 10. 1 =disable outputs, 0 = enable outputs
41	DIF_10	OUT	0.7V differential true clock output
42	DIF_10#	OUT	0.7V differential Complementary clock output
43	OE11#	IN	Active low input for enabling DIF pair 11. 1 =disable outputs, 0 = enable outputs
44	DIF_11	OUT	0.7V differential true clock output
45	DIF_11#	OUT	0.7V differential Complementary clock output
46	GND	PWR	Ground pin.
47	VDD	PWR	Power supply, nominal 3.3V
48	OE12#	IN	Active low input for enabling DIF pair 12. 1 =disable outputs, 0 = enable outputs
49	DIF_12	OUT	0.7V differential true clock output
50	DIF_12#	OUT	0.7V differential Complementary clock output
51	OE13#	IN	Active low input for enabling DIF pair 13. 1 =disable outputs, 0 = enable outputs
52	DIF_13	OUT	0.7V differential true clock output
53	DIF_13#	OUT	0.7V differential Complementary clock output
54	OE14#	IN	Active low input for enabling DIF pair 14. 1 =disable outputs, 0 = enable outputs
55	DIF_14	OUT	0.7V differential true clock output
56	DIF_14#	OUT	0.7V differential Complementary clock output
57	CKPWRGD_PD#	IN	3.3V Input notifies device to sample latched inputs and start up on first high assertion, or exit Power Down Mode on subsequent assertions. Low enters Power Down Mode.
58	DIF_15	OUT	0.7V differential true clock output
59	DIF_15#	OUT	0.7V differential Complementary clock output
60	OE15_16#	IN	Active low input for enabling DIF pairs 15 and 16. 1 =disable outputs, 0 = enable outputs
61	DIF_16	OUT	0.7V differential true clock output
62	DIF_16#	OUT	0.7V differential Complementary clock output
63	VDD	PWR	Power supply, nominal 3.3V
64	GND	PWR	Ground pin.
65	DIF_17	OUT	0.7V differential true clock output
66	DIF_17#	OUT	0.7V differential Complementary clock output
67	DIF_18	OUT	0.7V differential true clock output
68	DIF_18#	OUT	0.7V differential Complementary clock output
69	OE17_18#	IN	Active low input for enabling DIF pairs 17 and 18. 1 =disable outputs, 0 = enable outputs
70	CLK_IN	IN	True Input for differential reference clock.
71	CLK_IN#	IN	Complementary Input for differential reference clock.
72	SMB_A2_PLLBYP#	IN	SMBus address bit 2. When Low, the part operates as a fanout buffer with the PLL bypassed. When High, the part operates as a zero-delay buffer (ZDB) with the PLL operating. 0 = fanout mode (PLL bypassed), 1 = ZDB mode (PLL used)

### Functional Block Diagram

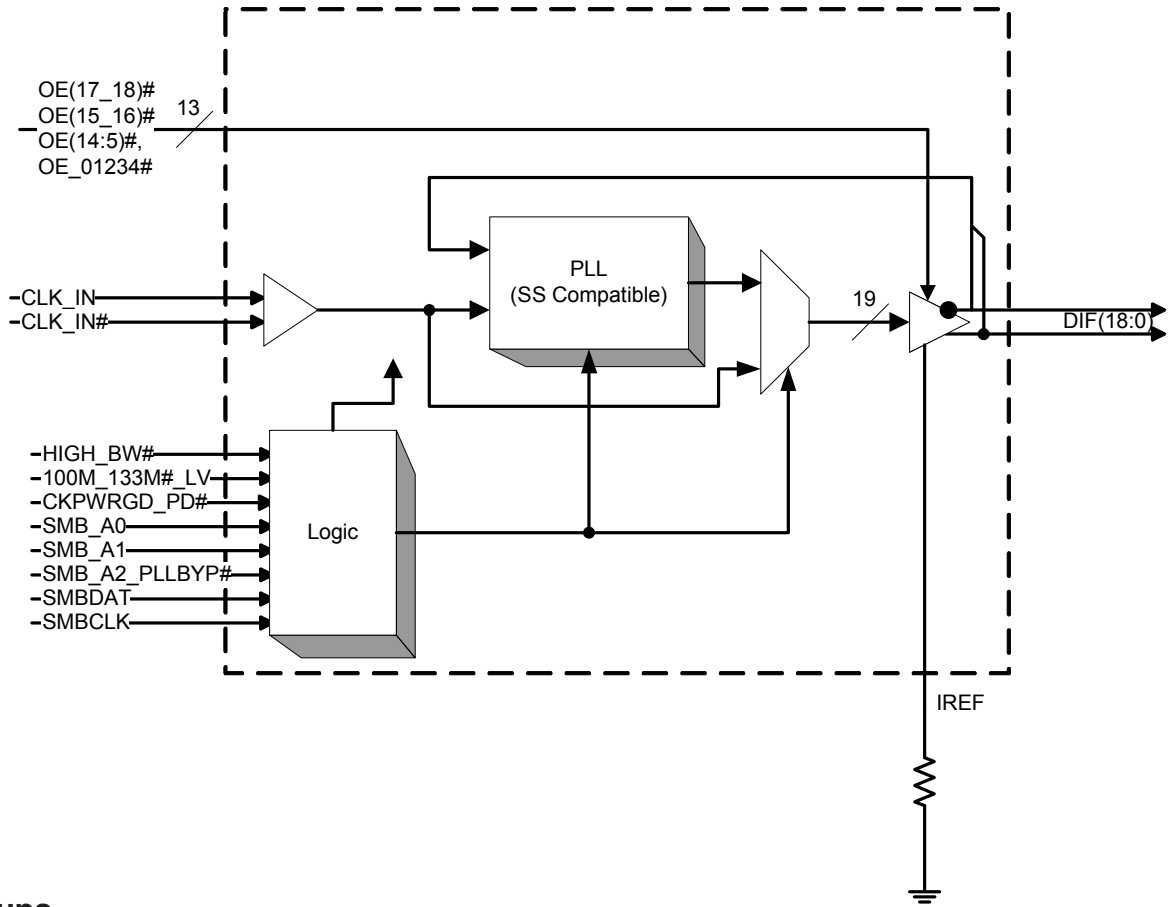

### Power Groups

Pin Number		Description
VDD	GND	
3	2	PLL, Analog
11,27,47,63	10,28,46,64	DIF clocks

### 9DB1904 Frequency Selects for PLL Mode

Byte 9, bit 2 100M_133M#_LV	Byte9, bit 1 FSB	Byte 9, bit 0 FSA	CLK_IN MHz	DIF Outputs MHz	Notes
1	0	1	100.00	100.00	1
0	0	1	133.33	133.33	2

#### Notes:FS\_A\_410 = 1

1. Powerup Default for 100M\_133M# = 1
2. Powerup Default for 100M\_133M# = 0

### Electrical Characteristics - Absolute Maximum Ratings

PARAMETER	SYMBOL	CONDITIONS	MIN	TYP	MAX	UNITS	NOTES
3.3V Core Supply Voltage	VDDA				4.6	V	1,2
3.3V Logic Supply Voltage	VDD				4.6	V	1,2
Input Low Voltage	V <sub>IL</sub>		GND-0.5			V	1
Input High Voltage	V <sub>IH</sub>	Except for SMBus interface			V <sub>DD</sub> +0.5V	V	1
Input High Voltage	V <sub>IHSMB</sub>	SMBus clock and data pins			5.5V	V	1
Storage Temperature	T <sub>s</sub>		-65		150	°C	1
Junction Temperature	T <sub>j</sub>				125	°C	1
Input ESD protection	ESD prot	Human Body Model	2000			V	1

<sup>1</sup>Guaranteed by design and characterization, not 100% tested in production.

<sup>2</sup>Operation under these conditions is neither implied nor guaranteed.

### Electrical Characteristics - Clock Input Parameters

TA = T<sub>COM</sub>; Supply Voltage VDD/VDDA = 3.3 V +/-5%, See Test Loads for Loading Conditions

PARAMETER	SYMBOL	CONDITIONS	MIN	TYP	MAX	UNITS	NOTES
Input High Voltage - DIF_IN	V <sub>IHDIF</sub>	Differential inputs (single-ended measurement)	600	800	1150	mV	1
Input Low Voltage - DIF_IN	V <sub>ILDIF</sub>	Differential inputs (single-ended measurement)	V <sub>SS</sub> - 300	0	300	mV	1
Input Common Mode Voltage - DIF_IN	V <sub>COM</sub>	Common Mode Input Voltage	300		1000	mV	1
Input Amplitude - DIF_IN	V <sub>SWING</sub>	Peak to Peak value	300		1450	mV	1
Input Slew Rate - DIF_IN	dv/dt	Measured differentially	0.4		8	V/ns	1,2
Input Leakage Current	I <sub>IN</sub>	V <sub>IN</sub> = V <sub>DD</sub> , V <sub>IN</sub> = GND	-5		5	uA	1
Input Duty Cycle	d <sub>tin</sub>	Measurement from differential waveform	45		55	%	1, 3
Input Jitter - Cycle to Cycle	J <sub>DIFIN</sub>	Differential Measurement	0		125	ps	1

<sup>1</sup> Guaranteed by design and characterization, not 100% tested in production.

<sup>2</sup>Slew rate measured through +/-75mV window centered around differential zero

<sup>3</sup> Input duty cycle will directly impact output duty cycle in bypass mode. It has no impact in PLL mode.

### Electrical Characteristics - Current Consumption

TA = T<sub>COM</sub>; Supply Voltage VDD/VDDA = 3.3 V +/-5%, See Test Loads for Loading Conditions

PARAMETER	SYMBOL	CONDITIONS	MIN	TYP	MAX	UNITS	NOTES
Operating Supply Current	I <sub>DD3.3OP</sub>	VDD, All outputs active @100MHz		425	450	mA	1
	I <sub>DD3.3AOP</sub>	VDDA, All outputs active @100MHz		35	45	mA	1
Powerdown Current	I <sub>DD3.3PD</sub>	VDD		20	25	mA	1
	I <sub>DD3.3APD</sub>	VDDA		12	15	mA	1

<sup>1</sup>Guaranteed by design and characterization, not 100% tested in production. Zo = 100Ω

**Electrical Characteristics - Input/Supply/Common Parameters**

TA = T<sub>COM</sub>; Supply Voltage VDD/VDDA = 3.3 V +/-5%, See Test Loads for Loading Conditions

PARAMETER	SYMBOL	CONDITIONS	MIN	TYP	MAX	UNITS	NOTES
Ambient Operating Temperature	T <sub>COM</sub>	Commercial range	0		70	°C	1
Input High Voltage	V <sub>IH</sub>	Single-ended inputs, except SMBus, low threshold and tri-level inputs	2		V <sub>DD</sub> + 0.3	V	1
Input Low Voltage	V <sub>IL</sub>	Single-ended inputs, except SMBus, low threshold and tri-level inputs	GND - 0.3		0.8	V	1
Low Threshold Input-High Voltage	V <sub>IH_FS</sub>	3.3 V +/-5%, Applies to 100M_133M#_LV pin	0.7		V <sub>DD</sub> + 0.3	V	1
Low Threshold Input-Low Voltage	V <sub>IL_FS</sub>	3.3 V +/-5%, Applies to 100M_133M#_LV pin	V <sub>SS</sub> - 0.3		0.35	V	1
Input Current	I <sub>IN</sub>	Single-ended inputs, V <sub>IN</sub> = GND, V <sub>IN</sub> = VDD	-5		5	uA	1
	I <sub>INP</sub>	Single-ended inputs V <sub>IN</sub> = 0 V; Inputs with internal pull-up resistors V <sub>IN</sub> = VDD; Inputs with internal pull-down resistors	-200		200	uA	1
Input Frequency	F <sub>ibyp</sub>	V <sub>DD</sub> = 3.3 V, Bypass mode	33		400	MHz	2
	F <sub>ipll</sub>	V <sub>DD</sub> = 3.3 V, 100MHz PLL mode	90	100.00	110	MHz	2
	F <sub>ipll</sub>	V <sub>DD</sub> = 3.3 V, 133.33MHz PLL mode	120	133.33	147	MHz	2
Pin Inductance	L <sub>pin</sub>				7	nH	1
Capacitance	C <sub>IN</sub>	Logic Inputs, except DIF_IN	1.5		5	pF	1
	C <sub>INDIF_IN</sub>	DIF_IN differential clock inputs	1.5		2.7	pF	1,4
	C <sub>OUT</sub>	Output pin capacitance			6	pF	1
Clk Stabilization	T <sub>STAB</sub>	From V <sub>DD</sub> Power-Up and after input clock stabilization or de-assertion of PD# to 1st clock			1.8	ms	1,2
Input SS Modulation Frequency	f <sub>MODIN</sub>	Allowable Frequency (Triangular Modulation)	30		33	kHz	1
OE# Latency	t <sub>LATOE#</sub>	DIF start after OE# assertion DIF stop after OE# deassertion	4		12	clocks	1,3
Tdrive_PD#	t <sub>DRVPD</sub>	DIF output enable after PD# de-assertion			300	us	1,3
Tfall	t <sub>F</sub>	Fall time of control inputs			5	ns	1,2
Trise	t <sub>R</sub>	Rise time of control inputs			5	ns	1,2
SMBus Input Low Voltage	V <sub>ILSMB</sub>				0.8	V	1
SMBus Input High Voltage	V <sub>IHSMB</sub>		2.1		V <sub>DD</sub> SMB	V	1
SMBus Output Low Voltage	V <sub>OLSMB</sub>	@ I <sub>PULLUP</sub>			0.4	V	1
SMBus Sink Current	I <sub>PULLUP</sub>	@ V <sub>OL</sub>	4			mA	1
Nominal Bus Voltage	V <sub>DD</sub> SMB	3V to 5V +/- 10%	2.7		5.5	V	1
SCLK/SDATA Rise Time	t <sub>RSMB</sub>	(Max VIL - 0.15) to (Min VIH + 0.15)			1000	ns	1
SCLK/SDATA Fall Time	t <sub>FSMB</sub>	(Min VIH + 0.15) to (Max VIL - 0.15)			300	ns	1
SMBus Operating Frequency	f <sub>MAXSMB</sub>	Maximum SMBus operating frequency			100	kHz	1,5

<sup>1</sup>Guaranteed by design and characterization, not 100% tested in production.

<sup>2</sup>Control input must be monotonic from 20% to 80% of input swing.

<sup>3</sup>Time from deassertion until outputs are >200 mV

<sup>4</sup>DIF\_IN input

<sup>5</sup>The differential input clock must be running for the SMBus to be active

**Electrical Characteristics - DIF 0.7V Current Mode Differential Outputs**

TA = T<sub>COM</sub>; Supply Voltage VDD/VDDA = 3.3 V +/-5%, See Test Loads for Loading Conditions

PARAMETER	SYMBOL	CONDITIONS	MIN	TYP	MAX	UNITS	NOTES
Slew rate	Trf	Scope averaging on	1	2	4	V/ns	1, 2, 3
Slew rate matching	ΔTrf	Slew rate matching, Scope averaging on		12.6	20	%	1, 2, 4
Voltage High	VHigh	Statistical measurement on single-ended signal using oscilloscope math function. (Scope averaging on)	660	797	850	mV	1
Voltage Low	VLow		-150	39	150		1
Max Voltage	Vmax	Measurement on single ended signal using absolute value. (Scope averaging off)		857	1150	mV	1
Min Voltage	Vmin		-300	7			1
Vswing	Vswing	Scope averaging off	300	1510		mV	1, 2
Crossing Voltage (abs)	Vcross_abs	Scope averaging off	250	378	550	mV	1, 5
Crossing Voltage (var)	Δ-Vcross	Scope averaging off		57	140	mV	1, 6

<sup>1</sup>Guaranteed by design and characterization, not 100% tested in production. IREF = VDD/(3xR<sub>R</sub>). For R<sub>R</sub> = 475Ω (1%), I<sub>REF</sub> = 2.32mA.

I<sub>OH</sub> = 6 x I<sub>REF</sub> and V<sub>OH</sub> = 0.7V @ Z<sub>O</sub>=50Ω (100Ω differential impedance).

<sup>2</sup> Measured from differential waveform

<sup>3</sup> Slew rate is measured through the Vswing voltage range centered around differential 0V. This results in a +/-150mV window around differential 0V.

<sup>4</sup> Matching applies to rising edge rate of Clock / falling edge rate of Clock#. It is measured in a +/-75mV window centered on the average cross point where Clock rising meets Clock# falling. The median cross point is used to calculate the voltage thresholds the oscilloscope uses for the edge rate calculations.

<sup>5</sup> Vcross is defined as voltage where Clock = Clock# measured on a component test board and only applies to the differential rising edge (i.e. Clock rising and Clock# falling).

<sup>6</sup> The total variation of all Vcross measurements in any particular system. Note that this is a subset of V<sub>cross\_min</sub>/max (V<sub>cross</sub> absolute) allowed. The intent is to limit Vcross induced modulation by setting V<sub>cross\_delta</sub> to be smaller than V<sub>cross</sub> absolute.

**9DBxxx Differential Test Loads**

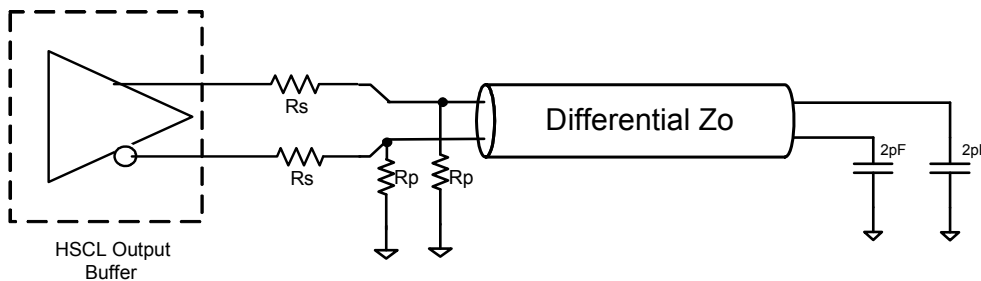

**Differential Output Termination Table**

DIF Zo (Ω)	Iref (Ω)	Rs (Ω)	Rp (Ω)
100	475	33	50
85	412	27	43.2

**Electrical Characteristics - Output Duty Cycle, Jitter, Skew and PLL Characteristics**

TA = T<sub>COM</sub>, Supply Voltage VDD = 3.3 V +/-5%

PARAMETER	SYMBOL	CONDITIONS	MIN	TYP	MAX	UNITS	NOTES
PLL Bandwidth	BW	-3dB point in High BW Mode	2	3	4	MHz	1
		-3dB point in Low BW Mode	0.7	1	1.4	MHz	1
PLL Jitter Peaking	t <sub>JPEAK</sub>	Peak Pass band Gain		1.4	2	dB	1
Duty Cycle	t <sub>DC</sub>	Measured differentially, PLL Mode	45	49.5	55	%	1,2
Duty Cycle Distortion	t <sub>DCD</sub>	Measured differentially, Bypass Mode @100MHz	-2	1	2	%	1,2,5
Skew, Input to Output	t <sub>pdBYP</sub>	Bypass Mode, nominal value @ 25°C, 3.3V, V <sub>T</sub> = 50%	2500	3700	4500	ps	1,2,4
	t <sub>pdPLL</sub>	PLL Mode, nominal value @ 25°C, 3.3V, V <sub>T</sub> = 50%	100	300	500	ps	1,2,3
DIF_IN, DIF [x:0]	Δt <sub>pd_BYP</sub>	Input-to-Output Skew Variation in Bypass mode (over specified voltage / temperature operating ranges)		1500 <sup>1</sup>	1600 <sup>1</sup>	ps	1,2,4,6,7,8,9,13
DIF_IN, DIF [x:0]	Δt <sub>pd_PLL</sub>	Input-to-Output Skew Variation in PLL mode (over specified voltage / temperature operating ranges)		1250 <sup>1</sup>	1350 <sup>1</sup>	ps	1,2,3,6,7,8,9,13
DIF[X:0]	t <sub>JPH</sub>	Differential Phase Jitter (RMS Value)		2	10	ps	1,7,10
DIF[X:0]	t <sub>SSERROR</sub>	Differential Spread Spectrum Tracking Error (peak to peak)		40	80	ps	1,7,12
Skew, Output to Output	t <sub>sk3</sub>	V <sub>T</sub> = 50%		100	150	ps	1
Jitter, Cycle to cycle	t <sub>jyc-cyc</sub>	PLL mode		40	50	ps	1,2
		Additive Jitter in Bypass Mode		25	50	ps	1,2

<sup>1</sup>Guaranteed by design and characterization, not 100% tested in production. C<sub>LOAD</sub> = 2pF

<sup>2</sup> Measured from differential cross-point to differential cross-point

<sup>3</sup> PLL mode Input-to-Output skew is measured at the first output edge following the corresponding input.

<sup>4</sup> All Bypass Mode Input-to-Output specs refer to the timing between an input edge and the specific output edge created by it.

<sup>5</sup> Duty cycle distortion is the difference in duty cycle between the output and the input clock when the device is operated in bypass mode.

<sup>6</sup> VT = 50% of Vout

<sup>7</sup> This parameter is deterministic for a given device

<sup>8</sup> Measured with scope averaging on to find mean value.

<sup>9</sup> Long-term variation from nominal of input-to-output skew over temperature and voltage for a single device.

<sup>10</sup> This parameter is measured at the outputs of two separate 9DB1904 devices driven by a single main clock. The 9DB1904's must be set to high bandwidth. Differential phase jitter is the accumulation of the phase jitter not shared by the outputs (eg. not including the affects of spread spectrum). Target ranges of consideration are agents with BW of 1-22MHz and 11-33MHz.

<sup>11</sup> t is the period of the input clock

<sup>12</sup> Differential spread spectrum tracking error is the difference in spread spectrum tracking between two 9DB1904 devices. This parameter is measured at the outputs of two separate 9DB1904 devices driven by a single main clock in Spread Spectrum mode. The 9DB1904's must be set to high bandwidth. The spread spectrum characteristics are: maximum of 0.5%, 30-33KHz modulation frequency, linear profile.

<sup>13</sup> This parameter is an absolute value. It is not a double-sided figure.



**Electrical Characteristics - Phase Jitter Parameters**

TA = T<sub>COM</sub>; Supply Voltage VDD/VDDA = 3.3 V +/-5%, See Test Loads for Loading Conditions

PARAMETER	SYMBOL	CONDITIONS	MIN	TYP	MAX	UNITS	Notes
Phase Jitter, PLL Mode	t <sub>jphPCleG1</sub>	PCIe Gen 1		35	86	ps (p-p)	1,2,3
	t <sub>jphPCleG2</sub>	PCIe Gen 2 Lo Band 10kHz < f < 1.5MHz		1.2	3	ps (rms)	1,2
		PCIe Gen 2 High Band 1.5MHz < f < Nyquist (50MHz)		2.5	3.1	ps (rms)	1,2
	t <sub>jphQPI_SMI</sub>	QPI & SMI (100MHz or 133MHz, 4.8Gb/s, 6.4Gb/s 12UI)		0.30	0.5	ps (rms)	1,5
Additive Phase Jitter, Bypass mode	t <sub>jphPCleG1</sub>	PCIe Gen 1		3	10	ps (p-p)	1,2,3
	t <sub>jphPCleG2</sub>	PCIe Gen 2 Lo Band 10kHz < f < 1.5MHz		0.01	0.3	ps (rms)	1,2,6
		PCIe Gen 2 High Band 1.5MHz < f < Nyquist (50MHz)		0.8	1.3	ps (rms)	1,2,6
	t <sub>jphQPI_SMI</sub>	QPI & SMI (100MHz or 133MHz, 4.8Gb/s, 6.4Gb/s 12UI)		0.12	0.3	ps (rms)	1,5,6

<sup>1</sup> Applies to all outputs.

<sup>2</sup> See <http://www.pcisig.com> for complete specs

<sup>3</sup> Sample size of at least 100K cycles. This figures extrapolates to 108ps pk-pk @ 1M cycles for a BER of 1-12.

<sup>4</sup> Subject to final radification by PCI SIG.

<sup>5</sup> Calculated from Intel-supplied Clock Jitter Tool v 1.6.3

<sup>6</sup> For RMS figures, additive jitter is calculated by solving the following equation: (Additive jitter)<sup>2</sup> = (total jitter)<sup>2</sup> - (input jitter)<sup>2</sup>

**Clock Periods - Differential Outputs with Spread Spectrum Disabled**

SSC OFF	Center Freq. MHz	Measurement Window							Units	Notes
		1 Clock	1us	0.1s	0.1s	0.1s	1us	1 Clock		
		-c2c jitter AbsPer Min	-SSC Short-Term Average Min	- ppm Long-Term Average Min	0 ppm Period Nominal	+ ppm Long-Term Average Max	+SSC Short-Term Average Max	+c2c jitter AbsPer Max		
DIF	100.00	9.94900		9.99900	10.00000	10.00100		10.05100	ns	1,2
	133.33	7.44925		7.49925	7.50000	7.50075		7.55075	ns	1,2

**Clock Periods - Differential Outputs with Spread Spectrum Enabled**

SSC ON	Center Freq. MHz	Measurement Window							Units	Notes
		1 Clock	1us	0.1s	0.1s	0.1s	1us	1 Clock		
		-c2c jitter AbsPer Min	-SSC Short-Term Average Min	- ppm Long-Term Average Min	0 ppm Period Nominal	+ ppm Long-Term Average Max	+SSC Short-Term Average Max	+c2c jitter AbsPer Max		
DIF	99.75	9.94906	9.99906	10.02406	10.02506	10.02607	10.05107	10.10107	ns	1,2
	133.00	7.44930	7.49930	7.51805	7.51880	7.51955	7.53830	7.58830	ns	1,2

<sup>1</sup> Guaranteed by design and characterization, not 100% tested in production.

<sup>2</sup> All Long Term Accuracy specifications are guaranteed with the assumption that the input clock complies with CK410B+/CK420BQ accuracy requirements. The 9DB1904 itself does not contribute to ppm error.

DIF Reference Clock			
Common Recommendations for Differential Routing	Dimension or Value	Unit	Figure
L1 length, route as non-coupled 50ohm trace	0.5 max	inch	1
L2 length, route as non-coupled 50ohm trace	0.2 max	inch	1
L3 length, route as non-coupled 50ohm trace	0.2 max	inch	1
$R_s$	33	ohm	1
$R_t$	49.9	ohm	1

Down Device Differential Routing			
L4 length, route as coupled microstrip 100ohm differential trace	2 min to 16 max	inch	1
L4 length, route as coupled stripline 100ohm differential trace	1.8 min to 14.4 max	inch	1

Differential Routing to PCI Express Connector			
L4 length, route as coupled microstrip 100ohm differential trace	0.25 to 14 max	inch	2
L4 length, route as coupled stripline 100ohm differential trace	0.225 min to 12.6 max	inch	2

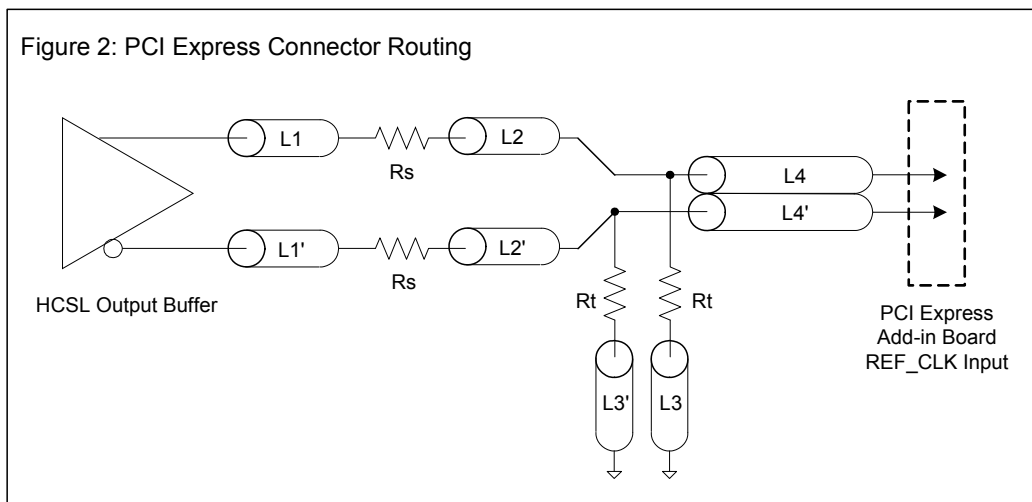
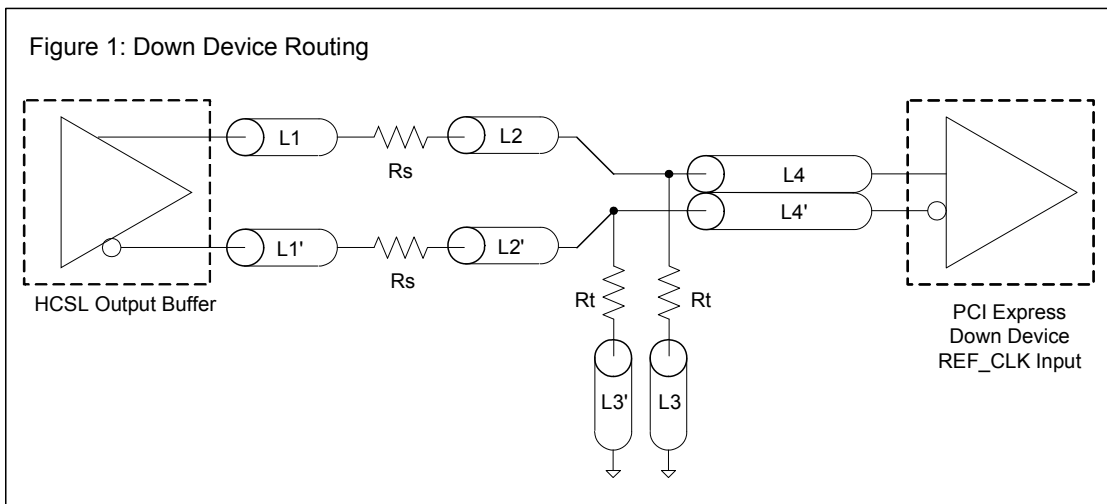

Alternative Termination for LVDS and other Common Differential Signals (figure 3)							
V <sub>diff</sub>	V <sub>p-p</sub>	V <sub>cm</sub>	R1	R2	R3	R4	Note
0.45v	0.22v	1.08	33	150	100	100	
0.58	0.28	0.6	33	78.7	137	100	
0.80	0.40	0.6	33	78.7	none	100	ICS874003i-02 input compatible
0.60	0.3	1.2	33	174	140	100	Standard LVDS

R1a = R1b = R1

R2a = R2b = R2

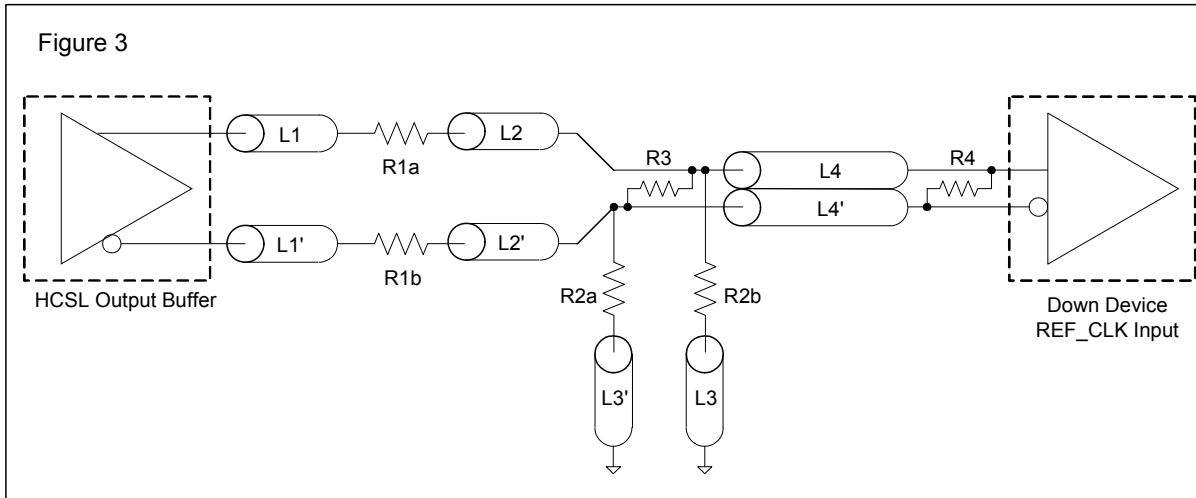

Cable Connected AC Coupled Application (figure 4)

Component	Value	Note
R5a, R5b	8.2K 5%	
R6a, R6b	1K 5%	
Cc	0.1 $\mu$ F	
V <sub>cm</sub>	0.350 volts	

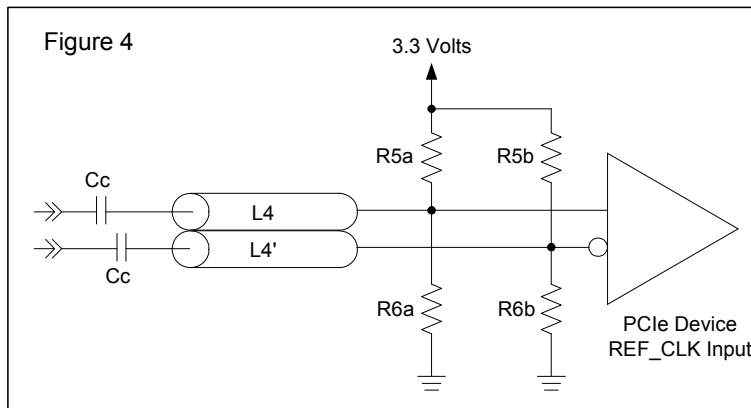

**9DB1904 SMBus Address Mapping  
when using CK410/CK410B, 9FG1200, and  
9DB403/803**

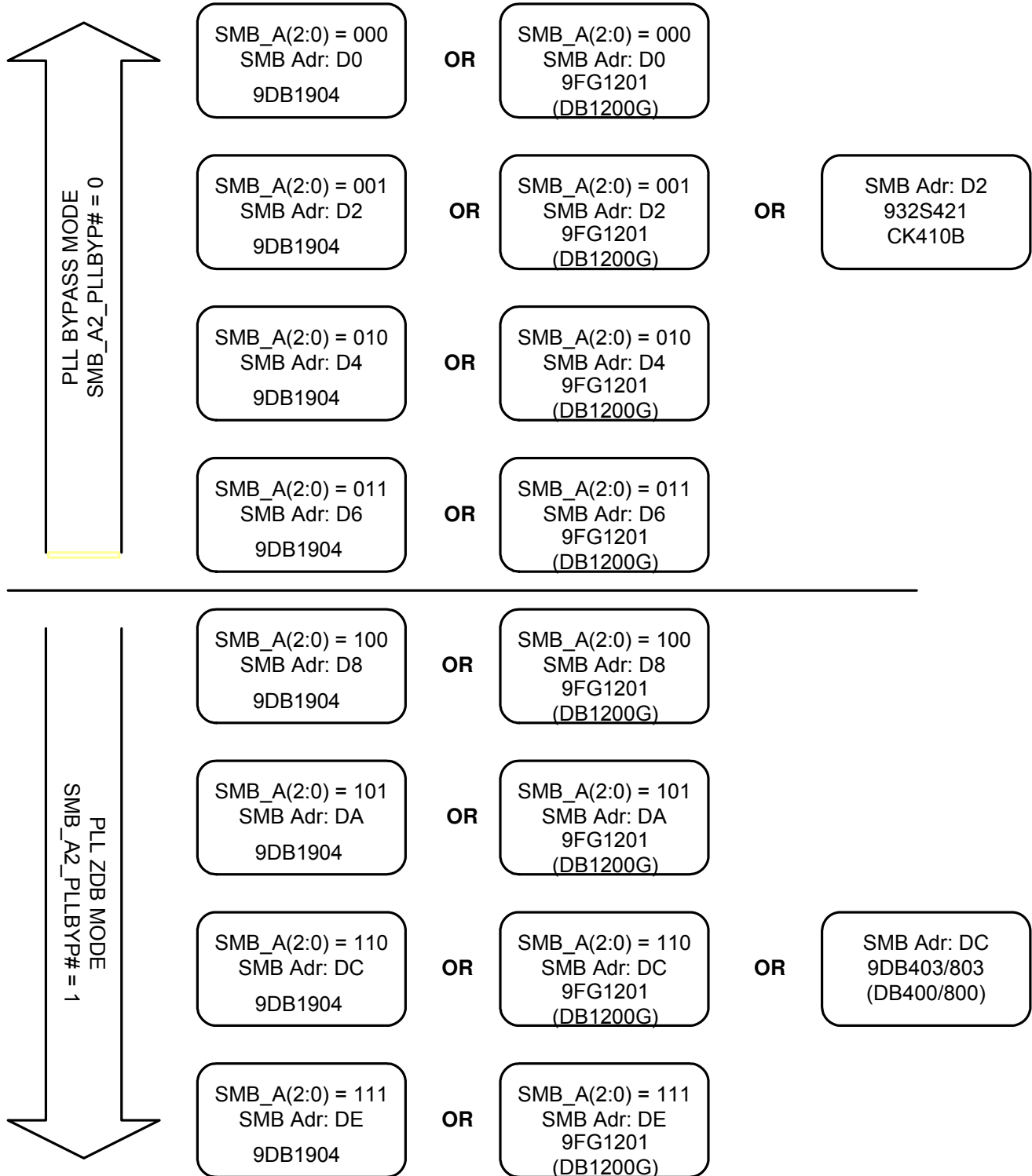

## General SMBus serial interface information for the 9DB1904B

### How to Write:

- Controller (host) sends a start bit.
- Controller (host) sends the write address  $D4_{(h)}$
- IDT clock will **acknowledge**
- Controller (host) sends the beginning byte location = N
- IDT clock will **acknowledge**
- Controller (host) sends the data byte count = X
- IDT clock will **acknowledge**
- Controller (host) starts sending **Byte N through Byte N + X - 1**
- IDT clock will **acknowledge** each byte **one at a time**
- Controller (host) sends a Stop bit

### How to Read:

- Controller (host) will send start bit.
- Controller (host) sends the write address  $D4_{(h)}$
- IDT clock will **acknowledge**
- Controller (host) sends the beginning byte location = N
- IDT clock will **acknowledge**
- Controller (host) will send a separate start bit.
- Controller (host) sends the read address  $D5_{(h)}$
- IDT clock will **acknowledge**
- IDT clock will send the data byte count = X
- IDT clock sends **Byte N + X - 1**
- IDT clock sends **Byte 0 through byte X (if  $X_{(h)}$  was written to byte 8).**
- Controller (host) will need to acknowledge each byte
- Controller (host) will send a not acknowledge bit
- Controller (host) will send a stop bit

Index Block Write Operation		
Controller (Host)		IDT (Slave/Receiver)
T	starT bit	
Slave Address $D4_{(h)}$ *		
WR	WRite	
		ACK
Beginning Byte = N		
		ACK
Data Byte Count = X		
		ACK
Beginning Byte N	X Byte	
◇		ACK
◇		◇
◇		◇
◇		◇
Byte N + X - 1		
		ACK
P	stoP bit	

Index Block Read Operation		
Controller (Host)		IDT (Slave/Receiver)
T	starT bit	
Slave Address $D4_{(h)}$ *		
WR	WRite	
		ACK
Beginning Byte = N		
		ACK
RT	Repeat starT	
Slave Address $D5_{(h)}$ *		
RD	ReaD	
		ACK
		Data Byte Count = X
ACK		
		Beginning Byte N
ACK		
◇		X Byte
◇		
◇		
◇		
		Byte N + X - 1
N	Not acknowledge	
P	stoP bit	

SMBusTable: Reserved Register

Byte 0	Pin #	Name	Control Function	Type	0	1	PWD
Bit 7	-		Reserved	R			1
Bit 6	-		Reserved	R			1
Bit 5	-		Reserved	R			1
Bit 4	-		Reserved	R			1
Bit 3	-		Reserved	R			1
Bit 2	-		Reserved	R			0
Bit 1	-		Reserved	R			1
Bit 0	-		Reserved	R			1

SMBusTable: Output Control Register

Byte 1	Pin #	Name	Control Function	Type	0	1	PWD
Bit 7		DIF_7	Output Control	RW	Hi-Z	Enable	1
Bit 6		DIF_6	Output Control	RW	Hi-Z	Enable	1
Bit 5		DIF_5	Output Control	RW	Hi-Z	Enable	1
Bit 4		DIF_4	Output Control	RW	Hi-Z	Enable	1
Bit 3		DIF_3	Output Control	RW	Hi-Z	Enable	1
Bit 2		DIF_2	Output Control	RW	Hi-Z	Enable	1
Bit 1		DIF_1	Output Control	RW	Hi-Z	Enable	1
Bit 0		DIF_0	Output Control	RW	Hi-Z	Enable	1

SMBusTable: Output and PLL BW Control Register

Byte 2	Pin #	Name	Control Function	Type	0	1	PWD
Bit 7	see note		PLL_BW# adjust	RW	High BW	Low BW	1
Bit 6	see note		BYPASS# test mode / PLL	RW	Bypass	PLL	1
Bit 5		DIF_13	Output Control	RW	Hi-Z	Enable	1
Bit 4		DIF_12	Output Control	RW	Hi-Z	Enable	1
Bit 3		DIF_11	Output Control	RW	Hi-Z	Enable	1
Bit 2		DIF_10	Output Control	RW	Hi-Z	Enable	1
Bit 1		DIF_9	Output Control	RW	Hi-Z	Enable	1
Bit 0		DIF_8	Output Control	RW	Hi-Z	Enable	1

Note: Bit 7 is wired OR to the HIGH\_BW# input, any 0 selects High BW

Note: Bit 6 is wired OR to the SMB\_A2\_PLLBYP# input, any 0 selects Fanout Bypass mode

SMBusTable: Output Enable Readback Register

Byte 3	Pin #	Name	Control Function	Type	0	1	PWD
Bit 7			Readback - OE9# Input	R	Readback		X
Bit 6			Readback - OE8# Input	R	Readback		X
Bit 5			Readback - OE7# Input	R	Readback		X
Bit 4			Readback - OE6# Input	R	Readback		X
Bit 3			Readback - OE5# Input	R	Readback		X
Bit 2			Readback - OE_01234# Input	R	Readback		X
Bit 1	8		Readback - HIGH_BW# In	R	Readback		X
Bit 0	72		Readback - SMB_A2_PLLBYP# In	R	Readback		X

**SMBusTable: Output Enable Readback Register**

Byte 4	Pin #	Name	Control Function	Type	0	1	PWD	
Bit 7	69	Readback - OE17_18#	Input	R	Readback		X	
Bit 6	60	Readback - OE15_16#	Input	R	Readback		X	
Bit 5		Reserved						0
Bit 4	54	Readback - OE14#	Input	R	Readback		X	
Bit 3	51	Readback - OE13#	Input	R	Readback		X	
Bit 2	48	Readback - OE12#	Input	R	Readback		X	
Bit 1	43	Readback - OE11#	Input	R	Readback		X	
Bit 0	40	Readback - OE10#	Input	R	Readback		X	

**SMBusTable: Vendor & Revision ID Register**

Byte 5	Pin #	Name	Control Function	Type	0	1	PWD
Bit 7	-	RID3	REVISION ID	R	-	-	0
Bit 6	-	RID2		R	-	-	0
Bit 5	-	RID1		R	-	-	0
Bit 4	-	RID0		R	-	-	1
Bit 3	-	VID3	VENDOR ID	R	-	-	0
Bit 2	-	VID2		R	-	-	0
Bit 1	-	VID1		R	-	-	0
Bit 0	-	VID0		R	-	-	1

**SMBusTable: DEVICE ID (194 Decimal or C2 Hex)**

Byte 6	Pin #	Name	Control Function	Type	0	1	PWD
Bit 7	-	Device ID 7 (MSB)		RW	Reserved		1
Bit 6	-	Device ID 6		RW	Reserved		1
Bit 5	-	Device ID 5		RW	Reserved		0
Bit 4	-	Device ID 4		RW	Reserved		0
Bit 3	-	Device ID 3		RW	Reserved		0
Bit 2	-	Device ID 2		RW	Reserved		0
Bit 1	-	Device ID 1		RW	Reserved		1
Bit 0	-	Device ID 0		RW	Reserved		0

**SMBusTable: Byte Count Register**

Byte 7	Pin #	Name	Control Function	Type	0	1	PWD
Bit 7	-	BC7	Writing to this register configures how many bytes will be read back.	RW	-	-	0
Bit 6	-	BC6		RW	-	-	0
Bit 5	-	BC5		RW	-	-	0
Bit 4	-	BC4		RW	-	-	0
Bit 3	-	BC3		RW	-	-	0
Bit 2	-	BC2		RW	-	-	1
Bit 1	-	BC1		RW	-	-	1
Bit 0	-	BC0		RW	-	-	1

**SMBusTable: Control Pin Readback Register**

Byte 8	Pin #	Name	Control Function	Type	0	1	PWD
Bit 7	5	Readback -100M_133M#_LV		R	Readback		Latch
Bit 6		RESERVED					X
Bit 5		RESERVED					X
Bit 4		DIF_18	Output Control	RW	Hi-Z	Enable	1
Bit 3		DIF_17	Output Control	RW	Hi-Z	Enable	1
Bit 2		DIF_16	Output Control	RW	Hi-Z	Enable	1
Bit 1		DIF_15	Output Control	RW	Hi-Z	Enable	1
Bit 0		DIF_14	Output Control	RW	Hi-Z	Enable	1

**SMBusTable: PLL Operating Set Point Register**

Byte 9	Pin #	Name	Control Function	Type	0	1	PWD
Bit 7		RESERVED					0
Bit 6		RESERVED					0
Bit 5		RESERVED					0
Bit 4		RESERVED					0
Bit 3		RESERVED					0
Bit 2	-	Frequency Select 100M_133M#		RW	See ICS9DB1904 1:1 PLL Programming Table		Latch
Bit 1	-	Frequency Select B		RW			0
Bit 0	-	Frequency Select A		RW			1



**9DB1904B**  
**19 Output Differential Buffer for PCIe Gen2 and QPI**

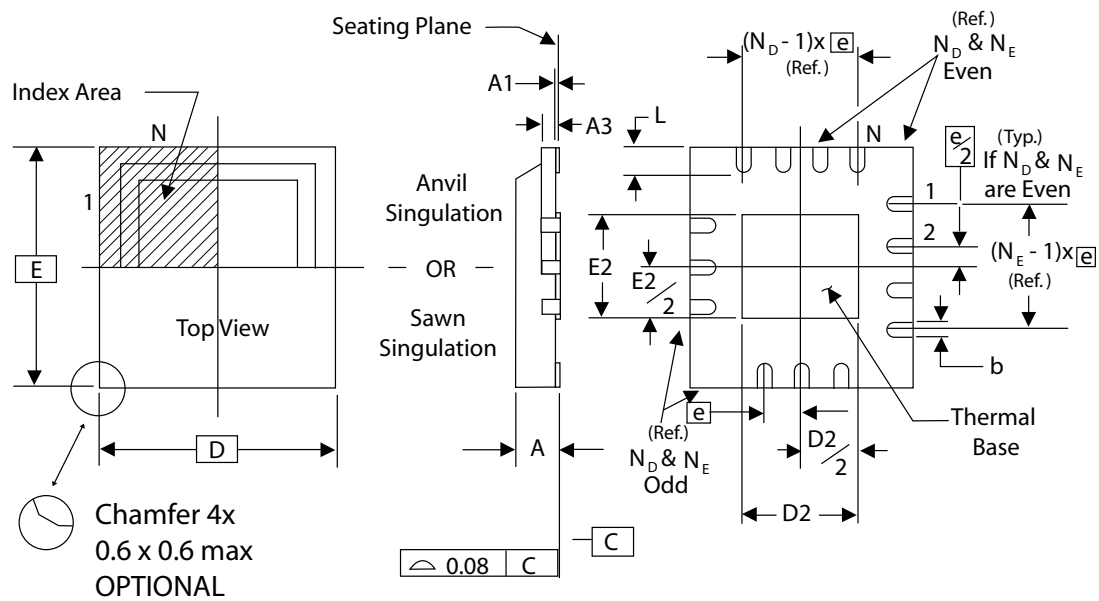

THEMALLY ENHANCED, VERY THIN, FINE PITCH  
 QUAD FLAT / NO LEAD PLASTIC PACKAGE

SYMBOL	MIN.	MAX.
A	0.8	1.0
A1	0	0.05
A3	0.25 Reference	
b	0.18	0.3
e	0.50 BASIC	

DIMENSIONS

SYMBOL	ICS 72L TOLERANCE
N	72
N <sub>D</sub>	18
N <sub>E</sub>	18
D x E BASIC	10.00 x 10.00
D2 MIN. / MAX.	5.75 / 6.15
E2 MIN. / MAX.	5.75 / 6.15
L MIN. / MAX.	0.30/ 0.50

**Ordering Information**

Part / Order Number	Shipping Packaging	Package	Temperature
9DB1904BKLF	Tubes	72-pin MLF	0 to +70° C
9DB1904BKLF	Tape and Reel	72-pin MLF	0 to +70° C

"LF" suffix to the part number are the Pb-Free configuration, RoHS compliant.  
 "B" is the device revision designator (will not correlate with the datasheet revision).

### Revision History

Rev.	Issue Date	Description	Page #
0.1	7/1/2009	Initial release	-
0.2	7/8/2009	Updated revision ID in Byte 5	13
A	9/21/2010	Updated electrical characteristics tables. Added Test loads and terminations Corrected minor typo's, move to release.	Various
B	9/23/2010	1. Updated electrical char tables 2. Updated test loads and termination figures 3. Added Period PPM tables	Various
C	4/19/2011	1. Updated electrical tabels with Typ. Values 2. Updated Differential Clock Period PPM tables	Various

## IMPORTANT NOTICE AND DISCLAIMER

RENESAS ELECTRONICS CORPORATION AND ITS SUBSIDIARIES (“RENESAS”) PROVIDES TECHNICAL SPECIFICATIONS AND RELIABILITY DATA (INCLUDING DATASHEETS), DESIGN RESOURCES (INCLUDING REFERENCE DESIGNS), APPLICATION OR OTHER DESIGN ADVICE, WEB TOOLS, SAFETY INFORMATION, AND OTHER RESOURCES “AS IS” AND WITH ALL FAULTS, AND DISCLAIMS ALL WARRANTIES, EXPRESS OR IMPLIED, INCLUDING, WITHOUT LIMITATION, ANY IMPLIED WARRANTIES OF MERCHANTABILITY, FITNESS FOR A PARTICULAR PURPOSE, OR NON-INFRINGEMENT OF THIRD PARTY INTELLECTUAL PROPERTY RIGHTS.

These resources are intended for developers skilled in the art designing with Renesas products. You are solely responsible for (1) selecting the appropriate products for your application, (2) designing, validating, and testing your application, and (3) ensuring your application meets applicable standards, and any other safety, security, or other requirements. These resources are subject to change without notice. Renesas grants you permission to use these resources only for development of an application that uses Renesas products. Other reproduction or use of these resources is strictly prohibited. No license is granted to any other Renesas intellectual property or to any third party intellectual property. Renesas disclaims responsibility for, and you will fully indemnify Renesas and its representatives against, any claims, damages, costs, losses, or liabilities arising out of your use of these resources. Renesas' products are provided only subject to Renesas' Terms and Conditions of Sale or other applicable terms agreed to in writing. No use of any Renesas resources expands or otherwise alters any applicable warranties or warranty disclaimers for these products.

(Disclaimer Rev.1.0 Mar 2020)

### Corporate Headquarters

TOYOSU FORESIA, 3-2-24 Toyosu,  
Koto-ku, Tokyo 135-0061, Japan  
[www.renesas.com](http://www.renesas.com)

### Contact Information

For further information on a product, technology, the most up-to-date version of a document, or your nearest sales office, please visit:  
[www.renesas.com/contact/](http://www.renesas.com/contact/)

### Trademarks

Renesas and the Renesas logo are trademarks of Renesas Electronics Corporation. All trademarks and registered trademarks are the property of their respective owners.