

THIS IS A CONTROLLED DOCUMENT.

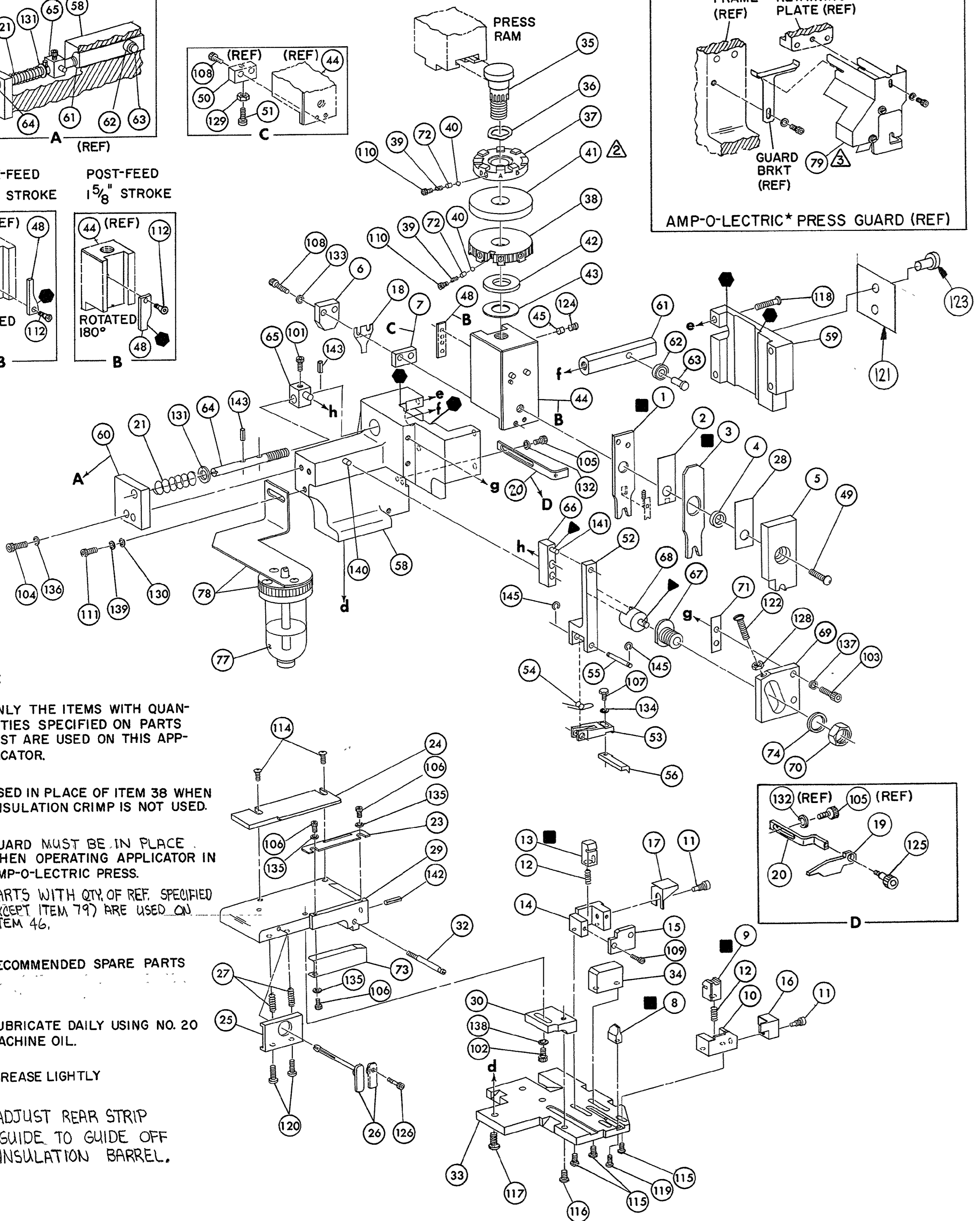
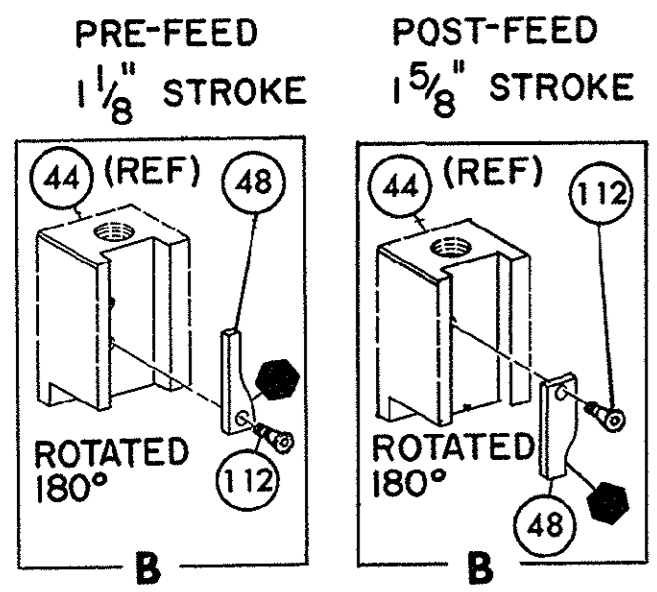
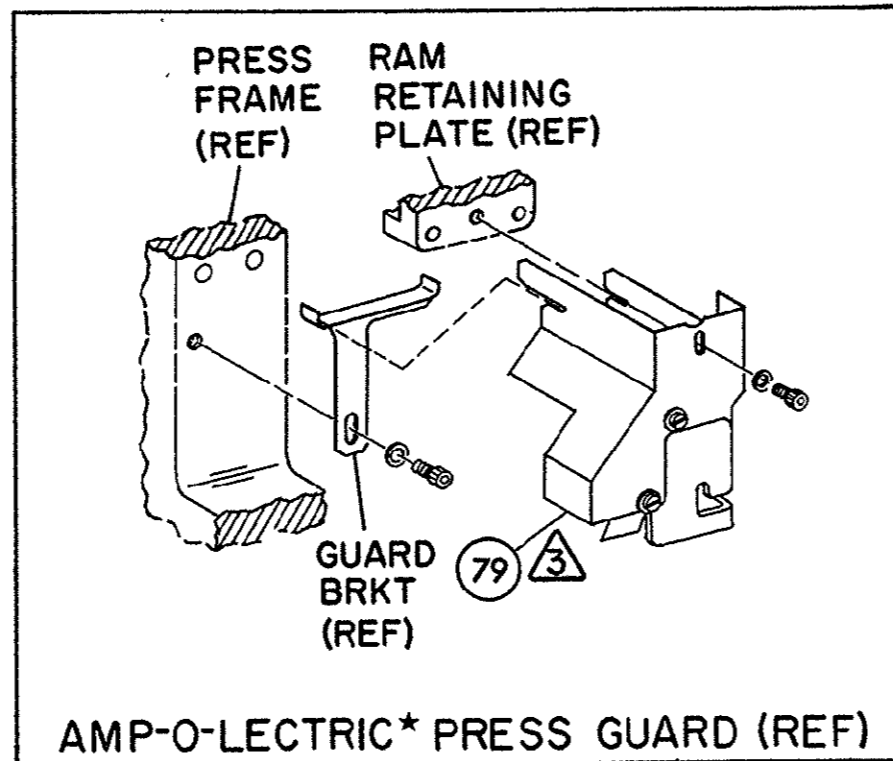
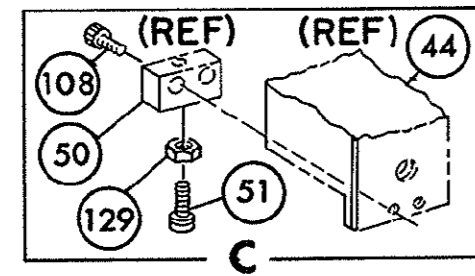
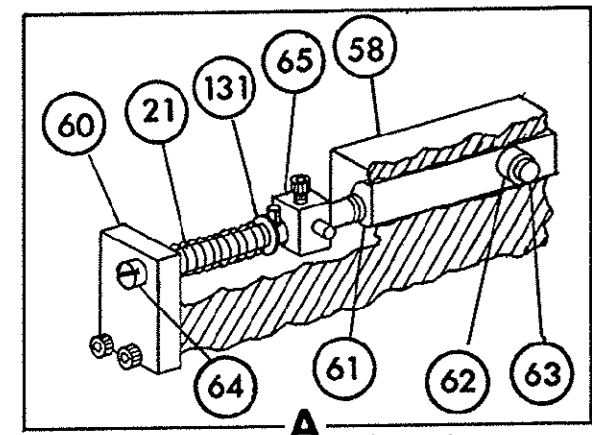

- NOTES:**
- I- ONLY THE ITEMS WITH QUANTITIES SPECIFIED ON PARTS LIST ARE USED ON THIS APPLICATOR.
  - △-USED IN PLACE OF ITEM 38 WHEN INSULATION CRIMP IS NOT USED.
  - △-GUARD MUST BE IN PLACE WHEN OPERATING APPLICATOR IN AMP-O-LECTRIC PRESS.
  - 4. PARTS WITH QTY. OF REF. SPECIFIED (EXCEPT ITEM 79) ARE USED ON ITEM 46.
- KEY:**
- RECOMMENDED SPARE PARTS
  - ▲-LUBRICATE DAILY USING NO. 20 MACHINE OIL.
  - GREASE LIGHTLY
  - △-ADJUST REAR STRIP GUIDE TO GUIDE OFF INSULATION BARREL.

REF.	QTY	PART NO	DESCRIPTION	ITEM NO
REF.		21045-3	RING, RETAINING 'C' (.187 DIA) FEED FINGER PIN	145
REF.		5-21028-1	PIN, SLOT SPR (.125 DIA X .50) ADJ ROD	143
1		4-21028-0	PIN, SLOT SPR (.093 DIA X .75) STR G PLATE	142
REF.		1-21030-1	PIN, DOWEL (.187 DIA X .50) LEVER	141
REF.		1-21030-6	PIN, DOWEL (.187 DIA X 1.25) HOUSING	140
		21024-5	WASHER, LOCK (NO 10) LUB ASSY	139
		21024-5	WASHER, LOCK (NO 10) STRIP GUIDE ADJ BLOCK	138
REF.		21024-5	WASHER, LOCK (NO 10) ADJ PLATE	137
REF.		21024-5	WASHER, LOCK (NO 10) FEED GUIDE ROD	136
2		21024-2	WASHER, LOCK (NO 4) FRONT STRIP GUIDE	135
1		21024-4	WASHER, LOCK (NO 8) FEED FINGER	134
2		21024-4	WASHER, LOCK (NO 8) DEPRESSOR	133
1		21024-4	WASHER, LOCK (NO 8) STRIPPER	132
REF.		21899-4	WASHER, FLAT (5/16 DIA) SCREW ADJ	131
		21899-2	WASHER, FLAT (NO 10) LUB ASSY	130
1		21018-5	NUT, HEX MACH (6-32) HOLDDOWN	129
REF.		21018-5	NUT, HEX MACH (6-32) FEED ADJ	128
				127
		22353-8	SCR, SHLD. (.187 DIA X .250 LG) DRAG LEVER	126
1		456567-1	SCR, SHLD. (188 DIA X .125 LG) STRIPPER	125
1		21009-2	SCR, SKT SET (1/4-20 X .25) (LOC-WEL) RAM	124
2		21017-2	SCREW, DRIVE #2 X .19	123
REF.		6-23715-5	SCR, RD HD MACH (6-32 X 1.50) FEED ADJ	122
1		461264-1	PLATE, IDENTIFICATION	121
2		2-21002-9	SCR, BUT HD SKT CAP (10-32 X .75) DRAG	120
1		22739-3	SCR, BUT HD SKT CAP (8-32 X .38) (LOC-WEL) ANVIL	119
REF.		2-21002-9	SCR, BUT HD SKT CAP (10-32 X .75) CAP	118
REF.		17177-1	SCR, BUT HD SKT CAP (1/4-20 X .75) HOUSING	117
REF.		2-21002-7	SCR, BUT HD SKT CAP (10-32 X .50) SG ADJ BLOCK	116
4		2-21002-2	SCR, BUT HD SKT CAP (8-32 X .50) SHEAR	115
2			SCR, BUT HD SKT CAP (8-32 X .50) R STRIP GUIDE	114
				113
1		1-21002-7	SCR, BUT HD SKT CAP (6-32 X .38) CAM	112
1		3-21000-4	SCR, SKT HD CAP (10-32 X .38) LUBRICATOR ASSY	111
2		23030-1	SCR, SKT HD CAP (6-32 X .25) (LOC-WEL) CP DISC	110
			SCR, SKT HD CAP (6-32 X ) REAR SHEAR PLATE	109
2		2-21000-8	SCR, SKT HD CAP (8-32 X .62) DEPRESSOR	108
1		2-22603-0	SCR, HEX HD MACH (8-32 X .31) FEED FINGER	107
2		1-21000-3	SCR, SKT HD CAP (4-40 X .25) F STRIP GUIDE	106
1		2-21000-7	SCR, SKT HD CAP (8-32 X .50) STRIPPER	105
REF.		3-21000-7	SCR, SKT HD CAP (10-32 X .75) FEED ROD GUIDE	104
REF.		3-21000-6	SCR, SKT HD CAP (10-32 X .62) FEED ADJ BLOCK	103
1		3-21000-4	SCR, SKT HD CAP (10-32 X .38) SG ADJ BLOCK	102
REF.		3-21000-4	SCR, SKT HD CAP (10-32 X .38) PIVOT BLOCK	101
REF.		455749-1	GUARD (WINDOW)	79
1		1-465184-0	LUBRICATOR ASSY	78
REF.		852931-2	OIL, LUBRICATING	77
				76
				75
REF.		458109-1	WASHER, SPECIAL	74
		454877-3	PLATE, STRIP GUIDE COVER	73
2		690603-1	SPRING, ASSIST	72
REF.		690517-1	SPACER	71
		22594-8	NUT, HEX	70
		240628-1	PLATE, ADJUSTMENT	69
		240626-1	SHAFT, PIVOT	68
		240633-1	BUSHING	67
		455680-1	LEVER, INTERMEDIATE	66
		240629-1	BLOCK, PIVOT	65
		240632-2	SCREW, ADJUSTMENT FEED ROD	64
		240659-3	PIN, CAM ROLLER	63
		240658-1	ROLLER, CAM	62
		454398-2	ROD, FEED	61
REF.		454178-1	GUIDE, FEED ROD	60
QTY		PART NO	DESCRIPTION	ITEM NO

REMARKS	NO	REV
TO APPLY TERMINAL SPEC 114-4003		
APPL USED ON MACHINE PART NO	MACH SERIAL NO	DISTRIBUTION
CUSTOMER NAME	APPL SERIAL NO	ORIGINAL
ADDRESS	PURCHASE ORDER	CUSTOMER COPY
CITY	ENG APP	FIELD ENG COPY

CRIMPING DATA				APPLICATOR WILL APPLY	
PAD LTR	CRIMP HEIGHT	WIRE SIZE	STRIP LENGTH	PIN	SOCKET
A	.042	18		745267	745270
B	NOT USED				
C	.034	20 OR 22			
D	NOT USED				
CRIMP	SIZE	TYPE	FEED	APPL INST	
WIRE	.062	F	.300	A1 8040	
INSUL	.076	F			
WIRE RANGE	22-18	INSULATION RANGE	.070 MAX	PRESS NO	565435-5
REMARKS					
PRE-FEED AMP-O-LECTRIC					

SET UP GAGE	10-1	458637-1	11260	APP NO	1194	REV	
OR				NUMBER			
CHK UNIT	REL	LOC	A	D	NO	56180-2	REV
NAME	MINIATURE QUICK CHANGE APPLICATOR						
NAME	SIDE FEED (HDE-20 PIN & SOC)						

