

VICOR CONFIDENTIAL
 THIS DOCUMENT AND THE DATA DISCLOSED HEREIN OR
 HEREWITH IS NOT TO BE REPRODUCED, USED OR
 DISCLOSED IN WHOLE OR IN PART TO ANYONE WITHOUT
 THE PERMISSION OF VICOR CORP.

REV.	DESCRIPTION	DATE	APPROVED
1	RELEASED PER E090355 AR	02/20/09	REJH
2	REVISED PER E111016 KUK	10/13/11	GCK

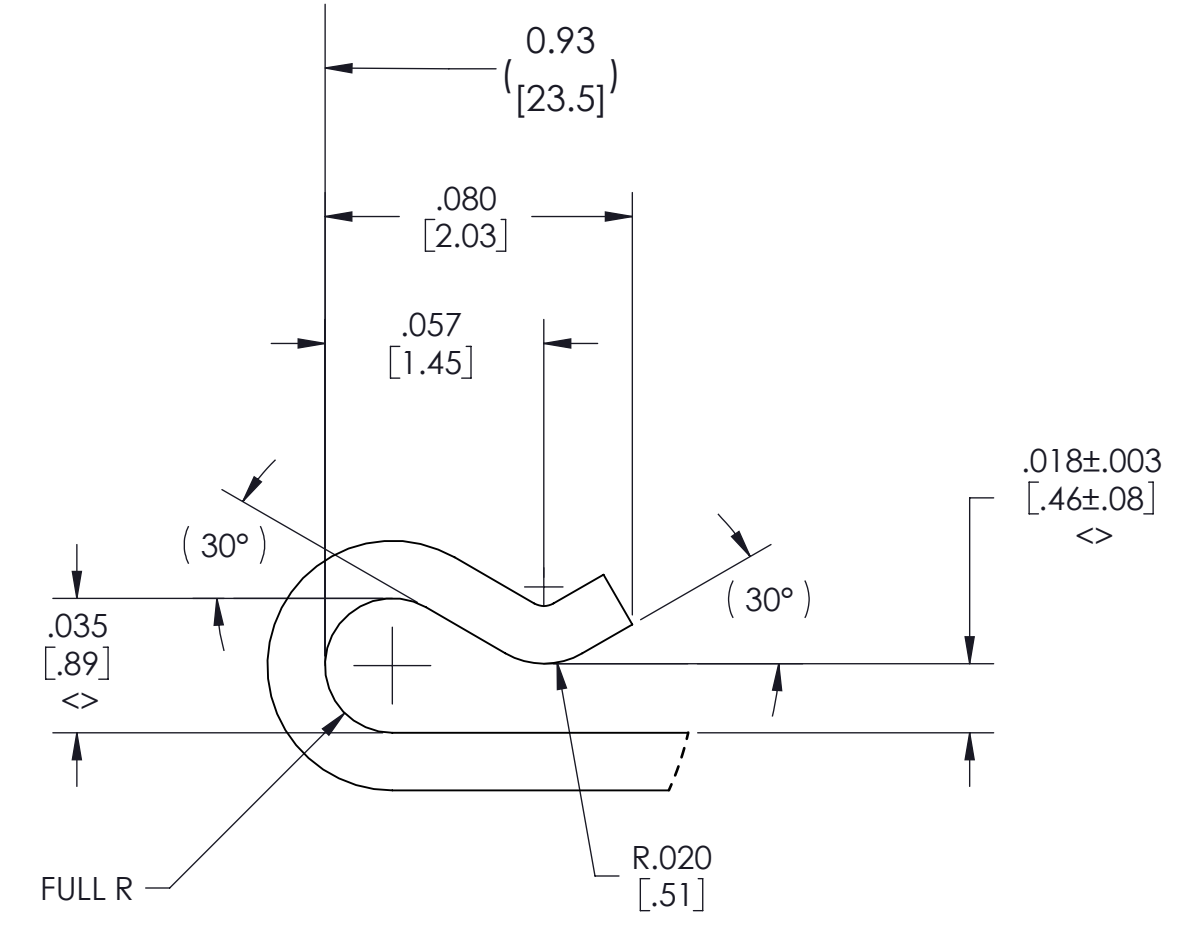
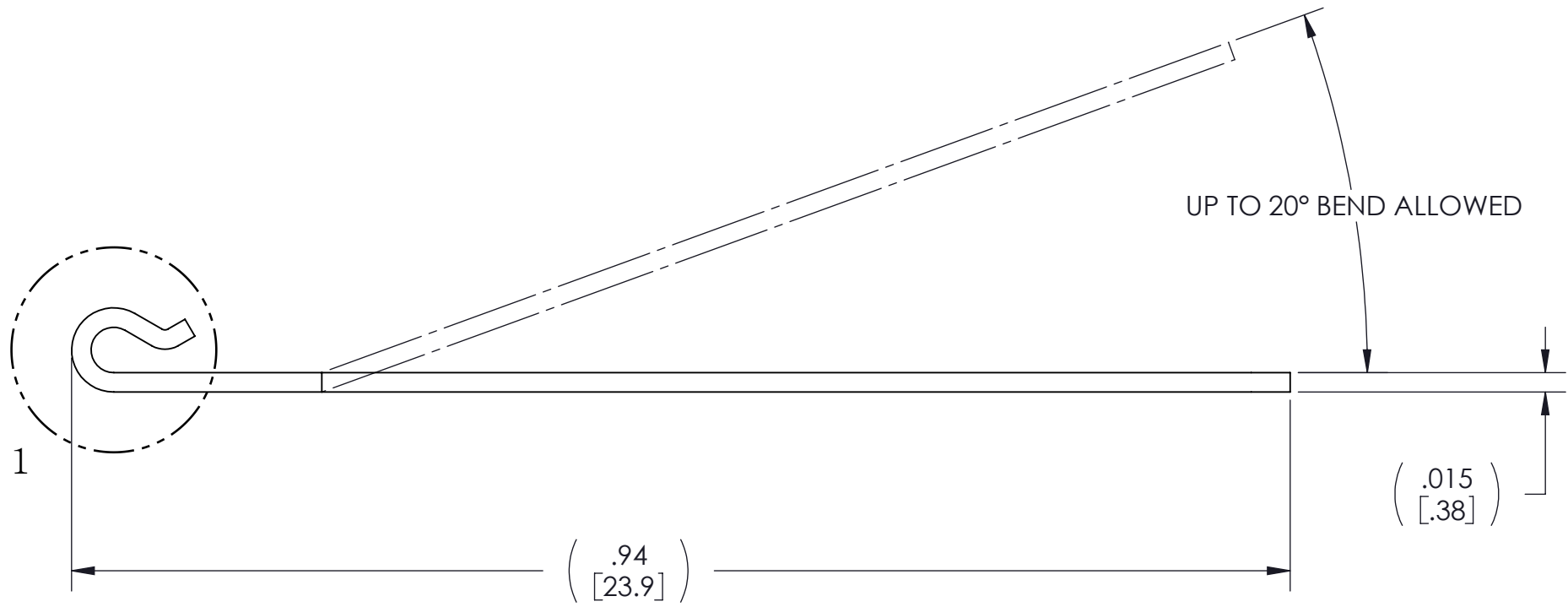
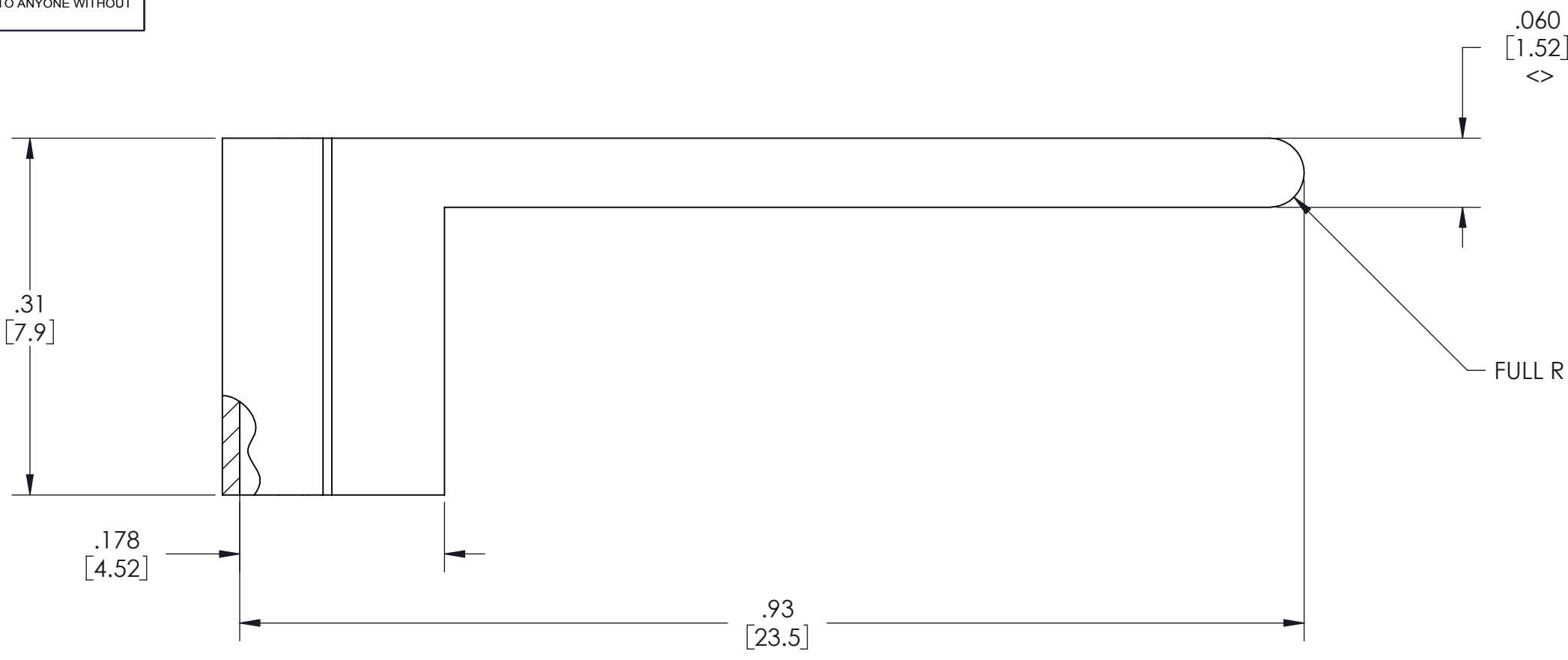

DETAIL 1
 SCALE 20 : 1

SEE DETAIL 1

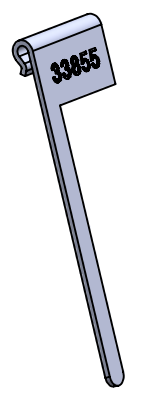
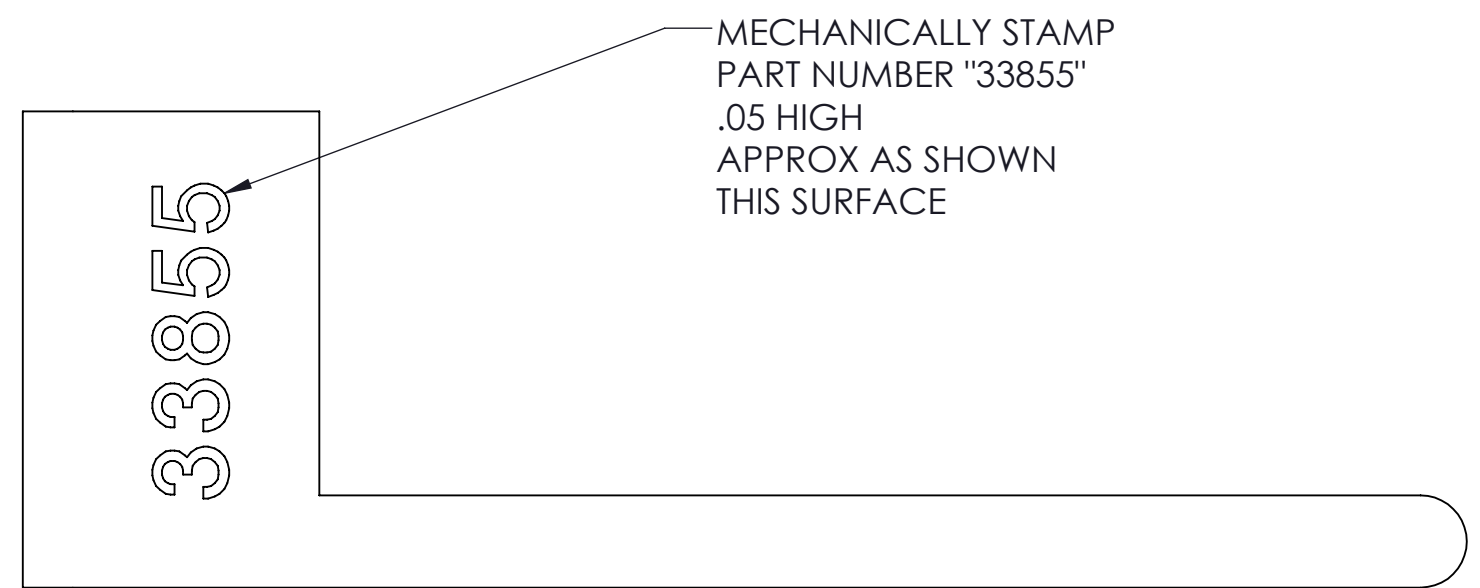

- NOTES:
1. MATERIAL: 260 BRASS, .015 THK, HALF HARD.
 2. FINISH: MATTE TIN OR FUSED MATTE TIN, 300-500 MICRO INCHES OVER 100-200 MICRO INCHES NICKEL.
 3. RoHS COMPLIANT, LEAD FREE PER CST-0001 LATEST REVISION.
 4. <> DENOTES CRITICAL CHARACTERISTIC FOR LOT INSPECTION.

DRAWN BY R.E.J.Hickey	DATE 05/16/07	VICOR		SWD	
UNLESS OTHERWISE SPECIFIED DIMENSIONS ARE : INCH / (MM)		CLIP HEATSINK GROUNDING			
TOLERANCES ARE: DECIMALS ANGLES X.XX [X.X] = ±0.01 [0.25] ±1° X.XXX [X.XX] = ±0.005 [0.127]		SIZE C	CAGE CODE 67131	DWG NO 33855	REV 2
THIRD ANGLE PROJECTION DO NOT SCALE DRAWING		SCALE 8:1	SHEET 1 OF 1		