

THIS DRAWING IS UNPUBLISHED. RELEASED FOR PUBLICATION. COPYRIGHT BY TYCO ELECTRONICS CORPORATION. ALL INTERNATIONAL RIGHTS RESERVED.

PART NUMBER	REV	FIRST USED
680646-1	B	122500-1
680646-2	B	565435-5

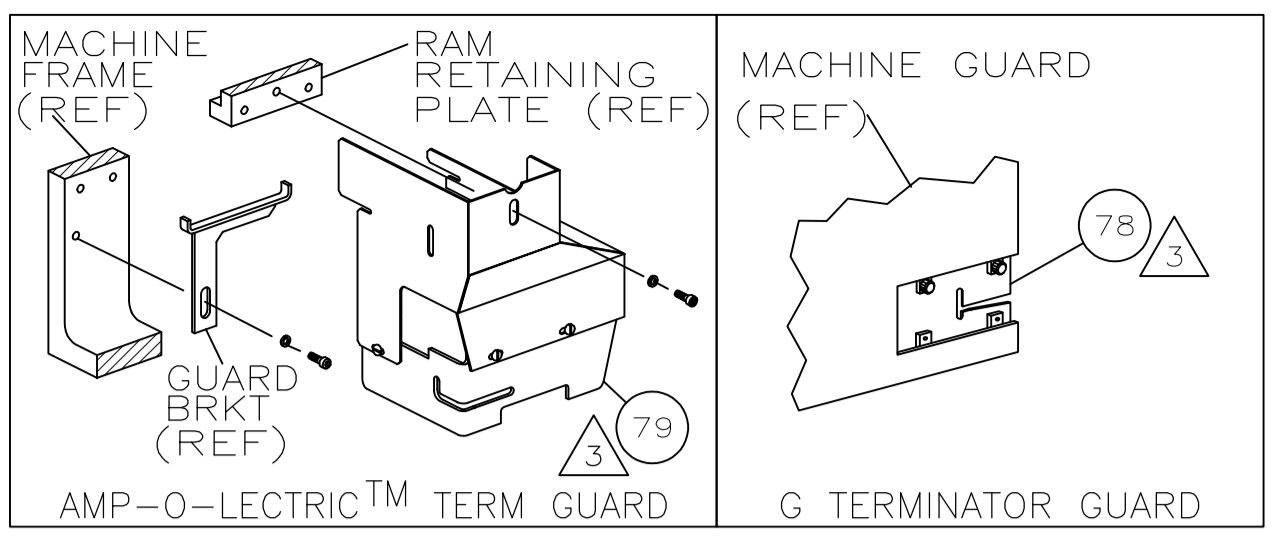

TERMINAL NAME: TERMINAL, RECEPTAL

1217092	CRIMP DATA (AMP TERMINAL)
	PAD LTR CRIMP HEIGHT WIRE SIZE
A	.070 ±.002 [1.78 ±0.05mm] (2) 16
B	.067 ±.002 [1.70 ±0.05mm] (1)16 & (1)18
C	.063 ±.002 [1.60 ±0.05mm] (2) 18
D	.059 ±.002 [1.50 ±0.05mm] (1)16 OR (1)18 + (2)20
	CRIMP SIZE TYPE RANGE
	WIRE .140 [3.56mm] F 16,(2)18 OR (2)16
	INSUL .240 [6.10mm] F .120-.170 OR (2).120MAX
WIRE STRIP LENGTH	TERM APPL SPEC FEED APPL INSTRUCTION SET UP GAGE LAYOUT
.215-.245	114-2074 .845 408-8039 458638-1 L2082

LOC	DIST	REVISIONS			
F	LTR	DESCRIPTION	DATE	BY	APVD
B1	ECR-09-014363		6-2009	MY	GB

-1	LEADMAKER & BENCH MODEL G	MECH POST FEED
-2	BENCH MODEL K	MECH POST FEED

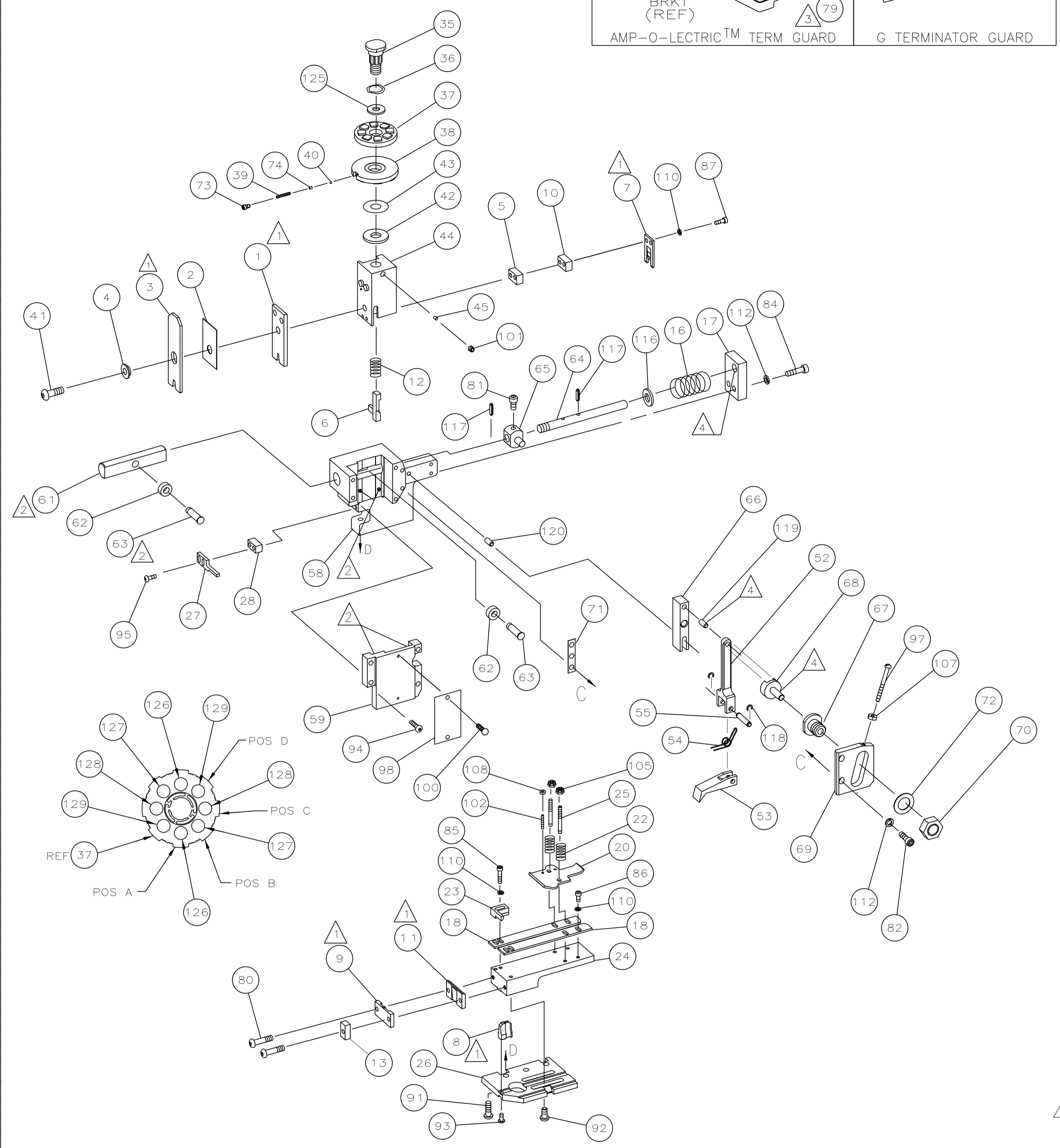

2	2	-	2-354779-4	PIN, WIRE DISC (.3110)D	129
2	2	-	1-354779-5	PIN, WIRE DISC (.3065)C	128
2	2	-	354779-7	PIN, WIRE DISC (.3025)B	127
2	2	-	9-354778-9	PIN, WIRE DISC (.2990)A	126
1	1	-	986950-1	WASHER, FLAT PRECISION	125
1	1	-	217238-1	GENERAL INSTRUCTION PACKAGE	124
1	1	-	4088039	EF APPL INST 408-8039	123
					122
					121
REF	REF	-	1-21030-7	PIN,DOWEL(Ø.187x1.50)HSG	120
REF	REF	-	1-21030-1	PIN,DOWEL(Ø.187x.50)LEVER	119
REF	REF	-	21045-3	RING,RET"C"(Ø.187)FD PIN	118
REF	REF	-	5-21028-1	PIN,STD SPRING(Ø.12)FD ADJ ROD	117
REF	REF	-	21899-4	WASHER,FLAT(Ø5/16)SCR ADJ	116
					115
					114
					113
REF	REF	-	21024-5	WASHER,LOCK(NO.10)FD ROD GDE	112
					111
7	7	-	21024-4	WASHER,LOCK(NO.8)SHEAR BL	110
					109
2	2	-	21018-4	NUT,HEX(4-40)DRAG	108
REF	REF	-	21018-5	NUT,HEX(6-32)FD ADJ PL	107
					106
2	2	-	21022-2	NUT,HEX SL(8-32)DRAG STUD	105
					104
					103
2	2	-	2-21006-6	SCR,SKT SET(4-40x.62)DRAG	102
1	1	-	21009-2	SCR,SKT SET(1/4-20x.25)RAM	101
2	2	-	21017-2	SCR,DRIVE(#2x.19)ID PLATE	100
1	1	-	1-21002-7	SCR,BHC(6-32x.38)CAM	99
1	1	-	461264-1	PLATE, IDENTIFICATION	98
REF	REF	-	6-23715-5	SCR,PAN HD(6-32x1.50)FEED ADJ	97
					96
2	2	-	2-21002-2	SCR,BHC(8-32x.50)STRIPPER	95
REF	REF	-	2-21002-9	SCR,BHC(10-32x.75)HSG CAP	94
1	1	-	22733-8	SCR,BHC(8-32x.38 LW)ANVIL	93
4	4	-	3-21002-3	SCR,BHC(1/4-20x.50)ST GD PL	92
REF	REF	-	2-22733-8	SCR,BHC(1/4-20x.62)BASE PL	91
					90
					89
					88
2	2	-	2-21000-7	SCR,SHC(8-32x.50)SLUG BLADE	87
3	3	-	2-21000-6	SCR,SHC(8-32x.38)STRIP GUIDE	86
2	2	-	2-21000-9	SCR,SHC(8-32x.75)R STRIP GUIDE	85
REF	REF	-	3-21000-7	SCR,SHC(10-32x.75)FEED ROD GDE	84
					83
REF	REF	-	3-21000-6	SCR,SHC(10-32x.62)FEED ADJ PL	82
REF	REF	-	3-21000-4	SCR,SHC(10-32x.38)PIVOT BLOCK	81
2	2	-	3-21002-0	SCR,BHC(10-32x.88)SHEAR PL	80
REF	-	-	455745-1	GUARD, WINDOW	79
REF	-	-	679532-1	INSERT, GUARD	78
					77
					76
					75
1	1	-	690603-1	SPRING, ASSIST	74
1	1	-	23030-1	SCR,SKT CAP(6-32x.25)CP DSC	73
REF	REF	-	458109-1	WASHER, FLAT (SPECIAL)	72
REF	REF	-	690517-1	SPACER	71
					70
					69
					68
					67
					66
					65
					64
					63
					62
					61
					60
					59
					58
					57
					56
					55
REF	REF	-	240624-1	PIN, FEED FINGER	54
REF	REF	-	691499-1	SPRING, FEED FINGER	53
REF	REF	-	240635-1	FINGER, FEED	52
REF	REF	-	240634-1	LEVER, TERMINAL	51
					50
					49
1	-	-	690501-3	CAM, POST FEED 1 1/8 ST	48
-	1	-	690501-4	CAM, POST-FEED 1 5/8 ST	47
					46
1	1	-	690191-1	PLUG, NYLON	45
1	1	-	455674-1	RAM	44
1	1	-	690125-1	WASHER, LAMINATED	43
1	1	-	690124-1	WASHER, RAM	42
1	1	-	7-21002-9	BOLT, CRIMPER(5/16-24x1.00)	41
1	1	-	23241-6	BALL, STEEL	40
1	1	-	690170-1	SPRING, COMPRESSION	39
1	1	-	1-690142-1	DISC, INSULATION	38
1	1	-	354777-1	WIRE DISC, PLASTIC	37
1	1	-	22480-5	WASHER, SPRING	36
1	1	-	690212-1	POST, RAM	35
					34
					33
1	1	-	458980-1	APPLICATOR, BASIC (SUB ASSY)	32
					31
					30
					29
1	1	-	3-690451-2	SPACER, STRIPPER	28
1	1	-	240639-1	STRIPPER	27
REF	REF	-	455676-1	PLATE, BASE	26
2	2	-	22354-8	DRAG, STUD	25
1	1	-	455678-1	PLATE, STRIP GUIDE	24
1	1	-	240825-2	PLATE, STRIP HOLD DOWN	23
2	2	-	4-22281-1	SPRING, DRAG	22
					21
1	1	-	454177-1	DRAG, STOCK	20
					19
2	2	-	454204-4	GUIDE, STRIP (FRONT)	18
REF	REF	-	454178-1	GUIDE, FEED ROD	17
REF	REF	-	4-22284-9	SPRING, FEED RETURN	16
					15
					14
1	1	-	1-690481-3	SPACER, HOLD DOWN	13
1	1	-	23846-1	SPRING, HOLD DOWN	12
1	1	-	240644-1	PLATE, REAR SHEAR	11
1	1	-	1-240641-2	SPACER, SLUG BLADE	10
1	1	-	690482-5	PLATE, FRONT SHEAR	9
1	1	-	1213559-1	ANVIL	8
1	1	-	1-690474-6	BLADE, SLUG	7
1	1	-	1-455892-0	HOLD DOWN, TERMINAL	6
1	1	-	4-240641-3	SPACER, SLUG BLADE	5
1	1	-	238009-3	SPACER, BLOCK CRIMPER	4
1	1	-	3-456134-5	CRIMPER, INSULATION	3
1	1	-	455888-4	SPACER, CRIMPER	2
1	1	-	1-456411-8	CRIMPER, WIRE	1

REF	REF	QTY	PART NO	DESCRIPTION	ITEM NO
REF	REF	-	22594-8	NUT, HEX	70
REF	REF	-	240628-1	PLATE, ADJ	69
REF	REF	-	240626-1	SHAFT, PIVOT	68
REF	REF	-	240633-1	BUSHING	67
REF	REF	-	455680-1	LEVER, INTERMEDIATE	66
REF	REF	-	240629-1	BLOCK, PIVOT	65
REF	REF	-	240632-2	SCR, ADJ	64
REF	REF	-	240659-3	PIN, CAM ROLLER	63
REF	REF	-	240658-1	CAM, ROLLER	62
REF	REF	-	454398-1	ROD, FEED	61
					60
REF	REF	-	454220-1	CAP, RAM	59
REF	REF	-	453736-1	HOUSING	58
					57
					56
REF	REF	-	240624-1	PIN, FEED FINGER	55
REF	REF	-	691499-1	SPRING, FEED FINGER	54
REF	REF	-	240635-1	FINGER, FEED	53
REF	REF	-	240634-1	LEVER, TERMINAL	52
					51
					50
					49
1	-	-	690501-3	CAM, POST FEED 1 1/8 ST	48
-	1	-	690501-4	CAM, POST-FEED 1 5/8 ST	47
					46
1	1	-	690191-1	PLUG, NYLON	45
1	1	-	455674-1	RAM	44
1	1	-	690125-1	WASHER, LAMINATED	43
1	1	-	690124-1	WASHER, RAM	42
1	1	-	7-21002-9	BOLT, CRIMPER(5/16-24x1.00)	41
1	1	-	23241-6	BALL, STEEL	40
1	1	-	690170-1	SPRING, COMPRESSION	39
1	1	-	1-690142-1	DISC, INSULATION	38
1	1	-	354777-1	WIRE DISC, PLASTIC	37
1	1	-	22480-5	WASHER, SPRING	36
1	1	-	690212-1	POST, RAM	35
					34
					33
1	1	-	458980-1	APPLICATOR, BASIC (SUB ASSY)	32
					31
					30
					29
1	1	-	3-690451-2	SPACER, STRIPPER	28
1	1	-	240639-1	STRIPPER	27
REF	REF	-	455676-1	PLATE, BASE	26
2	2	-	22354-8	DRAG, STUD	25
1	1	-	455678-1	PLATE, STRIP GUIDE	24
1	1	-	240825-2	PLATE, STRIP HOLD DOWN	23
2	2	-	4-22281-1	SPRING, DRAG	22
					21
1	1	-	454177-1	DRAG, STOCK	20
					19
2	2	-	454204-4	GUIDE, STRIP (FRONT)	18
REF	REF	-	454178-1	GUIDE, FEED ROD	17
REF	REF	-	4-22284-9	SPRING, FEED RETURN	16
					15
					14
1	1	-	1-690481-3	SPACER, HOLD DOWN	13
1	1	-	23846-1	SPRING, HOLD DOWN	12
1	1	-	240644-1	PLATE, REAR SHEAR	11
1	1	-	1-240641-2	SPACER, SLUG BLADE	10
1	1	-	690482-5	PLATE, FRONT SHEAR	9
1	1	-	1213559-1	ANVIL	8
1	1	-	1-690474-6	BLADE, SLUG	7
1	1	-	1-455892-0	HOLD DOWN, TERMINAL	6
1	1	-	4-240641-3	SPACER, SLUG BLADE	5
1	1	-	238009-3	SPACER, BLOCK CRIMPER	4
1	1	-	3-456134-5	CRIMPER, INSULATION	3
1	1	-	455888-4	SPACER, CRIMPER	2
1	1	-	1-456411-8	CRIMPER, WIRE	1

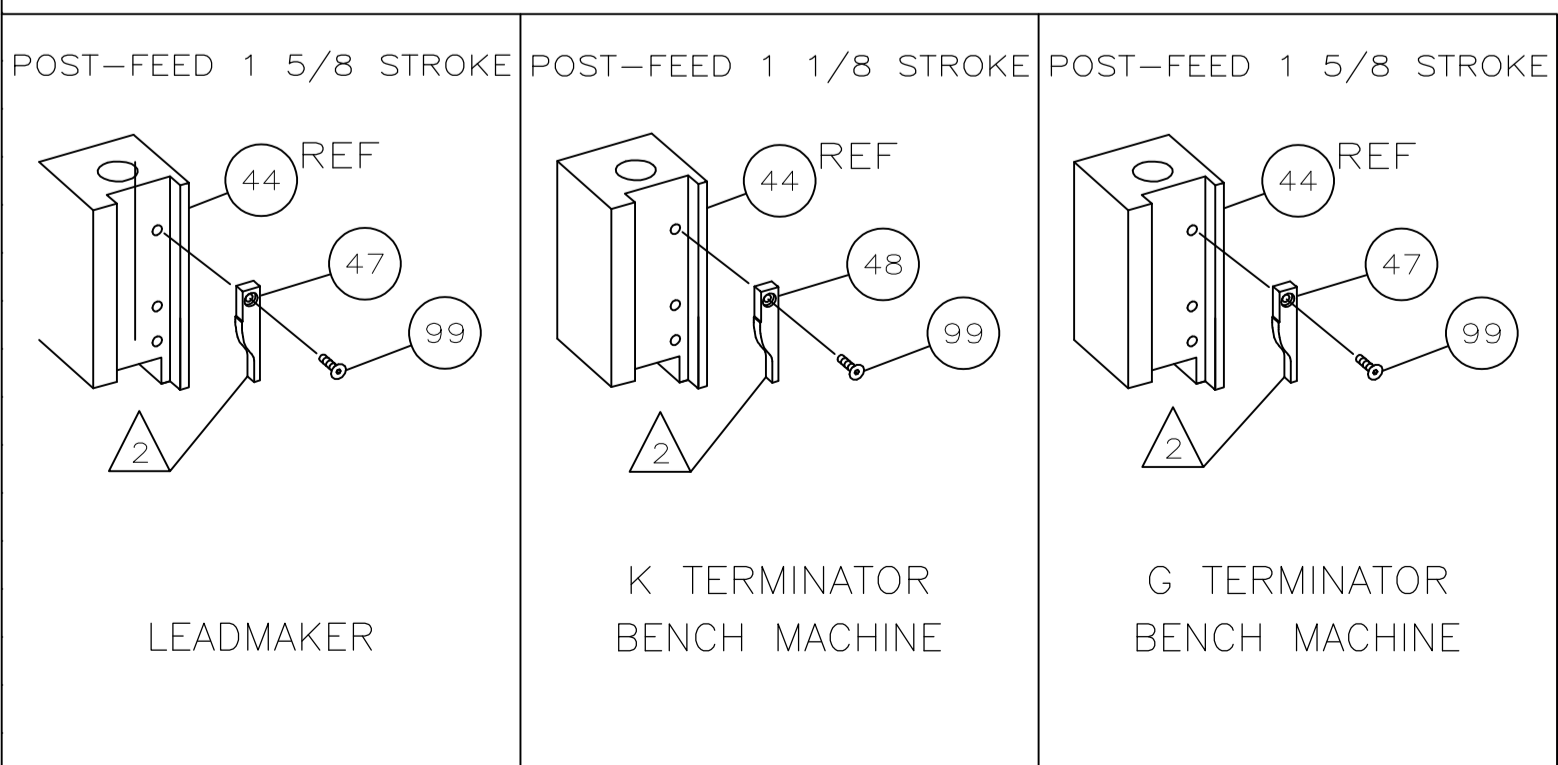

- 1 RECOMMENDED SPARE PARTS.
- 2 GREASE LIGHTLY.
- 3 GUARD MUST BE IN PLACE WHEN OPERATING APPLICATOR IN A BENCH MACHINE.
- 4 LUBRICATE DAILY USING NO. 20 MACHINE OIL.
- 5. ITEMS WITH QTY OF REF SPECIFIED (EXCEPT ITEMS 78 AND 79) ARE USED ON ITEM 32.
- 6 ITEM 78 USED WITH G TERMINATOR ONLY.

QTY REQD PER ASSY	PART NO	DESCRIPTION	ITEM NO
-2	-1	U/M	

QTY REQD PER ASSY	PART NO	DESCRIPTION	ITEM NO
-2	-1	U/M	

THIS DRAWING IS A CONTROLLED DOCUMENT.

DIMENSIONS: INCHES	TOLERANCES UNLESS OTHERWISE SPECIFIED:	APPROVED: J. ELBIN	DATE: 22JUN98	NAME: J. ELBIN
0 PLC ± .005	1 PLC ± .002	Tyco Electronics Corporation Harrisburg, PA 17105-3608		
2 PLC ± .001	3 PLC ± .0005	END FEED HDM APPLICATOR		
4 PLC ± .0002	ANGLES ± .001	SIZE: A1	CAGE CODE: 00779	DRAWING NO: 680646
MATERIAL: -	FINISH: -	WEIGHT: -	SCALE: -	SHEET 1 OF 1 REV B1