

PRODUCT NO
SEE TABLE

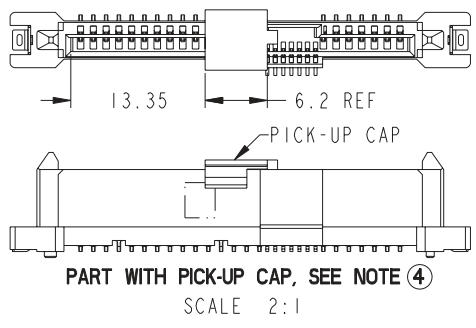
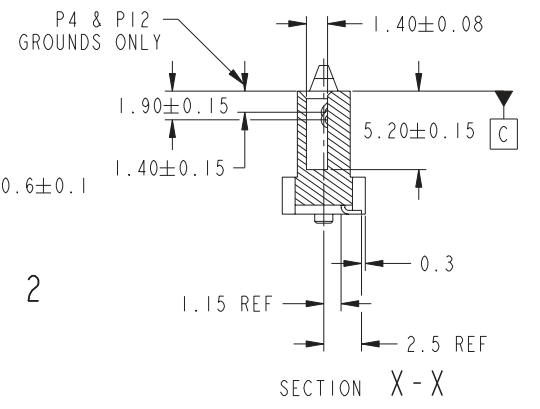
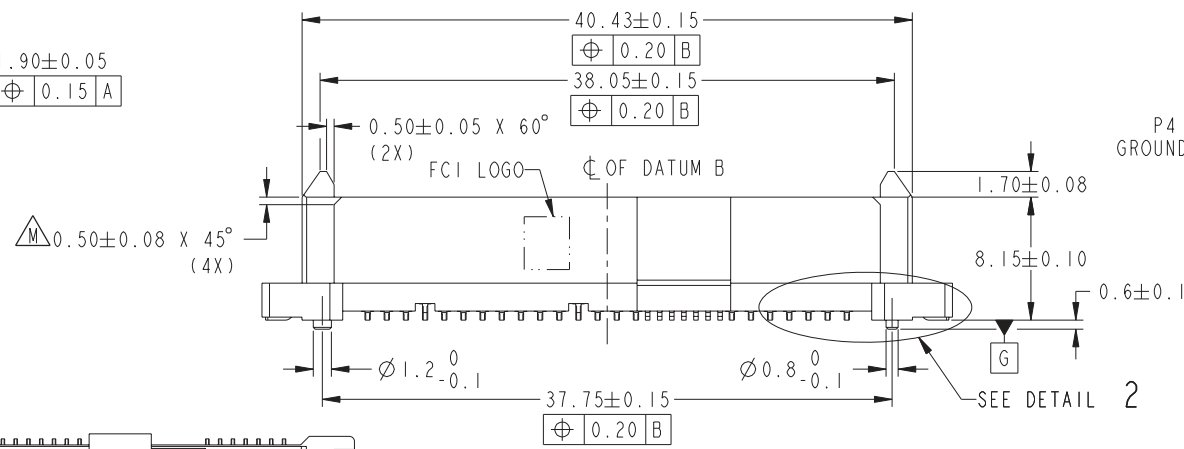
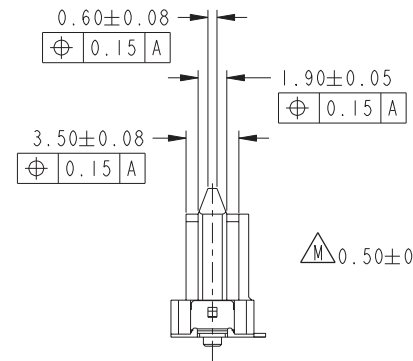
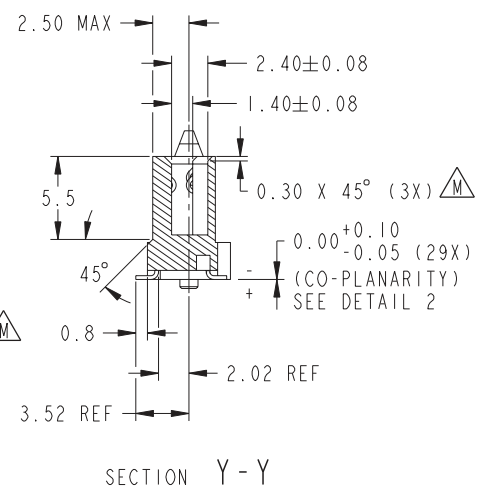
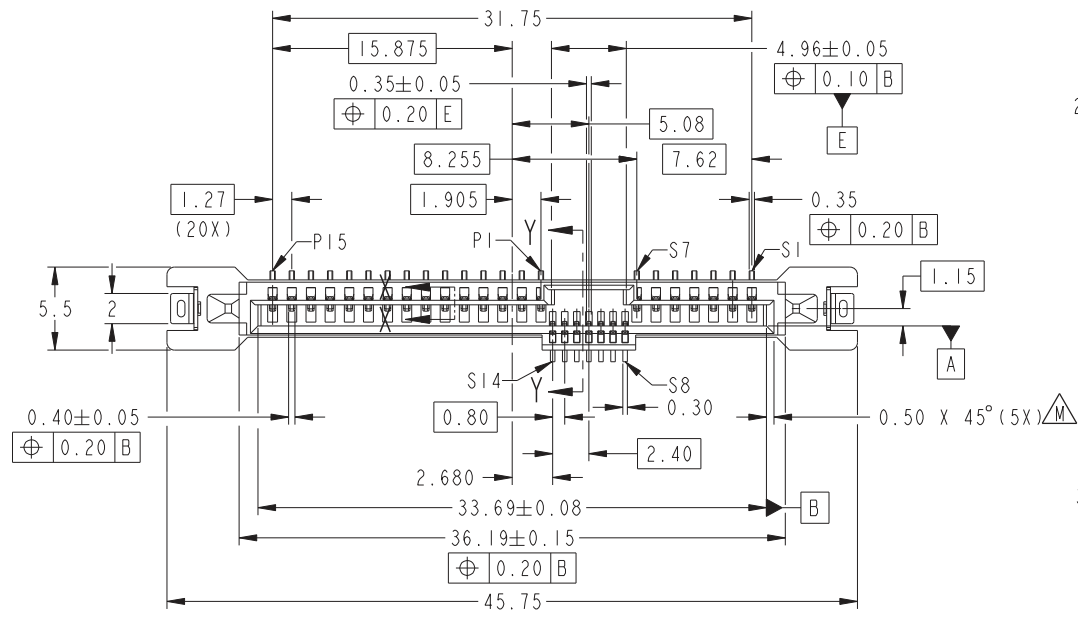

| | | | | | | | | | | |
|---------------------------------------|---------------------|------|---------|------------|------------|----|----------------|----------|-----------|-----|
| spec ref | - | dr | GL LOO | 2004-02-27 | projection | MM | size | A3 | scale | 3:1 |
| tolerance std | ISO 406 ISO 1101 | eng | GL LOO | 2004-02-27 | | | ecm no | S10-0228 | rel level | - |
| TOLERANCES UNLESS OTHERWISE SPECIFIED | | chr | GL LOO | 2010-10-28 | | | product family | SAS | rel level | - |
| surface | linear | appr | JOEY NG | 2010-10-28 | | | rel level | - | | |
| | angular | | | | | | | | | |

| | | | | | | | | | | |
|--|---|--------------|---|----------|-----------------------|------------|--------------|--------------------|----------------|----------|
| | SAS RECEPTACLE VERTICAL SMT TYPE ASSY | | title SAS RECEPTACLE VERTICAL SMT TYPE ASSY | cat. no. | product family SAS | size A3 | scale 3:1 | ecn no S10-0228 | rel level - | rev M |
| | spec ref - | dr GL LOO | | | | | | | | |

| 1 | | 2 | | | 3 | | 4 |
|--------------------|------------|---------|-------------|-------------|--------------|--------------------|--------|
| PRODUCT NO | METAL CLIP | PLATING | PICK-UP CAP | PACKAGING | REMARKS | PRODUCT NO | PLATNG |
| 10031567-001LF | 2 PCS | NOTE 2 | NO | TRAY | NOTE ⑧ | 10031567-401LF | NOTE ⑪ |
| 10031567-001CLF | | | YES | | NOTE ④ & ⑧ | 10031567-401CLF | |
| 10031567-001C-TRLF | | | YES | TAPE & REEL | NOTE ④ ⑥ & ⑧ | 10031567-401C-TRLF | |

NOTES:

1. MATERIAL :
 1) HOUSING : HIGH TEMP THERMOPLASTIC, UL 94V-0
 COLOR : BLACK
 2) TERMINAL : COPPER ALLOY
 3) HOLD DOWN : COPPER ALLOY
- ② FINISH :
 1) TERMINAL : 30μ" Au PLATING (CONTACT POINT) OVER 50μ" NICKEL
 2) SOLDER TAIL : 100μ" MIN Sn OVER 50μ" NICKEL
 3) HOLD DOWN : 100μ" MIN Sn OVER 50μ" NICKEL
3. PER SFF REV 1.1, EXCEPT 0.8mm PITCH BUMP AREA.
- ④ PART WITH PICK-UP CAP, P/N XXXXXXXX-XXX_C LF.
- ⑤ THE STD PACKAGING IS IN TRAY UNLESS OTHERWISE SPECIFIED.
- ⑥ PART NUMBER WITH SUFFIX "-TR" MEANS FOR TAPE & REEL PACKAGING (E.G. P/N: XXXXXXXX-XXX_C-TRLF).
7. THE HOUSING WILL WITHSTAND EXPOSURE TO 260°C PEAK TEMPERATURE FOR 10 SECONDS IN A CONVECTION, INFRA-RED OR VAPOR PHASE REFLOW OVEN.
- ⑧ THIS PRODUCT MEETS EUROPEAN UNION DIRECTIVES AND OTHER COUNTRY REGULATIONS AS DESCRIBED IN GS-22-008.
- ⑨ PART NUMBERS ENDING IN "LF" MEANS FOR NOTE 8 LEAD FREE IDENTIFICATION
~~(i) XXXXXXXX-XXXLF IS EQUIVALENT TO PREVIOUS P/N XXXXXXXX-XXX~~
~~(ii) XXXXXXXX-XXXCLF IS EQUIVALENT TO P/N XXXXXXXX-XXX_C~~
~~(iii) XXXXXXXX-XXX_C TRLF IS EQUIVALENT TO P/N XXXXXXXX-XXX_C TR~~
- ⑩ A Δ SYMBOL WILL BE NEXT TO ANY DIMENSION, VIEW, OR NOTE WHICH HAS BEEN MODIFIED WITH THE CURRENT DRAWING REVISION.
- ⑪ FINISH :
 1) TERMINAL : 15μ" GXT PLATING (CONTACT POINT) OVER 50μ" NICKEL
 2) SOLDER TAIL : 100μ" MIN Sn OVER 50μ" NICKEL
 3) HOLD DOWN : 100μ" MIN Sn OVER 50μ" NICKEL

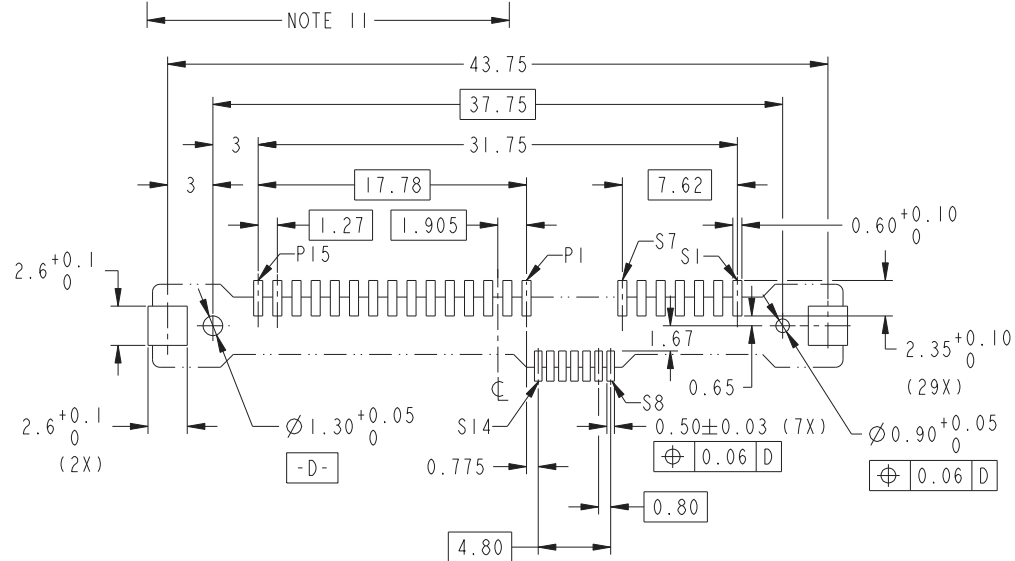

RECOMMENDED PCB LAYOUT

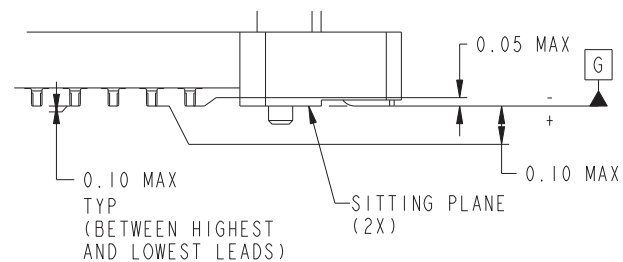

DETAIL 2
SCALE 6:1

| | | | | | | | | | | |
|---------------------------------------|---------------------|------|--------|------------|------------------------|----------|--------|--------------------|-----------|------------------------|
| spec ref | - | dr | GL LOO | 2004-02-27 | projection | MM | size | A3 | scale | 3:1 |
| tolerance std | ISO 406 ISO 1101 | eng | GL LOO | 2004-02-27 | | | ecn no | S10-0228 | rel level | - |
| TOLERANCES UNLESS OTHERWISE SPECIFIED | | chr | GL LOO | 2010-10-28 | | | | | | |
| surface | linear | 0.X | ±- | | SAS RECEPTACLE | | | dwg no 10031567 | rev M | |
| ISO 1302 | | 0.XX | ±0.20 | | VERTICAL SMT TYPE ASSY | | | | | |
| | angular | 0° | ±2° | | www.fci.com | cat. no. | - | | | Product - Customer Drw |



| 1 | | 2 | | | 3 | | 4 |
|--------------------|------------|---------|-------------|-------------|--------------|--------------------|---------|
| PRODUCT NO | METAL CLIP | PLATING | PICK-UP CAP | PACKAGING | REMARKS | PRODUCT NO | PLATING |
| 10031567-002LF | 1 PC | NOTE 2 | NO | TRAY | NOTE ⑧ | 10031567-402LF | NOTE ⑪ |
| 10031567-002CLF | | | YES | | NOTE ④ & ⑧ | 10031567-402CLF | |
| 10031567-002C-TRLF | | | YES | TAPE & REEL | NOTE ④ ⑥ & ⑧ | 10031567-402C-TRLF | |

NOTE 11

| PRODUCT NO | METAL CLIP | PLATING | PICK-UP CAP | PACKAGING | REMARKS |
|--------------------|------------|---------|-------------|-------------------------|--------------|
| 10031567-404C-TRLF | 1 PC | NOTE 11 | YES | CUSTOM-MADE TAPE & REEL | NOTE ④ ⑥ & ⑧ |

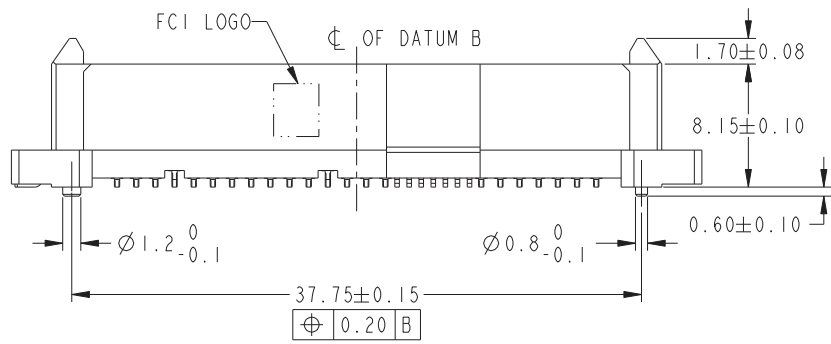
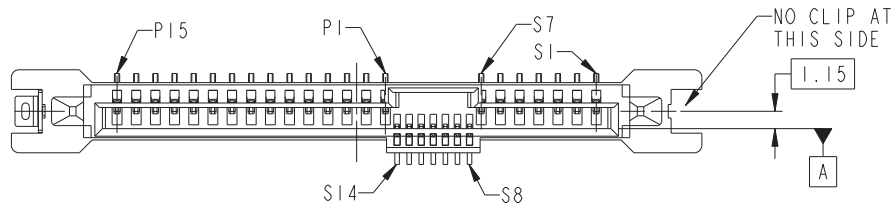

ALL OTHER DIMENSIONS, REFER TO SHEET 1.

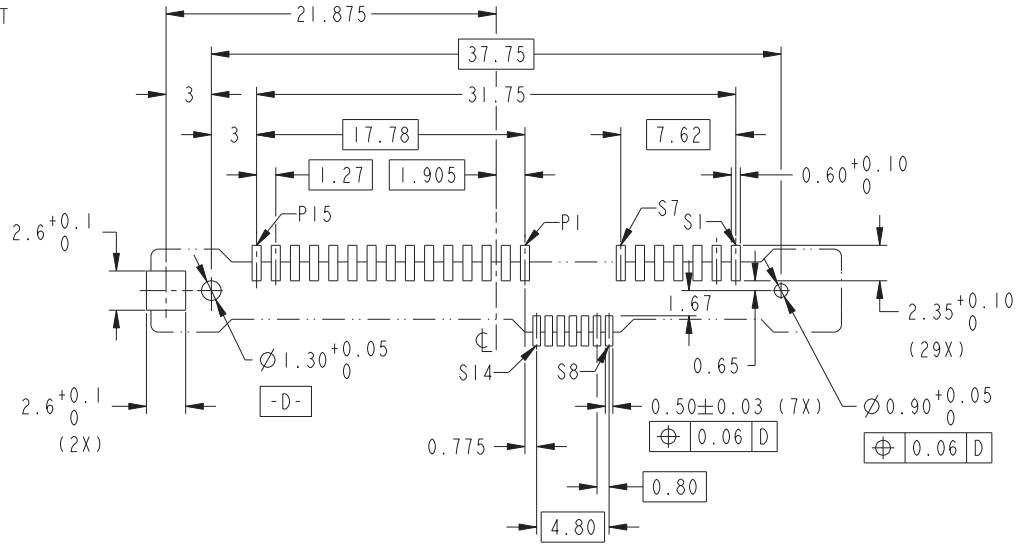

RECOMMENDED PCB LAYOUT

Copyright FCI.

| | | | | | | | | | | |
|---------------------------------------|---------------------|-------------|----------|------------|---|----|---------------------------|-----------------|-----------|-----|
| spec ref | - | dr | GL LOO | 2004-02-27 | projection | MM | size | A3 | scale | 3:1 |
| tolerance std | ISO 406 ISO 1101 | eng | GL LOO | 2004-02-27 | | | ecm no | S10-0228 | rel level | - |
| TOLERANCES UNLESS OTHERWISE SPECIFIED | | chr | GL LOO | 2010-10-28 | | | product family | SAS | rel level | - |
| surface | linear | 0.X | ±- | | SAS RECEPTACLE VERTICAL SMT TYPE ASSY | | dwg no 10031567 | rev M | | |
| | linear | 0.XX | ±0.20 | | | | | | | |
| | angular | 0° | ±2° | | | | | | | |
| ISO 1302 | | www.fci.com | cat. no. | - | Product - Customer Drw | | sheet 3 of 3 | | | |