

Technical Data Sheet

TOKIN Corporation

RoHS-2 compliant

Halogen Free

<Specifications>

Parts name	Inductance [nH]	DCR [mΩ]	I _{SAT1} [A]	I _{SAT2} [A]	I _{SAT3} [A]	I _{RMS} [A]
TPI078060L047N	47±10%	0.31±10%	90	83	73	53
TPI078060L056N	56±10%	0.31±10%	81	74	64	53
TPI078060L068N	68±10%	0.31±10%	69	63	55	53
TPI078060L082N	82±10%	0.31±10%	54	51	43	53

General Specifications

- I_{SAT1} : Peak current for approximately 20% rolloff at +25°C
- I_{SAT2} : Peak current for approximately 20% rolloff at +60°C
- I_{SAT3} : Peak current for approximately 20% rolloff at +100°C
- I_{RMS} : DC current for an approximate temperature rise of 40°C without core loss.

Electrical Requirement Note

- OCL : at 100kHz, 0.1Vrms, 0A, at 25°C
- DCR : at 20°C

DCR inspection position

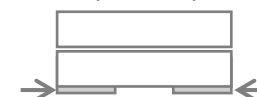

Environmental data

Operating temperature range : -40°C to +125°C (ambient plus self-temperature rise)

<DC-superimposed Characteristics>

Model: TPI078060L047N

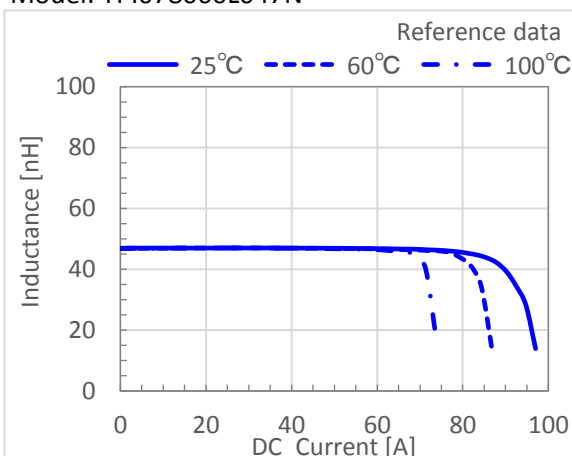

Model: TPI078060L056N

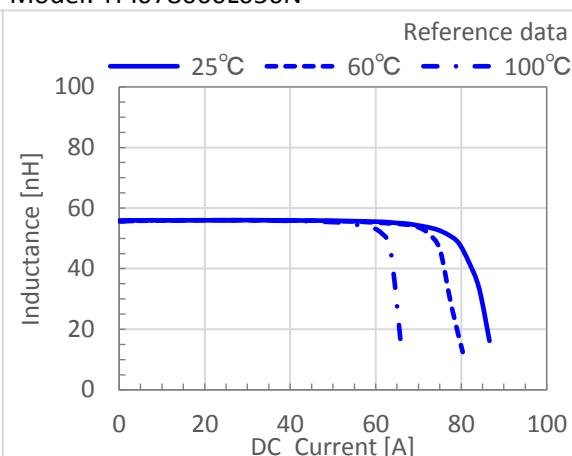

Model: TPI078060L068N

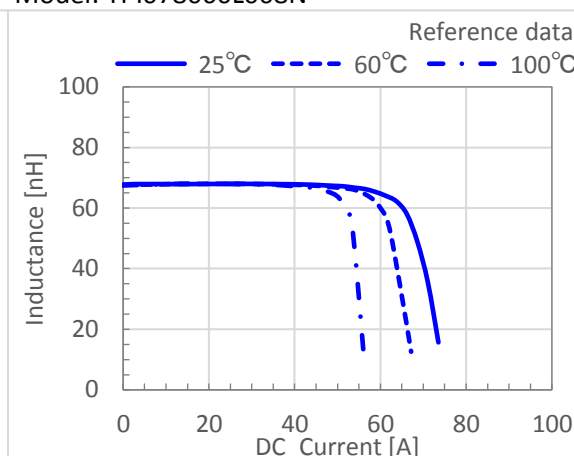

Model: TPI078060L082N

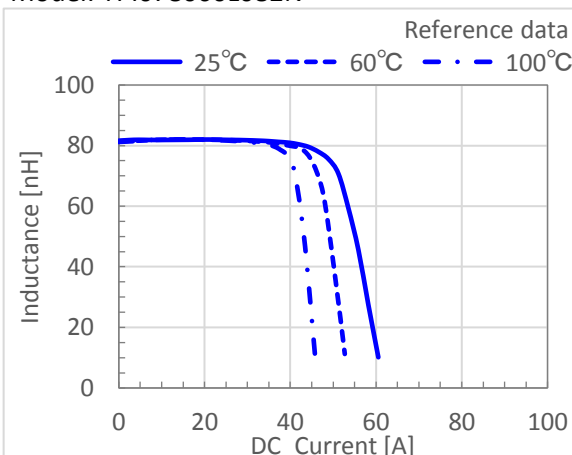

<Temperature-rise vs. DC current Characteristics>

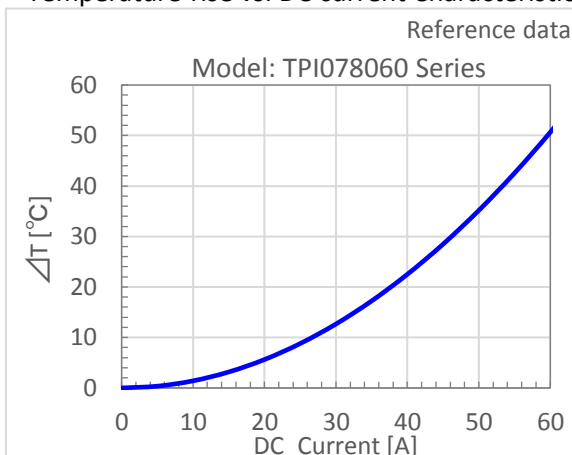

<Dimensions>

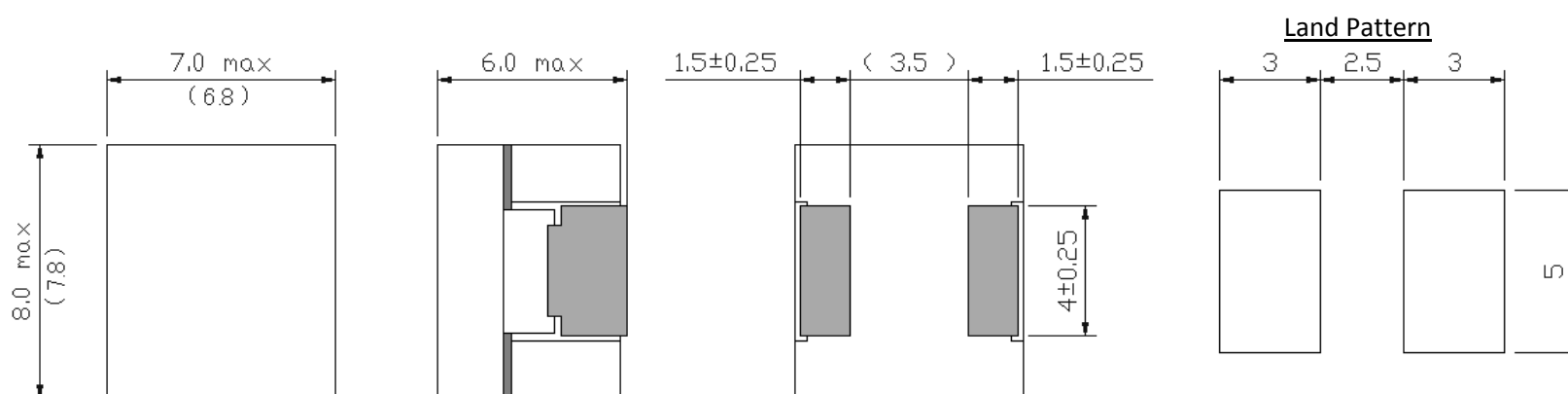

unit: mm

Recommended Reflow Soldering Profile

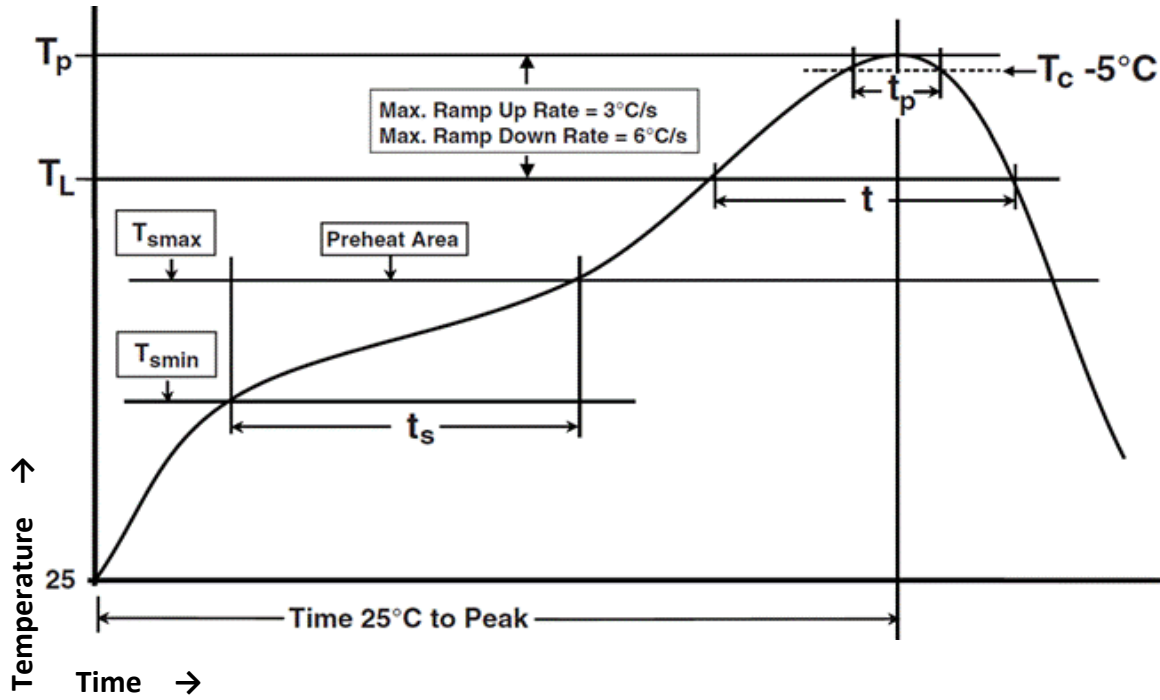

Table 1 Pb-Free Process classification temperature (T_c)

Package Thickness	Volume mm ³		
	<350	350 - 2000	>2000
<1.6mm	260°C	260°C	260°C
1.6 – 2.5mm	260°C	250°C	245°C
>2.5mm	250°C	245°C	245°C

Reference ICP/JEDEC J-STD-020E

Preheat and Soak	
Temperature min. (T_s min)	150°C
Temperature max. (T_s max)	200°C
Time (t_s) from (T_s min to T_s max)	60-120 seconds
Ramp up rate (T_s max to T_p)	3°C/ second max.
Liquidous temperature (T_L)	217°C
Time (t_l) maintained above T_L	60-150 seconds
Peak package body temperature (T_p max)	Table 1
Time (t_p max) within 5 °C of the specified classification temperature (T_c)	30 seconds
Ramp-down rate (T_p to T_s max)	6°C/ second max.
Time 25°C to Peak Temperature	8 minutes max.

- *1 The TPI078060-Series shape becomes 「package thickness >2.5mm」 「volume <350mm³」.
- *2 Leave more than 30 minutes after reflow.
- *3 Above reflow soldering profile is recommended. In case of using any other reflow profile, please make sure it shall be tested and confirmed in advance, to prevent any problem caused by incomplete soldering or the part be damaged.
- *4 Reflow guaranteed no more than 2 times.

Embossed carrier tape packaging

1. Embossed carrier tape dimensions

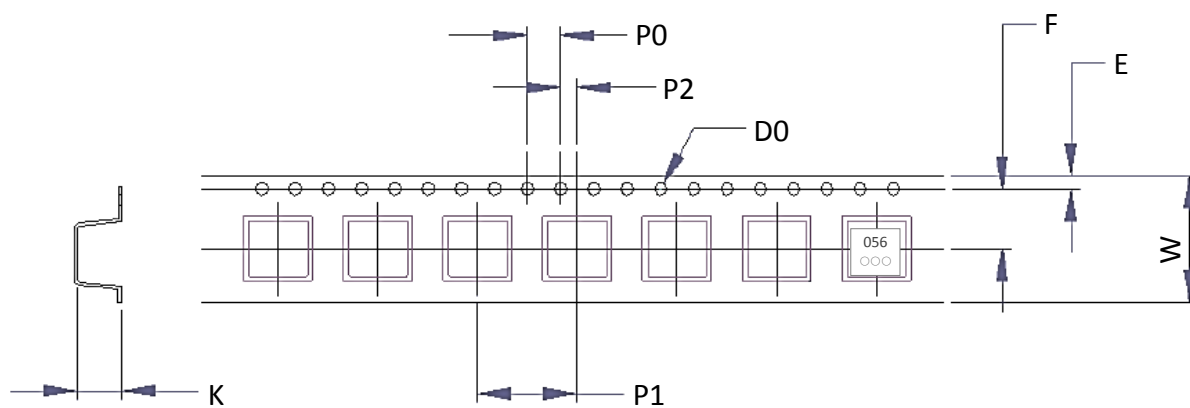

- W: 16.0
 - F: 7.5
 - E: 1.75
 - K: 6.3
 - P0: 4.0
 - P1: 12.0
 - P2: 2.0
 - D0: φ1.55
- (unit:mm)

Appendix 2

2. Reel dimensions

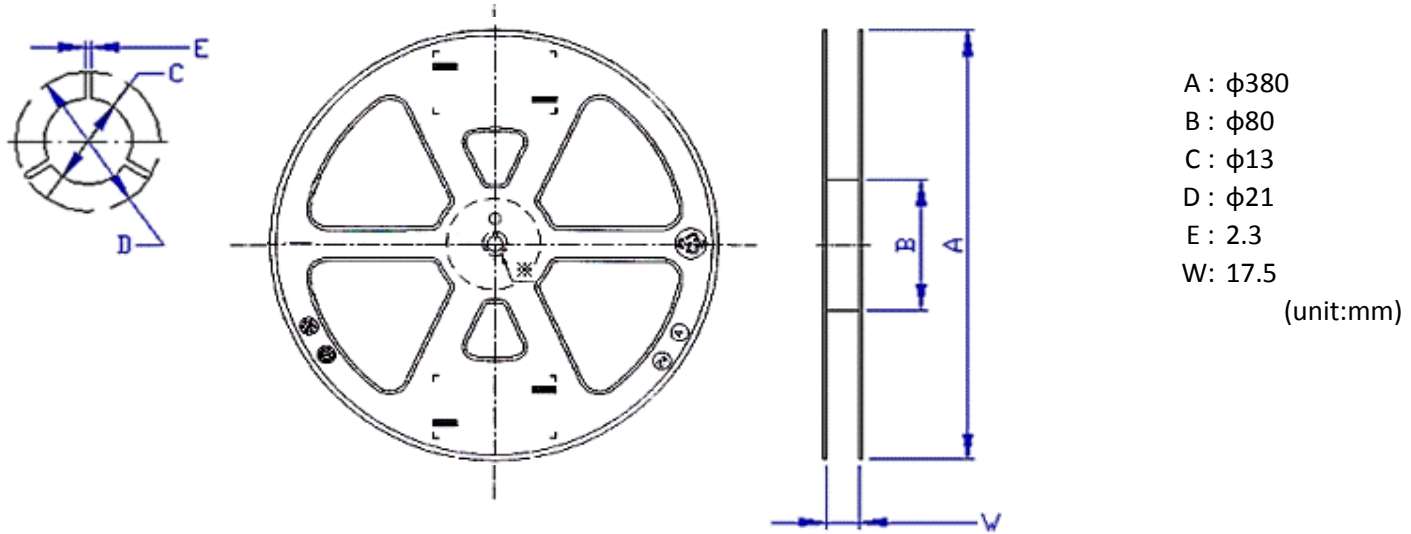

3. Leader and trailer tape

Quantity

The standard quantity of the product contained in reel is 1000 pcs.

Package form

The beginning (Leader part) of the carrier-tape and an end (trailer part) has blank part where there's no product contained.

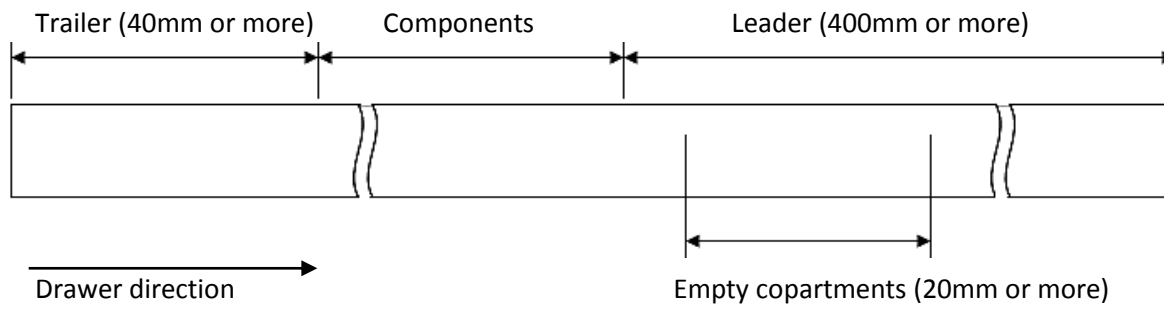

Packing

1. Labeling on the reel

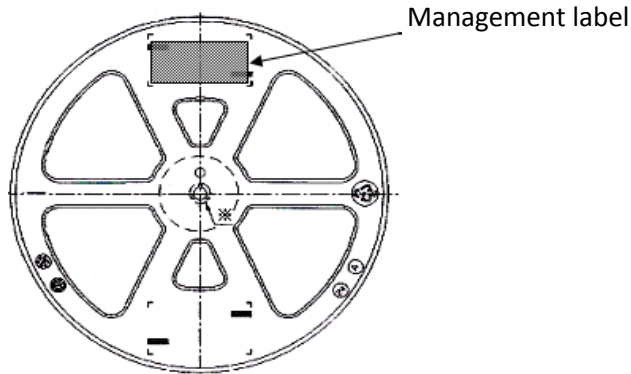

2. Standard outside package

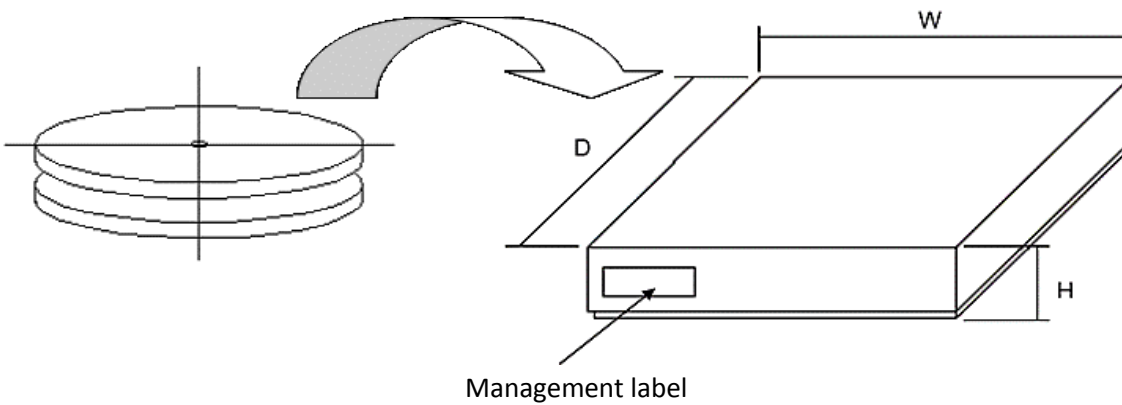

Packing Quantity (One box) : 2000pcs (1000pcs/reel \times 2)

Outside package size : W: 450 \times D: 450 \times H: 80 (unit: mm)