



LOW-VOLTAGE 20-BIT BUS SWITCH

IDT74CBTLV16210

FEATURES:

- 5Ω A/B bi-directional switch
- Isolation Under Power-Off Conditions
- Over-voltage tolerant
- Latch-up performance exceeds 100mA
- VCC = 2.3V - 3.6V, normal range
- ESD >2000V per MIL-STD-883, Method 3015; >200V using machine model (C = 200pF, R = 0)
- Available in TSSOP package

APPLICATIONS:

- 3.3V High Speed Bus Switching and Bus Isolation

DESCRIPTION:

The CBTLV16210 operates as a single 20-bit bus switch or as a dual 10-bit bus switch, which provides high-speed switching. This device has very low ON resistance, resulting in under 250ps propagation delay through the switch. When Output Enable (\overline{OE}) is low, the corresponding 10-bit bus switch is on and port A is connected to Port B. When \overline{OE} is high, the switch is off and a high impedance exists between Port A and Port B.

To ensure the high-impedance state during power up or power down, \overline{OE} should be tied to VCC through a pullup resistor.

FUNCTIONAL BLOCK DIAGRAM

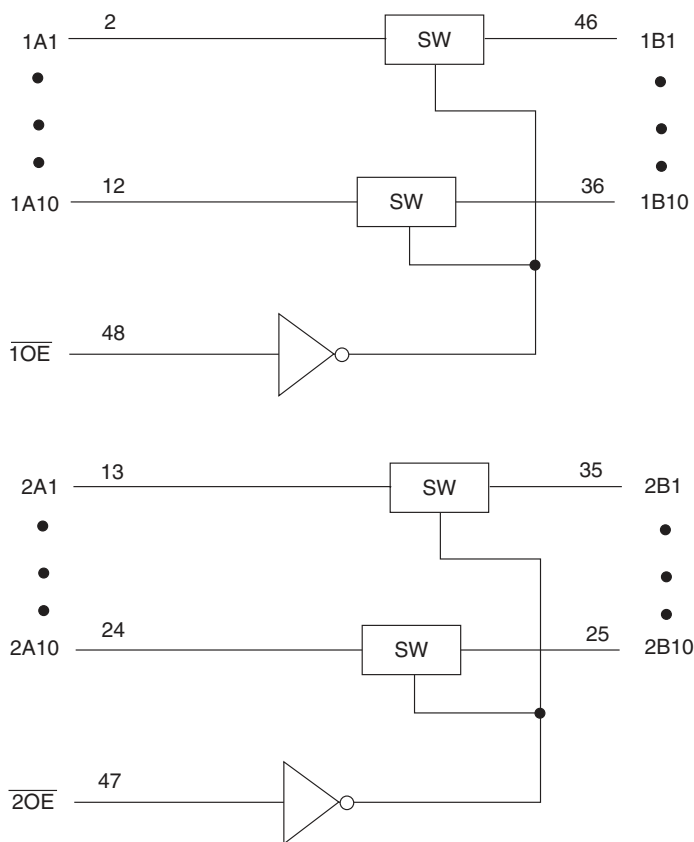

SIMPLIFIED SCHEMATIC, EACH SWITCH

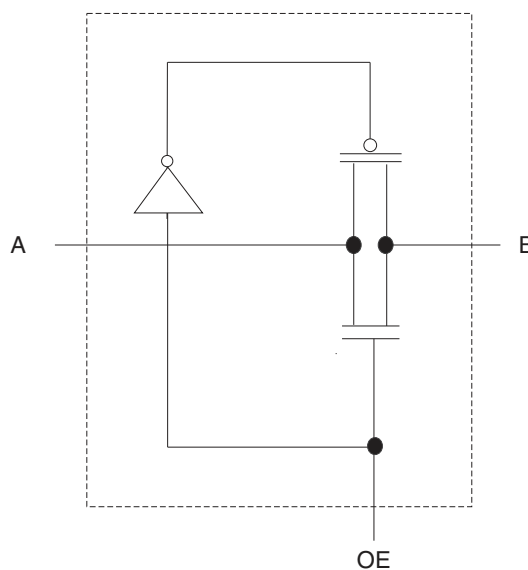

The IDT logo is a registered trademark of Integrated Device Technology, Inc.

INDUSTRIAL TEMPERATURE RANGE

DECEMBER 2014

PIN CONFIGURATION

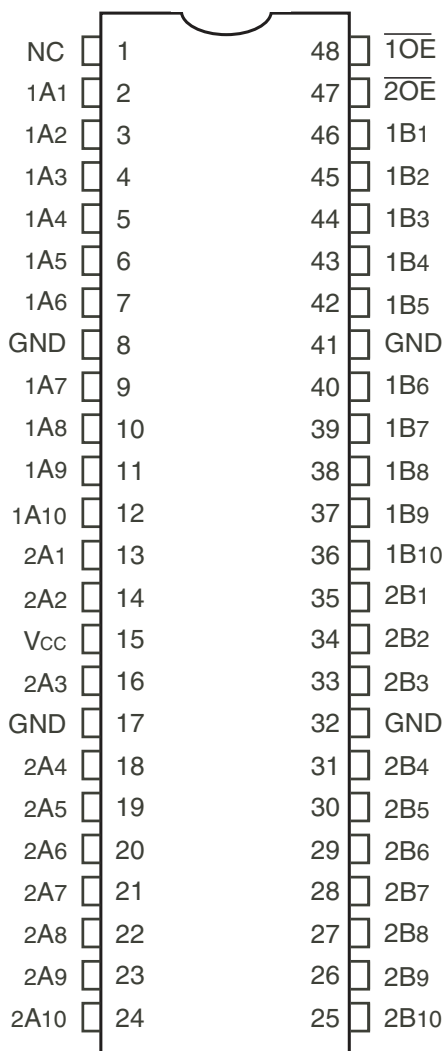

TSSOP
TOP VIEW

ABSOLUTE MAXIMUM RATINGS⁽¹⁾

| Symbol | Description | Max. | Unit |
|------------------|---|-------------|------|
| V _{CC} | Supply Voltage Range | -0.5 to 4.6 | V |
| V _I | Input Voltage Range | -0.5 to 4.6 | V |
| | Continuous Channel Current | 128 | mA |
| I _{IK} | Input Clamp Current, V _{I/O} < 0 | -50 | mA |
| T _{STG} | Storage Temperature Range | -65 to +150 | °C |

NOTE:

- Stresses greater than those listed under ABSOLUTE MAXIMUM RATINGS may cause permanent damage to the device. This is a stress rating only and functional operation of the device at these or any other conditions above those indicated in the operational sections of this specification is not implied. Exposure to absolute maximum rating conditions for extended periods may affect reliability.

PIN DESCRIPTION

| Pin Names | Description |
|------------------|----------------------------|
| \overline{xOE} | Output Enable (Active LOW) |
| xAx | Port A Inputs or Outputs |
| xBx | Port B Inputs or Outputs |

FUNCTION TABLE⁽¹⁾

| Input | Operation |
|-----------------|-----------------|
| \overline{OE} | |
| L | A-Port = B-Port |
| H | Disconnect |

NOTE:

- H = HIGH Voltage Level
L = LOW Voltage Level

OPERATING CHARACTERISTICS⁽¹⁾

| Symbol | Parameter | Test Conditions | Min. | Max. | Unit |
|-----------------|----------------------------------|--------------------------------|------|------|------|
| V _{CC} | Supply Voltage | | 2.3 | 3.6 | V |
| V _{IH} | High-Level Control Input Voltage | V _{CC} = 2.3V to 2.7V | 1.7 | — | V |
| | | V _{CC} = 2.7V to 3.6V | 2 | — | |
| V _{IL} | Low-Level Control Input Voltage | V _{CC} = 2.3V to 2.7V | — | 0.7 | V |
| | | V _{CC} = 2.7V to 3.6V | — | 0.8 | |
| T _A | Operating Free-Air Temperature | | -40 | +85 | °C |

NOTE:

- All unused control inputs of the device must be held at V_{CC} or GND to ensure proper device operation.

DC ELECTRICAL CHARACTERISTICS OVER OPERATING RANGE

Following Conditions Apply Unless Otherwise Specified:

Operating Condition: TA = -40°C to +85°C

| Symbol | Parameter | Test Conditions | Min. | Typ. ⁽¹⁾ | Max. | Unit | |
|---------------------------------|--|---|-----------------------|-----------------------|------|------|---|
| V _{IK} | Control Inputs, Data I/O | V _{CC} = 3V, I _I = -18mA | — | — | -1.2 | V | |
| I _I | Control Inputs | V _{CC} = 3.6V, V _I = V _{CC} or GND | — | — | ±1 | μA | |
| I _{OZ} | Data I/O | V _{CC} = 3.6V, V _O = 0V or 3.6V switch disabled | — | — | 5 | μA | |
| I _{OFF} | | V _{CC} = 0V, V _I or V _O = 0V or 3.6V | — | — | 10 | μA | |
| I _{CC} | | V _{CC} = 3.6V, I _O = 0, V _I = V _{CC} or GND | — | — | 10 | μA | |
| ΔI _{CC} ⁽²⁾ | Control Inputs | V _{CC} = 3.6V, one input at 3V, other inputs at V _{CC} or GND | — | — | 300 | μA | |
| C _I | Control Inputs | V _I = 3V or 0 | — | 4 | — | pF | |
| C _{I(OFF)} | | V _O = 3V or 0, \overline{OE} = V _{CC} | — | 6.5 | — | pF | |
| R _{ON} ⁽³⁾ | Max. at V _{CC} = 2.3V Typ. at V _{CC} = 2.5V | V _I = 0 | I _O = 64mA | — | 5 | 8 | Ω |
| | | | I _O = 24mA | — | 5 | 8 | |
| | V _{CC} = 3V | V _I = 1.7V | I _O = 15mA | — | 27 | 40 | |
| | | | V _I = 0 | I _O = 64mA | — | 5 | |
| | | V _I = 2.4V | | I _O = 24mA | — | 5 | |
| | | | I _O = 15mA | — | 10 | 15 | |

NOTES:

1. Typical values are at 3.3V, +25°C ambient.
2. The increase in supply current is attributable to each input that is at the specified voltage level rather than V_{CC} or GND.
3. This is measured by the voltage drop between the A and B terminals at the indicated current through the switch.

SWITCHING CHARACTERISTICS

| Symbol | Parameter | V _{CC} = 2.5V ± 0.2V | | V _{CC} = 3.3V ± 0.3V | | Unit |
|--------------------------------|--|-------------------------------|------|-------------------------------|------|------|
| | | Min. | Max. | Min. | Max. | |
| t _{PD} ⁽¹⁾ | Propagation Delay A to B or B to A | — | 0.15 | — | 0.25 | ns |
| t _{EN} | Output Enable Time \overline{OE} to A or B | 1 | 6.8 | 1 | 6 | ns |
| t _{DIS} | Output Disable time \overline{OE} to A or B | 1 | 7.3 | 1 | 7.4 | ns |

- NOTE:
1. The propagation delay is the calculated RC time constant of the typical on-state resistance of the switch and the specified load capacitance when driven by an ideal voltage source (zero output impedence).

TEST CIRCUITS AND WAVEFORMS

TEST CONDITIONS

| Symbol | $V_{CC}^{(1)}=3.3V\pm 0.3V$ | $V_{CC}^{(2)}=2.5V\pm 0.2V$ | Unit |
|------------|-----------------------------|-----------------------------|------|
| V_{LOAD} | $2 \times V_{CC}$ | $2 \times V_{CC}$ | V |
| V_{IH} | 3 | V_{CC} | V |
| V_T | 1.5 | $V_{CC} / 2$ | V |
| V_{LZ} | 300 | 150 | mV |
| V_{HZ} | 300 | 150 | mV |
| C_L | 50 | 30 | pF |

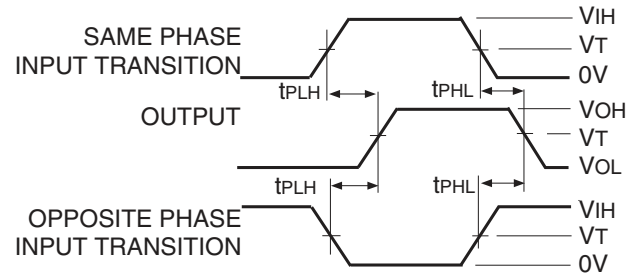

Propagation Delay

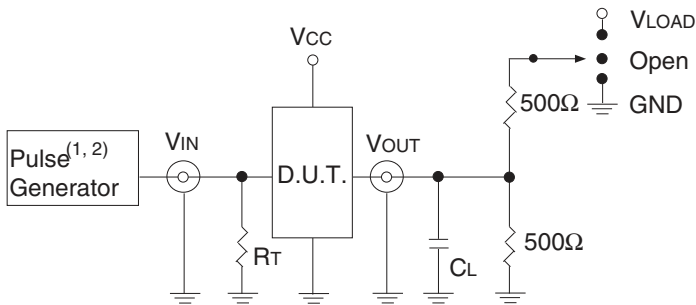

Test Circuits for All Outputs

DEFINITIONS:

C_L = Load capacitance: includes jig and probe capacitance.
 R_T = Termination resistance: should be equal to Z_{OUT} of the Pulse Generator.

NOTES:

1. Pulse Generator for All Pulses: Rate $\leq 10\text{MHz}$; $t_r \leq 2.5\text{ns}$; $t_f \leq 2.5\text{ns}$.
2. Pulse Generator for All Pulses: Rate $\leq 10\text{MHz}$; $t_r \leq 2\text{ns}$; $t_f \leq 2\text{ns}$.

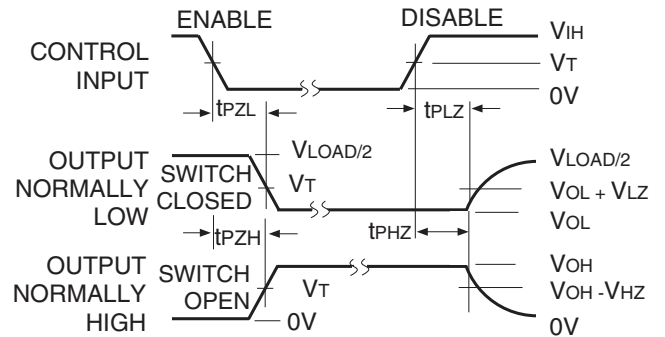

NOTE:

1. Diagram shown for input Control Enable-LOW and input Control Disable-HIGH.

Enable and Disable Times

SWITCH POSITION

| Test | Switch |
|-------------------|------------|
| t_{PLZ}/t_{PZL} | V_{LOAD} |
| t_{PHZ}/t_{PZH} | GND |
| t_{PD} | Open |

ORDERING INFORMATION

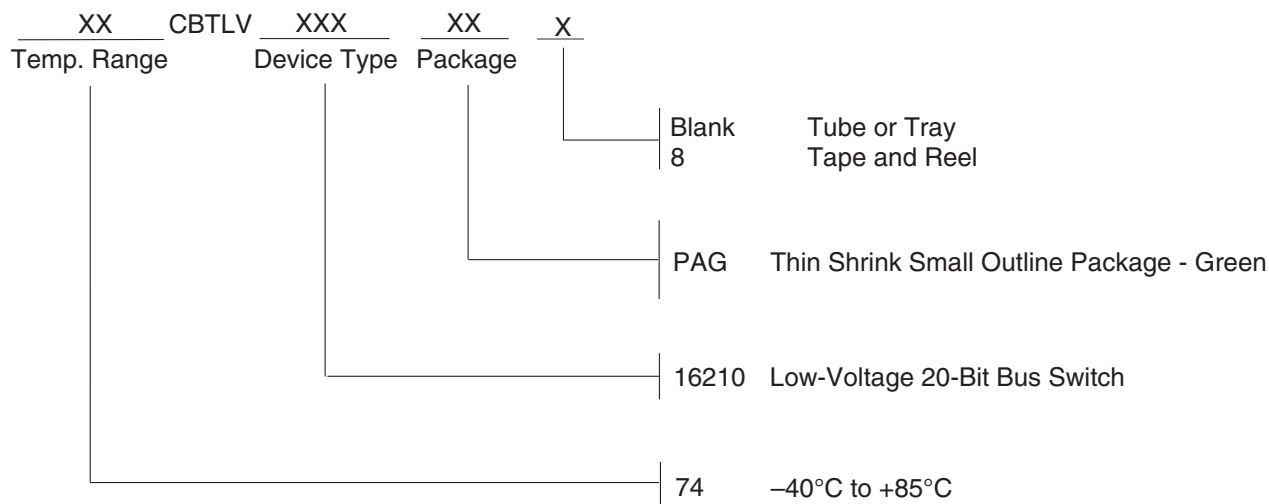

Datasheet Document History

12/01/2014 Pg. 5 Updated the ordering information by adding Tape and Reel information.



CORPORATE HEADQUARTERS
6024 Silver Creek Valley Road
San Jose, CA 95138

for SALES:
800-345-7015 or 408-284-8200
fax: 408-284-2775
www.idt.com

for Tech Support:
logichelp@idt.com