

REFERENCE SPECIFICATIONS

-NFC 93425 (in compliance with HE 507)

PHYSICAL CHARACTERISTICS

- INSULATOR MATERIAL: THERMOPLASTIC UL94V0
- CONTACT MATERIAL: BRASS
- ACCESSORIES: BRASS
- SHELLS: STEEL

ELECTRICAL CHARACTERISTICS

- NOMINAL CURRENT: 30A or 40A
- CONTACT RESISTANCE: 7.3 m ohms
- CONTACT/CONTACT : 1000 V
- CONTACT/GROUND : 1200 V
- INSULATION RESISTANCE: 5000 MOhms

ENVIRONMENTAL CHARACTERISTICS

- CLIMATIC CATEGORY: 55/125/21
- TEMPERATURE RANGE -55°C TO +125°C
- DAMP HEAT STEADY STATE 21 DAYS
- SALT SPRAY 24 HOURS

MECHANICAL CHARACTERISTICS

- RETENTION AGAINST TORQUE: - Threaded insert: 0.7 N.m maximum
- Female screw : 0.5 N.m maximum

NOTE RoHS INFORMATION

- The "LF" products meet european union Directives and other country regulations as described in GS-47-0004.
- The housing will withstand exposure to 260°C peak temperature for 3.5 seconds in a wave solder application with a 1.6mm minimum thick circuit board. See application notes/procedures if they are available.
- Termination plating spec:
  - Ni 1.27µmi+Sn 2.5 to 7.5µ(pure bright)
- Active area plating spec:
  - Ni + Gold/GxT
- Shell plating :2 to 4µm Cu +Ni+3 to 10µmm Sn(pure bright)
- Accessories: Sn pure bright+Ni
- Packaging spec: See GS-14-920

# DBL5W5S300G30LF

Series

Shell size: **E A B C**

see sheet 2

Front accessory definition see sheet 2

- L** : threaded insert M3
- O** : threaded insert UNC 4-40
- V** : female screw UNC 4-40

Layout of contacts (see sheet 3)

Contacts

- S** : Socket

Termination type

- 3** Straight version

Plating

- 00** 200 matings/unmatings
- 43** 500 matings/unmatings

PCB accessories definition see sheet 2

- H** : harpoons for PCB 2.40mm
- G** : harpoons for PCB 1.60mm

Power contacts

- 30** : Fitted with power contacts 30 Amp.
- 40** : Fitted with power contacts 40 Amp.

See note RoHS

TABLE 1:PCB HOLE DIAMETERS

POWER CONTACTS			ACCESSORIES
30 A	2.00	ø2.40	ø3.10
40 A	2.80	3.10	
Max current power	ØA±0.1	PCB HOLE +/-0.1	PCB HOLE +/-0.1

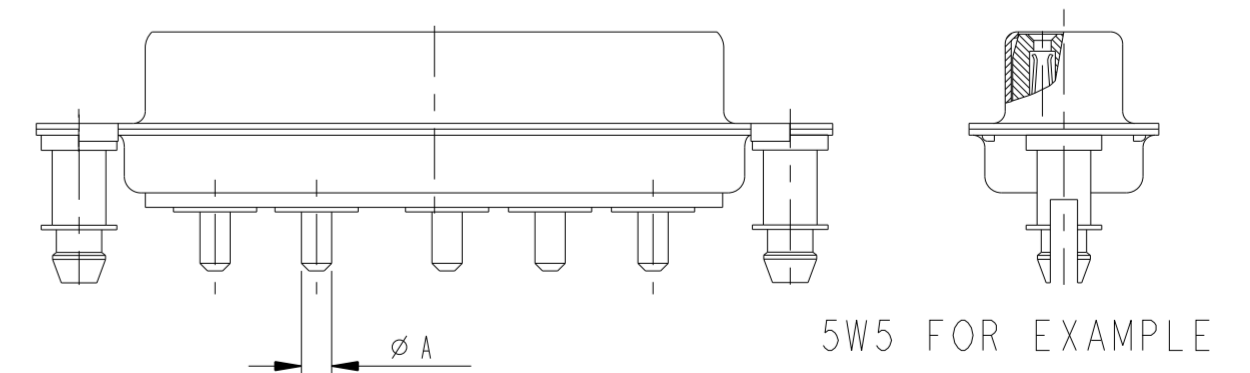

spec ref	dr	1, Product Eng	2015/06/12	projection	MM	size	A2	scale	3:1
tolerance std	eng	Paul Mithun	2019/08/29			ecn no	ELX-33136-1	rel level	Released
ISO 406	chr	-							
ISO 1101	appr	Varma Sudhir	2019/09/03						
surface	linear	<b>Amphenol FCI</b>		product family		cat. no.		Product - Customer Drw	sheet 1 of 4
ISO 1302	angular	0°	±2°	title	SUB FEMALE DW	cat. no.		Product - Customer Drw	sheet 1 of 4
		0.X	±0.3	full power straight solder		cat. no.		Product - Customer Drw	sheet 1 of 4
		0.XX	±0.1			cat. no.		Product - Customer Drw	sheet 1 of 4
		0.XXX	±0.05			cat. no.		Product - Customer Drw	sheet 1 of 4
						cat. no.		Product - Customer Drw	sheet 1 of 4

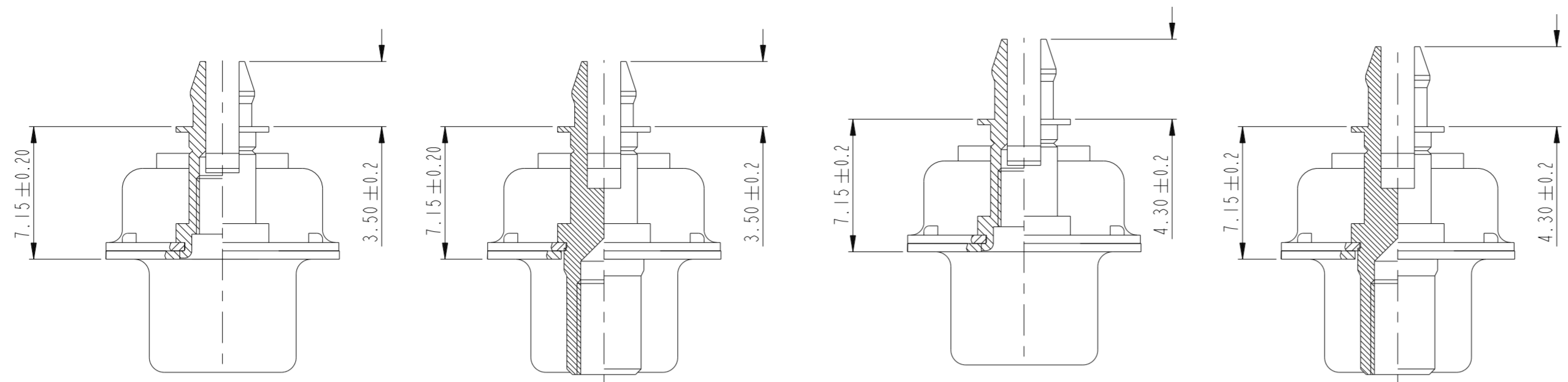

FRONT ACCESSORY	<b>L</b> insert M3 <b>O</b> insert UNC 4.40	<b>V</b> insert UNC 4.40	<b>L</b> insert M3 <b>O</b> insert UNC 4.40	<b>V</b> insert UNC 4.40
PCB ACCESSORIES	<b>G</b> Harpoon for PCB 1.60mm	<b>G</b> Harpoon for PCB 1.60mm	<b>H</b> Harpoon for PCB 2.40mm	<b>H</b> Harpoon for PCB 2.40mm

PART NUMBER	AMPS	MATINGS/ UNMATINGS	FRONT ACCESSORY	PCB ACCESSORIES
D*LxWxS300G30LF	30	200	insert M3	harpoon PCB 1.60mm
D*OxWxS300G30LF	30	200	insert UNC 4.40	harpoon PCB 1.60mm
D*VxWxS300G30LF	30	200	female screw UNC 4.40	harpoon PCB 1.60mm
D*LxWxS300H30LF	30	200	insert M3	harpoon PCB 2.40mm
D*OxWxS300H30LF	30	200	insert UNC 4.40	harpoon PCB 2.40mm
D*VxWxS300H30LF	30	200	female screw UNC 4.40	harpoon PCB 2.40mm
D*LxWxS300G40LF	40	200	insert M3	harpoon PCB 1.60mm
D*OxWxS300G40LF	40	200	insert UNC 4.40	harpoon PCB 1.60mm
D*VxWxS300G40LF	40	200	female screw UNC 4.40	harpoon PCB 1.60mm
D*LxWxS300H40LF	40	200	insert M3	harpoon PCB 2.40mm
D*OxWxS300H40LF	40	200	insert UNC 4.40	harpoon PCB 2.40mm
D*VxWxS300H40LF	40	200	female screw UNC 4.40	harpoon PCB 2.40mm

shell size \* LAYOUTS  
 E 2V2  
 A 3V3  
 A 3W3  
 B 5W5  
 C 8W8

PART NUMBER	AMPS	MATINGS/ UNMATINGS	FRONT ACCESSORY	PCB ACCESSORIES
D*LxWxS343G30LF	30	500	insert M3	harpoon PCB 1.60mm
D*OxWxS343G30LF	30	500	insert UNC 4.40	harpoon PCB 1.60mm
D*VxWxS343G30LF	30	500	female screw UNC 4.40	harpoon PCB 1.60mm
D*LxWxS343H30LF	30	500	insert M3	harpoon PCB 2.40mm
D*OxWxS343H30LF	30	500	insert UNC 4.40	harpoon PCB 2.40mm
D*VxWxS343H30LF	30	500	female screw UNC 4.40	harpoon PCB 2.40mm
D*LxWxS343G40LF	40	500	insert M3	harpoon PCB 1.60mm
D*OxWxS343G40LF	40	500	insert UNC 4.40	harpoon PCB 1.60mm
D*VxWxS343G40LF	40	500	female screw UNC 4.40	harpoon PCB 1.60mm
D*LxWxS343H40LF	40	500	insert M3	harpoon PCB 2.40mm
D*OxWxS343H40LF	40	500	insert UNC 4.40	harpoon PCB 2.40mm
D*VxWxS343H40LF	40	500	female screw UNC 4.40	harpoon PCB 2.40mm

Amphenol FCI

© 2016 APCI

spec ref	dr 1, Product Eng	2015/06/12	projection	MM	size A2	scale 1:1	
tolerance std	eng Paul Mithun	2019/08/29			ecn no ELX-33136-1	rel level Released	
ISO 406 ISO 1101	chr -	-					product family
TOLERANCES UNLESS OTHERWISE SPECIFIED	appr Varma Sudhir	2019/09/03	<b>Amphenol FCI</b>		title SUB FEMALE DW full power straight solder	rev G C01-8639-2310 ptc_wm	
surface	linear	0.X ±0.3 0.XX ±0.1 0.XXX ±0.05	angular	0° ±2°	cat. no.	Product - Customer Drw	sheet 2 of 4

PDS: Rev :G

STATUS:Released

Printed: Sep 03, 2019

2V2

LAYOUT AND CONNECTOR DIMENSIONS

For PCB hole diameters see table I sheet 1

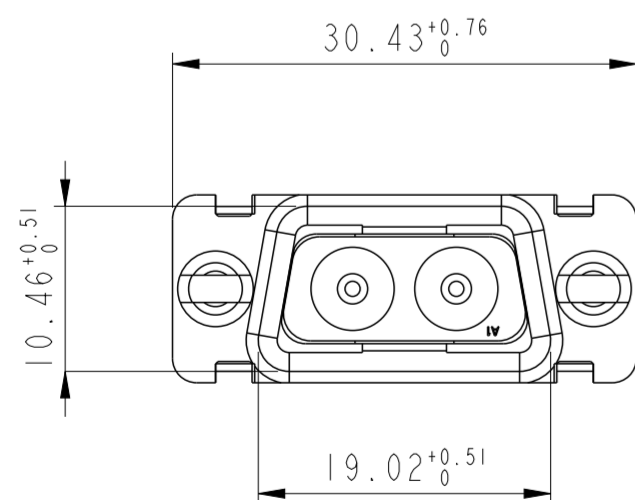
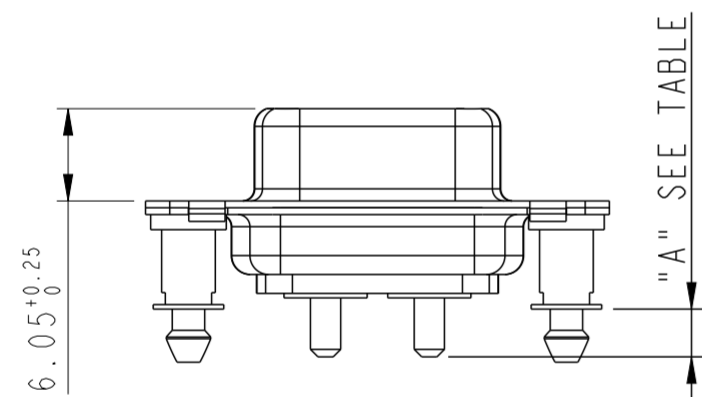
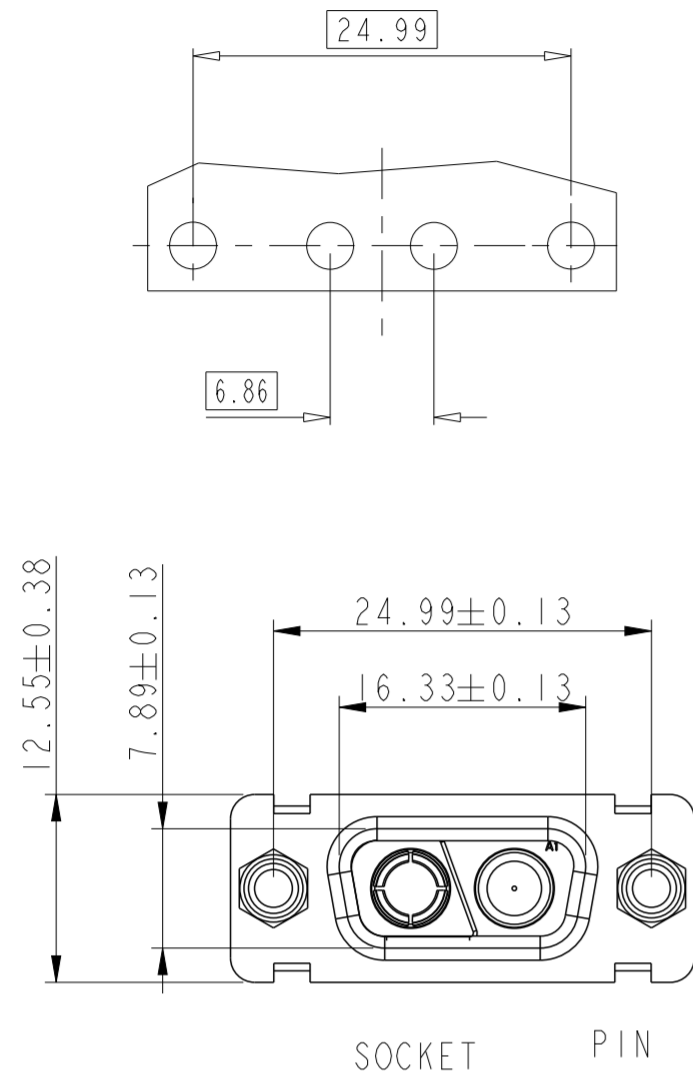

3V3

LAYOUT AND CONNECTOR DIMENSIONS

For PCB hole diameters see table I sheet 1

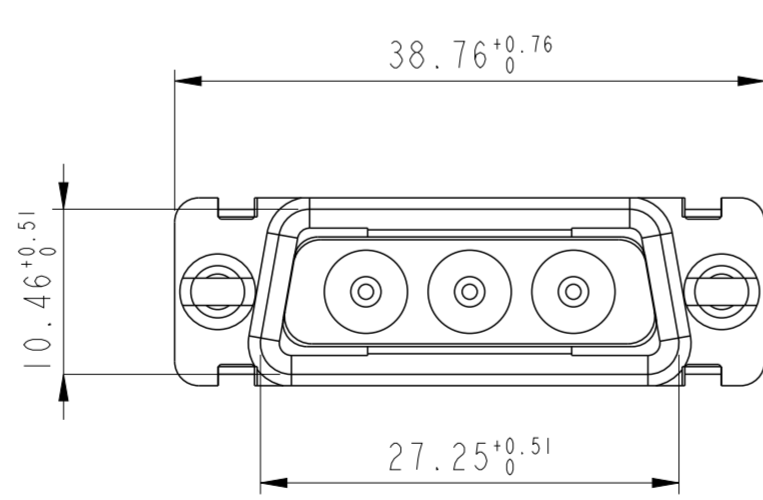
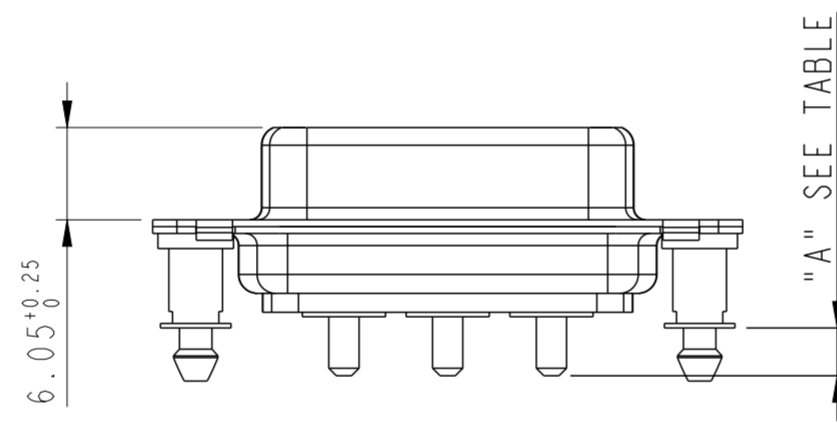
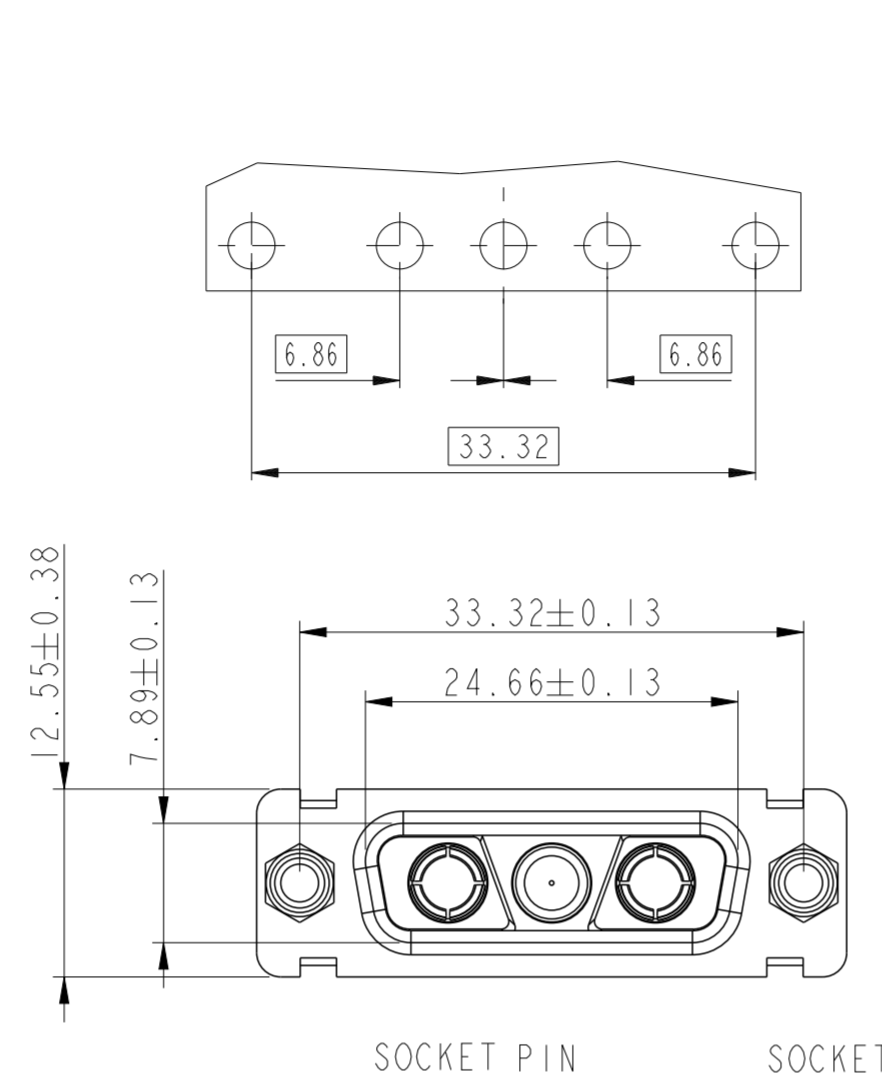

3W3

LAYOUT AND CONNECTOR DIMENSIONS

For PCB hole diameters see table I sheet 1

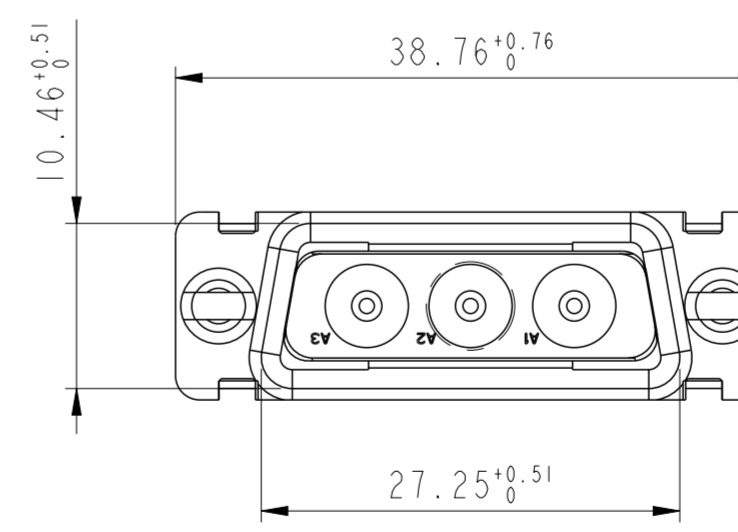
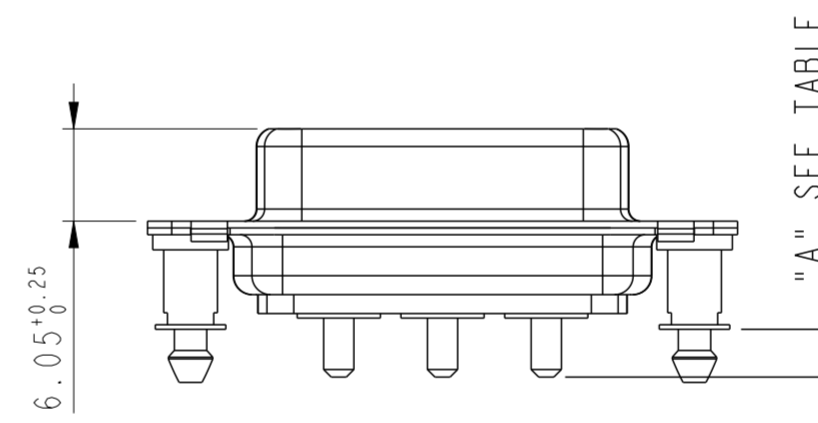
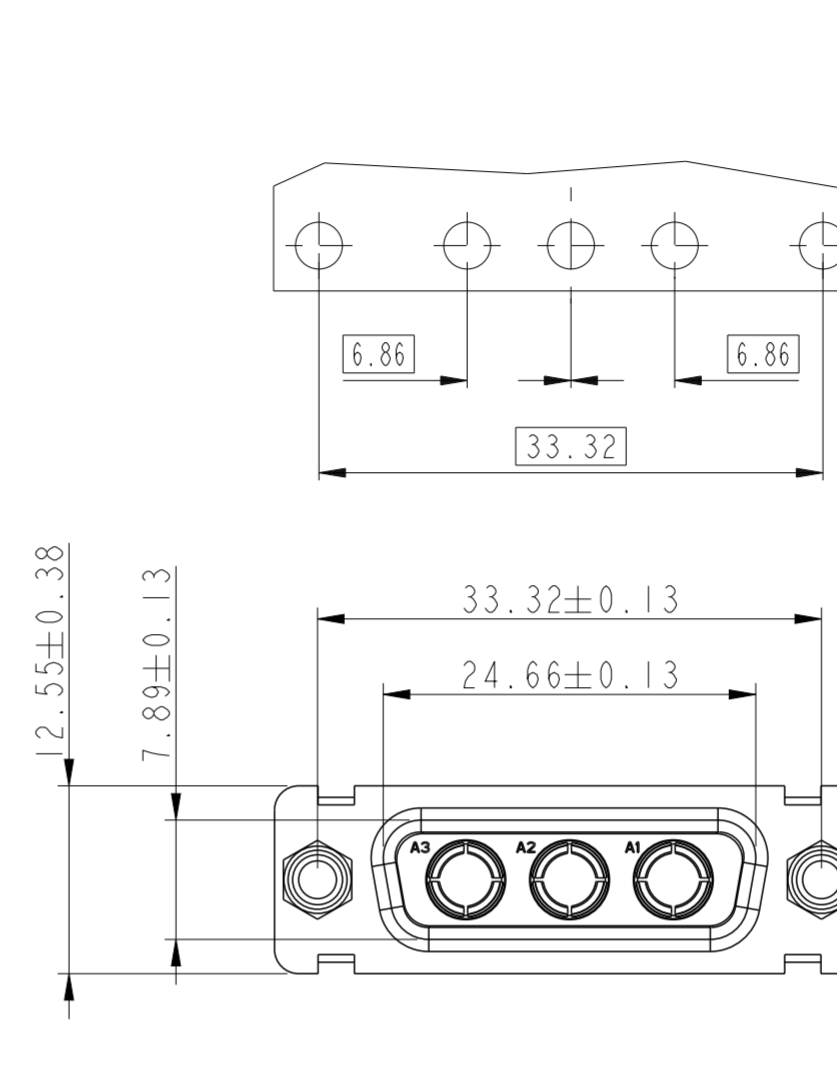

SIDE VIEW FOR LAYOUTS: E A B C

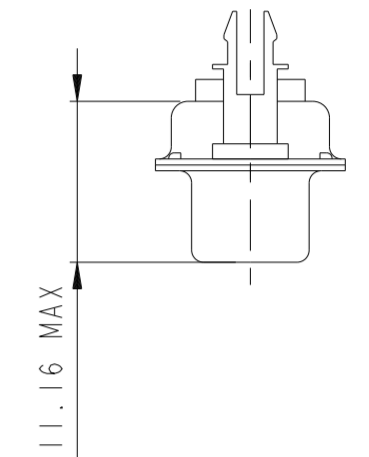

Cote "A"

30A	3.1±0.35
40A	3.6±0.35

spec ref	dr	1, Product Eng	2015/06/12	projection	MM	size	A2	scale	2:1
tolerance std	eng	Paul Mithun	2019/08/29			ecn no	ELX-33136-1	rel level	Released
ISO 406	chr	-							
ISO 1101	appr	Varma Sudhir	2019/09/03						
surface	linear	<b>Amphenol FCI</b>		product family	-	dwg no	C01-8639-2310	rev	G
ISO 1302	angular	0°	±2°	full power straight solder	-	ptc_wm		sheet 3 of 4	
TOLERANCES UNLESS OTHERWISE SPECIFIED				cat. no.	-	Product - Customer Drw			

# 5W5

## LAYOUT AND CONNECTOR DIMENSIONS

For PCB hole diameters see table I sheet 1

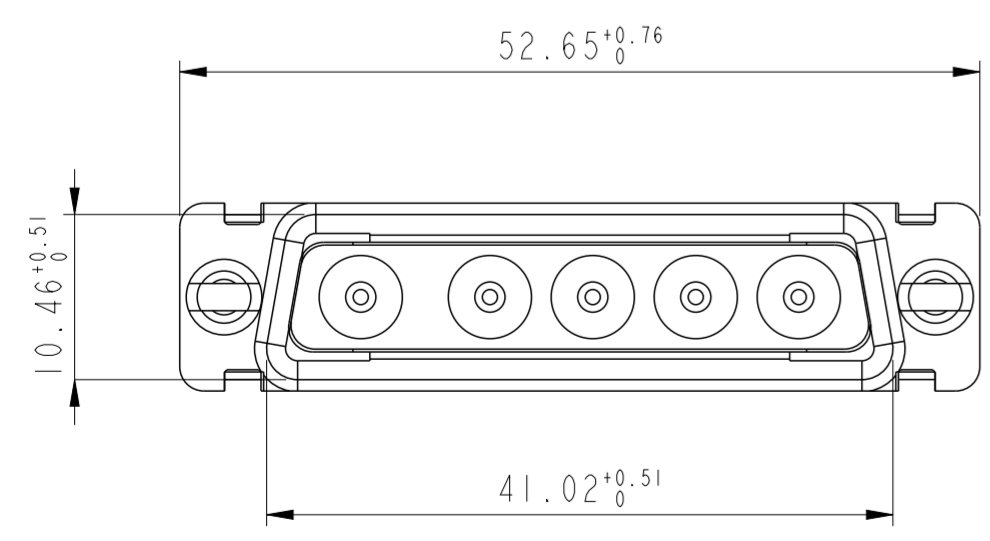
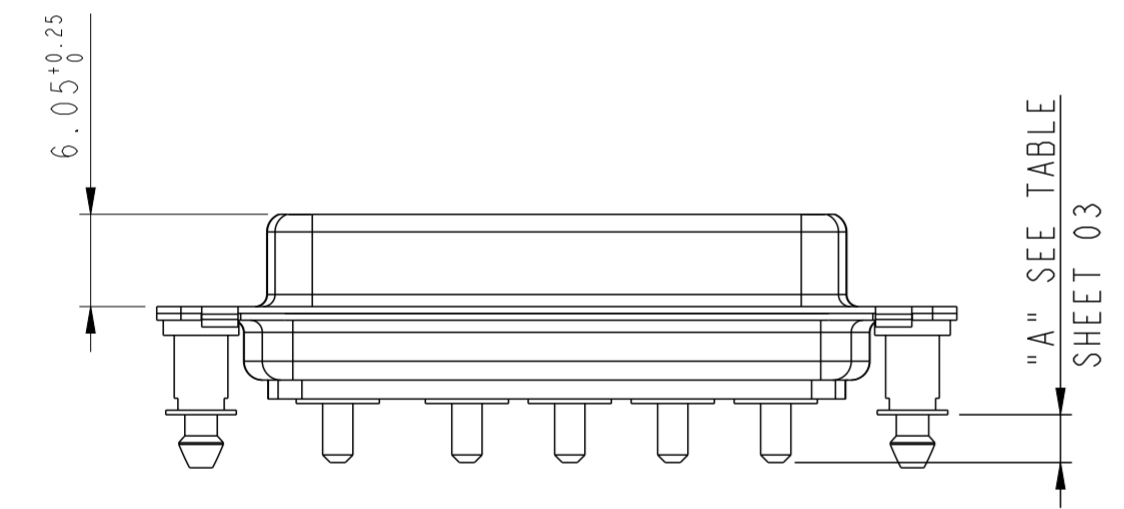
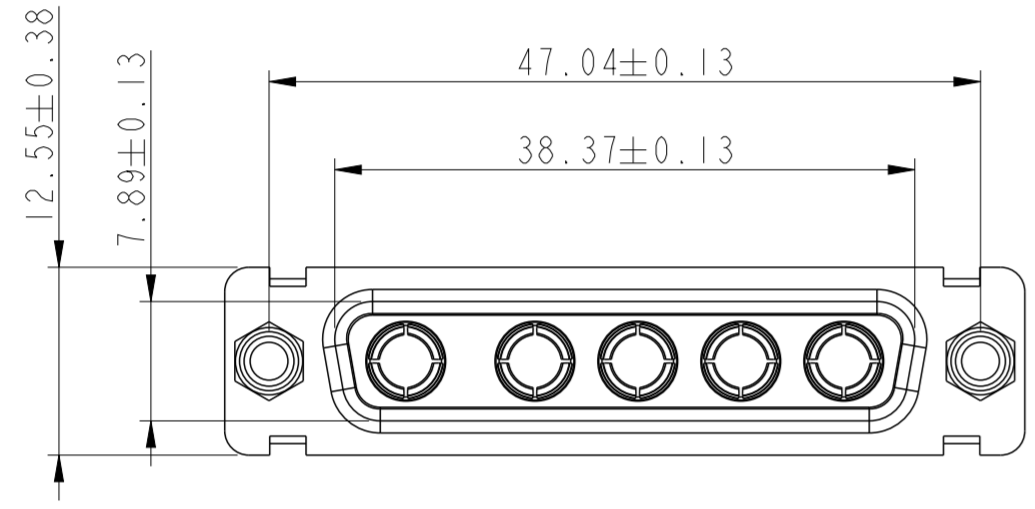
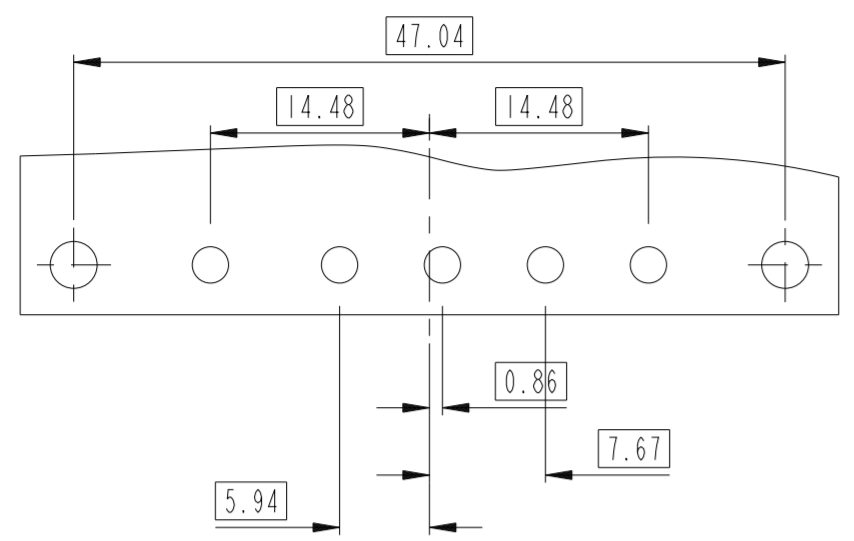

# 8W8

## LAYOUT AND CONNECTOR DIMENSIONS

For PCB hole diameters see table I sheet 1

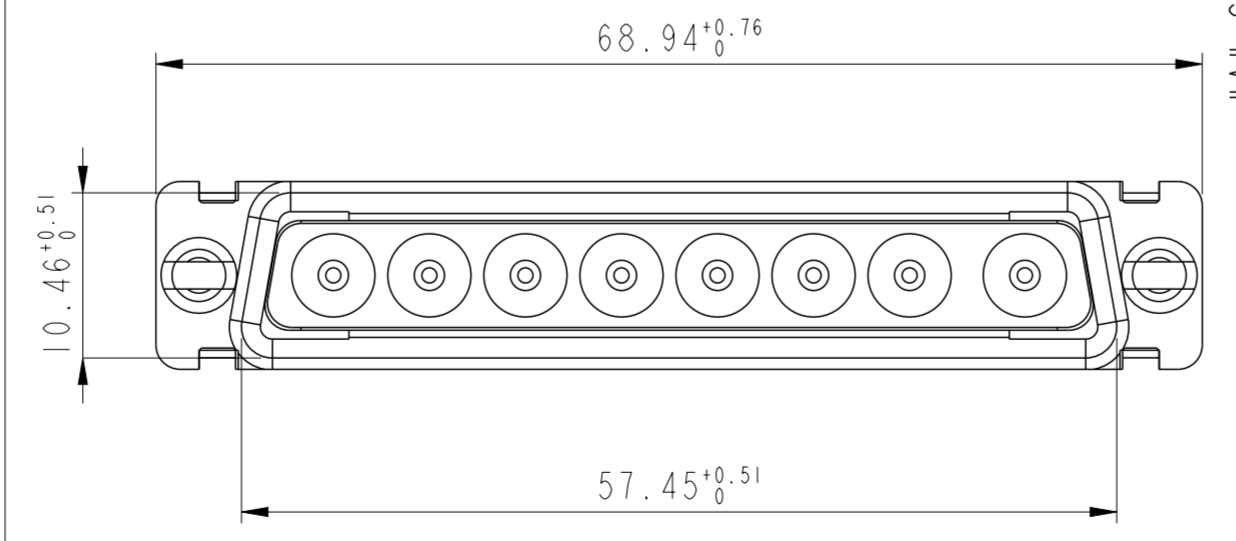
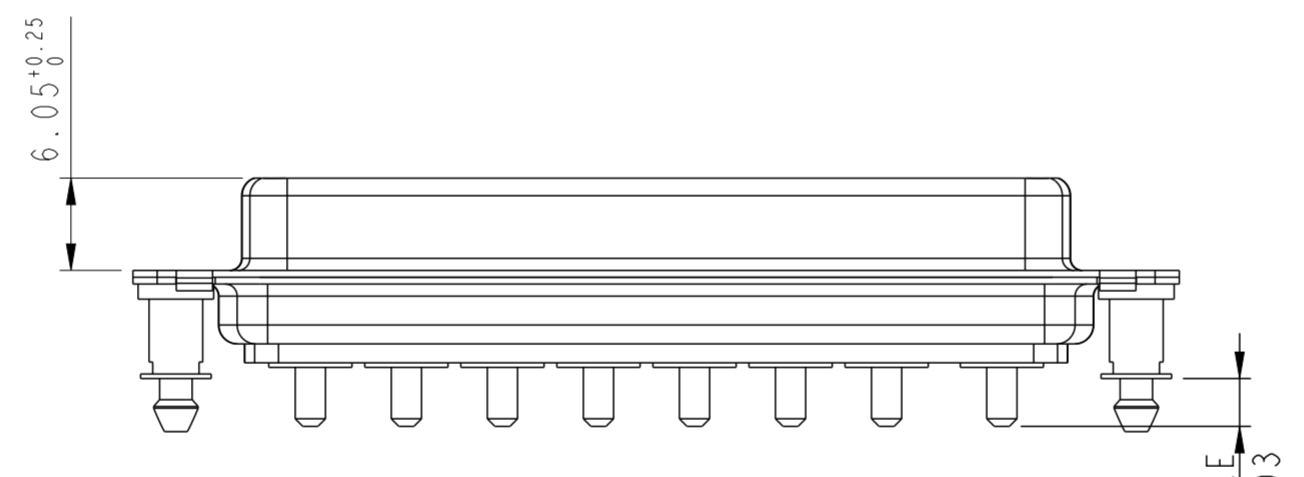
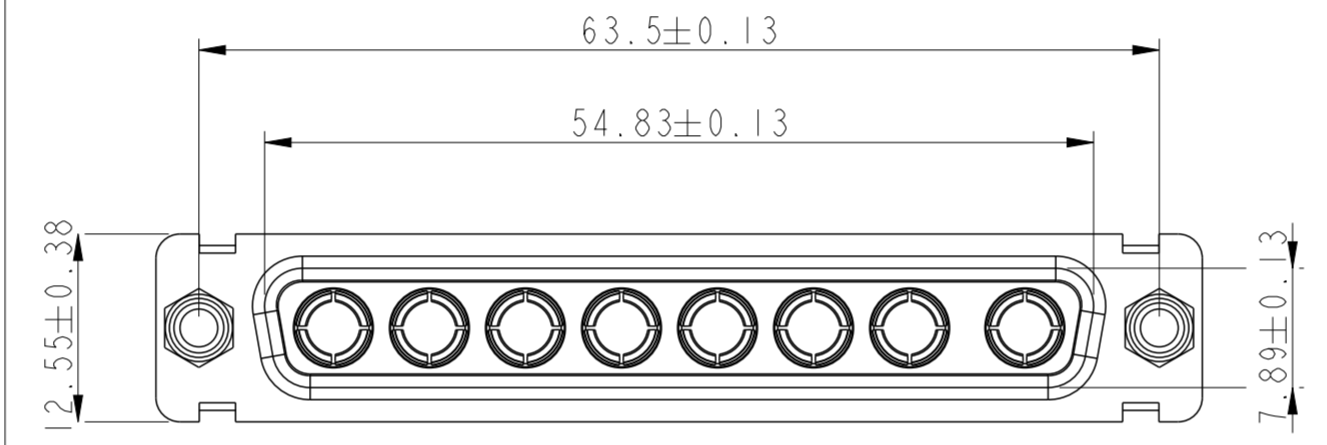
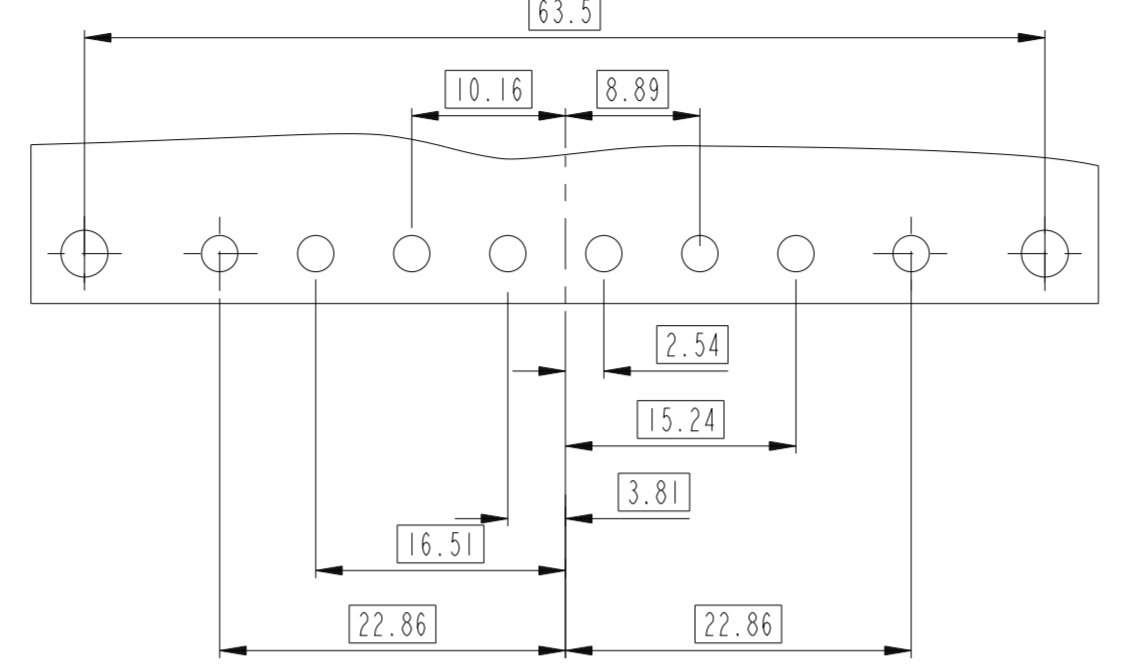

spec ref	dr	1, Product Eng	2015/06/12	projection	MM	size	A2	scale	2:1
tolerance std	eng	Paul Mithun	2019/08/29			ecn no	ELX-433136-1	rel level	Released
ISO 406	chr	-							
ISO 1101	appr	Varma Sudhir	2019/09/03						
TOLERANCES UNLESS OTHERWISE SPECIFIED		Amphenol FCI		SUB FEMALE DW		cat. no.		Product - Customer Drw	
surface	linear	0.X	±0.3	full power straight solder		dwg no	C01-8639-2310		rev
ISO 1302	angular	0.XX	±0.1	pfc_wm		sheet 4 of 4		G	
		0.XXX	±0.05						
		0°	±2°						