

| | | | |
|-------------|-------------------------------------|------|------|
| PART NUMBER | SMF-LX240IID-TR | REV. | C |
| DATE | E.C.N. NUMBER AND REVISION COMMENTS | | REV. |
| 07.12.13 | E.C.N. #11871. | | A |
| 10.03.13 | E.C.N. #11879. | | B |
| 06.05.14 | E.C.N. #11884. | | C |

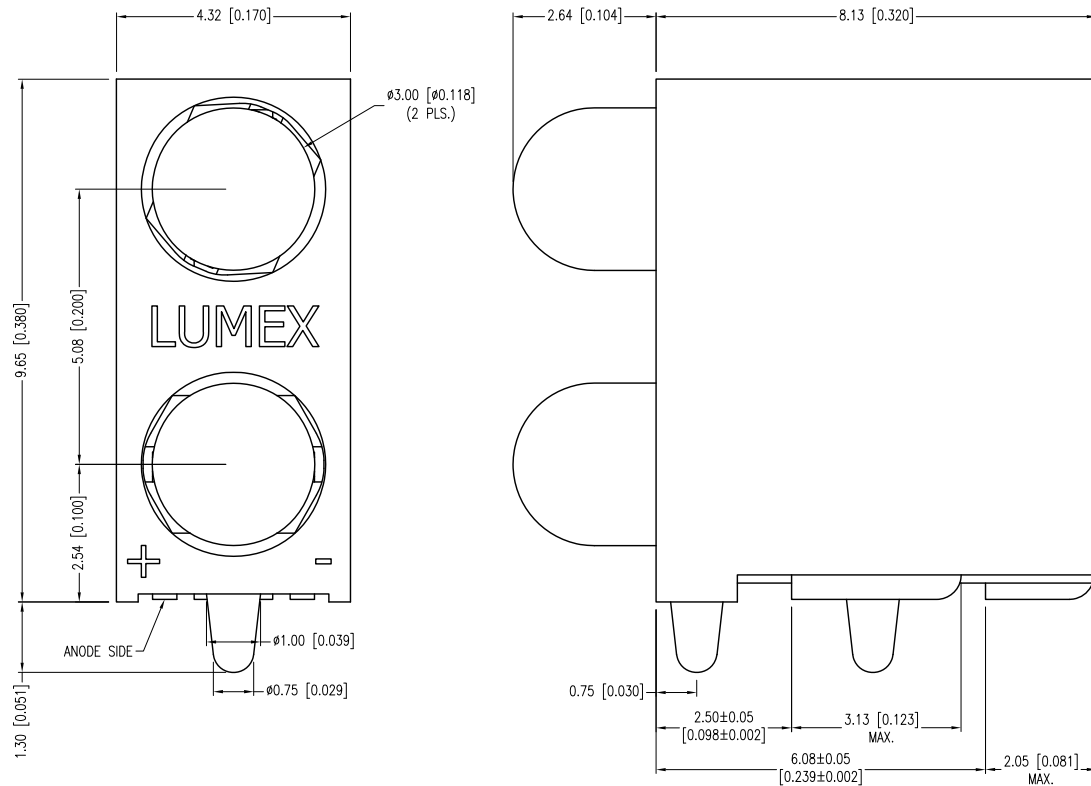

ELECTRO-OPTICAL CHARACTERISTICS $T_a=25^\circ\text{C}$ $I_f=20\text{mA}$

| PARAMETER | MIN | TYP | MAX | UNITS | TEST COND |
|-----------------|--------------|-----|-----|----------|----------------------|
| PEAK WAVELENGTH | | 635 | | nm | |
| FORWARD VOLTAGE | | 2.0 | 2.5 | Vf | |
| REVERSE VOLTAGE | 5.0 | | | Vr | $I_f=100\mu\text{A}$ |
| AXIAL INTENSITY | | 30 | | mcd | $I_f=20\text{mA}$ |
| VIEWING ANGLE | | 60 | | 2x theta | |
| EMITTED COLOR: | RED | | | | |
| LENS FINISH: | RED DIFFUSED | | | | |

LIMITS OF SAFE OPERATION AT 25°C

| PARAMETER | MAX | UNITS |
|-----------------------|------------|-------|
| PEAK FORWARD CURRENT* | 150 | mA |
| STEADY CURRENT | 30 | mA |
| POWER DISSIPATION | 105 | mW |
| DERATE FROM 25°C | -1.6 | mW/°C |
| OPERATING TEMP. | -40 TO +85 | °C |
| STORAGE TEMP. | -40 TO +85 | °C |

* $t < 10\mu\text{s}$

NOTES:

- SMH-LX240 HOLDER, BLACK.
- SSL-LX305F6YD, 2 PIECES.

[C] RECOMMENDED SOLDER PAD LAYOUT

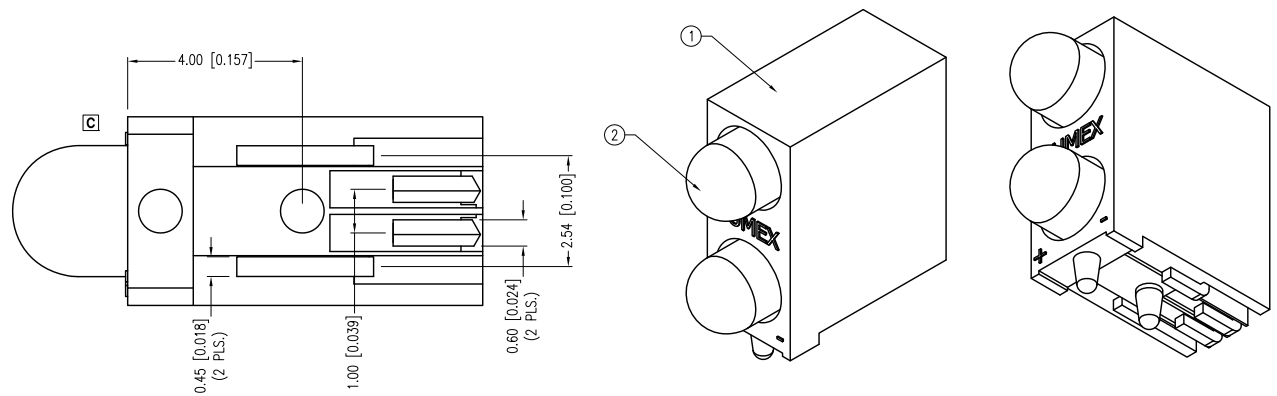
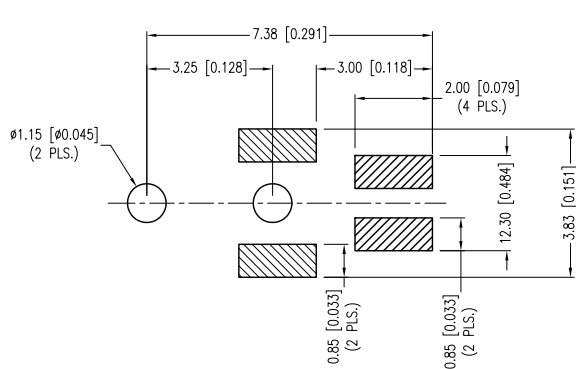

*UNLESS OTHERWISE SPECIFIED TOLERANCES PER DECIMAL PRECISION ARE: X=±1 (±0.039), X.X=±0.5 (±0.020), X.XX=±0.25 (±0.010), X.XXX=±0.127 (±0.005). LEAD SIZE=±0.05 (±0.002), LEAD LENGTH=±0.75 (±0.030). MIN.= +DECIMAL PRECISION MAX.= +DECIMAL PRECISION -0.00



425 N. GARY AVE.
CAROL STREAM, IL 60188-4900
PHONE: +1.800.278.5666
FAX: +1.630.315.2152
WEB: WWW.LUMEX.COM
MEMBER OF ITW PHOTONICS GROUP

QUASARBRITE 2 HIGH SMT RIGHT ANGLE LED INDICATOR, 635nm RED, RED DIFFUSED.

THE SPECIFICATIONS MAY CHANGE AT ANY TIME WITHOUT NOTICE DUE TO NEW MATERIALS OR PRODUCT IMPROVEMENT.

CONFIDENTIAL INFORMATION
THE INFORMATION CONTAINED IN THIS DOCUMENT IS THE PROPERTY OF LUMEX INC. EXCEPT AS SPECIFICALLY AUTHORIZED IN WRITING BY LUMEX INC., THE HOLDER OF THIS DOCUMENT SHALL KEEP ALL INFORMATION CONTAINED HEREIN CONFIDENTIAL AND SHALL PROTECT SAME IN WHOLE OR IN PART FROM DISCLOSURE AND DISSEMINATION TO ALL THIRD PARTIES.

| | | | |
|--------|-----------|-----------|------|
| DATE: | 07.27.12 | DRAWN BY: | AB |
| PAGE: | 1 OF 2 | CHKD BY: | SS |
| SCALE: | NTS | APRVD BY: | SS |
| UNIT: | mm [INCH] | | (Pb) |

| | | | |
|-------------|-------------------------------------|------|------|
| PART NUMBER | SMF-LX240IID-TR | REV. | C |
| DATE | E.C.N. NUMBER AND REVISION COMMENTS | | REV. |
| 07.12.13 | E.C.N. #11871. | | A |
| 10.03.13 | E.C.N. #11879. | | B |
| 06.05.14 | E.C.N. #11884. | | C |

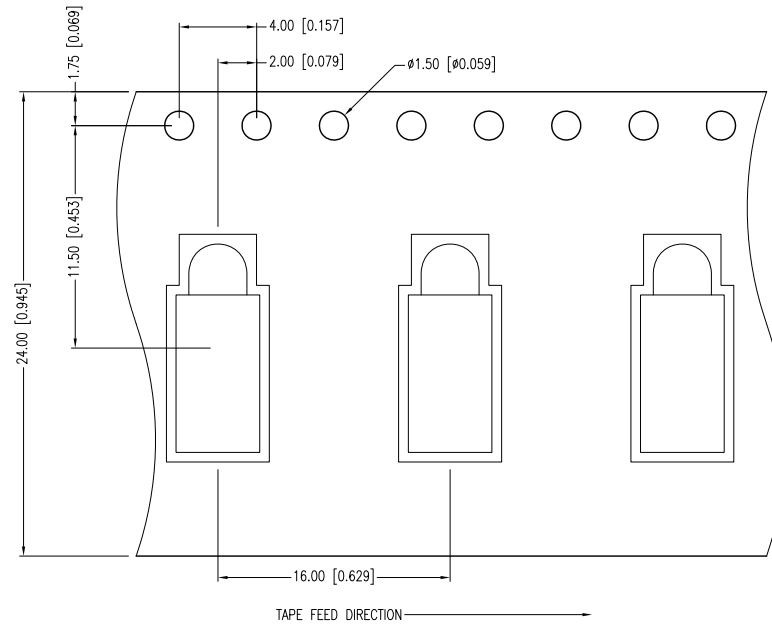
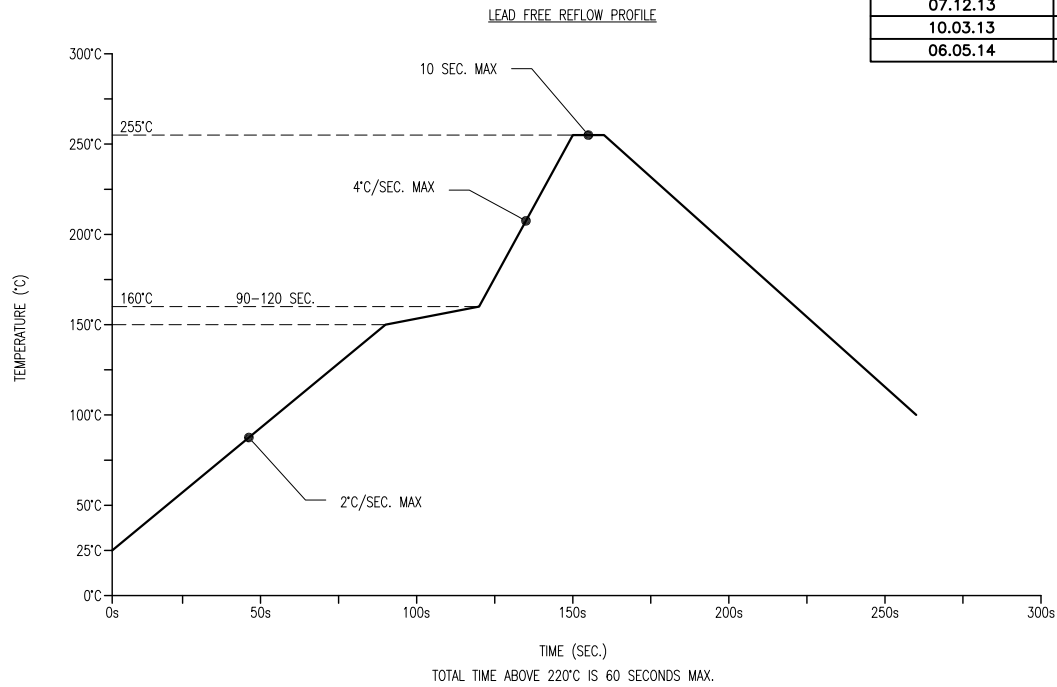

*UNLESS OTHERWISE SPECIFIED TOLERANCES PER DECIMAL PRECISION ARE: X=±1 (±0.039), X.X=±0.5 (±0.020), X.XX=±0.25 (±0.010), X.XXX=±0.127 (±0.005). LEAD SIZE=±0.05 (±0.002), LEAD LENGTH=±0.75 (±0.030). MIN= ^{+0.00}DECIMAL PRECISION MAX.= ^{-0.00}DECIMAL PRECISION



425 N. GARY AVE.
 CAROL STREAM, IL 60188-4900
 PHONE: +1.800.278.5666
 FAX: +1.630.315.2152
 WEB: WWW.LUMEX.COM
 MEMBER OF ITW PHOTONICS GROUP

QUASARBRITE 2 HIGH SMT RIGHT ANGLE LED INDICATOR, 635nm RED, RED DIFFUSED.

THE SPECIFICATIONS MAY CHANGE AT ANY TIME WITHOUT NOTICE DUE TO NEW MATERIALS OR PRODUCT IMPROVEMENT.

CONFIDENTIAL INFORMATION
 THE INFORMATION CONTAINED IN THIS DOCUMENT IS THE PROPERTY OF LUMEX INC. EXCEPT AS SPECIFICALLY AUTHORIZED IN WRITING BY LUMEX INC., THE HOLDER OF THIS DOCUMENT SHALL
 KEEP ALL INFORMATION CONTAINED HEREIN CONFIDENTIAL AND SHALL PROTECT SAME IN WHOLE OR IN PART FROM DISCLOSURE AND DISSEMINATION TO ALL THIRD PARTIES.

| | | | |
|--------|-----------|-----------|------|
| DATE: | 07.27.12 | DRAWN BY: | AB |
| PAGE: | 2 OF 2 | CHKD BY: | SS |
| SCALE: | NTS | APRVD BY: | SS |
| UNIT: | mm [INCH] | | (P6) |