

600mA CMOS LDO REGULATOR WITH ENABLE

AP2111

General Description

The AP2111 is CMOS process low dropout linear regulator with enable function, the regulator delivers a guaranteed 600mA (Min) continuous load current.

The AP2111 provides 1.2V, 1.5V, 1.8V, 2.5V, 3.3V, 4.8V regulated output and 0.8V to 5V adjustable output, and provides excellent output accuracy 1.5%, it is also provides a excellent load regulation, line regulation and excellent load transient performance due to very fast loop response. The AP2111 has built-in auto discharge function.

The AP2111 features low power consumption.

The AP2111 is available in SOIC-8, PSOP-8 SOT-223 and SOT-23-5 packages.

Features

- Output Voltage Accuracy: $\pm 1.5\%$
- Output Current: 600mA (Min)
- Foldback Short Current Protection: 50mA
- Enable Function to Turn On/Off V_{OUT}
- Low Dropout Voltage (3.3V): 250mV (Typ) @ $I_{OUT}=600mA$
- Excellent Load Regulation: 0.2%/A (Typ)
- Excellent Line Regulation: 0.02%/V (Typ)
- Low Quiescent Current: 55 μA (Typ)
- Low Standby Current: 0.01 μA (Typ)
- Low Output Noise: 50 μV_{RMS}
- PSRR: 65dB @ $f=1kHz$, 65dB @ $f=100Hz$
- OTSD Protection
- Stable with 1.0 μF Flexible Cap: Ceramic, Tantalum and Aluminum Electrolytic
- Operating Temperature Range: -40°C to 85°C
- ESD: MM 400V, HBM 4000V

Applications

- Laptop computer
- Potable DVD
- LCD Monitor

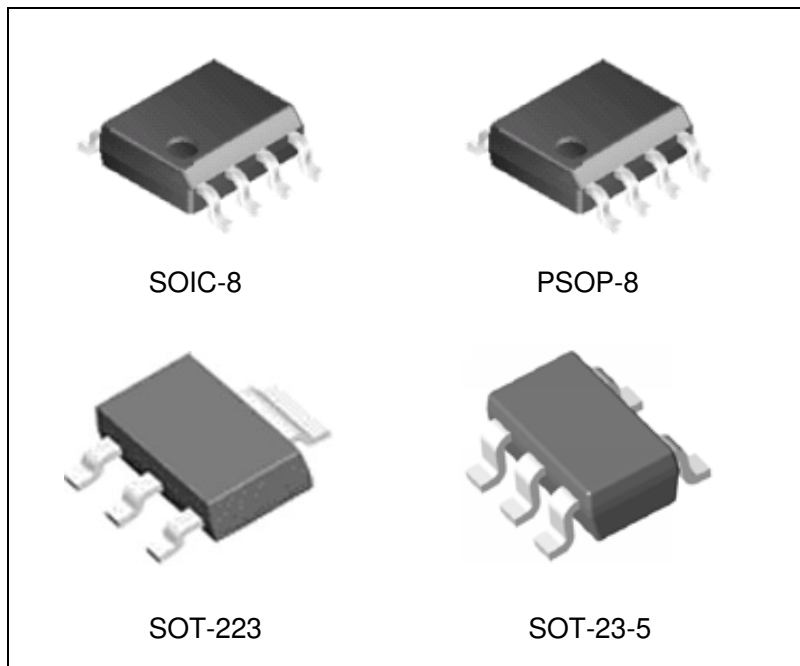

Figure 1. Package Types of AP2111

600mA CMOS LDO REGULATOR WITH ENABLE
AP2111
Pin Configuration

Figure 2. Pin Configuration of AP2111 (Top View)

Pin Descriptions

Pin Number				Pin Name	Function
SOIC-8/PSOP-8	SOT-223(H)	SOT-223(HA)	SOT-23-5		
4	3	2	3	VIN	Input voltage
2	2	3	4	VOUT	Output voltage
8			1	EN	Chip enable, H – normal work, L – shutdown output
1, 3, 5, 6, 7	1	1	2	GND	Ground
			5	ADJ/NC	Adjust output for ADJ version/No connected for fixed version

600mA CMOS LDO REGULATOR WITH ENABLE

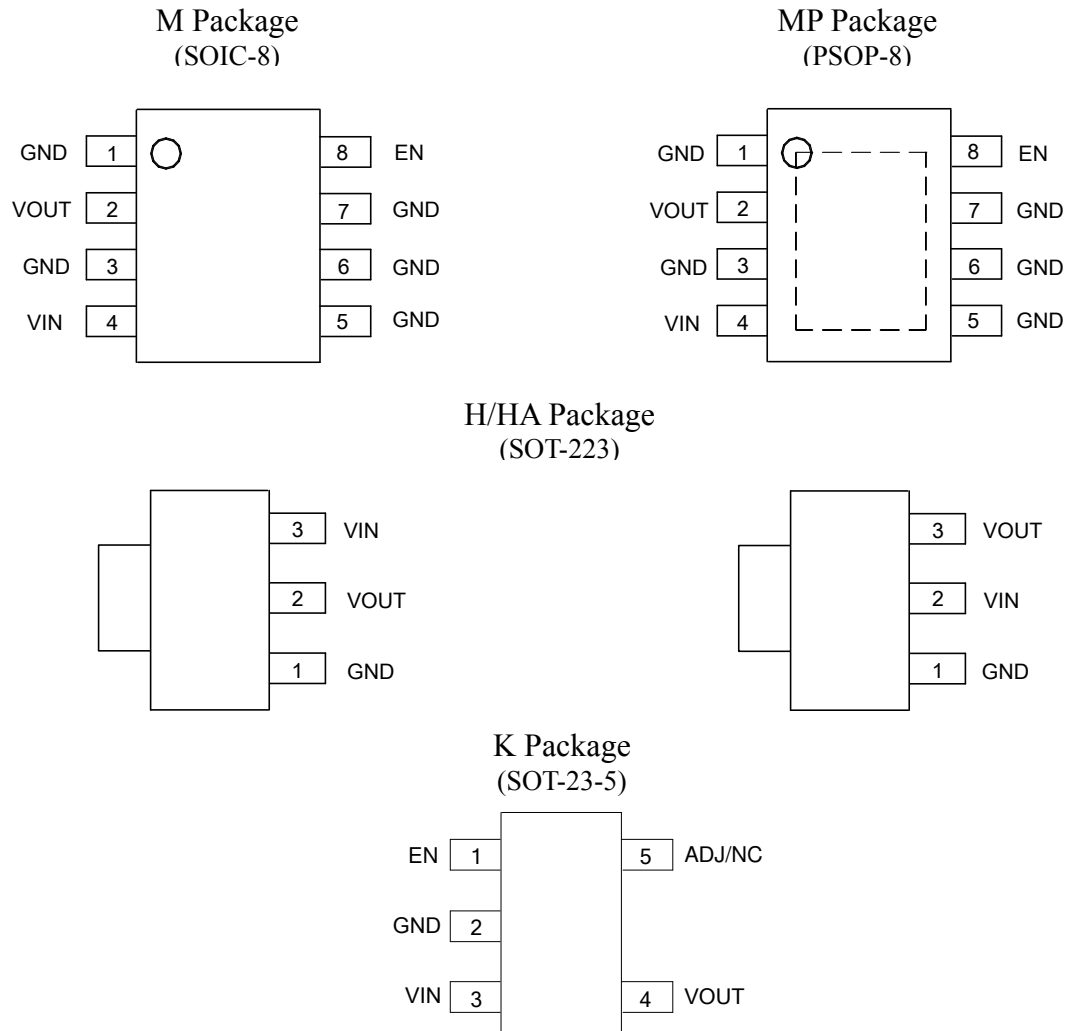
AP2111

Functional Block Diagram

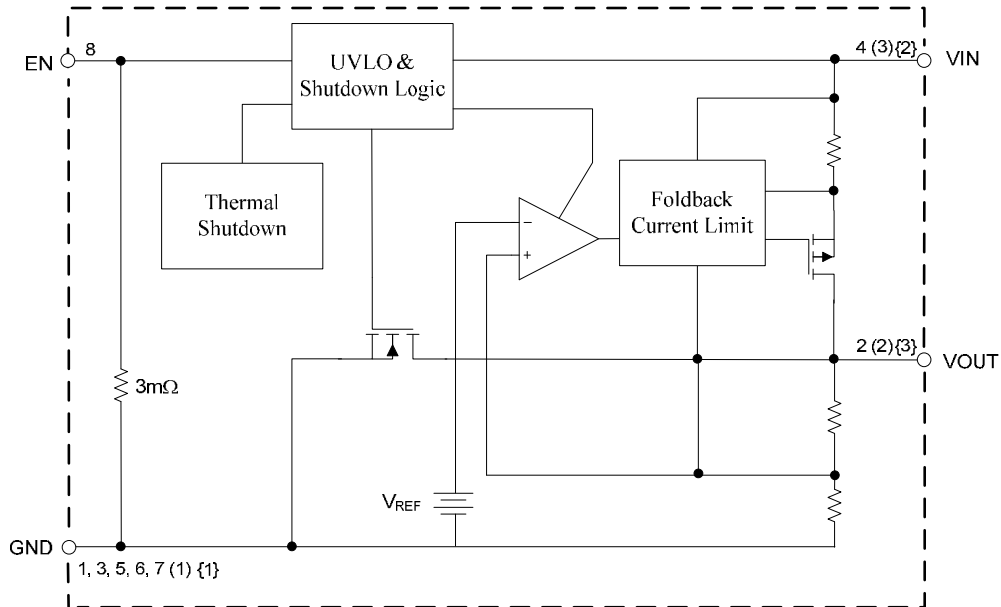

A (B) {C}
 A: SOIC-8/PSOP-8
 B: SOT-223(H)
 C: SOT-223(HA)

Figure 3. Functional Block Diagram of AP2111 for Fixed Version

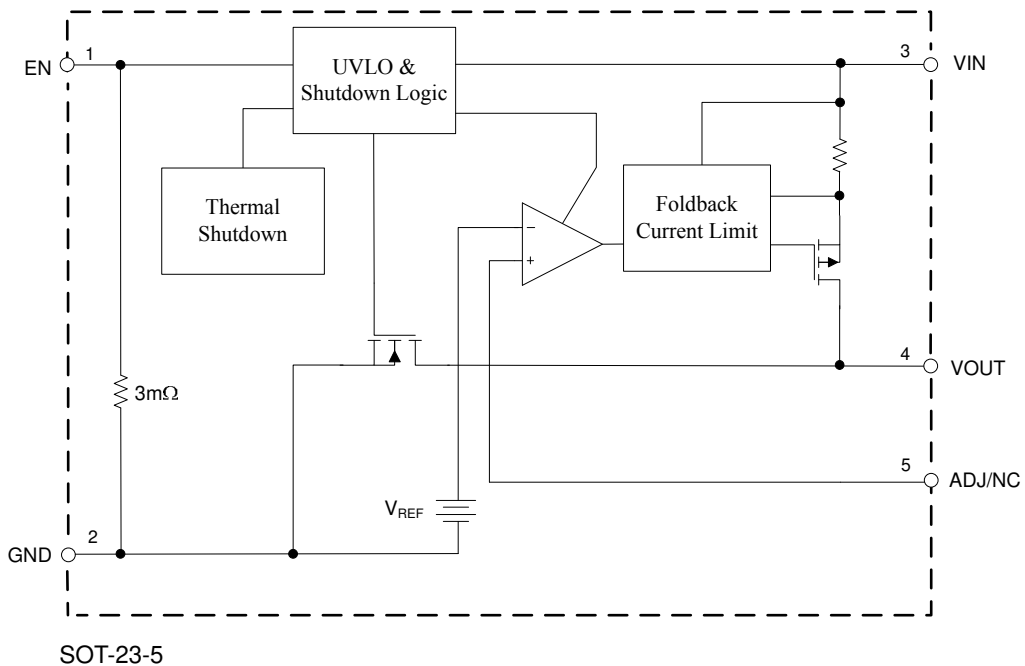

SOT-23-5

Figure 4. Functional Block Diagram of AP2111 for Adjustable Version

600mA CMOS LDO REGULATOR WITH ENABLE

AP2111

Ordering Information

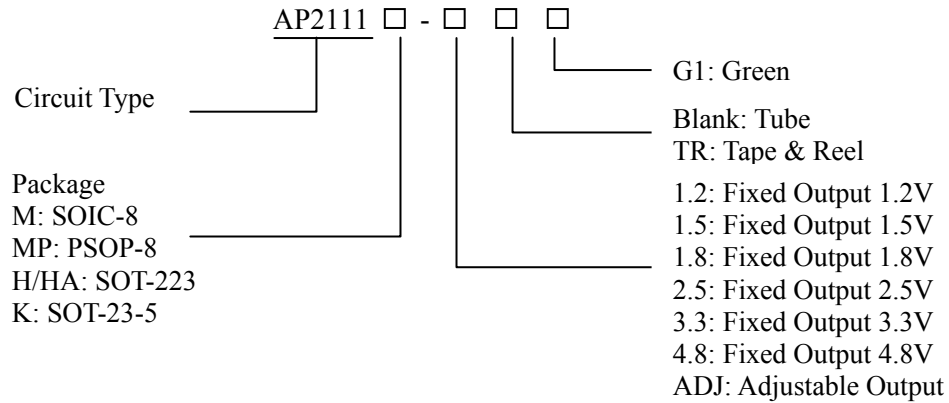

Package	Temperature Range	Part Number	Marking ID	Packing Type
SOIC-8	-40 to 85°C	AP2111M-1.2G1	2111M-1.2G1	Tube
		AP2111M-1.2TRG1	2111M-1.2G1	Tape & Reel
		AP2111M-1.5G1	2111M-1.5G1	Tube
		AP2111M-1.5TRG1	2111M-1.5G1	Tape & Reel
		AP2111M-1.8G1	2111M-1.8G1	Tube
		AP2111M-1.8TRG1	2111M-1.8G1	Tape & Reel
		AP2111M-2.5G1	2111M-2.5G1	Tube
		AP2111M-2.5TRG1	2111M-2.5G1	Tape & Reel
		AP2111M-3.3G1	2111M-3.3G1	Tube
		AP2111M-3.3TRG1	2111M-3.3G1	Tape & Reel
PSOP-8	-40 to 85°C	AP2111MP-1.2G1	2111MP-1.2G1	Tube
		AP2111MP-1.2TRG1	2111MP-1.2G1	Tape & Reel
		AP2111MP-1.5G1	2111MP-1.5G1	Tube
		AP2111MP-1.5TRG1	2111MP-1.5G1	Tape & Reel
		AP2111MP-1.8G1	2111MP-1.8G1	Tube
		AP2111MP-1.8TRG1	2111MP-1.8G1	Tape & Reel
		AP2111MP-2.5G1	2111MP-2.5G1	Tube
		AP2111MP-2.5TRG1	2111MP-2.5G1	Tape & Reel
		AP2111MP-3.3G1	2111MP-3.3G1	Tube
		AP2111MP-3.3TRG1	2111MP-3.3G1	Tape & Reel
SOT-223(H)	-40 to 85°C	AP2111H-1.2TRG1	GH11B	Tape & Reel
		AP2111H-1.5TRG1	GH13G	Tape & Reel
		AP2111H-1.8TRG1	GH11G	Tape & Reel
		AP2111H-2.5TRG1	GH11H	Tape & Reel
		AP2111H-3.3TRG1	GH11C	Tape & Reel
		AP2111H-4.8TRG1	GH13D	Tape & Reel

**600mA CMOS LDO REGULATOR WITH ENABLE****AP2111****Ordering Information (Continued)**

Package	Temperature Range	Part Number	Marking ID	Packing Type
SOT-223(HA)	-40 to 85°C	AP2111HA-1.2TRG1	GH11J	Tape & Reel
		AP2111HA-1.5TRG1	GH14G	Tape & Reel
		AP2111HA-1.8TRG1	GH11K	Tape & Reel
		AP2111HA-2.5TRG1	GH11L	Tape & Reel
		AP2111HA-3.3TRG1	GH11M	Tape & Reel
		AP2111HA-4.8TRG1	GH11N	Tape & Reel
SOT-23-5	-40 to 85°C	AP2111K-1.5TRG1	G3S	Tape & Reel
		AP2111K-ADJG1	G3Q	Tube
		AP2111K-ADJTRG1	G3Q	Tape & Reel

BCD Semiconductor's Pb-free products, as designated with "G1" suffix in the part number, are RoHS compliant and Green.

**600mA CMOS LDO REGULATOR WITH ENABLE****AP2111****Absolute Maximum Ratings (Note 1)**

Parameter	Symbol	Value		Unit
Power Supply Voltage	V_{IN}	6.5		V
Operating Junction Temperature Range	T_J	150		°C
Storage Temperature Range	T_{STG}	-65 to 150		°C
Lead Temperature (Soldering, 10sec)	T_{LEAD}	260		°C
Thermal Resistance (No Heatsink)	θ_{JA}	SOIC-8	144	°C/W
		PSOP-8	143	
		SOT-223	128	
		SOT-23-5	250	
ESD (Machine Model)		400		V
ESD (Human Body Model)		4000		V

Note 1: Stresses greater than those listed under “Absolute Maximum Ratings” may cause permanent damage to the device. These are stress ratings only, and functional operation of the device at these or any other conditions beyond those indicated under “Recommended Operating Conditions” is not implied. Exposure to “Absolute Maximum Ratings” for extended periods may affect device reliability.

Recommended Operating Conditions

Parameter	Symbol	Min	Typ	Max	Unit
Supply Voltage	V_{IN}	2.5		6.0	V
Operating Ambient Temperature Range	T_A	-40		85	°C



600mA CMOS LDO REGULATOR WITH ENABLE

AP2111

Electrical Characteristics

AP2111-1.2 Electrical Characteristic (Note 2)

V_{IN}=2.5V, C_{IN}=1.0μF (Ceramic), C_{OUT}=1.0μF (Ceramic), Typical T_A=25°C, **Bold** typeface applies over -40°C≤T_A≤85°C ranges, unless otherwise specified (Note 3).

Parameter	Symbol	Conditions	Min	Typ	Max	Unit
Output Voltage	V _{OUT}	V _{IN} =2.5V, 1mA ≤ I _{OUT} ≤ 30mA	$\frac{V_{OUT}}{\times 98.5\%}$	1.2	$\frac{V_{OUT}}{\times 101.5\%}$	V
Maximum Output Current	I _{OUT(Max)}	V _{IN} =2.5V, V _{OUT} =1.182V to 1.218V	600			mA
Load Regulation	$\frac{(\Delta V_{OUT}/V_{OUT})}{\Delta I_{OUT}}$	V _{IN} =2.5V, 1mA ≤ I _{OUT} ≤ 600mA		0.2		%/A
Line Regulation	$\frac{(\Delta V_{OUT}/V_{OUT})}{\Delta V_{IN}}$	2.5V ≤ V _{IN} ≤ 6V, I _{OUT} =30mA		0.02		%/V
Dropout Voltage	V _{DROP}	I _{OUT} =10mA		1000	1300	mV
		I _{OUT} =300mA		1000	1300	
		I _{OUT} =600mA		1000	1300	
Quiescent Current	I _Q	V _{IN} =2.5V, I _{OUT} =0mA		55	80	μA
Standby Current	I _{STD}	V _{IN} =2.5V, V _{EN} in OFF mode		0.01	1.0	μA
Power Supply Rejection Ratio	PSRR	Ripple 0.5Vp-p V _{IN} =2.5V, I _{OUT} =100mA	f=100Hz	65		dB
			f=1kHz	65		
Output Voltage Temperature Coefficient	$\frac{(\Delta V_{OUT}/V_{OUT})}{\Delta T}$	I _{OUT} =30mA T _A =-40°C to 85°C		±100		ppm/°C
Short Current Limit	I _{SHORT}	V _{OUT} =0V		50		mA
RMS Output Noise	V _{NOISE}	No Load, 10Hz ≤ f ≤ 100kHz		50		μV _{RMS}
VEN High Voltage	V _{IH}	Enable logic high, regulator on	1.5		6.0	V
VEN Low Voltage	V _{IL}	Enable logic low, regulator off	0		0.4	
Start-up Time	t _S	No Load		20		μs
EN Pull Down Resistor	R _{PD}			3.0		mΩ
V _{OUT} Discharge Resistor	R _{DCHG}	Set EN pin at Low		60		Ω
Thermal Shutdown Temperature	T _{OTSD}			160		°C
Thermal Shutdown Hysteresis	T _{HYOTSD}			30		
Thermal Resistance (Junction to Case)	θ _{JC}	SOIC-8		74.6		°C/W
		PSOP-8		43.7		
		SOT-223		50.9		

Note 2: To prevent the Short Circuit Current protection feature from being prematurely activated, the input voltage must be applied before a current source load is applied.

Note 3: Production testing at T_A=25°C. Over temperature specifications guaranteed by design only.



600mA CMOS LDO REGULATOR WITH ENABLE

AP2111

Electrical Characteristics (Continued)

AP2111-1.5 Electrical Characteristic (Note 2)

V_{IN}=2.5V, C_{IN}=1.0μF (Ceramic), C_{OUT}=1.0μF (Ceramic), Typical T_A=25°C, **Bold** typeface applies over -40°C≤T_A≤85°C ranges, unless otherwise specified (Note 3).

Parameter	Symbol	Conditions	Min	Typ	Max	Unit
Output Voltage	V _{OUT}	V _{IN} =2.5V, 1mA ≤ I _{OUT} ≤ 30mA	$\frac{V_{OUT}}{\times 98.5\%}$	1.5	$\frac{V_{OUT}}{\times 101.5\%}$	V
Maximum Output Current	I _{OUT(Max)}	V _{IN} =2.5V, V _{OUT} =1.478V to 1.523V	600			mA
Load Regulation	$\frac{(\Delta V_{OUT}/V_{OUT})}{\Delta I_{OUT}}$	V _{IN} =2.5V, 1mA ≤ I _{OUT} ≤ 600mA		0.2		%/A
Line Regulation	$\frac{(\Delta V_{OUT}/V_{OUT})}{\Delta V_{IN}}$	2.5V ≤ V _{IN} ≤ 6V, I _{OUT} =30mA		0.02		%/V
Dropout Voltage	V _{DROP}	I _{OUT} =10mA		700	1000	mV
		I _{OUT} =300mA		700	1000	
		I _{OUT} =600mA		700	1000	
Quiescent Current	I _Q	V _{IN} =2.5V, I _{OUT} =0mA		55	80	μA
Standby Current	I _{STD}	V _{IN} =2.5V, V _{EN} in OFF mode		0.01	1.0	μA
Power Supply Rejection Ratio	PSRR	Ripple 0.5Vp-p V _{IN} =2.5V, I _{OUT} =100mA	f=100Hz	65		dB
			f=1kHz	65		
Output Voltage Temperature Coefficient	$\frac{(\Delta V_{OUT}/V_{OUT})}{\Delta T}$	I _{OUT} =30mA T _A =-40°C to 85°C		±100		ppm/°C
Short Current Limit	I _{SHORT}	V _{OUT} =0V		50		mA
RMS Output Noise	V _{NOISE}	No Load, 10Hz ≤ f ≤ 100kHz		50		μV _{RMS}
VEN High Voltage	V _{IH}	Enable logic high, regulator on	1.5		6.0	V
VEN Low Voltage	V _{IL}	Enable logic low, regulator off	0		0.4	
Start-up Time	t _S	No Load		20		μs
EN Pull Down Resistor	R _{PD}			3.0		mΩ
V _{OUT} Discharge Resistor	R _{DCHG}	Set EN pin at Low		60		Ω
Thermal Shutdown Temperature	T _{OTSD}			160		°C
Thermal Shutdown Hysteresis	T _{HYOTSD}			30		
Thermal Resistance (Junction to Case)	θ _{JC}	SOIC-8		74.6		°C/W
		PSOP-8		43.7		
		SOT-223		50.9		
		SOT-23-5		150		

Note 2: To prevent the Short Circuit Current protection feature from being prematurely activated, the input voltage must be applied before a current source load is applied.

Note 3: Production testing at T_A=25°C. Over temperature specifications guaranteed by design only.



600mA CMOS LDO REGULATOR WITH ENABLE

AP2111

Electrical Characteristics (Continued)

AP2111-1.8 Electrical Characteristic (Note 2)

V_{IN}=2.8V, C_{IN}=1μF (Ceramic), C_{OUT}=1μF (Ceramic), Typical T_A=25°C, **Bold** typeface applies over -40°C≤T_A≤85°C ranges, unless otherwise specified (Note 3).

Parameter	Symbol	Conditions	Min	Typ	Max	Unit
Output Voltage	V _{OUT}	V _{IN} =2.8V, 1mA ≤ I _{OUT} ≤ 30mA	$\frac{V_{OUT}}{\times 98.5\%}$	1.8	$\frac{V_{OUT}}{\times 101.5\%}$	V
Maximum Output Current	I _{OUT(Max)}	V _{IN} =2.8V, V _{OUT} =1.773V to 1.827V	600			mA
Load Regulation	$\frac{\Delta V_{OUT}/V_{OUT}}{\Delta I_{OUT}}$	V _{OUT} =1.8V, V _{IN} =V _{OUT} +1V, 1mA ≤ I _{OUT} ≤ 600mA		0.2		%/A
Line Regulation	$\frac{\Delta V_{OUT}/V_{OUT}}{\Delta V_{IN}}$	2.8V ≤ V _{IN} ≤ 6V, I _{OUT} =30mA		0.02		%/V
Dropout Voltage	V _{DROP}	I _{OUT} =10mA		500	700	mV
		I _{OUT} =300mA		500	700	
		I _{OUT} =600mA		500	700	
Quiescent Current	I _Q	V _{IN} =2.8V, I _{OUT} =0mA		55	80	μA
Standby Current	I _{STD}	V _{IN} =2.8V, V _{EN} in OFF mode		0.01	1.0	μA
Power Supply Rejection Ratio	PSRR	Ripple 0.5Vp-p V _{IN} =2.8V, I _{OUT} =100mA	f=100Hz		65	dB
			f=1kHz		65	
Output Voltage Temperature Coefficient	$\frac{\Delta V_{OUT}/V_{OUT}}{\Delta T}$	I _{OUT} =30mA T _A =-40°C to 85°C		±100		ppm/°C
Short Current Limit	I _{SHORT}	V _{OUT} =0V		50		mA
RMS Output Noise	V _{NOISE}	No Load, 10Hz ≤ f ≤ 100kHz		50		μV _{RMS}
VEN High Voltage	V _{IH}	Enable logic high, regulator on	1.5		6.0	V
VEN Low Voltage	V _{IL}	Enable logic low, regulator off	0		0.4	
Start-up Time	t _S	No Load		20		μs
EN Pull Down Resistor	R _{PD}			3.0		mΩ
VOU _T Discharge Resistor	R _{DCHG}	Set EN pin at Low		60		Ω
Thermal Shutdown Temperature	T _{OTS_D}			160		°C
Thermal Shutdown Hysteresis	T _{HYOTS_D}			30		
Thermal Resistance (Junction to Case)	θ _{JC}	SOIC-8		74.6		°C/W
		PSOP-8		43.7		
		SOT-223		50.9		

Note 2: To prevent the Short Circuit Current protection feature from being prematurely activated, the input voltage must be applied before a current source load is applied.

Note 3: Production testing at T_A=25°C. Over temperature specifications guaranteed by design only.



600mA CMOS LDO REGULATOR WITH ENABLE

AP2111

Electrical Characteristics (Continued)

AP2111-2.5 Electrical Characteristic (Note 2)

V_{IN}=3.5V, C_{IN}=1μF (Ceramic), C_{OUT}=1μF (Ceramic), Typical T_A=25°C, **Bold** typeface applies over -40°C≤T_A≤85°C ranges, unless otherwise specified (Note 3).

Parameter	Symbol	Conditions	Min	Typ	Max	Unit
Output Voltage	V _{OUT}	V _{IN} =3.5V, 1mA ≤ I _{OUT} ≤ 30mA	$\frac{V_{OUT}}{\times 98.5\%}$	2.5	$\frac{V_{OUT}}{\times 101.5\%}$	V
Maximum Output Current	I _{OUT(Max)}	V _{IN} =3.5V, V _{OUT} =2.463V to 2.537V	600			mA
Load Regulation	$\frac{(\Delta V_{OUT}/V_{OUT})}{\Delta I_{OUT}}$	V _{OUT} =2.5V, V _{IN} =V _{OUT} +1V, 1mA ≤ I _{OUT} ≤ 600mA		0.2		%/A
Line Regulation	$\frac{(\Delta V_{OUT}/V_{OUT})}{\Delta V_{IN}}$	3.5V ≤ V _{IN} ≤ 6V, I _{OUT} =30mA		0.02		%/V
Dropout Voltage	V _{DROP}	I _{OUT} =10mA		5	8	mV
		I _{OUT} =300mA		125	200	
		I _{OUT} =600mA		250	400	
Quiescent Current	I _Q	V _{IN} =3.5V, I _{OUT} =0mA		55	80	μA
Standby Current	I _{STD}	V _{IN} =3.5V, V _{EN} in OFF mode		0.01	1.0	μA
Power Supply Rejection Ratio	PSRR	Ripple 0.5Vp-p V _{IN} =3.5V, I _{OUT} =100mA	f=100Hz	65		dB
			f=1kHz	65		
Output Voltage Temperature Coefficient	$\frac{(\Delta V_{OUT}/V_{OUT})}{\Delta T}$	I _{OUT} =30mA T _A =-40°C to 85°C		±100		ppm/°C
Short Current Limit	I _{SHORT}	V _{OUT} =0V		50		mA
RMS Output Noise	V _{NOISE}	No Load, 10Hz ≤ f ≤ 100kHz		50		μV _{RMS}
VEN High Voltage	V _{IH}	Enable logic high, regulator on	1.5		6.0	V
VEN Low Voltage	V _{IL}	Enable logic low, regulator off	0		0.4	
Start-up Time	t _S	No Load		20		μs
EN Pull Down Resistor	R _{PD}			3.0		mΩ
VOOUT Discharge Resistor	R _{DCHG}	Set EN pin at Low		60		Ω
Thermal Shutdown Temperature	T _{OTSD}			160		°C
Thermal Shutdown Hysteresis	T _{HYOTSD}			30		
Thermal Resistance (Junction to Case)	θ _{JC}	SOIC-8		74.6		°C/W
		PSOP-8		43.7		
		SOT-223		50.9		

Note 2: To prevent the short circuit current protection feature from being prematurely activated, the input voltage must be applied before a current source load is applied.

Note 3: Production testing at T_A=25°C. Over temperature specifications guaranteed by design only.



600mA CMOS LDO REGULATOR WITH ENABLE

AP2111

Electrical Characteristics (Continued)

AP2111-3.3 Electrical Characteristic (Note 2)

V_{IN}=4.3V, C_{IN}=1μF (Ceramic), C_{OUT}=1μF (Ceramic), Typical T_A=25°C, **Bold** typeface applies over -40°C≤T_A≤85°C ranges, unless otherwise specified (Note 3).

Parameter	Symbol	Conditions	Min	Typ	Max	Unit
Output Voltage	V _{OUT}	V _{IN} =4.3V, 1mA ≤ I _{OUT} ≤ 30mA	$\frac{V_{OUT}}{\times 98.5\%}$	3.3	$\frac{V_{OUT}}{\times 101.5\%}$	V
Maximum Output Current	I _{OUT(Max)}	V _{IN} =4.3V, V _{OUT} =3.251V to 3.350V	600			mA
Load Regulation	$\frac{(\Delta V_{OUT}/V_{OUT})}{\Delta I_{OUT}}$	V _{IN} =4.3V, 1mA ≤ I _{OUT} ≤ 600mA		0.2		%/A
Line Regulation	$\frac{(\Delta V_{OUT}/V_{OUT})}{\Delta V_{IN}}$	4.3V ≤ V _{IN} ≤ 6V, I _{OUT} =30mA		0.02		%/V
Dropout Voltage	V _{DROP}	I _{OUT} =10mA		5	8	mV
		I _{OUT} =300mA		125	200	
		I _{OUT} =600mA		250	400	
Quiescent Current	I _Q	V _{IN} =4.3V, I _{OUT} =0mA		55	80	μA
Standby Current	I _{STD}	V _{IN} =4.3V, V _{EN} in OFF mode		0.01	1.0	μA
Power Supply Rejection Ratio	PSRR	Ripple 0.5Vp-p V _{IN} =4.3V, I _{OUT} =100mA	f=100Hz	65		dB
			f=1kHz	65		
Output Voltage Temperature Coefficient	$\frac{(\Delta V_{OUT}/V_{OUT})}{\Delta T}$	I _{OUT} =30mA T _A =-40°C to 85°C		±100		ppm/°C
Short Current Limit	I _{SHORT}	V _{OUT} =0V		50		mA
RMS Output Noise	V _{NOISE}	No Load, 10Hz ≤ f ≤ 100kHz		50		μV _{RMS}
VEN High Voltage	V _{IH}	Enable logic high, regulator on	1.5		6.0	V
VEN Low Voltage	V _{IL}	Enable logic low, regulator off	0		0.4	
Start-up Time	t _S	No Load		20		μs
EN Pull Down Resistor	R _{PD}			3.0		mΩ
VOU _T Discharge Resistor	R _{DCHG}	Set EN pin at Low		60		Ω
Thermal Shutdown Temperature	T _{OTSD}			160		°C
Thermal Shutdown Hysteresis	T _{HYOTSD}			30		
Thermal Resistance (Junction to Case)	θ _{JC}	SOIC-8		74.6		°C/W
		PSOP-8		43.7		
		SOT-223		50.9		

Note 2: To prevent the short circuit current protection feature from being prematurely activated, the input voltage must be applied before a current source load is applied.

Note 3: Production testing at T_A=25°C. Over temperature specifications guaranteed by design only.



600mA CMOS LDO REGULATOR WITH ENABLE

AP2111

Electrical Characteristics (Continued)

AP2111-4.8 Electrical Characteristic (Note 2) (Only for SOT-223)

$V_{IN}=5.5V$, $C_{IN}=1\mu F$ (Ceramic), $C_{OUT}=1\mu F$ (Ceramic), Typical $T_A=25^\circ C$, **Bold** typeface applies over $-40^\circ C \leq T_A \leq 85^\circ C$ ranges, unless otherwise specified (Note 3).

Parameter	Symbol	Conditions	Min	Typ	Max	Unit
Output Voltage	V_{OUT}	$V_{IN}=5.5V$, $1mA \leq I_{OUT} \leq 30mA$	$\frac{V_{OUT}}{\times 98.5\%}$	4.8	$\frac{V_{OUT}}{\times 101.5\%}$	V
Maximum Output Current	$I_{OUT(Max)}$	$V_{IN}=5.5V$, $V_{OUT}=4.751V$ to $4.850V$	600			mA
Load Regulation	$\frac{(\Delta V_{OUT}/V_{OUT})}{\Delta I_{OUT}}$	$V_{IN}=5.5V$, $1mA \leq I_{OUT} \leq 600mA$		0.2		%/A
Line Regulation	$\frac{(\Delta V_{OUT}/V_{OUT})}{\Delta V_{IN}}$	$5.5V \leq V_{IN} \leq 6V$, $I_{OUT}=30mA$		0.02		%/V
Dropout Voltage	V_{DROP}	$I_{OUT}=10mA$		5	8	mV
		$I_{OUT}=300mA$		100	200	
		$I_{OUT}=600mA$		200	400	
Quiescent Current	I_Q	$V_{IN}=5.5V$, $I_{OUT}=0mA$		55	80	μA
Standby Current	I_{STD}	$V_{IN}=5.5V$, V_{EN} in OFF mode		0.01	1.0	μA
Power Supply Rejection Ratio	PSRR	Ripple 0.5Vp-p $V_{IN}=5.5V$, $I_{OUT}=100mA$	$f=100Hz$	65		dB
			$f=1kHz$	65		
Output Voltage Temperature Coefficient	$\frac{(\Delta V_{OUT}/V_{OUT})}{\Delta T}$	$I_{OUT}=30mA$ $T_A=-40^\circ C$ to $85^\circ C$		± 100		ppm/ $^\circ C$
Short Current Limit	I_{SHORT}	$V_{OUT}=0V$		50		mA
RMS Output Noise	V_{NOISE}	No Load, $10Hz \leq f \leq 100kHz$		50		μV_{RMS}
Thermal Shutdown Temperature	T_{OTSD}			160		$^\circ C$
Thermal Shutdown Hysteresis	T_{HYOTSD}			30		
Thermal Resistance (Junction to Case)	θ_{JC}	SOT-223		50.9		

Note 2: To prevent the short circuit current protection feature from being prematurely activated, the input voltage must be applied before a current source load is applied.

Note 3: Production testing at $T_A=25^\circ C$. Over temperature specifications guaranteed by design only.

**600mA CMOS LDO REGULATOR WITH ENABLE****AP2111****Electrical Characteristics (Continued)****AP2111-ADJ Electrical Characteristic (Note 2) (Only for SOT-23-5)**

$V_{IN}=2.5V$, $C_{IN}=1.0\mu F$ (Ceramic), $C_{OUT}=1.0\mu F$ (Ceramic), Typical $T_A=25^\circ C$, **Bold** typeface applies over $-40^\circ C \leq T_A \leq 85^\circ C$ ranges, unless otherwise specified (Note 3).

Parameter	Symbol	Conditions	Min	Typ	Max	Unit
Reference Voltage	V_{REF}	$V_{IN}=2.5V$, $1mA \leq I_{OUT} \leq 30mA$	$\frac{V_{REF}}{\times 98.5\%}$	0.8	$\frac{V_{REF}}{\times 101.5\%}$	V
Maximum Output Current	$I_{OUT(Max)}$	$V_{IN}=2.5V$, $V_{REF}=0.788V$ to $0.812V$	600			mA
Load Regulation	$\frac{(\Delta V_{OUT}/V_{OUT})}{\Delta I_{OUT}}$	$V_{IN}=2.5V$, $1mA \leq I_{OUT} \leq 600mA$		0.2		%/A
Line Regulation	$\frac{(\Delta V_{OUT}/V_{OUT})}{\Delta V_{IN}}$	$2.5V \leq V_{IN} \leq 6V$, $I_{OUT}=30mA$		0.02		%/V
Quiescent Current	I_Q	$V_{IN}=2.5V$, $I_{OUT}=0mA$		55	80	μA
Standby Current	I_{STD}	$V_{IN}=2.5V$, V_{EN} in OFF mode		0.01	1.0	μA
Power Supply Rejection Ratio	PSRR	Ripple 0.5Vp-p $V_{IN}=2.5V$, $I_{OUT}=100mA$	$f=100Hz$	65		dB
			$f=1kHz$	65		
Output Voltage Temperature Coefficient	$\frac{(\Delta V_{OUT}/V_{OUT})}{\Delta T}$	$I_{OUT}=30mA$ $T_A=-40^\circ C$ to $85^\circ C$		± 100		ppm/ $^\circ C$
Short Current Limit	I_{SHORT}	$V_{OUT}=0V$		50		mA
RMS Output Noise	V_{NOISE}	No Load, $10Hz \leq f \leq 100kHz$		50		μV_{RMS}
VEN High Voltage	V_{IH}	Enable logic high, regulator on	1.5		6.0	V
VEN Low Voltage	V_{IL}	Enable logic low, regulator off	0		0.4	
Start-up Time	t_s	No Load		20		μs
EN Pull Down Resistor	R_{PD}			3.0		m Ω
VOUT Discharge Resistor	R_{DCHG}	Set EN pin at Low		60		Ω
Thermal Shutdown Temperature	T_{OTSD}			160		$^\circ C$
Thermal Shutdown Hysteresis	T_{HYOTSD}			30		
Thermal Resistance (Junction to Case)	θ_{JC}	SOT-23-5		150		$^\circ C/W$

Note 2: To prevent the Short Circuit Current protection feature from being prematurely activated, the input voltage must be applied before a current source load is applied.

Note 3: Production testing at $T_A=25^\circ C$. Over temperature specifications guaranteed by design only.

Typical Performance Characteristics

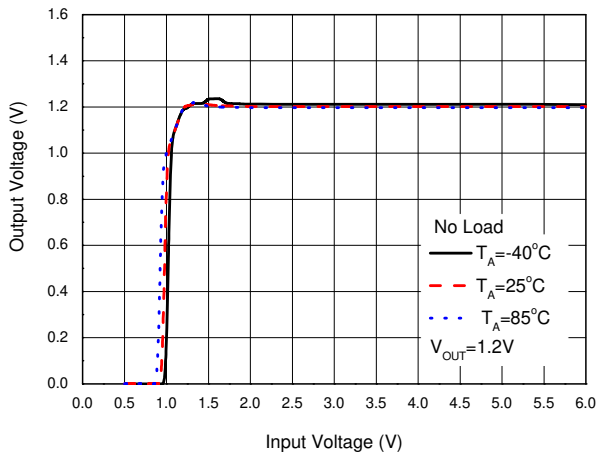

Figure 5. Output Voltage vs. Input Voltage

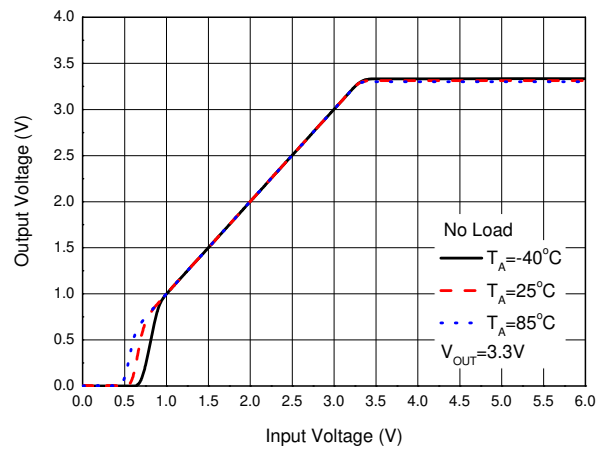

Figure 6. Output Voltage vs. Input Voltage

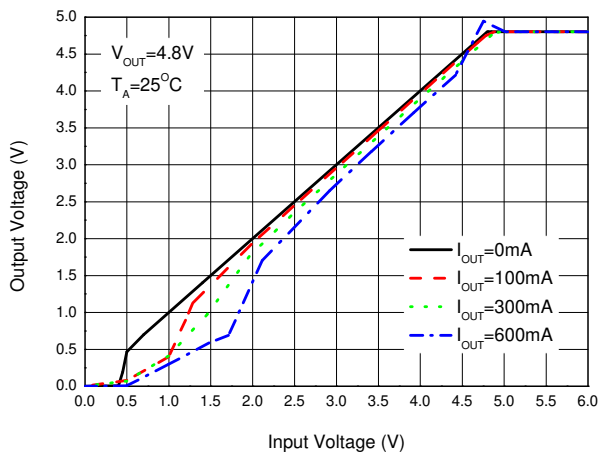

Figure 7. Output Voltage vs. Input Voltage

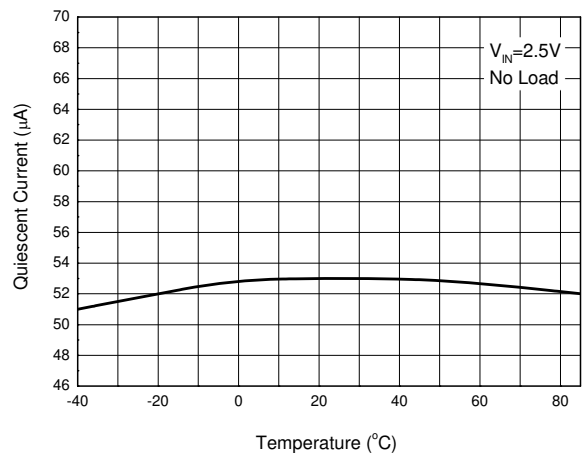

Figure 8. Quiescent Current vs. Temperature

Typical Performance Characteristics (Continued)

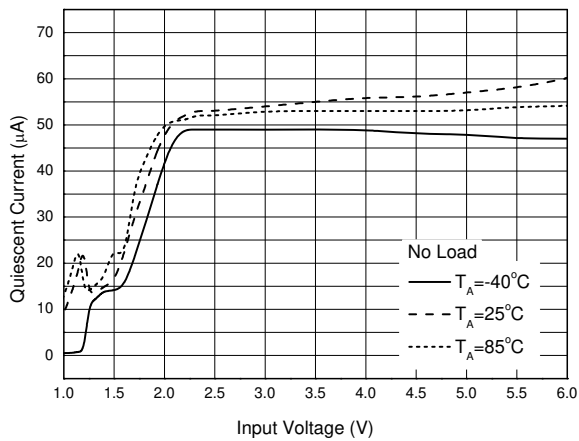

Figure 9. Quiescent Current vs. Input Voltage

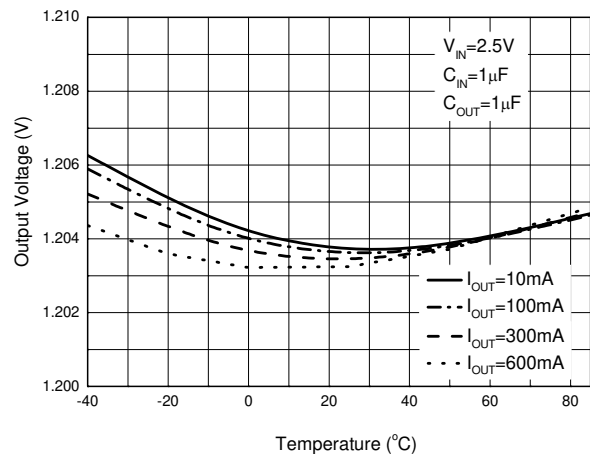

Figure 10. Output Voltage vs. Temperature

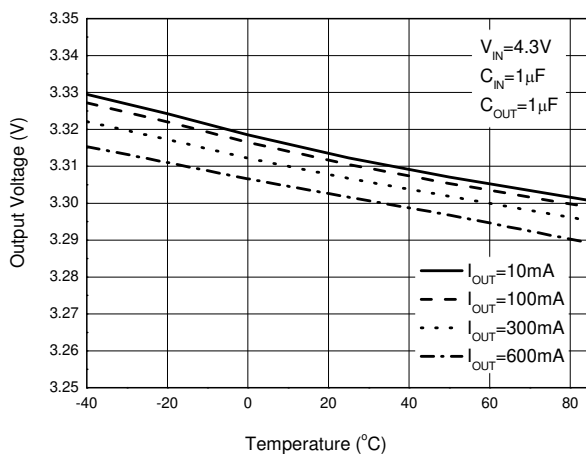

Figure 11. Output Voltage vs. Temperature

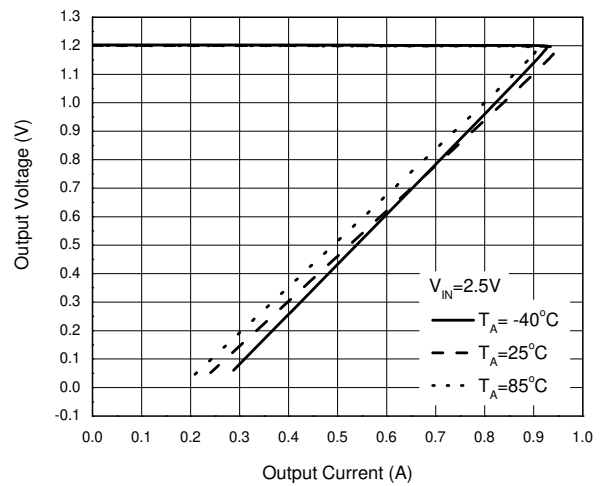

Figure 12. Output Voltage vs. Output Current

Typical Performance Characteristics (Continued)

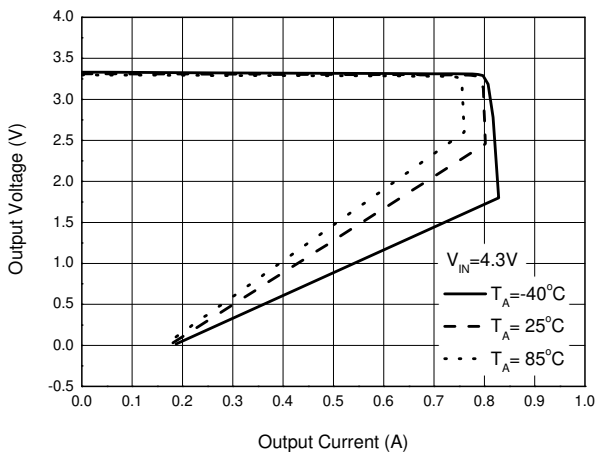

Figure 13. Output Voltage vs. Output Current

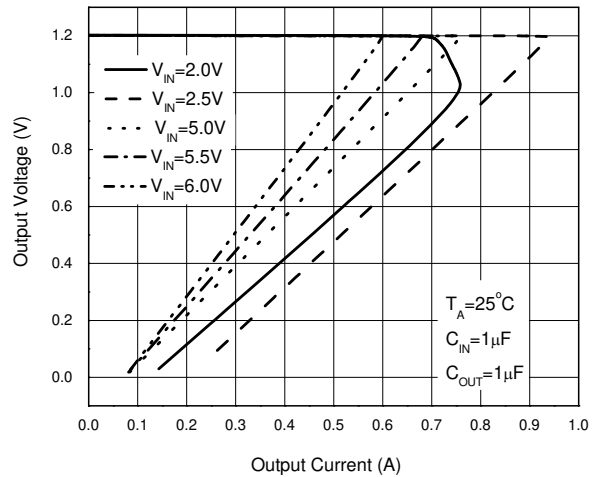

Figure 14. Output Voltage vs. Output Current

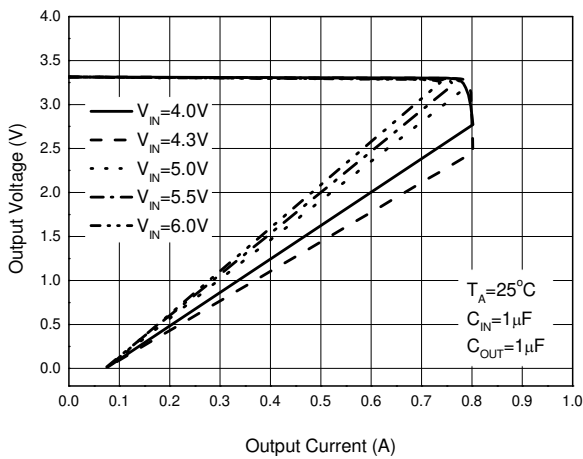

Figure 15. Output Voltage vs. Output Current

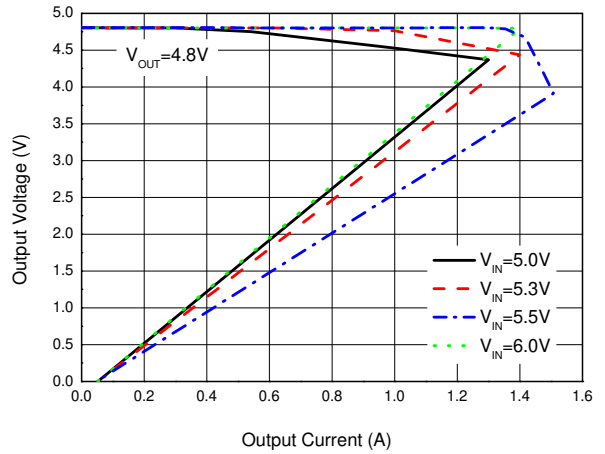

Figure 16. Output Voltage vs. Output Current

Typical Performance Characteristics (Continued)

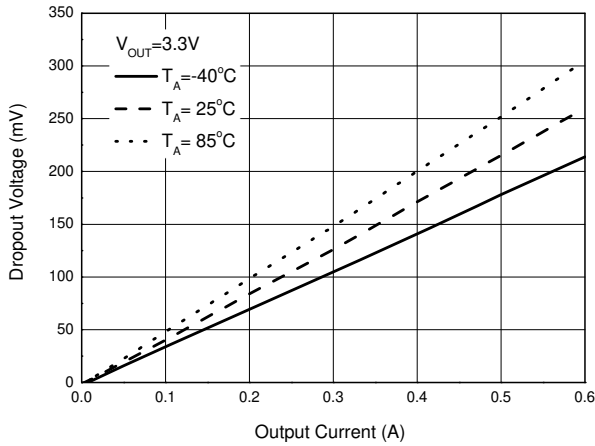

Figure 17. Dropout Voltage vs. Output Current

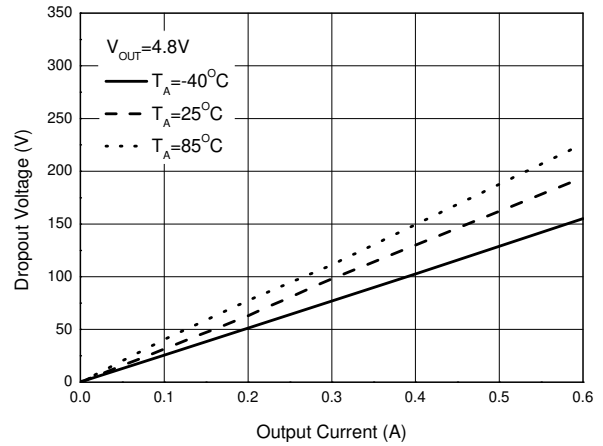

Figure 18. Dropout Voltage vs. Output Current

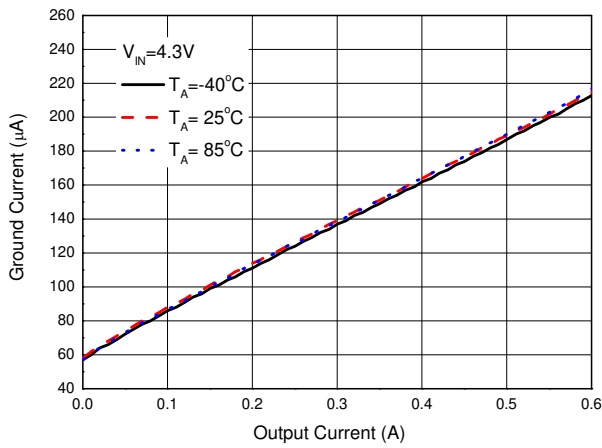

Figure 19. Ground Current vs. Output Current

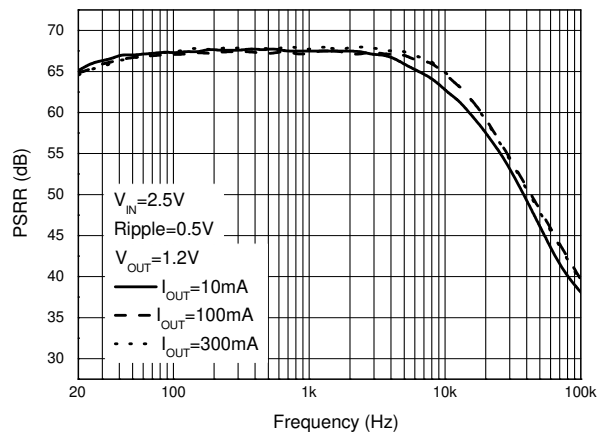

Figure 20. PSRR vs. Frequency

Typical Performance Characteristics (Continued)

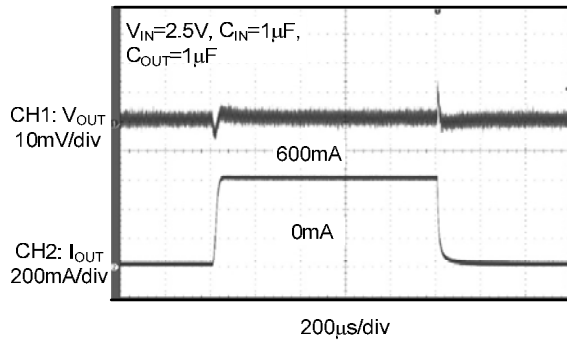

Figure 21. Load Transient

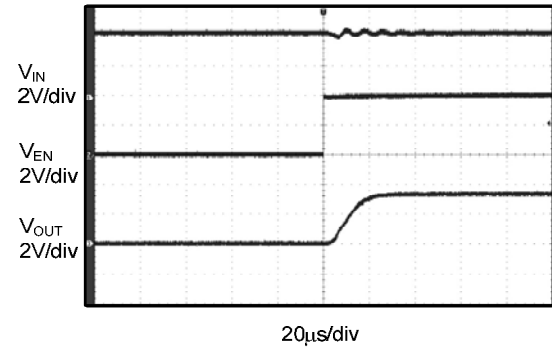

Figure 22. Enable On

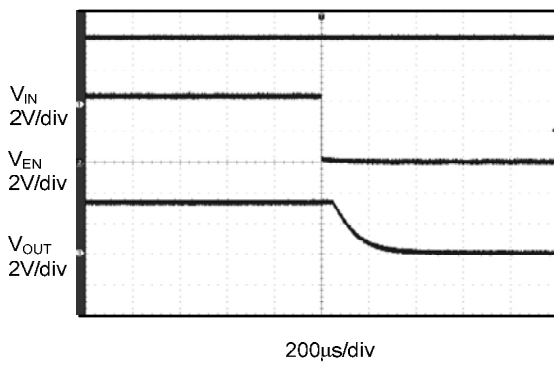
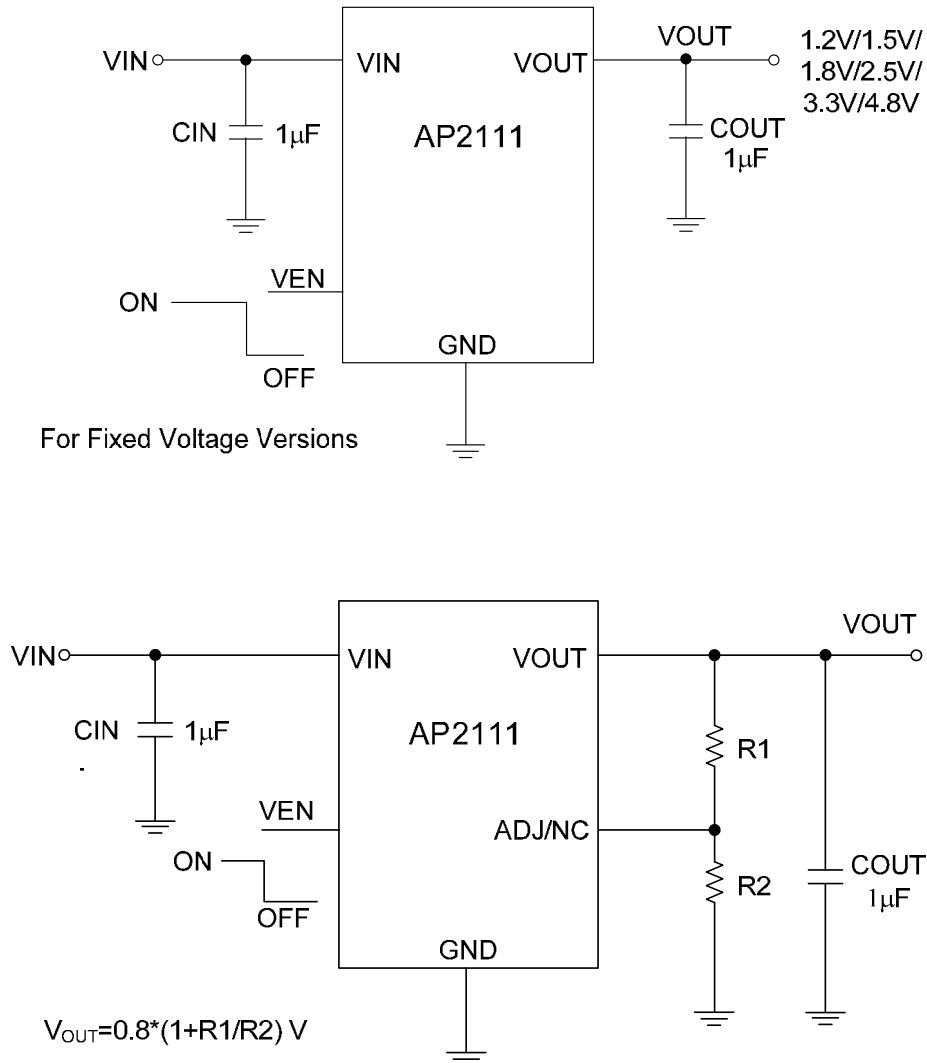

Figure 23. Enable Off

Typical Application (Note 4)

Note 4: It is recommended to use X7R or X5R dielectric capacitor if 1.0µF ceramic capacitor is selected as input/output capacitors.

Figure 24. Typical Application of AP2111

Mechanical Dimensions (Continued)

PSOP-8

Unit: mm(inch)

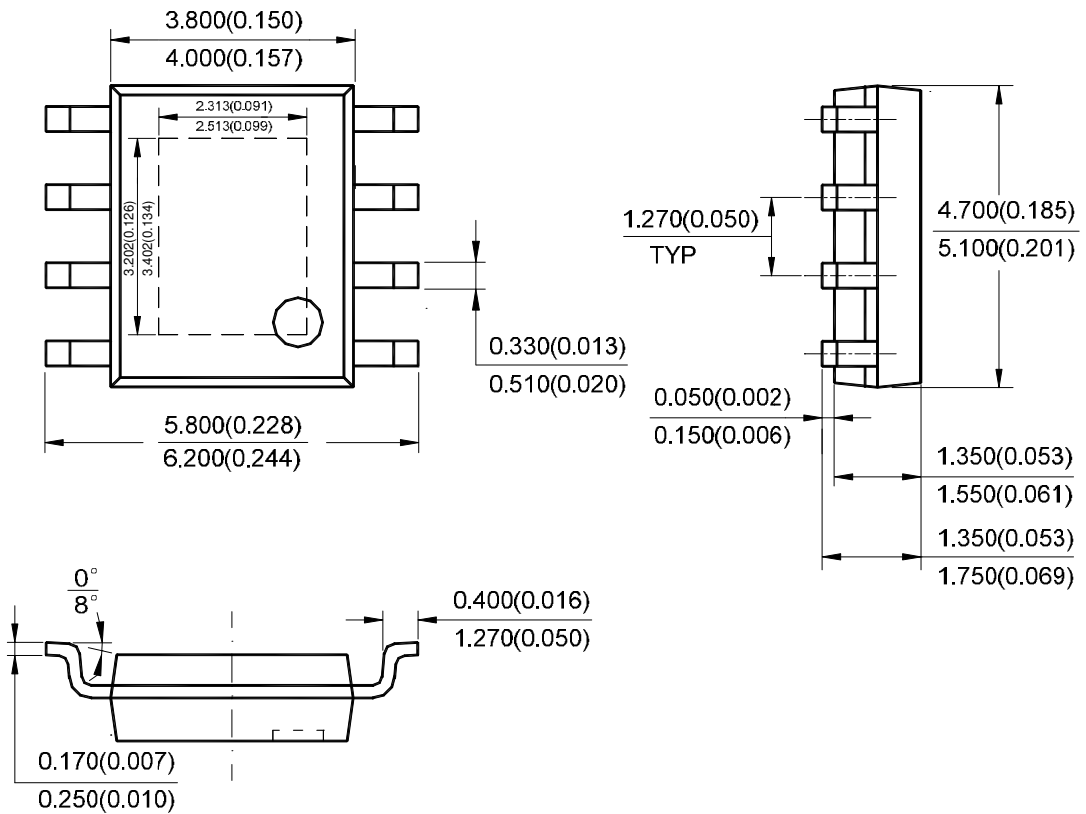

Note: Eject hole, oriented hole and mold mark is optional.

Mechanical Dimensions (Continued)

SOT-223

Unit: mm(inch)

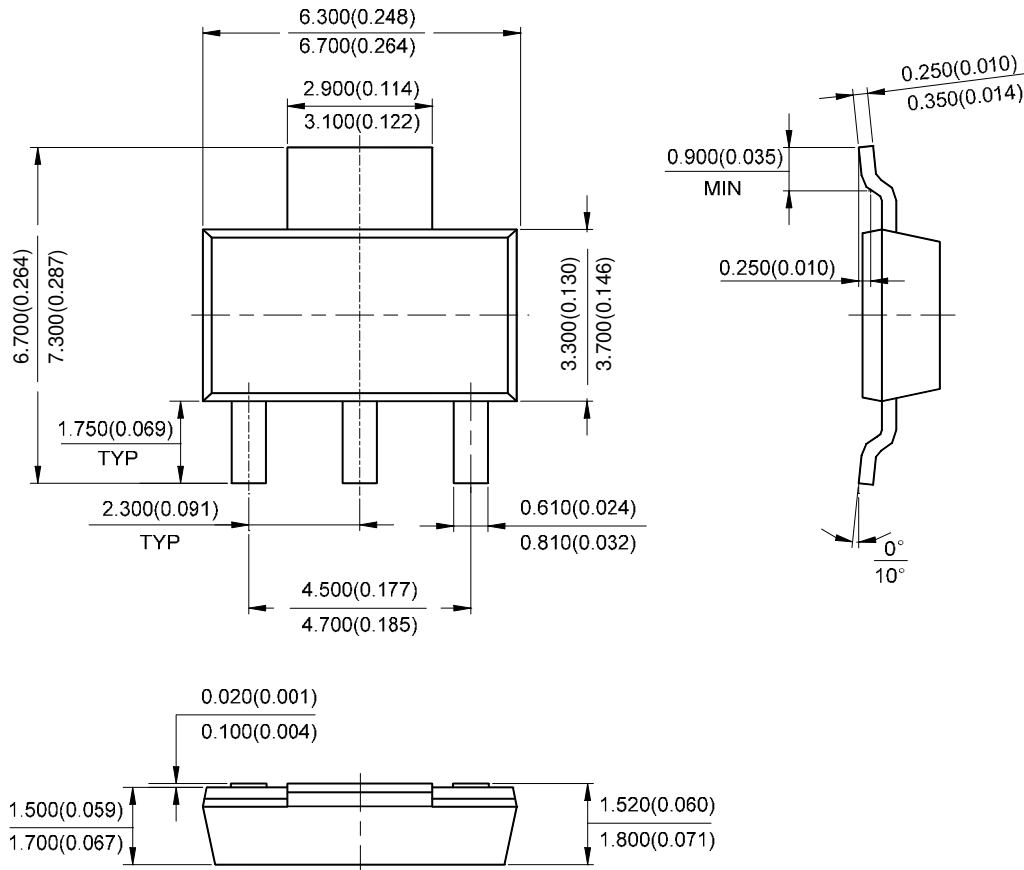

Mechanical Dimensions (Continued)

SOT-23-5

Unit: mm(inch)

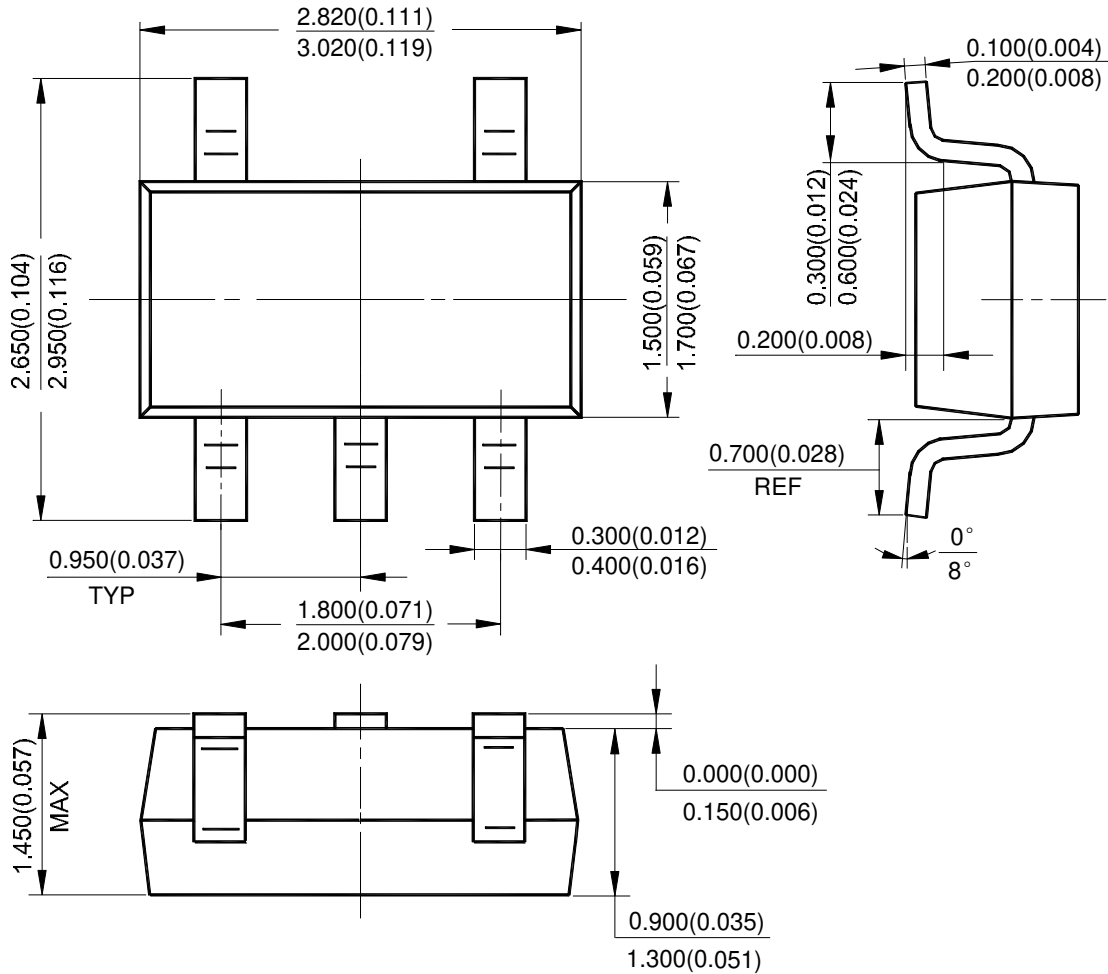



BCD Semiconductor Manufacturing Limited

<http://www.bcdsemi.com>

IMPORTANT NOTICE

BCD Semiconductor Manufacturing Limited reserves the right to make changes without further notice to any products or specifications herein. BCD Semiconductor Manufacturing Limited does not assume any responsibility for use of any its products for any particular purpose, nor does BCD Semiconductor Manufacturing Limited assume any liability arising out of the application or use of any its products or circuits. BCD Semiconductor Manufacturing Limited does not convey any license under its patent rights or other rights nor the rights of others.

MAIN SITE

- Headquarters

BCD Semiconductor Manufacturing Limited

No. 1600, Zi Xing Road, Shanghai Zizhu Science-based Industrial Park, 200241, China
Tel: +86-21-24162266, Fax: +86-21-24162277

- Wafer Fab

Shanghai SIM-BCD Semiconductor Manufacturing Co., Ltd.

800 Yi Shan Road, Shanghai 200233, China
Tel: +86-21-6485 1491, Fax: +86-21-5450 0008

REGIONAL SALES OFFICE

Shenzhen Office

Shanghai SIM-BCD Semiconductor Manufacturing Co., Ltd., Shenzhen Office

Unit A Room 1203, Skyworth Bldg., Gaoxin Ave. 1.S., Nanshan District, Shenzhen, China
Tel: +86-755-8826 7951
Fax: +86-755-8826 7865

Taiwan Office

BCD Semiconductor (Taiwan) Company Limited

4F, 298-1, Rui Guang Road, Nei-Hu District, Taipei, Taiwan
Tel: +886-2-2656 2808
Fax: +886-2-2656 2806

USA Office

BCD Semiconductor Corp.

30920 Huntwood Ave. Hayward, CA 94544, USA
Tel : +1-510-324-2988
Fax: +1-510-324-2788