



Crystal Devices 2023



Products			Dimensions (mm)			Applications				
Product Type	Page No.	Part Number	L	W	T (max.)	Digital Electronics OA, PC Peripherals Amusement	Car Electronics, ITS, Car Audio, Car Navigation	Car Electronics (ECU, Air Bag, ABS, TPMS etc.)	Mobile Comm. Wireless LAN Dedicated Short Range Comm. (DSRC)	Industrial Use (Broadcast, Medical, Base Station etc.)
Crystal Units	3	CT1612RB	1.6	1.2	0.65				○	
	4	CT2016DB (Low Profile)	2.0	1.6	0.65				○	
	4	CT2016DB	2.0	1.6	1.0				○	
	5	CX1008SB	1.0	0.8	0.3	○			○	
	6	CX1210DB	1.2	1.0	0.3	○			○	
	7	CX1210SB	1.2	1.0	0.35	○			○	
	8	CX1612DB	1.6	1.2	0.33/0.4	○			○	
	9	CX2016DB	2.0	1.6	0.45	○				
	10	CX2016SA	2.0	1.6	0.5	○	○	○		
	11	CX3225SA (for Automotive)	3.2	2.5	0.8		○	○		
	12	CX3225GA (for Automotive)	3.2	2.5	0.95		○	○		
	Clock Oscillators (SPXO)	15-16	KC2016Z (X type)	2.0	1.6	0.8	○			○
15,17		KC2016Z (Y type)	2.0	1.6	0.8	○			○	○
15-16		KC2520Z (X type)	2.5	2.0	0.8	○			○	○
15,17		KC2520Z (Y type)	2.5	2.0	0.8	○			○	○
15-16		KC3225Z (X type)	3.2	2.5	0.8	○			○	○
15,17		KC3225Z (Y type)	3.2	2.5	0.8	○			○	○
15-16		KC5032Z (X type)	5.0	3.2	1.2	○			○	○
15,17		KC5032Z (Y type)	5.0	3.2	1.2	○			○	○
15-16		KC7050Z (X type)	7.0	5.0	1.2	○			○	○
15,17		KC7050Z (Y type)	7.0	5.0	1.2	○			○	○
18-19		MC2016Z (X type)	2.0	1.6	0.8		○			
18,20		MC2016Z (Y type)	2.0	1.6	0.8		○			
18-19		MC2520Z (X type)	2.5	2.0	0.8		○			
18,20		MC2520Z (Y type)	2.5	2.0	0.8		○			
18-19		MC3225Z (X type)	3.2	2.5	0.8		○			
18,20		MC3225Z (Y type)	3.2	2.5	0.8		○			
18-19		MC5032Z (X type)	5.0	3.2	1.2		○			
18,20		MC5032Z (Y type)	5.0	3.2	1.2		○			
18-19		MC7050Z (X type)	7.0	5.0	1.2		○			
18,20		MC7050Z (Y type)	7.0	5.0	1.2		○			
21-23		KC2016K	2.0	1.6	0.8	○			○	○
21-23		KC2520K	2.5	2.0	0.8	○			○	○
21-23		KC3225K	3.2	2.5	0.8	○			○	○
21-23		KC5032K	5.0	3.2	1.2	○			○	○
21-23		KC7050K	7.0	5.0	1.2	○			○	○
24-26		MC2016K	2.0	1.6	0.8		○			
24-26		MC2520K	2.5	2.0	0.8		○			
24-26		MC3225K	3.2	2.5	0.8		○			
24-26		MC5032K	5.0	3.2	1.2		○			
24-26		MC7050K	7.0	5.0	1.2		○			
Temperature Compensated Crystal Oscillators (TCXO)	27	KT1612A (Low Phase Noise)	1.65	1.25	0.55	○			○	○
	28	KT1612A	1.65	1.25	0.55	○			○	○
	29	KT2016K	2.0	1.6	0.8	○	○		○	○
	30	KT2520K	2.5	2.0	0.8	○	○		○	○
	31	KT5032F	5.0	3.2	1.7					○
	32	KT7050	7.0	5.0	1.7					○

NR = Not recommended

Products	Frequency Range (MHz)					Conditions of Use				RoHS Compliant*	AEC		
	Part Number	1	10	50	100	300 to 800	Solder				Washable	Q100	Q200
							Manual	Reflow	Flow				
CT1612RB				38.4		76.8	Yes	Yes	No	Yes	Yes		
CT2016DB (Low Profile)		19.2		38.4			Yes	Yes	No	Yes	Yes		
CT2016DB		19.2		38.4			Yes	Yes	No	Yes	Yes		
CX1008SB				37.4		80	Yes	Yes	No	Yes	Yes		
CX1210DB				37.4		80	Yes	Yes	No	Yes	Yes		
CX1210SB			27.12	32	48	76.8	Yes	Yes	No	Yes	Yes		
CX1612DB			24		48		Yes	Yes	No	Yes	Yes		
CX2016DB			16		50		Yes	Yes	No	Yes	Yes		
CX2016SA			16		50		Yes	Yes	No	Yes	Yes	Yes	
CX3225SA (for Automotive)		8		40			Yes	Yes	No	Yes	Yes	Yes	
CX3225GA (for Automotive)		8		40			Yes	Yes	No	Yes	Yes	Yes	
KC2016Z (X type)	0.5					170	No	Yes	No	NR	Yes		
KC2016Z (Y type)		24		72			No	Yes	No	NR	Yes		
KC2520Z (X type)	0.5					170	No	Yes	No	NR	Yes		
KC2520Z (Y type)		24		72			No	Yes	No	NR	Yes		
KC3225Z (X type)	0.5					170	No	Yes	No	NR	Yes		
KC3225Z (Y type)		24		72			No	Yes	No	NR	Yes		
KC5032Z (X type)	0.5					170	No	Yes	No	NR	Yes		
KC5032Z (Y type)		24		72			No	Yes	No	NR	Yes		
KC7050Z (X type)	0.5					170	No	Yes	No	NR	Yes		
KC7050Z (Y type)		24		72			No	Yes	No	NR	Yes		
MC2016Z (X type)	0.5					170	No	Yes	No	NR	Yes	Yes (option)	
MC2016Z (Y type)		24		72			No	Yes	No	NR	Yes	Yes (option)	
MC2520Z (X type)	0.5					170	No	Yes	No	NR	Yes	Yes (option)	
MC2520Z (Y type)		24		72			No	Yes	No	NR	Yes	Yes (option)	
MC3225Z (X type)	0.5					170	No	Yes	No	NR	Yes	Yes (option)	
MC3225Z (Y type)		24		72			No	Yes	No	NR	Yes	Yes (option)	
MC5032Z (X type)	0.5					170	No	Yes	No	NR	Yes	Yes (option)	
MC5032Z (Y type)		24		72			No	Yes	No	NR	Yes	Yes (option)	
MC7050Z (X type)	0.5					170	No	Yes	No	NR	Yes	Yes (option)	
MC7050Z (Y type)		24		72			No	Yes	No	NR	Yes	Yes (option)	
KC2016K	1.5					160	No	Yes	No	NR	Yes		
KC2520K	1.5					160	No	Yes	No	NR	Yes		
KC3225K	1.5					160	No	Yes	No	NR	Yes		
KC5032K	1.5					160	No	Yes	No	NR	Yes		
KC7050K	1.5					160	No	Yes	No	NR	Yes		
MC2016K	1.5					160	No	Yes	No	NR	Yes	Yes (option)	
MC2520K	1.5					160	No	Yes	No	NR	Yes	Yes (option)	
MC3225K	1.5					160	No	Yes	No	NR	Yes	Yes (option)	
MC5032K	1.5					160	No	Yes	No	NR	Yes	Yes (option)	
MC7050K	1.5					160	No	Yes	No	NR	Yes	Yes (option)	
KT1612A (Low Phase Noise)		19.2		76.8			No	Yes	No	No	Yes		
KT1612A		19.2		76.8			No	Yes	No	No	Yes		
KT2016K		19.2		52.0			No	Yes	No	No	Yes	Yes (option)	
KT2520K		19.2		52.0			No	Yes	No	No	Yes	Yes (option)	
KT5032F		10		40			Contact us	Yes	No	No	Yes		
KT7050		10		40			Contact us	Yes	No	No	Yes		

* RoHS Compliant Products : Products which do not contain lead, cadmium, mercury, hexavalent chromium, PBB, PBDE, DEHP, BBP, DBP and DIBP, based on EU DIRECTIVE 2015/863/EU. Substances exempted by the DIRECTIVE and impurities observed in the natural environment are excepted.



1.6x1.2mm for Mobile Communications



RoHS Compliant

Features

- Crystal Unit with Thermistor
- Reference frequency for telecommunication systems
- Reflow compatible
- Using ceramic package resulting in high reliability

Applications

- Mobile Communications, GNSS

How to Order

CT1612RB 38400 □□ □ □ □ □
① ② ③ ④ ⑤ ⑥ ⑦

①Series

②Frequency

③Load Capacitance

④Frequency Tolerance

B0	6 pF	—	F	$\pm 10 \times 10^{-6}$	Std.
C0	7 pF	—	G	$\pm 15 \times 10^{-6}$	—
D0	8 pF	Std.			

⑤Operating Temp. Range ⑥Frequency Temp. Stability

LH	-30 to +85°C	$\pm 12 \times 10^{-6}$ (at -30 to +85°C)
----	--------------	---

⑦Individual Specification

Packaging (Tape & Reel 15000 pcs./ reel)

Specifications

Item	Symbol	Specification	Unit	Remarks
Frequency Range	f _{nom}	38400 to 76800	kHz	
Overtone Order	OT	Fundamental	—	
Load Capacitance	CL	8	pF	Please contact us for other CL requirements.
Frequency Tolerance	f _{tol}	± 10	$\times 10^{-6}$	25°C ± 3 °C
Motional Series Resistance	R1	Table 1	ohm	
Drive Level	DL	10	μ W	100 μ W max.
Operating Temp. Range	T _{use}	-30 to +85	°C	
Storage Temp. Range	T _{stg}	-40 to +105	°C	
Frequency Temp. Characteristics	f _{tem}	± 12	$\times 10^{-6}$	
Thermistor Resistance	—	Table 2	ohm	25°C ± 3 °C
Thermistor B-Constant	—	Table 3	K	25°C to 50°C

Table 1 Motional Series Resistance

Frequency Range	Motional Series Resistance
38400 to 76800kHz	50 Ω max.

Table 2 Thermistor Resistance

Resistance	Specification
100k Ω	$\pm 1\%$

Table 3 Thermistor B-Constant

B-Constant	Specification
4250K	$\pm 1\%$

Please contact us for other specifications.

Dimensions

(Unit: mm)

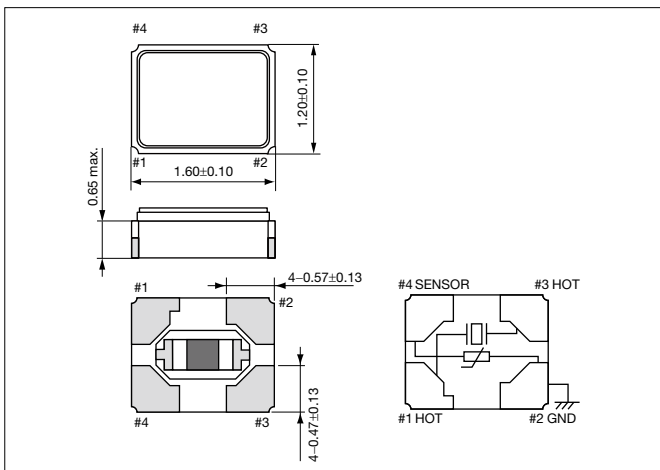

Recommended Land Pattern

(Unit: mm)

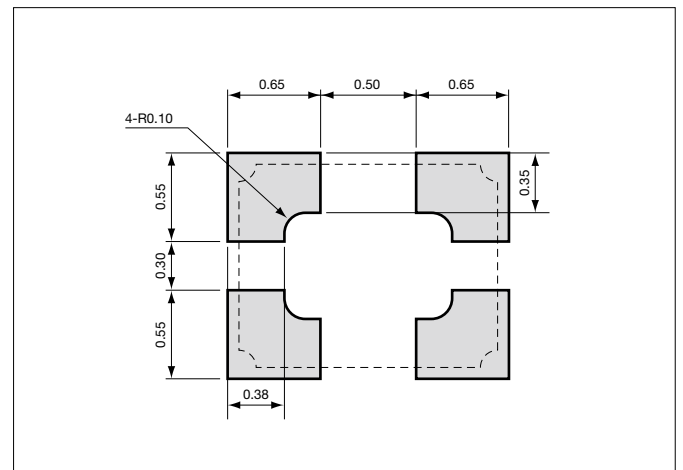



2.0x1.6mm for Mobile Communications

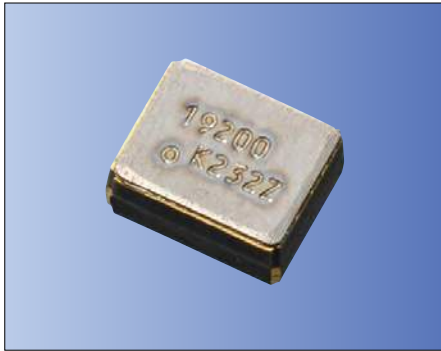

RoHS Compliant

Features

- Crystal Unit with Thermistor
- Height 0.65 (max.) mm is also available
- Reference frequency for telecommunication systems
- Reflow compatible
- Using ceramic package resulting in high reliability

Applications

- Mobile Communications, GNSS

How to Order

CT2016DB 19200 □□ □ □ □ □ □
① ② ③ ④ ⑤ ⑥ ⑦

①Series
②Frequency
③Load Capacitance ④Frequency Tolerance

B0	6 pF	—	F	$\pm 10 \times 10^{-6}$	Std.
C0	7 pF	Std.	G	$\pm 15 \times 10^{-6}$	—

⑤Operating Temp. Range ⑥Frequency Temp. Stability

PF	-40 to +85°C	$\pm 10 \times 10^{-6}$ (at -25 to +85°C)
RH	-40 to +105°C	$\pm 12 \times 10^{-6}$ (at -30 to +85°C)

⑦Individual Specification

Packaging (Tape & Reel 12000 pcs./ reel)

Specifications

Item	Symbol	Specification	Unit	Remarks
Frequency Range	f _{nom}	19200/ 38400	kHz	
Overtone Order	OT	Fundamental	—	
Load Capacitance	CL	7	pF	
Frequency Tolerance	f _{tol}	±10	$\times 10^{-6}$	25°C±3°C
Motional Series Resistance	R1	Table 1	ohm	
Drive Level	DL	10	μW	100μW max.
Operating Temp. Range	T _{use}	-30 to +85	°C	
Storage Temp. Range	T _{stg}	-40 to +105	°C	
Frequency Temp. Characteristics	f _{tem}	±12	$\times 10^{-6}$	Freq. deviation from the value at 32°C
Thermistor Resistance	—	Table 2	ohm	25°C
Thermistor B-Constant	—	Table 3	K	25°C to 50°C

Please contact us for other specifications.

Table 1 Motional Series Resistance

Frequency Range	Motional Series Resistance
19200/ 38400kHz	80 Ω max.

Table 2 Thermistor Resistance

Resistance	Specification
100kΩ	±1%

Table 3 Thermistor B-Constant

B-Constant	Specification
4250K	±1%

Crystal Units

Dimensions

(Unit: mm)

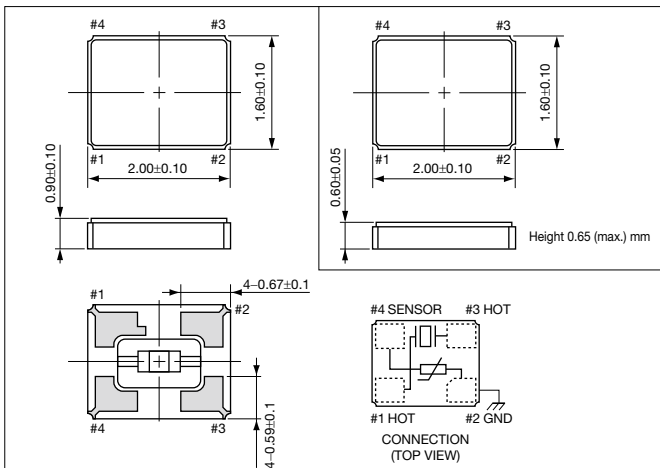

Recommended Land Pattern

(Unit: mm)

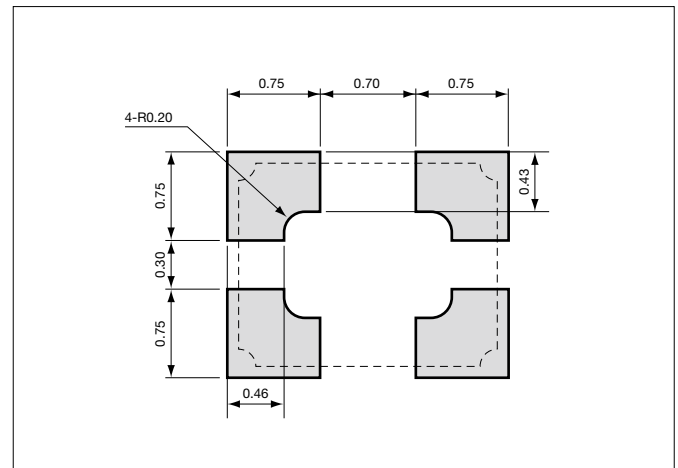



1.0×0.8mm for Consumer Products/ Mobile Communications



RoHS Compliant

Features

- Ultra-miniature and low profile (1.0×0.8×0.3mm max.)
- Crystal unit for mobile communication Systems.
- Reflow compatible
- Using ceramic package resulting in high reliability

Applications

- Mobile Communications

How to Order

CX1008SB 37400 □□ □ □ □ □ □
① ② ③ ④ ⑤ ⑥ ⑦

①Series	②Frequency
③Load Capacitance	④Frequency Tolerance
B0 6 pF —	F ±10×10 ⁻⁶ Std.
C0 7 pF Std.	G ±15×10 ⁻⁶ —
⑤Operating Temp. Range	⑥Frequency Temp. Stability
LH -30 to +85°C	±12×10 ⁻⁶
⑦Individual Specification	

Packaging (Tape & Reel 21000 pcs./ reel)

Specifications

Item	Symbol	Specification	Unit	Remarks
Frequency Range	f _{nom}	37400 to 80000	kHz	
Overtone Order	OT	Fundamental	—	
Load Capacitance	CL	7	pF	Please contact us for other CL requirements.
Frequency Tolerance	f _{tol}	±10	×10 ⁻⁶	25°C±3°C
Motional Series Resistance	R1	Table 1	ohm	
Drive Level	DL	Table 2	μW	
Operating Temp. Range	T _{use}	-30 to +85	°C	
Storage Temp. Range	T _{stg}	-40 to +105	°C	
Frequency Temp. Characteristics	f _{tem}	±12	×10 ⁻⁶	

Please contact us for other specifications.

Crystal Units

Table 1 Motional Series Resistance

Frequency Range	Motional Series Resistance
f _{nom} =37400 to 80000kHz	60 Ω max.

Table 2 Level of Drive

Frequency Range	Level of Drive
f _{nom} =37400 to 80000kHz	10μW (100μW max.)

Dimensions

(Unit: mm)

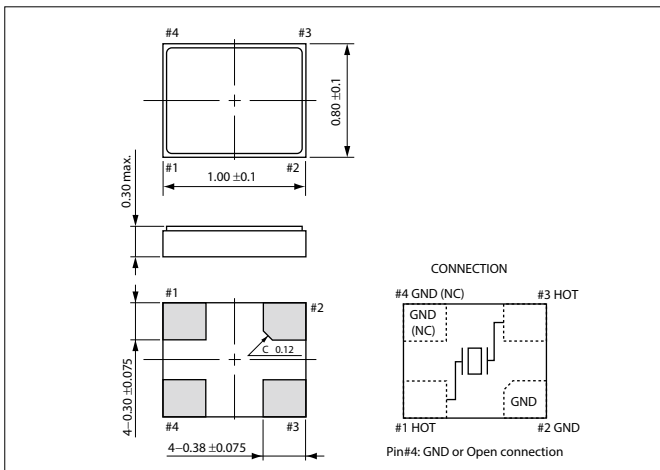

Recommended Land Pattern

(Unit: mm)

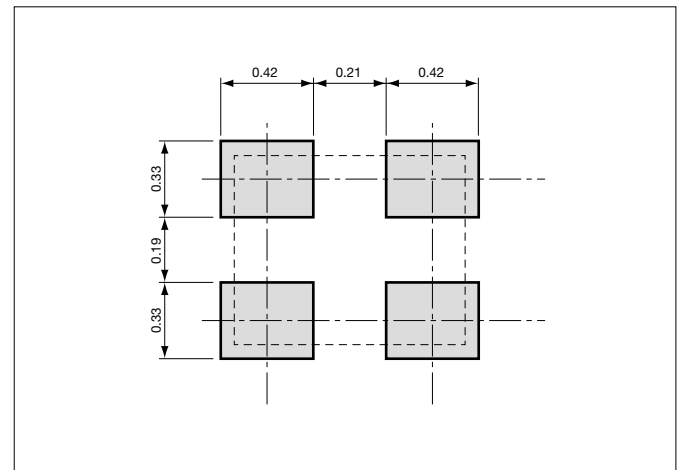



1.2×1.0mm for Consumer Products/ Mobile Communications

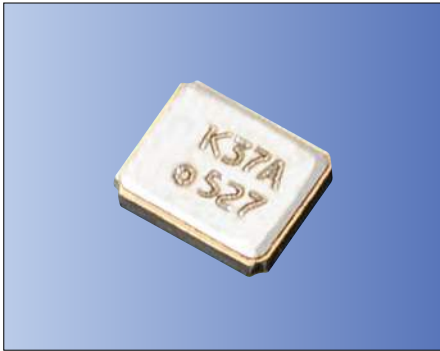

RoHS Compliant

Features

- Ultra-miniature and low profile (1.2×1.0×0.3mm max.)
- Crystal unit for mobile communication Systems.
- Reflow compatible
- Using ceramic package resulting in high reliability

Applications

- Mobile Communications, Bluetooth®, Wireless LAN

* Bluetooth® Trademarks are owned by Bluetooth SIG, Inc.

How to Order

CX1210DB 37400 □□ □ □ □ CC
① ② ③ ④ ⑤ ⑥ ⑦

①Series	②Frequency
③Load Capacitance	④Frequency Stability
D0 8 pF	F ±10×10 ⁻⁶
H0 12 pF	G ±15×10 ⁻⁶

⑤Operating Temp. Range	⑥Frequency Temp. Stability
FF -20 to +70°C	±10×10 ⁻⁶
LH -30 to +85°C	±12×10 ⁻⁶
LJ -30 to +85°C	±15×10 ⁻⁶

⑦Individual Specification (STD Specification is "CC".)

Packaging (Tape & Reel 1000/ 3000/ 12000/ 21000pcs./ reel)

Specifications

Item	Symbol	Specification	Unit	Remarks
Frequency Range	f _{nom}	37400/ 40000/ 52000/ 80000	kHz	
Overtone Order	OT	Fundamental	—	
Load Capacitance	CL	8	pF	
Frequency Tolerance	f _{tol}	±10	×10 ⁻⁶	25°C±3°C
Motional Series Resistance	R1	Table 1	ohm	
Drive Level	DL	Table 2	μW	
Operating Temp. Range	T _{use}	-30 to +85	°C	
Storage Temp. Range	T _{stg}	-40 to +105	°C	
Frequency Temp. Characteristics	f _{tem}	±12	×10 ⁻⁶	Freq. deviation from the value at 25°C

Please contact us for other specifications.

Table 1 Motional Series Resistance

Frequency Range	Motional Series Resistance
f _{nom} =37400/ 40000/ 52000/ 80000kHz	60 Ω max.

Table 2 Level of Drive

Frequency Range	Level of Drive
f _{nom} =37400/ 40000/ 52000/ 80000kHz	10μW (100μW max.)

Dimensions

(Unit: mm)

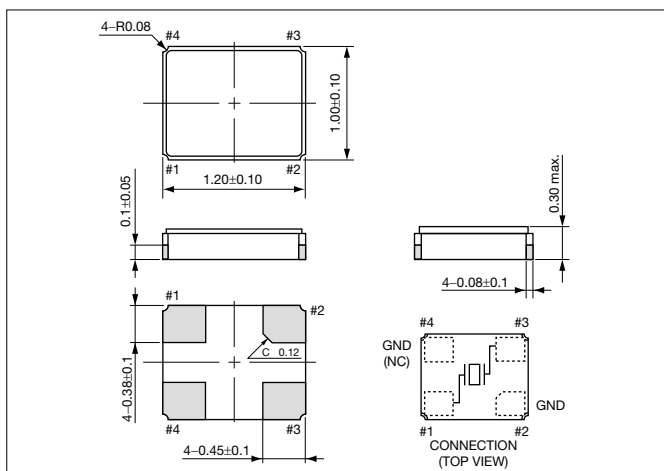

Recommended Land Pattern

(Unit: mm)

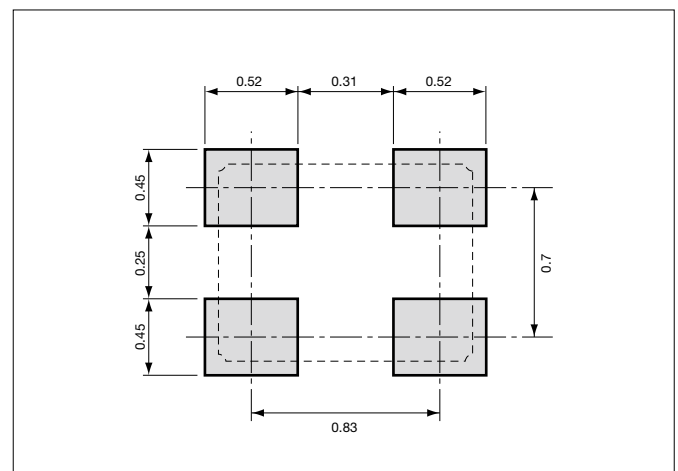



1.2×1.0mm for Consumer Products/ Mobile Communications



Features

- Ultra-miniature and low profile (1.2×1.0×0.35mm max.)
- Crystal unit for mobile communication Systems.
- Reflow compatible
- Using ceramic package resulting in high reliability

Applications

- Mobile Communications, Bluetooth®, Wireless LAN

* Bluetooth® Trademarks are owned by Bluetooth SIG, Inc.

How to Order

CX1210SB 27120 □□ □ □ □ CC
① ② ③ ④ ⑤ ⑥ ⑦

①Series	②Frequency
③Load Capacitance	④Frequency Stability
B0 6 pF	F ±10×10 ⁻⁶
D0 8 pF	G ±15×10 ⁻⁶

⑤Operating Temp. Range	⑥Frequency Temp. Stability
FF -20 to +70°C	±10×10 ⁻⁶
LH -30 to +85°C	±12×10 ⁻⁶
LJ -30 to +85°C	±15×10 ⁻⁶

⑦Individual Specification (STD Specification is "CC".)

Packaging (Tape & Reel 1000/ 3000/ 12000/ 21000pcs./ reel)

Specifications

Item	Symbol	Specification	Unit	Remarks
Frequency Range	f _{nom}	27120/ 32000/ 48000/ 76800	kHz	
Overtone Order	OT	Fundamental	—	
Load Capacitance	CL	8	pF	
Frequency Tolerance	f _{tol}	±10	×10 ⁻⁶	25°C±3°C
Motional Series Resistance	R1	Table 1	ohm	
Drive Level	DL	Table 2	μW	
Operating Temp. Range	T _{use}	-30 to +85	°C	
Storage Temp. Range	T _{stg}	-40 to +105	°C	
Frequency Temp. Characteristics	f _{tem}	±12	×10 ⁻⁶	Freq. deviation from the value at 25°C

Please contact us for other specifications.

Crystal Units

Table 1 Motional Series Resistance

Frequency Range	Motional Series Resistance
f _{nom} =27120kHz	100 Ω max.
f _{nom} =32000kHz	60 Ω max.

Table 2 Level of Drive

Frequency Range	Level of Drive
f _{nom} =27120/ 32000kHz	10μW (100μW max.)

Dimensions

(Unit: mm)

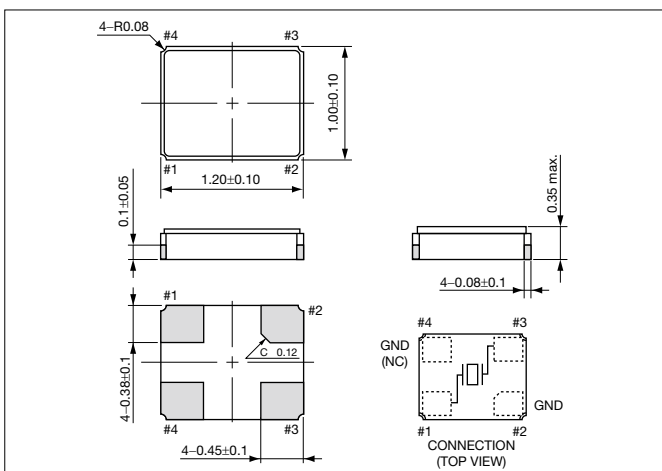

Recommended Land Pattern

(Unit: mm)

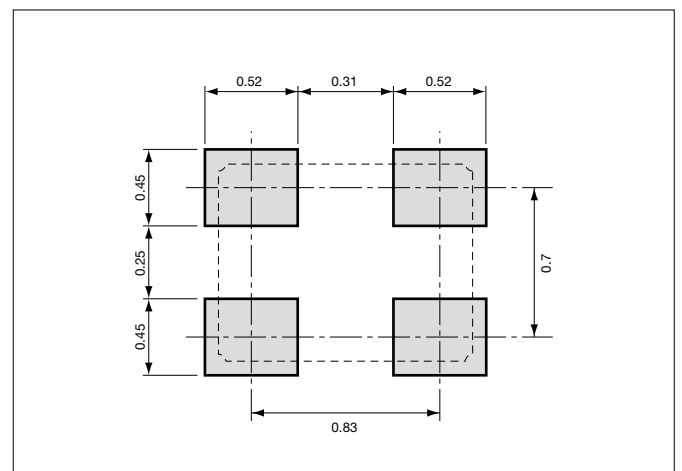



1.6x1.2mm for Consumer Products/ Mobile Communications



RoHS Compliant

Features

- Crystal unit for Digital Electronics and Consumer Products
- Ultra-miniature and low profile
32000kHz or more accepts 0.33mm-high
- Ceramic package
- Reflow compatible

Applications

- Smartphone (Bluetooth®, Wireless LAN, NFC)
- Wearable devices
- Short range wireless (LPWA)

* Bluetooth® Trademarks are owned by Bluetooth SIG, Inc.

How to Order

CX1612DB 24000 □□ G L L CC
① ② ③ ④ ⑤ ⑥ ⑦

- ① Series
- ② Frequency
- ③ Load Capacitance
- ④ Frequency Tolerance
- ⑤ Operating Temp. Range
- ⑥ Frequency Temp. Stability
- ⑦ Individual Specification (STD Specification is "CC".)

Example: D0 8 pF G ±15×10⁻⁶ LL -30 to +85°C ±20×10⁻⁶

Ⓣ Packaging (Tape & Reel 3000/ 20000 pcs./ reel)

Specifications

Item	Symbol	Specification	Unit	Remarks
Frequency Range	f _{nom}	24, 26, 32, 37.4, 38.4, 40, 48	MHz	Please contact us for other frequency range.
Overtone Order	OT	Fundamental	—	
Load Capacitance	CL	8	pF	
Frequency Tolerance	f _{tol}	±15	×10 ⁻⁶	25°C±3°C
Motional Series Resistance	R1	Table 1	ohm	
Drive Level	DL	10μW(100μW max.)	μW	
Operating Temp. Range	T _{use}	-30 to +85	°C	
Storage Temp. Range	T _{stg}	-40 to +85	°C	
Frequency Temp. Characteristics	f _{tem}	±20	×10 ⁻⁶	Freq. deviation from the value at 25°C

Please contact us for other specifications.

Table 1 Motional Series Resistance Please contact us for other frequency range.

Frequency Range	Motional Series Resistance
24MHz	150 Ω max.
38.4MHz	80 Ω max.
48MHz	50 Ω max.

Dimensions

(Unit: mm)

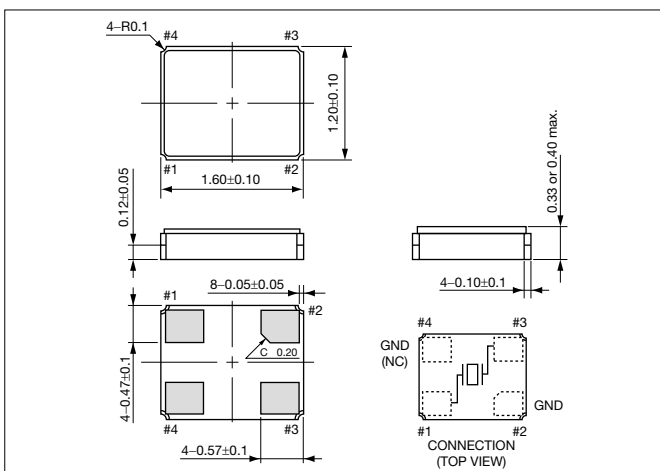

Recommended Land Pattern

(Unit: mm)

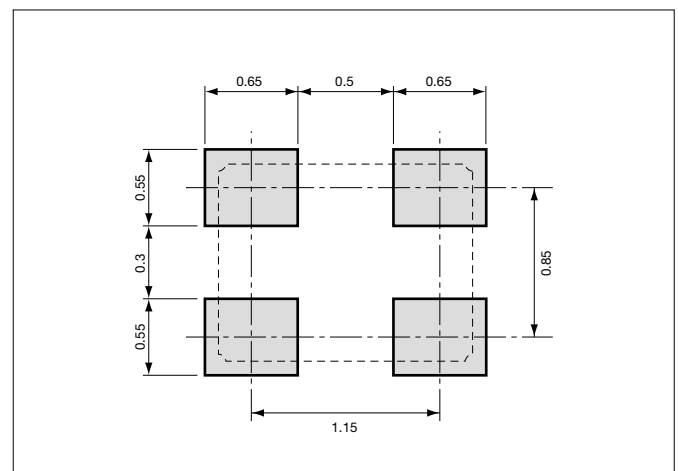



2.0×1.6mm for Consumer Products

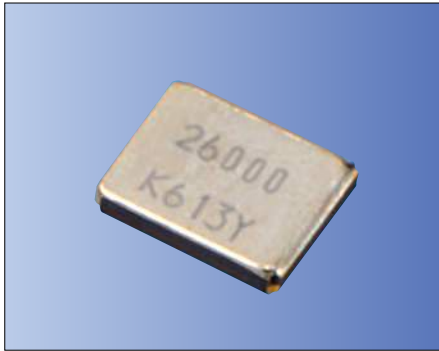

Features

- Crystal unit for Consumer Products
- Ultra-miniature and low profile (2.0×1.6×0.40mm)
- Ceramic package
- Reflow compatible

Applications

- Digital Electronics
- Consumer Products

How to Order

CX2016DB 27000 D0 G L L CC
 ① ② ③ ④ ⑤ ⑥ ⑦

- ①Series
 - ②Frequency
 - ③Load Capacitance ④Frequency Tolerance
 - D0 8 pF G ±15×10⁻⁶
 - ⑤Operating Temp. Range ⑥Frequency Temp. Stability
 - LL -30 to +85°C ±20×10⁻⁶
 - ⑦Individual Specification (STD Specification is "CC".)
- Packaging (Tape & Reel 1000/ 3000/ 15000 pcs./ reel)

Specifications

Item	Symbol	Specification	Unit	Remarks
Frequency Range	f _{nom}	16, 20, 24, 25, 26, 27, 30, 32, 37.4, 38.4, 40, 48, 50	MHz	Please contact us for other frequency range.
Overtone Order	OT	Fundamental	—	
Load Capacitance	CL	8	pF	Please contact us for other CL requirements.
Frequency Tolerance	f _{tol}	±15	×10 ⁻⁶	25°C±3°C
Motional Series Resistance	R1	Table 1	ohm	
Drive Level	DL	10μW(100μW max.)	μW	
Operating Temp. Range	T _{use}	-30 to +85	°C	
Storage Temp. Range	T _{stg}	-40 to +85	°C	
Frequency Temp. Characteristics	f _{tem}	±20	×10 ⁻⁶	Freq. deviation from the value at 25°C

Please contact us for other specifications.

Table 1 Motional Series Resistance Please contact us for other frequency range.

Frequency	Motional Series Resistance
16MHz	200 Ω max.
20MHz	150 Ω max.
32MHz	60 Ω max.
50MHz	50 Ω max.

Dimensions

(Unit: mm)

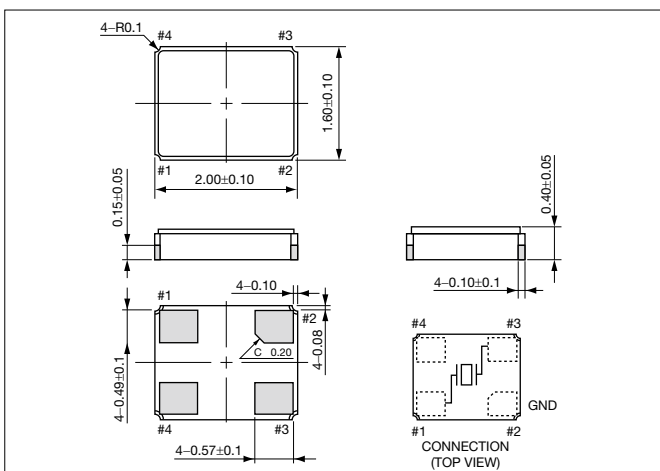

Recommended Land Pattern

(Unit: mm)

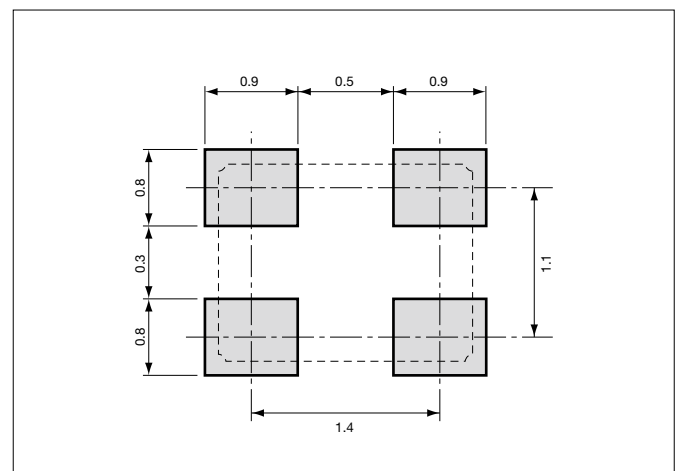



2.0×1.6mm for Consumer Products/ Automotive



AEC-Q200 RoHS Compliant

Features

- Support a wide range of applications
- Ultra-miniature and low profile (2.05×1.65×0.45mm)
- Ceramic package
- Reflow compatible

Applications

- ECU
- Automotive Camera
- Digital Electronics
- Consumer Products

How to Order

CX2016SA 20000 D0 G S S
 ① ② ③ ④ ⑤ ⑥ ⑦

①Series	②Frequency
③Load Capacitance	④Frequency Tolerance
<u>D0</u> 8 pF	<u>G</u> ±15×10 ⁻⁶

⑤Operating Temp. Range	⑥Frequency Temp. Stability
<u>SS</u> -40 to +125°C	±50×10 ⁻⁶
<u>TW</u> -40 to +150°C	±200×10 ⁻⁶
<u>LL</u> -30 to +85°C	±20×10 ⁻⁶

⑦Individual Specification

Packaging (Tape & Reel 3000/ 15000 pcs./ reel)

Specifications

Item	Symbol	Specification	Unit	Remarks
Frequency Range	f _{nom}	16, 20, 24, 25, 26, 27, 30, 32, 37.4, 38.4, 40, 48, 50	MHz	Please contact us for other frequency range.
Overtone Order	OT	Fundamental	—	
Load Capacitance	CL	8	pF	Please contact us for other CL requirements.
Frequency Tolerance	f _{tol}	±15	×10 ⁻⁶	25°C±3°C
Motional Series Resistance	R1	Table 1	ohm	
Drive Level	DL	10μW(200μW max.)	μW	
Operating Temp. Range	T _{use}	-40 to +125 -40 to +150 -30 to +85	°C	
Storage Temp. Range	T _{stg}	-40 to +150	°C	
Frequency Temp. Characteristics	f _{tem}	±50 ±200 ±20	×10 ⁻⁶	Freq. deviation from the value at 25°C

Please contact us for other specifications.

Table 1 Motional Series Resistance Please contact us for other frequency range.

Frequency Range	Motional Series Resistance
16MHz	200 Ω max.
20MHz	150 Ω max.
32MHz	60 Ω max.
50MHz	50 Ω max.

Dimensions

(Unit: mm)

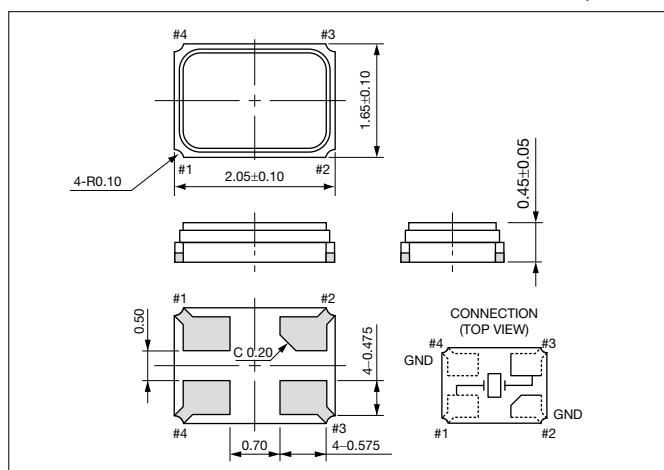

Recommended Land Pattern

(Unit: mm)

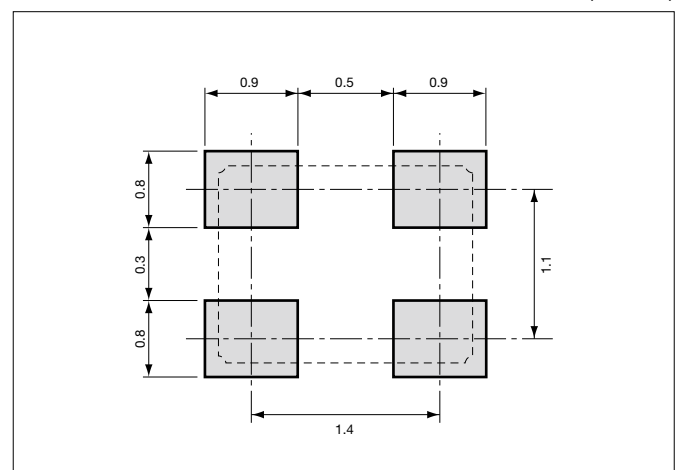



3.2×2.5mm for Automotive

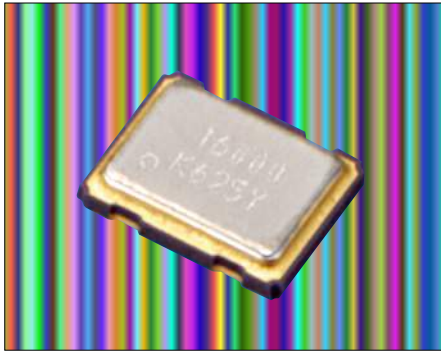

AEC-Q200 RoHS Compliant

Features

- Crystal unit for automotive electronics
- Improved solderability
- Improved mounting stability with 4 terminals
- Improved anti-noise performance with GND terminal
- Ceramic package
- Small and low profile
- Improved rust prevention performance
- Reflow compatible
- Highly reliable solder junction (3000 heat cycles -40 to +125°C)

Applications

- ECU
- TPMS
- High-Speed Automotive Network

How to Order

CX3225SA 12000 D0 G T V □□
① ② ③ ④ ⑤ ⑥ ⑦

- ①Series
 - ②Frequency
 - ③Load Capacitance
 - ④Frequency Tolerance
 - ⑤Operating Temp. Range
 - ⑥Frequency Temp. Stability
 - ⑦Individual Specification
- | | | | |
|----|---------------|---|-----------------------|
| D0 | 8 pF | G | ±15×10 ⁻⁶ |
| TV | -40 to +150°C | | ±150×10 ⁻⁶ |

Packaging (Tape & Reel 3000 pcs./ reel)

Specifications

Item	Symbol	Specification	Unit	Remarks
Frequency Range	f _{nom}	8, 10, 12, 15, 16, 20, 24, 26, 27, 40	MHz	Please contact us for other frequency range.
Overtone Order	OT	Fundamental	—	
Load Capacitance	CL	8	pF	Please contact us for other CL requirements.
Frequency Tolerance	f _{tol}	±15	×10 ⁻⁶	25°C±3°C
Motional Series Resistance	R1	Table 1	ohm	
Drive Level	DL	10μW(200μW max.)	μW	
Operating Temp. Range	T _{use}	-40 to +150	°C	
Storage Temp. Range	T _{stg}	-40 to +150	°C	
Frequency Temp. Characteristics	f _{tem}	±150	×10 ⁻⁶	Freq. deviation from the value at 25°C

Please contact us for other specifications.

Table 1 Motional Series Resistance Please contact us for other frequency range.

Frequency	Motional Series Resistance
8MHz	500 Ω max.
12MHz	200 Ω max.
16MHz	60 Ω max.
20MHz	50 Ω max.

Dimensions

(Unit: mm)

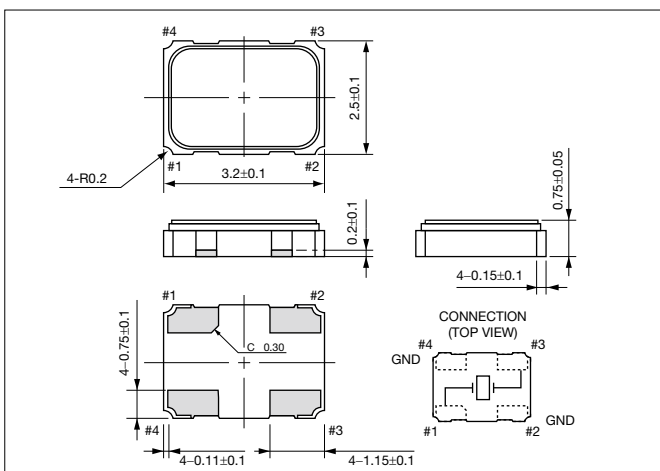

Recommended Land Pattern

(Unit: mm)

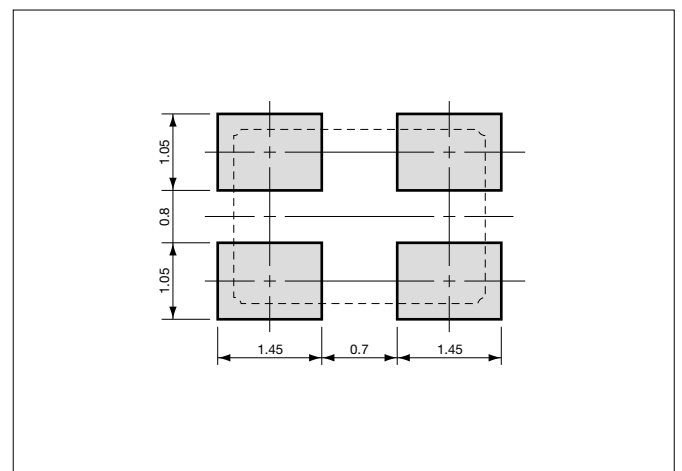



3.2×2.5mm for Automotive



Features

- Crystal unit for automotive electronics
- Improved solderability
- Small and low profile (3.2×2.5×0.85mm)
- Ceramic package
- Reflow compatible
- Acceptable heat cycle solder junction for 3000 cycles (-40 to +125°C)

Applications

- ECU
- TPMS
- High-Speed Automotive Network

How to Order

CX3225GA 16000 D0 P T V □□
 ① ② ③ ④ ⑤ ⑥ ⑦

- ①Series
- ②Frequency
- ③Load Capacitance
- ④Frequency Tolerance
- ⑤Operating Temp. Range
- ⑥Frequency Temp. Stability
- ⑦Individual Specification

D0 8 pF **P** ±50×10⁻⁶

TV -40 to +150°C ±150×10⁻⁶

Packaging (Tape & Reel 3000 pcs./ reel)



Specifications

Item	Symbol	Specification	Unit	Remarks
Frequency Range	f _{nom}	8, 12, 16, 20, 25, 40	MHz	Please contact us for other frequency range.
Overtone Order	OT	Fundamental	—	
Load Capacitance	CL	8	pF	Please contact us for other CL requirements.
Frequency Tolerance	f _{tol}	±50	×10 ⁻⁶	25°C±3°C
Motional Series Resistance	R1	Table 1	ohm	
Drive Level	DL	10μW(200μW max.)	μW	
Operating Temp. Range	T _{use}	-40 to +150	°C	
Storage Temp. Range	T _{stg}	-40 to +150	°C	
Frequency Temp. Characteristics	f _{tem}	±150	×10 ⁻⁶	Freq. deviation from the value at 25°C

Please contact us for other specifications.

Table 1 Motional Series Resistance Please contact us for other frequency range.

Frequency	Motional Series Resistance
8MHz	500 Ω max.
12MHz	200 Ω max.
20MHz	100 Ω max.

Dimensions

(Unit: mm)

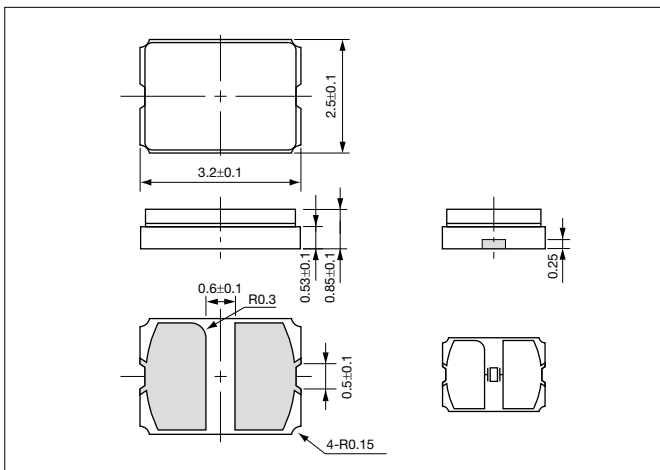

Recommended Land Pattern

(Unit: mm)

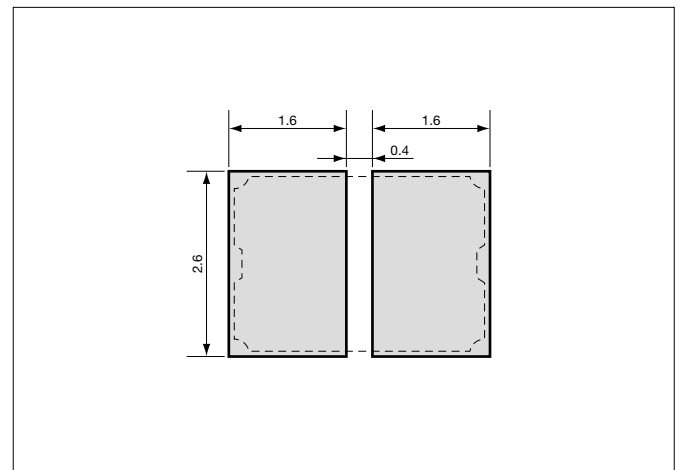



1. Shock & Drop / Vibration

Do not inflict excessive shock and mechanical vibration that exceeds the norm, such as hitting or mistakenly dropping, when transporting and mounting on a board. There are cases when pieces of crystal break, and pieces that are used become damaged, and become inoperable. When a shock or vibration that exceeds the norm has been inflicted, make sure to check the characteristics.

2. Cleaning

Since a crystal piece can be broken by resonance when a crystal device is cleaned by ultrasonic cleaning, be careful when carrying out ultrasonic cleaning.

3. Soldering conditions

To maintain the product reliability, please follow recommended conditions.

Standard soldering iron conditions

	Crystal Units
Soldering iron	280°C to 340°C
Time	3+1/ -0 sec. max.

Reflow conditions (Example)

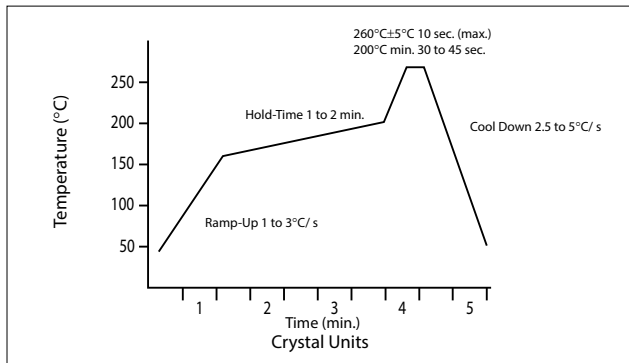

Recommended reflow Conditions vary depending upon products. Please check with the respective specification for details.

4. Mounting Precautions

The lead of the device and the pattern of the board is soldered on the surface. Since extreme deformation of the board tears off the pattern, tears off the lead metal, cracks the solder and damages the sealed part of the device and there are cases in which performance deteriorates and operation fails, use it within the stipulated bending conditions. Due to the small cracks in the board resulting from mounting, please pay sufficient attention when attaching a device at the position where the warping of the board is great.

When using an automatic loading machine, as far as possible, select a type that has a small impact and use it while confirming that there is no damage.

Surface mount devices are NOT flow soldering compatible.

5. Storage Condition

Since the long hour high temperature and low temperature storage, as well as the storage at high humidity are causes of deterioration in frequency accuracy and solderability.

Parts should be stored in temperature range of -5 to +40°C, humidity 40 to 60% RH, and avoid direct sunlight. Then use within 6 months.

Tape & Reel Specifications

Crystal Units

(Unit: mm)

	CT1612RB	CT2016DB	CX1008SB	CX1210DB CX1210SB	CX1612DB	CX2016DB CX2016SA	CX2520DB			
T A P E	A	2.0±0.05	2.0±0.05	2.0±0.05	2.0±0.05	2.0±0.05	2.0±0.05			
	B	4.0±0.1	4.0±0.1	4.0±0.1	4.0±0.1	4.0±0.1	4.0±0.1			
	C	φ1.5+0.1/-0	φ1.5+0.1/-0	φ1.5+0.1/-0	φ1.5+0.1/-0	φ1.5+0.1/-0	φ1.5+0.1/-0			
	D	4.0±0.1	4.0±0.1	4.0±0.1	4.0±0.1	4.0±0.1	4.0±0.1			
	E	3.5±0.05	3.5±0.05	3.5±0.05	3.5±0.05	3.5±0.05	3.5±0.05			
	F	1.75±0.1	1.75±0.1	1.75±0.1	1.75±0.1	1.75±0.1	1.75±0.1			
	G	8.0±0.2	8.0±0.2	8.0±0.2	8.0±0.2	8.0±0.2	8.0±0.2			
	H	φ0.5+0.05	φ1.0+0.1/-0	φ0.5±0.1	φ0.5+0.05	φ0.5±0.05	φ1.05±0.05	φ1.05±0.05		
	J	1.90±0.1	2.3±0.05/ 2.2±0.05	1.20±0.05	1.55±0.05	1.80±0.1	2.30±0.1	2.7±0.1		
	L	1.50±0.1	1.9±0.05	1.00±0.05	1.35±0.05	1.40±0.1	1.90±0.1	2.2±0.1		
	N	0.75±0.05	1.1±0.05/ 0.75±0.05	0.45±0.05	0.45±0.05	0.5±0.1	0.7±0.05	0.6±0.1		
	O	0.2±0.05	0.25±0.05	0.2±0.05	0.25±0.05	0.2±0.05	0.2±0.05	0.2±0.05		
	R E E L	P	φ330±2	φ330±0.2	φ330±2	φ330±2	φ180+0/-3	φ330±2	φ180+0/-3	φ330±2
Q		φ100±1.0	φ100±1.0	φ100±1.0	φ100±1.0	φ60+1/-0	φ100±1.0	φ60+1/-0	φ100±1.0	
R		φ13±0.2	φ13±0.2	φ13±0.2	φ13±0.2	φ13±0.2	φ13±0.2	φ13±0.2	φ13±0.2	
S		φ21±0.8	φ21±0.8	φ21±0.8	φ21±0.8	φ21±0.8	φ21±0.8	φ21±0.8	φ21±0.8	
U		2.0±0.5	2.0±0.5	2.0±0.5	2.0±0.5	2.0±0.5	2.0±0.5	2.0±0.5	2.0±0.5	
W		9.4±1.0	9.4±1.0	9.4±1.0	9.4±1.0	9.0±1.0	9.4±1.0	9.0±1.0	9.4±1.0	
Qty.		15000	12000	21000	12000/21000	3000	20000	3000	15000	3000

	CX3225SA CX3225GA	
T A P E	A	2.0±0.05
	B	4.0±0.1
	C	φ1.55±0.05
	D	4.0±0.05
	E	3.5±0.05
	F	1.75±0.1
	G	8.0±0.2
	H	φ1.05±0.1
	J	3.5±0.1
	L	2.8±0.1
	N	1.0±0.1
	O	0.25±0.05
	R E E L	P
E		φ60+1/-0
E		φ13±0.2
L		φ21±0.8
U		2.0±0.5
W	9.0±1.0	
Qty.	3000	

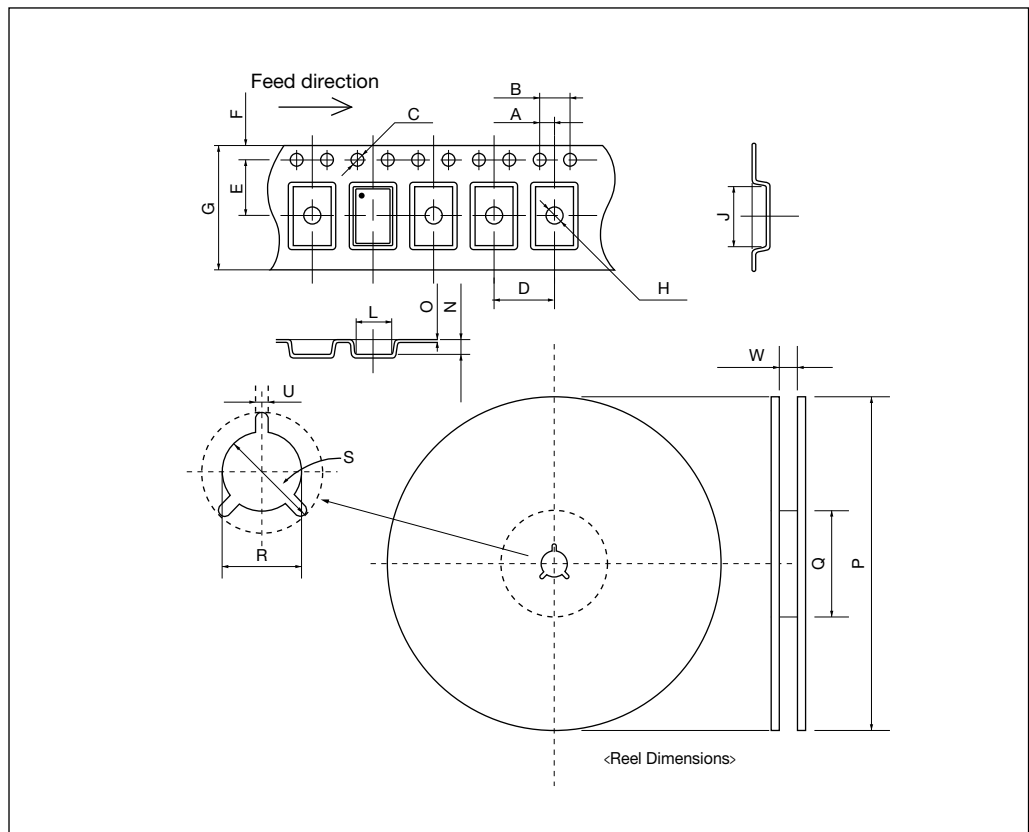

Packaging Specifications



CMOS/ 1.8V, 2.5V, 3.3V/ 2.0×1.6, 2.5×2.0, 3.2×2.5, 5.0×3.2, 7.0×5.0mm

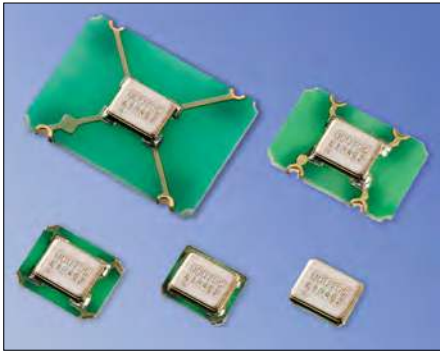

RoHS Compliant

Dimensions

(Unit : mm)

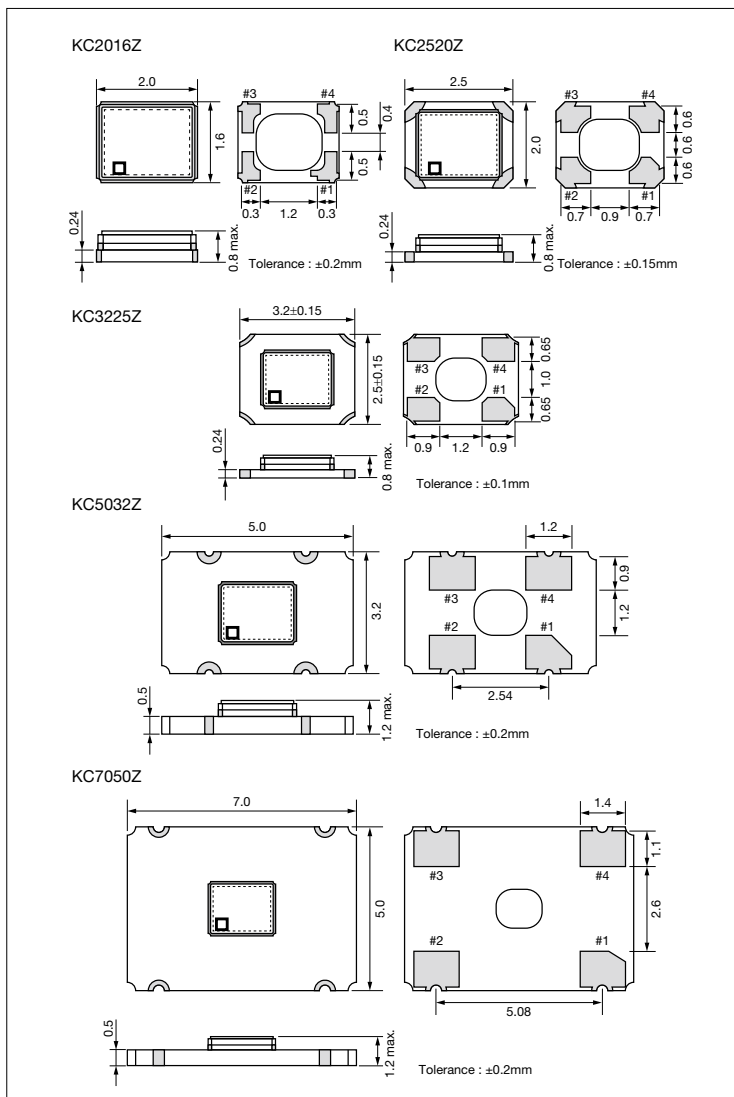

Recommended Land Patterns

(Unit : mm)

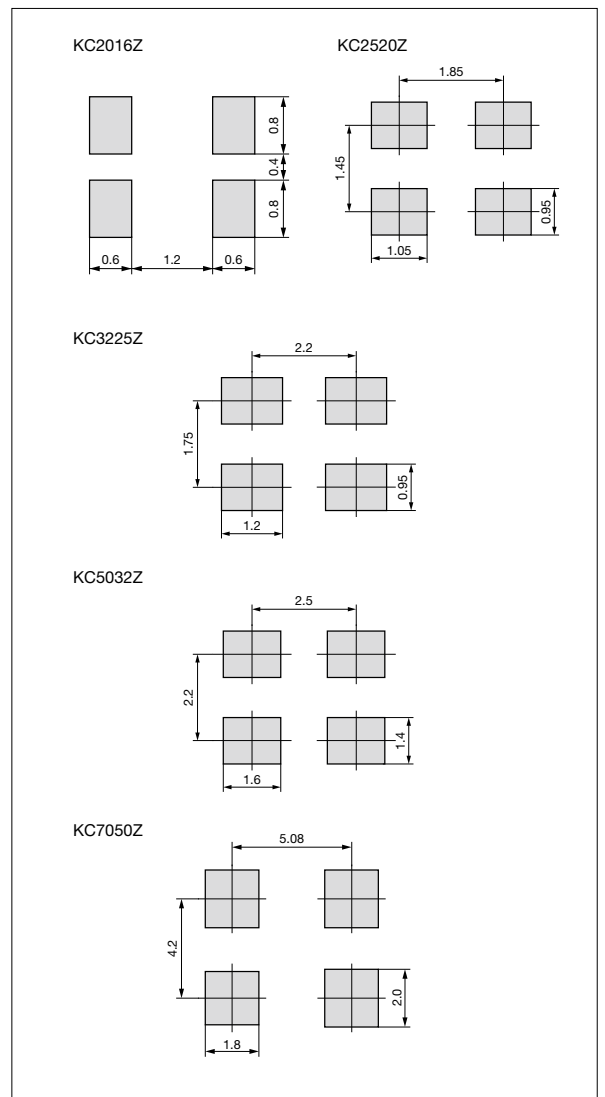

Clock Oscillators

Pad Connections	
#1	Stand-by Function
#2	Case GND
#3	Output
#4	Vcc

Stand-by Function	
Pad1	Pad3 (Output)
Open	Active
"H" Level	Active
"L" Level	High Z (No-Oscillation)



CMOS/ 1.8V, 2.5V, 3.3V / 2.0×1.6, 2.5×2.0, 3.2×2.5, 5.0×3.2, 7.0×5.0mm

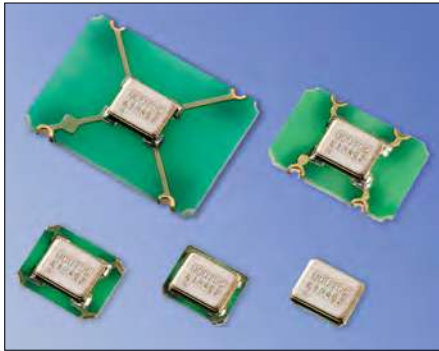

RoHS Compliant

Features

- Frequency Range 0.5 to 170 MHz
- CMOS Output
- Short Lead Time
- Heat resistant up to +125°C

Applications

- Consumer/ Networking/ Industrial/ Amuse

Table 1

Freq. Tol. Code	× 10 ⁻⁶	Operating Temperature Range (°C)	Note
S	± 30	-10 to +70	For additional stability, please contact us.
U	± 25		
W	± 20		
G	± 50	-40 to +85	
H	± 30		
J	± 25		
K	± 20	-40 to +105	
L	± 15		
6	± 50		
5	± 30	-40 to +125	
X	± 100		
Z	± 50		
9	± 30		

How to Order

KC□□□□Z 25.0000 C 1 □ X 00
① ② ③ ④ ⑤ ⑥ ⑦

①Series

KC2016Z	2016 Size	KC2520Z	2520 Size
KC3225Z	3225 Size	KC5032Z	5032 Size
KC7050Z	7050 Size		

②Output Frequency (25.0000 : 25MHz)

③Output Type (C : CMOS)

④Supply Voltage

(1 : 1.8V/ 2.5V/ 3.3V Compatible)

⑤Frequency Tolerance (See Table 1)

⑥Symmetry/ INH Function

X	STD 45/ 55%
---	-------------

⑦Individual Specification

(STD Specification is "00")

Packaging Tape&Reel

KC7050Z/ KC5032Z	1000 pcs./ reel
KC3225Z/ KC2520Z/ KC2016Z	2000 pcs./ reel

Specifications

Item	Symbol	Conditions	Min.	Max.	Unit	
Output Frequency Range	f _o		0.5	170	MHz	
Frequency Tolerance	f _{tol}	Initial tolerance, Operating temperature range, Rated power supply voltage change, Load change, Aging (1 year @25°C), Shock and vibration	See Table 1.			
Storage Temperature Range	T _{stg}		-55	150	°C	
Operating Temperature Range	T _{use}		See Table 1.			
Max. Supply Voltage	—		-0.3	4.5	V	
Supply Voltage	V _{cc}		1.71	3.63	V	
Current Consumption (Noload/ 1.71≤V _{cc} ≤2.25)	I _{cc}	0.5≤f _o <5MHz	—	5.2	mA	
		5≤f _o <15MHz	—	5.8		
		15≤f _o <30MHz	—	6.2		
		30≤f _o <50MHz	—	6.8		
		50≤f _o ≤60MHz	—	6.8		
		60<f _o <75MHz	—	9		
		75≤f _o <105MHz	—	10		
		105≤f _o <130MHz	—	10.5		
		130≤f _o <160MHz	—	11.5		
160≤f _o ≤170MHz	—	12.5				
Current Consumption (Noload/ 2.25<V _{cc} ≤2.8)	I _{cc}	0.5≤f _o <5MHz	—	5.5	mA	
		5≤f _o <15MHz	—	6		
		15≤f _o <30MHz	—	6.5		
		30≤f _o <50MHz	—	7.2		
		50≤f _o ≤60MHz	—	7.4		
		60<f _o <75MHz	—	10		
		75≤f _o <105MHz	—	11.5		
		105≤f _o <130MHz	—	12.5		
		130≤f _o <160MHz	—	14		
160≤f _o ≤170MHz	—	15				
Current Consumption (Noload/ 2.8<V _{cc} ≤3.63)	I _{cc}	0.5≤f _o <5MHz	—	5.8	mA	
		5≤f _o <15MHz	—	6.5		
		15≤f _o <30MHz	—	7.3		
		30≤f _o <50MHz	—	8		
		50≤f _o ≤60MHz	—	8.5		
		60<f _o <75MHz	—	12.5		
		75≤f _o <105MHz	—	14.5		
		105≤f _o <130MHz	—	15.5		
		130≤f _o <160MHz	—	18		
160≤f _o ≤170MHz	—	19.5				
Stand-by Current	I _{std}		—	5	μA	
Symmetry	SYM	@50% V _{cc}	45	55	%	
Rise/ Fall Time (20% to 80% Output Level)	Tr/ Tf	0.5≤f _o ≤60MHz	Loaded/ 1.71≤V _{cc} ≤2.25	—	4	ns
			Loaded/ 2.25<V _{cc} ≤2.8	—	3	
			Loaded/ 2.8<V _{cc} ≤3.63	—	2.5	
		60<f _o ≤170MHz	Loaded/ 1.71≤V _{cc} ≤2.25	—	1.5	
			Loaded/ 2.25<V _{cc} ≤2.8	—	1.3	
			Loaded/ 2.8<V _{cc} ≤3.63	—	1	
Low Level Output Voltage	V _{OL}	I _{OL} = 4mA	—	10% V _{cc}	V	
High Level Output Voltage	V _{OH}	I _{OH} = -4mA	90% V _{cc}	—	V	
Output Load (CMOS)	L _{CMOS}		—	15	pF	
Low Level Input Voltage	V _{IL}		—	30% V _{cc}	V	
High Level Input Voltage	V _{IH}		70% V _{cc}	—	V	
Disable Time	t _{dis}		—	200	ns	
Enable Time	t _{ena}		—	5	ms	
Start-up Time	t _{str}	@Minimum operating voltage to be 0 sec.	—	5	ms	

All electrical characteristics are defined at the maximum load and operating temperature range.



CMOS/ 1.8V, 2.5V, 3.3V / 2.0×1.6, 2.5×2.0, 3.2×2.5, 5.0×3.2, 7.0×5.0mm

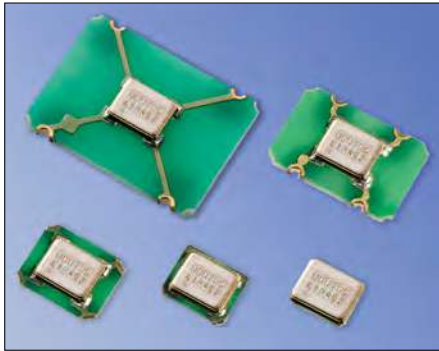

RoHS Compliant

Features

- Frequency Range 24 to 72 MHz
- CMOS Output
- Low Jitter
- Heat resistant up to +125°C

Applications

- Consumer/ Networking/ Industrial/ Amuse

Table 3

Freq. Code	Tol. $\times 10^{-6}$	Operating Temperature Range (°C)	Note
S	± 30	-10 to +70	For additional stability, please contact us.
U	± 25		
W	± 20		
G	± 50		
H	± 30	-40 to +85	
J	± 25		
K	± 20		
L	± 15		
6	± 50	-40 to +105	
5	± 30		
X	± 100		
Z	± 50	-40 to +125	
9	± 30		

How to Order

KC□□□□Z 25.0000 C 1 □ Y 00
① ② ③ ④ ⑤ ⑥ ⑦

①Series

KC2016Z	2016 Size	KC2520Z	2520 Size
KC3225Z	3225 Size	KC5032Z	5032 Size
KC7050Z	7050 Size		

②Output Frequency (25.0000 : 25MHz)

③Output Type (C : CMOS)

④Supply Voltage

(1 : 1.8V/ 2.5V/ 3.3V Compatible)

⑤Frequency Tolerance (See Table 3)

⑥Symmetry/ INH Function

Y	STD/ Low Jitter 45/ 55%
---	-------------------------

⑦Individual Specification

(STD Specification is "00")

Packaging Tape&Reel

KC7050Z/ KC5032Z	1000 pcs./ reel
KC3225Z/ KC2520Z/ KC2016Z	2000 pcs./ reel

Specifications

Item	Symbol	Conditions	Min.	Max.	Unit	
Output Frequency Range	fo		24	72	MHz	
Frequency Tolerance	f _{tol}	Initial tolerance, Operating temperature range, Rated power supply voltage change, Load change, Aging (1 year @25°C), Shock and vibration	See Table 3			
Storage Temperature Range	T _{stg}		-55	150	°C	
Operating Temperature Range	T _{use}		See Table 3			
Max. Supply Voltage	—		-0.3	4.5	V	
Supply Voltage	V _{cc}		1.71	3.63	V	
Current Consumption (Noload/ 1.71≤V _{cc} ≤2.25)	I _{cc}	24≤fo<30MHz	—	2.7	mA	
		30≤fo<50MHz	—	3.3		
		50≤fo≤60MHz	—	3.7		
		60<fo<72MHz	—	4		
Current Consumption (Noload/ 2.25<V _{cc} ≤2.8)	I _{cc}	24≤fo<30MHz	—	3.5		
		30≤fo<50MHz	—	4		
		50≤fo≤60MHz	—	4.3		
		60<fo<72MHz	—	4.8		
Current Consumption (Noload/ 2.8<V _{cc} ≤3.63)	I _{cc}	24≤fo<30MHz	—	4		
		30≤fo<50MHz	—	5		
		50≤fo≤60MHz	—	5.5		
		60<fo<72MHz	—	6		
Stand-by Current	I _{std}		—	5	μA	
Symmetry	SYM	@50% V _{cc}	24≤fo≤40MHz	40	55	%
			40<fo≤72MHz	45	55	
Rise/ Fall Time (20% to 80% Output Level)	Tr/ Tf	Loaded/ 1.71≤V _{cc} ≤2.25	—	4	ns	
		Loaded/ 2.25<V _{cc} ≤2.8	—	3.2		
		Loaded/ 2.8<V _{cc} ≤3.63	—	2.7		
Low Level Output Voltage	V _{OL}	I _{OL} = 4mA	—	10% V _{cc}	V	
High Level Output Voltage	V _{OH}	I _{OH} = -4mA	90% V _{cc}	—	V	
Output Load (CMOS)	L _{CMOS}		—	15	pF	
Low Level Input Voltage	V _{IL}		—	30% V _{cc}	V	
High Level Input Voltage	V _{IH}		70% V _{cc}	—	V	
Disable Time	t _{dis}		—	200	ns	
Enable Time	t _{ena}		—	10	ms	
Start-up Time	t _{str}	@Minimum operating voltage to be 0 sec.	—	10	ms	
1 Sigma Jitter	J _{Sigma}	Measured with Wavecrest SIA-3000	—	5	ps	
Peak to Peak Jitter	J _{PK_PK}		—	50		
Phase Jitter	—	@50MHz V _{cc} = 3.3V	BW : 12kHz to 20MHz		1	ps

All electrical characteristics are defined at the maximum load and operating temperature range.



CMOS/ 1.8V, 2.5V, 3.3V / 2.0×1.6, 2.5×2.0, 3.2×2.5, 5.0×3.2, 7.0×5.0mm for Automotive

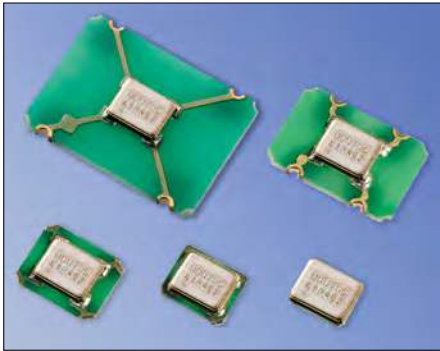

AEC-Q100/200 RoHS Compliant

Dimensions

(Unit : mm)

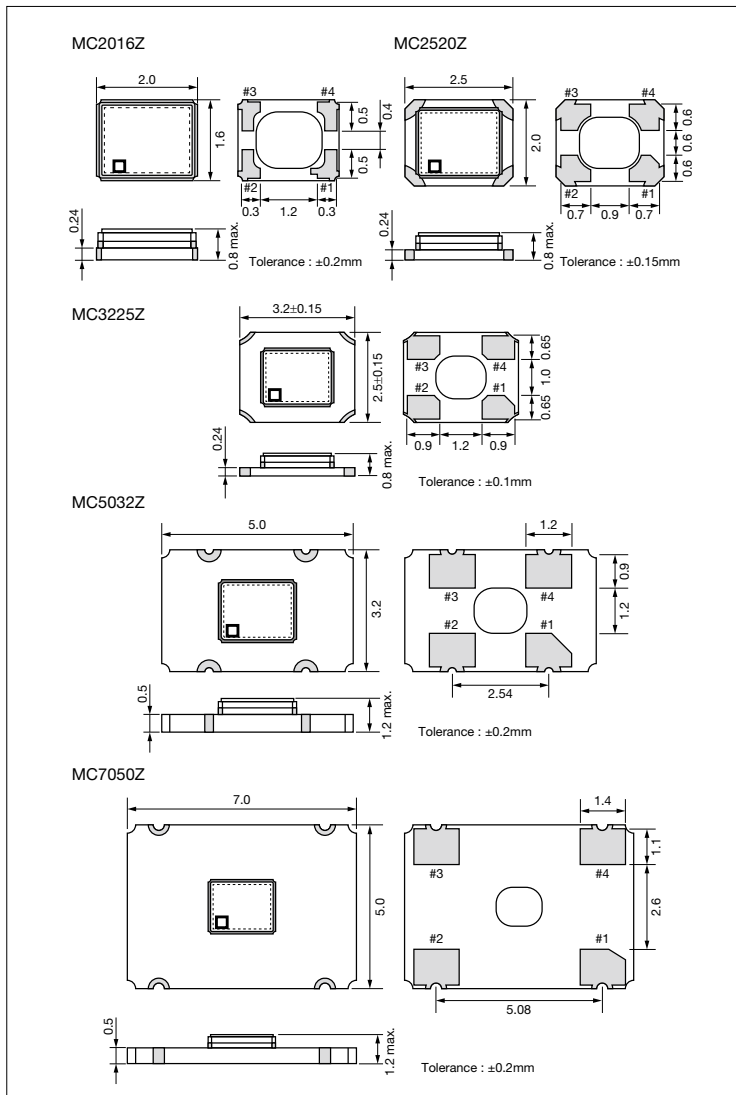

Recommended Land Pattern

(Unit : mm)

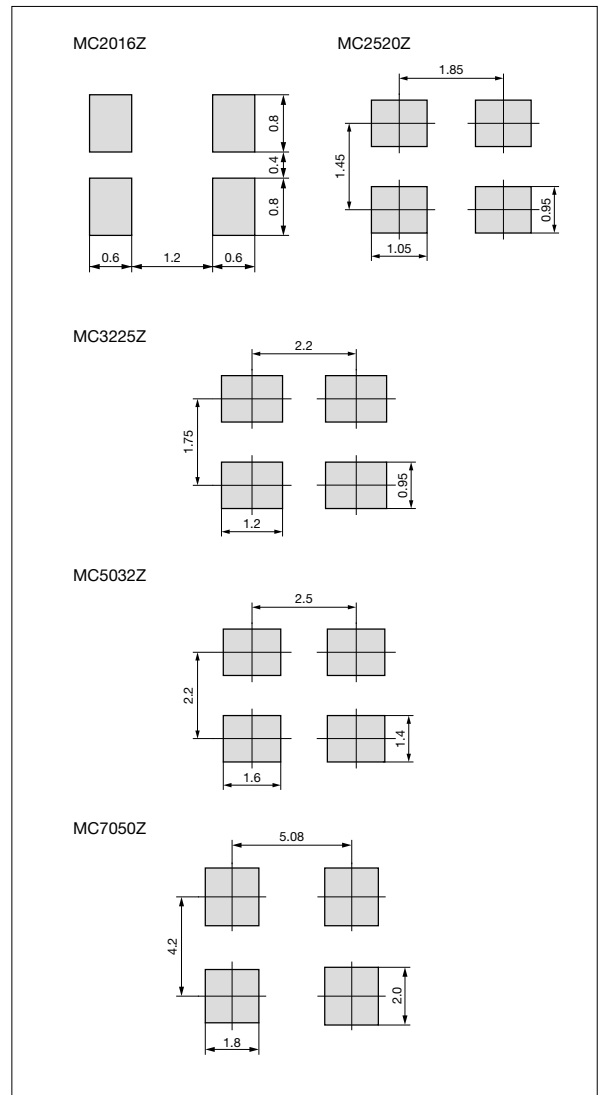

Clock Oscillators

Pad Connections	
#1	Stand-by Function
#2	Case GND
#3	Output
#4	Vcc

Stand-by Function	
Pad1	Pad3 (Output)
Open	Active
"H" Level	Active
"L" Level	High Z (No-Oscillation)

Clock Oscillators Surface Mount Type Clock MC-Z-Series "X" type (STD, Short LT type)



CMOS/ 1.8V, 2.5V, 3.3V / 2.0×1.6, 2.5×2.0, 3.2×2.5, 5.0×3.2, 7.0×5.0mm for Automotive

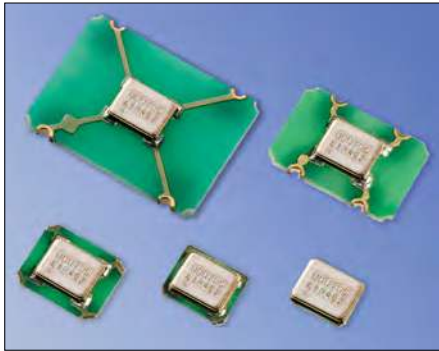

AEC-Q100/200 RoHS Compliant

Features

- Frequency Range 0.5 to 170 MHz
- CMOS Output
- Short Lead Time
- Heat resistant up to +125°C

Applications

- Automotive

Table 5

Freq. Code	Tol. $\times 10^{-6}$	Operating Temperature Range (°C)	Note
G	± 50	-40 to +85	For additional stability, please contact us.
H	± 30		
J	± 25		
K	± 20	-40 to +105	
6	± 50		
5	± 30	-40 to +125	
X	± 100		
Z	± 50		
9	± 30		

How to Order

MC□□□□Z 25.0000 C 1 □ X SH
① ② ③ ④ ⑤ ⑥ ⑦

①Series

MC2016Z	2016 Size	MC2520Z	2520 Size
MC3225Z	3225 Size	MC5032Z	5032 Size
MC7050Z	7050 Size		

②Output Frequency (25.0000 : 25MHz)

③Output Type (C : CMOS)

④Supply Voltage

(1 : 1.8V/ 2.5V/ 3.3V Compatible)

⑤Frequency Tolerance (See Table 5)

⑥Symmetry/ INH Function

X	STD 45/ 55%
---	-------------

⑦Individual Specification

(STD Specification is "SH".)

Packaging Tape&Reel

MC7050Z/ MC5032Z	1000 pcs./ reel
MC3225Z/ MC2520Z/ MC2016Z	2000 pcs./ reel

Specifications

Item	Symbol	Conditions	Min.	Max.	Unit	
Output Frequency Range	fo		0.5	170	MHz	
Frequency Tolerance	f _{tol}	Initial tolerance, Operating temperature range, Rated power supply voltage change, Load change, Aging (1 year @25°C), Shock and vibration	See Table 5			
Storage Temperature Range	T _{stg}		-55	150	°C	
Operating Temperature Range	T _{use}		See Table 5			
Max. Supply Voltage	—		-0.3	4.5	V	
Supply Voltage	V _{cc}		1.71	3.63	V	
Current Consumption (Noload/ 1.71<V _{cc} <2.25)	I _{cc}	0.5≤fo<5MHz	—	5.2	mA	
		5≤fo<15MHz	—	5.8		
		15≤fo<30MHz	—	6.2		
		30≤fo<50MHz	—	6.8		
		50≤fo<60MHz	—	6.8		
		60<fo<75MHz	—	9		
		75≤fo<105MHz	—	10		
		105≤fo<130MHz	—	10.5		
		130≤fo<160MHz	—	11.5		
160≤fo≤170MHz	—	12.5				
Current Consumption (Noload/ 2.25<V _{cc} <2.8)	I _{cc}	0.5≤fo<5MHz	—	5.5	mA	
		5≤fo<15MHz	—	6		
		15≤fo<30MHz	—	6.5		
		30≤fo<50MHz	—	7.2		
		50≤fo<60MHz	—	7.4		
		60<fo<75MHz	—	10		
		75≤fo<105MHz	—	11.5		
		105≤fo<130MHz	—	12.5		
		130≤fo<160MHz	—	14		
160≤fo≤170MHz	—	15				
Current Consumption (Noload/ 2.8<V _{cc} <3.63)	I _{cc}	0.5≤fo<5MHz	—	5.8	mA	
		5≤fo<15MHz	—	6.5		
		15≤fo<30MHz	—	7.3		
		30≤fo<50MHz	—	8		
		50≤fo<60MHz	—	8.5		
		60<fo<75MHz	—	12.5		
		75≤fo<105MHz	—	14.5		
		105≤fo<130MHz	—	15.5		
		130≤fo<160MHz	—	18		
160≤fo≤170MHz	—	19.5				
Stand-by Current	I _{std}		—	5	μA	
Symmetry	SYM	@50% V _{cc}	45	55	%	
Rise/ Fall Time (20% to 80% Output Level)	Tr/ Tf	0.5≤fo≤60MHz	Loaded/ 1.71≤V _{cc} ≤2.25	—	4	ns
			Loaded/ 2.25<V _{cc} ≤2.8	—	3	
			Loaded/ 2.8<V _{cc} ≤3.63	—	2.5	
		60<fo≤170MHz	Loaded/ 1.71≤V _{cc} ≤2.25	—	1.5	
			Loaded/ 2.25<V _{cc} ≤2.8	—	1.3	
			Loaded/ 2.8<V _{cc} ≤3.63	—	1	
Low Level Output Voltage	V _{OL}	I _{OL} = 4mA	—	10% V _{cc}	V	
High Level Output Voltage	V _{OH}	I _{OH} = -4mA	90% V _{cc}	—	V	
Output Load (CMOS)	L		—	15	pF	
Low Level Input Voltage	V _{IL}		—	30% V _{cc}	V	
High Level Input Voltage	V _{IH}		70% V _{cc}	—	V	
Disable Time	t _{dis}		—	200	ns	
Enable Time	t _{ena}		—	5	ms	
Start-up Time	t _{str}	@Minimum operating voltage to be 0 sec.	—	5	ms	

All electrical characteristics are defined at the maximum load and operating temperature range.

Clock Oscillators Surface Mount Type

Clock MC-Z-Series "Y" type (CMOS, Low Jitter type)



CMOS/ 1.8V, 2.5V, 3.3V / 2.0×1.6, 2.5×2.0, 3.2×2.5, 5.0×3.2, 7.0×5.0mm for Automotive

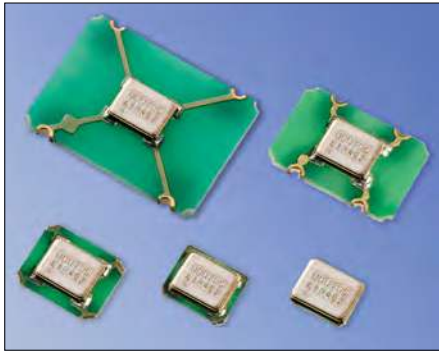

AEC-Q100/200 RoHS Compliant

Features

- Frequency Range 24 to 72 MHz
- CMOS Output
- Low Jitter
- Heat resistant up to +125°C

Applications

- Automotive (Radar, Camera, Network)

Table 7

Freq. Code	Tol. $\times 10^{-6}$	Operating Temperature Range (°C)	Note
G	± 50	-40 to +85	For additional stability, please contact us.
H	± 30		
J	± 25		
K	± 20		
6	± 50	-40 to +105	
5	± 30		
X	± 100	-40 to +125	
Z	± 50		
9	± 30		

How to Order

MC□□□□Z 25.0000 C 1 □ Y SH
① ② ③ ④ ⑤ ⑥ ⑦

①Series

MC2016Z	2016 Size	MC2520Z	2520 Size
MC3225Z	3225 Size	MC5032Z	5032 Size
MC7050Z	7050 Size		

②Output Frequency (25.0000 : 25MHz)

③Output Type (C : CMOS)

④Supply Voltage

(1 : 1.8V/ 2.5V/ 3.3V Compatible)

⑤Frequency Tolerance (See Table 7)

⑥Symmetry/ INH Function

Y	STD/ Low Jitter 45/ 55%
---	-------------------------

⑦Individual Specification

(STD Specification is "SH".)

Packaging Tape&Reel

MC7050Z/ MC5032Z	1000 pcs./ reel
MC3225Z/ MC2520Z/ MC2016Z	2000 pcs./ reel

Specifications

Item	Symbol	Conditions	Min.	Max.	Unit	
Output Frequency Range	fo		24	72	MHz	
Frequency Tolerance	f _{tol}	Initial tolerance, Operating temperature range, Rated power supply voltage change, Load change, Aging (1 year @25°C), Shock and vibration	See Table 7			
Storage Temperature Range	T _{stg}		-55	150	°C	
Operating Temperature Range	T _{use}		See Table 7			
Max. Supply Voltage	—		-0.3	4.5	V	
Supply Voltage	V _{CC}		1.71	3.63	V	
Current Consumption (Noload/ 1.71≤V _{CC} ≤2.25)	I _{CC}	24≤fo<30MHz	—	2.7	mA	
		30≤fo<50MHz	—	3.3		
		50≤fo≤60MHz	—	3.7		
		60<fo<72MHz	—	4		
Current Consumption (Noload/ 2.25<V _{CC} ≤2.8)	I _{CC}	24≤fo<30MHz	—	3.5		
		30≤fo<50MHz	—	4		
		50≤fo≤60MHz	—	4.3		
		60<fo<72MHz	—	4.8		
Current Consumption (Noload/ 2.8<V _{CC} ≤3.63)	I _{CC}	24≤fo<30MHz	—	4		
		30≤fo<50MHz	—	5		
		50≤fo≤60MHz	—	5.5		
		60<fo<72MHz	—	6		
Stand-by Current	I _{std}		—	5	μA	
Symmetry	SYM	@50% V _{CC}	24≤fo≤40MHz	40	55	%
			40<fo≤72MHz	45	55	
Rise/ Fall Time (20% to 80% Output Level)	Tr/ Tf	Loaded/ 1.71≤V _{CC} ≤2.25	—	4	ns	
		Loaded/ 2.25<V _{CC} ≤2.8	—	3.2		
		Loaded/ 2.8<V _{CC} ≤3.63	—	2.7		
Low Level Output Voltage	V _{OL}	I _{OL} = 4mA	—	10% V _{CC}	V	
High Level Output Voltage	V _{OH}	I _{OH} = -4mA	90% V _{CC}	—	V	
Output Load (CMOS)	L _{CMOS}		—	15	pF	
Low Level Input Voltage	V _{IL}		—	30% V _{CC}	V	
High Level Input Voltage	V _{IH}		70% V _{CC}	—	V	
Disable Time	t _{dis}		—	200	ns	
Enable Time	t _{ena}		—	10	ms	
Start-up Time	t _{str}	@Minimum operating voltage to be 0 sec.	—	10	ms	
1 Sigma Jitter	J _{Sigma}	Measured with Wavecrest SIA-3000	—	5	ps	
Peak to Peak Jitter	J _{PK_PK}		—	50		
Phase Jitter	—	@50MHz V _{CC} = 3.3V	BW : 12kHz to 20MHz		1	ps

All electrical characteristics are defined at the maximum load and operating temperature range.



CMOS/ 1.8V, 2.5V, 3.3V / 2.0×1.6, 2.5×2.0, 3.2×2.5, 5.0×3.2, 7.0×5.0mm

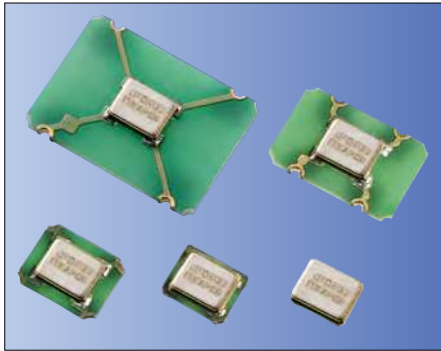

RoHS Compliant

Features

- Frequency Range 1.5 to 160MHz
- CMOS output
- Wide Supply Voltage
 - 1.6 to 3.63V
- Low current consumption
- Low Phase Noise

Applications

- Consumer/ Networking/ Industrial/ Audio Codec/ Amuse

How to Order

KC2520K 25.0000 C □ □ E 00
 ① ② ③ ④ ⑤ ⑥ ⑦

- ①Series
- ②Output Frequency (25.0000: 25MHz)
- ③Output Type (C: CMOS)
- ④Supply Voltage

1	1.8V/ 2.5V/ 3.3V compatible
2	2.5V/ 3.3V compatible

- ⑤Frequency Tolerance (See Table 1)
- ⑥Symmetry/ INH Function

E	45/ 55%
---	---------

- ⑦Individual Specification (STD Specification is "00".)

Packaging Tape & Reel

KC7050K/ KC5032K	1000 pcs./ reel
KC3225K/ KC2520K/ KC2016K	2000 pcs./ reel

Table 1

Freq. Code	Tol. × 10 ⁻⁶	Operating Temperature Range (°C)	Note
0	± 50	-10 to +70	Standard specifications With only certain frequencies
S	± 30	-10 to +70	
U	± 25	-10 to +70	
G	± 50	-40 to +85	
6	± 50	-40 to +105	

Dimensions

(Unit: mm)

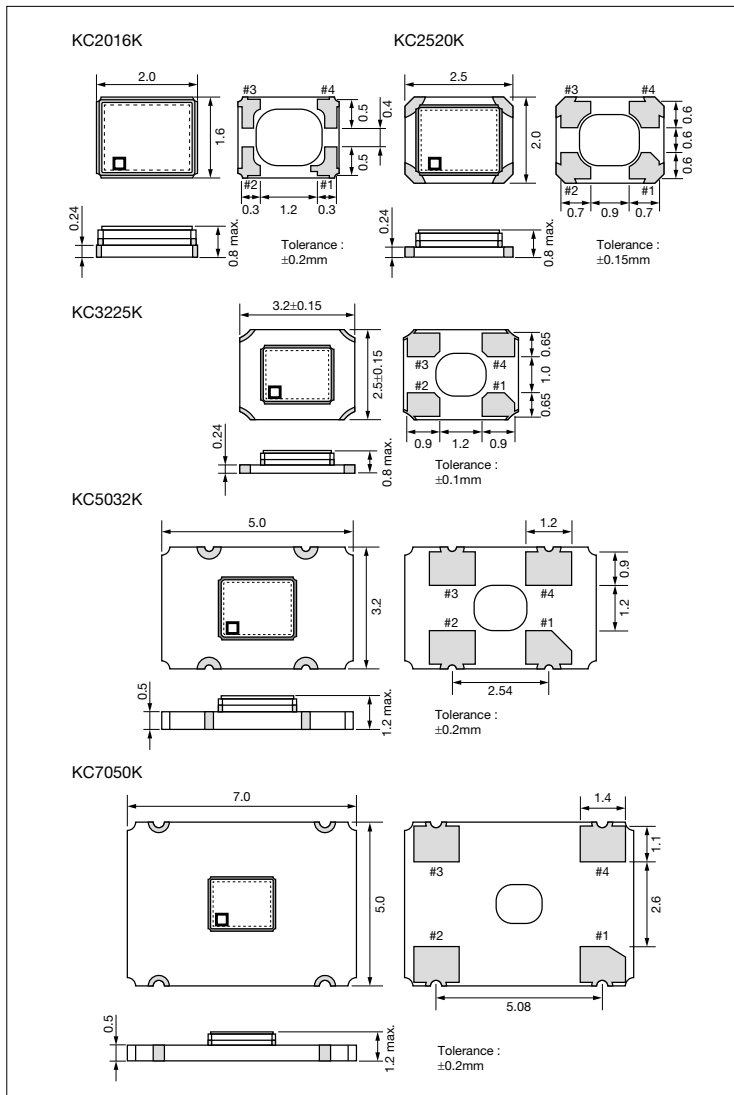

Recommended Land Pattern

(Unit: mm)

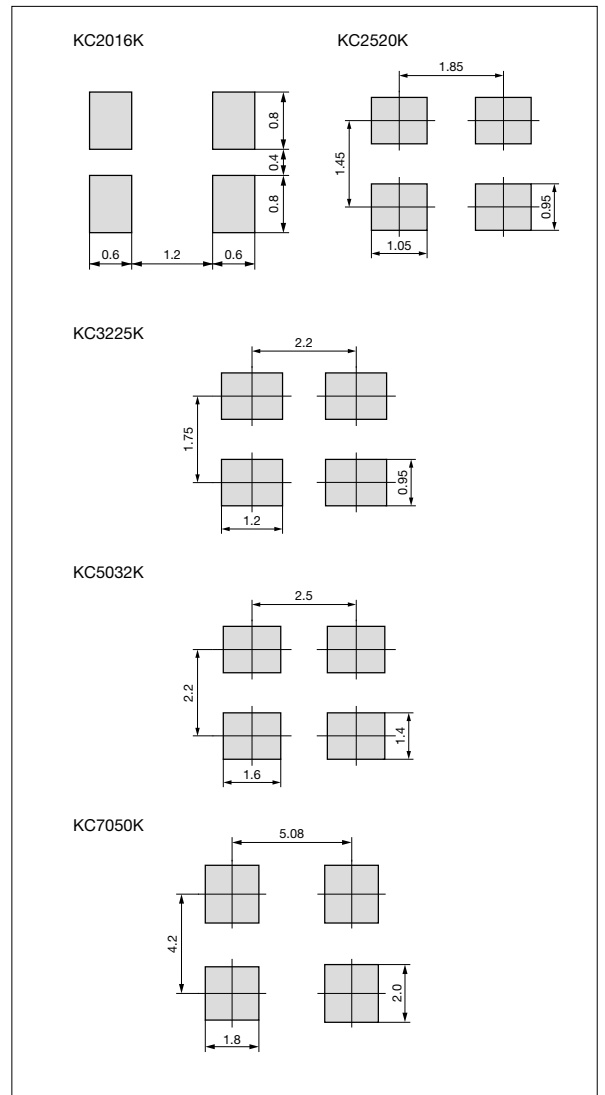



CMOS/ 1.8V, 2.5V, 3.3V / 2.0×1.6, 2.5×2.0, 3.2×2.5, 5.0×3.2, 7.0×5.0mm

Specifications

Item	Symbol	Conditions	Min.	Max.	Unit	
Output Frequency Range ^{Note1}	f _o		1.5	160	MHz	
Frequency Tolerance	f _{tol}	Initial tolerance, Operating temperature range, Rated power supply voltage change, Load change, Aging (1 year @25°C), Shock and vibration	Temp.: -10 to +70°C/ -40 to +85°C/ -40 to +105°C	-50	+50	×10 ⁻⁶
			Temp.: -10 to +70°C	-30	+30	
			Temp.: -10 to +70°C	-25	+25	
Storage Temperature Range	T _{stg}		-55	+125	°C	
Operating Temperature Range	T _{use}		-10	+70	°C	
			-40	+85		
			-40	+105		
Max. Supply Voltage	—		-0.3	+4.0	V	
Supply Voltage	V _{cc}	CodeⓄ : 1 : 1.5≤F ₀ ≤125MHz	+1.60	+3.63	V	
		CodeⓄ : 2 : 125<F ₀ ≤160MHz	+2.25	+3.63		
Current Consumption (Maximum Loaded)	I _{cc}	1.5≤F ₀ ≤24MHz	1.6≤V _{cc} ≤2.25V	—	2.5	mA
			2.25<V _{cc} ≤2.8V	—	3.0	
			2.8<V _{cc} ≤3.63V	—	3.5	
		24<F ₀ ≤40MHz	1.6≤V _{cc} ≤2.25V	—	3.5	
			2.25<V _{cc} ≤2.8V	—	4.5	
			2.8<V _{cc} ≤3.63V	—	5.0	
		40<F ₀ ≤62.5MHz	1.6≤V _{cc} ≤2.25V	—	5.0	
			2.25<V _{cc} ≤2.8V	—	5.5	
			2.8<V _{cc} ≤3.63V	—	6.0	
		62.5<F ₀ ≤80MHz	1.6≤V _{cc} ≤2.25V	—	6.0	
			2.25<V _{cc} ≤2.8V	—	6.5	
			2.8<V _{cc} ≤3.63V	—	8.0	
		80<F ₀ ≤125MHz	1.6≤V _{cc} ≤2.25V	—	11.0	
			2.25<V _{cc} ≤2.8V	—	14.0	
2.8<V _{cc} ≤3.63V	—		17.0			
125<F ₀ ≤160MHz	2.25<V _{cc} ≤2.8V	—	25.0			
	2.8<V _{cc} ≤3.63V	—	27.0			
Stand-by Current	I _{std}	1.5≤F ₀ ≤80MHz	—	5.0	μA	
		80<F ₀ ≤160MHz	—	10.0		
Symmetry	SYM	@50% V _{cc}	45	55	%	
Rise/ Fall Time (10% to 90% Output Level)	Tr/ Tf	1.5≤F ₀ ≤80MHz	1.6≤V _{cc} ≤2.25V	—	6.0	ns
			2.25<V _{cc} ≤2.8V	—	5.0	
			2.8<V _{cc} ≤3.63V	—	4.5	
		80<F ₀ ≤125MHz	1.6<V _{cc} ≤3.63V	—	4.0	
		125<F ₀ ≤160MHz	2.25<V _{cc} ≤3.63V	—	2.5	
Low Level Output Voltage	V _{OL}	I _{OL} = 4mA (F ₀ ≤80MHz), I _{OL} = 8mA (F ₀ >80MHz)	—	10% V _{cc}	V	
High Level Output Voltage	V _{OH}	I _{OH} = -4mA (F ₀ ≤80MHz), I _{OH} = -8mA (F ₀ >80MHz)	90% V _{cc}	—	V	
Output Load	L _{CMOS}		15		pF	
Low Level Input Voltage	V _{IL}		—	30% V _{cc}	V	
High Level Input Voltage	V _{IH}		70% V _{cc}	—	V	
Disable Time	t _{dis}	1.5≤F ₀ ≤80MHz	—	200	ns	
		80<F ₀ ≤125MHz	—	100		
		125<F ₀ ≤160MHz	—	100		
Enable Time	t _{ena}		—	5	ms	
Start-up Time	t _{str}	1.5≤F ₀ ≤80MHz	@Minimum operating voltage to be 0 sec.	—	5	ms
		80<F ₀ ≤125MHz		—	10	
		125<F ₀ ≤160MHz		—	10	
1 Sigma Jitter	J _{sigma}	1.5≤F ₀ ≤80MHz	Measured with Wavecrest SIA-3000	—	5	ps
		80<F ₀ ≤125MHz		—	4	
		125<F ₀ ≤160MHz		—	3	
Peak to Peak Jitter	J _{PK-PK}	1.5≤F ₀ ≤80MHz		—	50	ps
		80<F ₀ ≤125MHz		—	40	
		125<F ₀ ≤160MHz		—	25	
Phase Jitter	J _{Phase}	@25MHz BW : 12kHz to 20MHz		—	1.0	ps



CMOS/ 1.8V, 2.5V, 3.3V / 2.0×1.6, 2.5×2.0, 3.2×2.5, 5.0×3.2, 7.0×5.0mm

Item	Symbol	Conditions	Min.	Max.	Unit	
Phase Noise	—	@25MHz	@10Hz offset	Typ. -89		dBc/ Hz
			@100Hz offset	Typ. -119		
			@1kHz offset	Typ. -143		
			@10kHz offset	Typ. -157		
			@100kHz offset	Typ. -160		
			@1MHz offset	Typ. -162		
			@10MHz offset	Typ. -162		

Note: All electrical characteristics are defined at the maximum load and operating temperature range.
Note1: Please contact us for inquiry about operating temperature range, available frequencies and other conditions.

Pad Connections	
#1	Stand-by Function
#2	Case GND
#3	Output
#4	Vcc

Stand-by Function	
Pad1	Pad3 (Output)
Open	Active
"H" Level	Active
"L" Level	High Z (No-Oscillation)



CMOS/ 1.8V, 2.5V, 3.3V / 2.0×1.6, 2.5×2.0, 3.2×2.5, 5.0×3.2, 7.0×5.0mm for Automotive

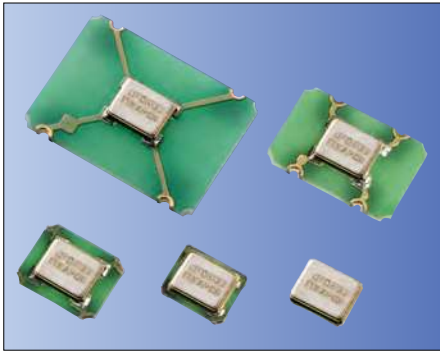

AEC-Q100/200 RoHS Compliant

Features

- Frequency Range 1.5 to 160MHz
- CMOS output
- Wide Supply Voltage
 - 1.6 to 3.63V
- Low current consumption
- Low Phase Noise

Applications

- Automotive Radar/ Camera/ Navigation/ Sensor/ Mirror/ Head light

Table 1

Freq. Code	Tol. × 10 ⁻⁶	Operating Temperature Range (°C)	Note
G	± 50	-40 to +85	Standard specifications
6	± 50	-40 to +105	
X	± 100	-40 to +125	

How to Order

MC2520K 25.0000 C □ □ E SH
① ② ③ ④ ⑤ ⑥ ⑦

- ①Series
- ②Output Frequency (25.0000: 25MHz)
- ③Output Type (C: CMOS)
- ④Supply Voltage

1	1.8V/ 2.5V/ 3.3V compatible
2	2.5V/ 3.3V compatible

- ⑤Frequency Tolerance (See Table 1)
- ⑥Symmetry/ INH Function

E	45/ 55%
---	---------

- ⑦Individual Specification (STD Specification is "SH")

Packaging Tape & Reel

MC7050K/ MC5032K	1000 pcs./ reel
MC3225K/ MC2520K/ MC2016K	2000 pcs./ reel

Dimensions

(Unit: mm)

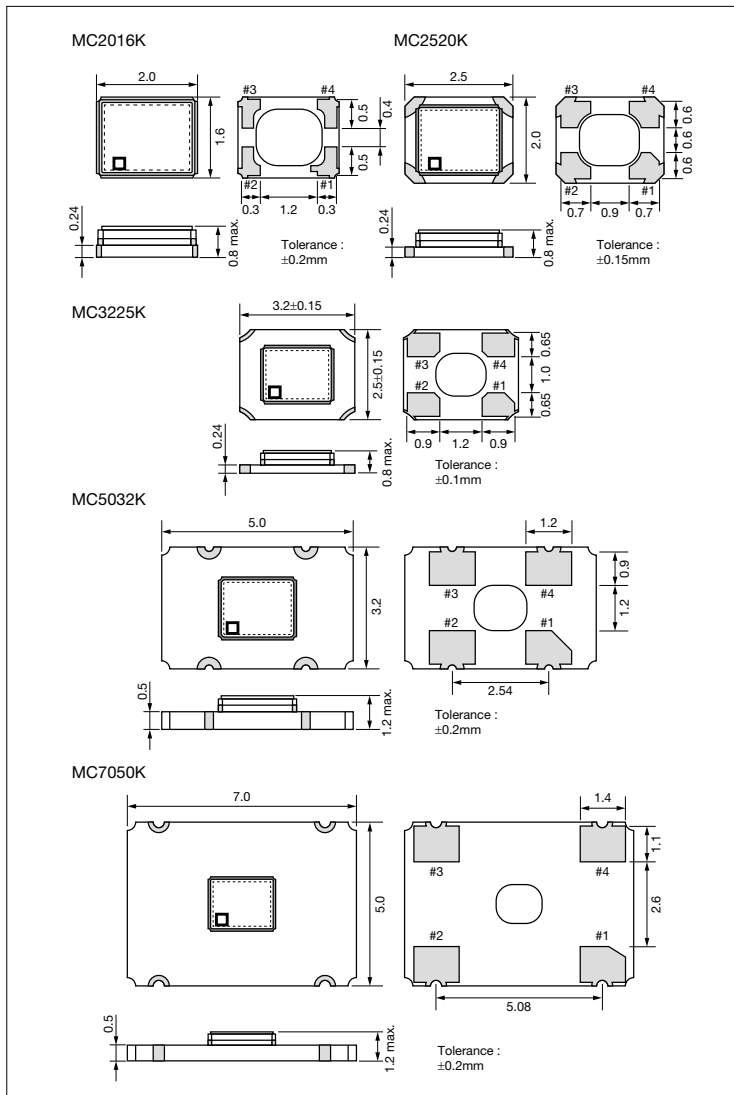

Recommended Land Pattern

(Unit: mm)

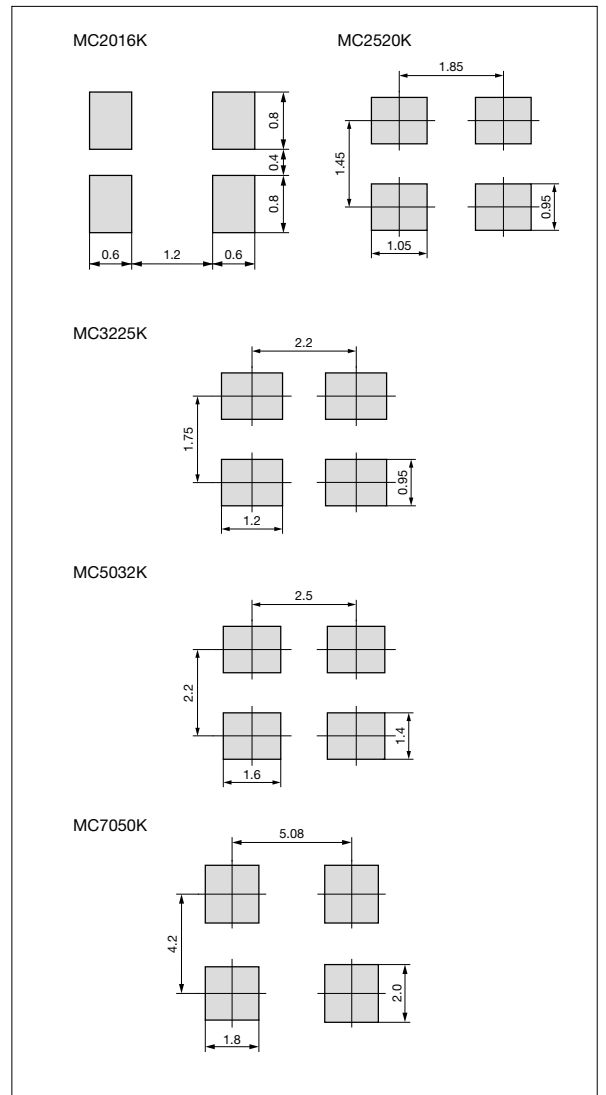



CMOS/ 1.8V, 2.5V, 3.3V / 2.0×1.6, 2.5×2.0, 3.2×2.5, 5.0×3.2, 7.0×5.0mm for Automotive

Specifications

Item	Symbol	Conditions	Min.	Max.	Unit	
Output Frequency Range ^{Note1}	f _o		1.5	160	MHz	
Frequency Tolerance	f _{tol}	Initial tolerance, Operating temperature range, Rated power supply voltage change, Load change, Aging (1 year @25°C), Shock and vibration	Temp.: -40 to +85°C/ -40 to +105°C	-50	+50	×10 ⁻⁶
			Temp.: -40 to +125°C	-100	+100	
Storage Temperature Range	T _{stg}		-55	+125	°C	
Operating Temperature Range	T _{use}		-40	+85	°C	
			-40	+105		
			-40	+125		
Max. Supply Voltage	—		-0.3	+4.0	V	
Supply Voltage	V _{cc}	CodeⓄ : 1 : 1.5≤F ₀ ≤125MHz	+1.60	+3.63	V	
		CodeⓄ : 2 : 125<F ₀ ≤160MHz	+2.25	+3.63		
Current Consumption (Maximum Loaded)	I _{cc}	1.5≤F ₀ ≤24MHz	1.6≤V _{cc} ≤2.25V	—	2.5	mA
			2.25<V _{cc} ≤2.8V	—	3.0	
			2.8<V _{cc} ≤3.63V	—	3.5	
		24<F ₀ ≤40MHz	1.6≤V _{cc} ≤2.25V	—	3.5	
			2.25<V _{cc} ≤2.8V	—	4.5	
			2.8<V _{cc} ≤3.63V	—	5.0	
		40<F ₀ ≤62.5MHz	1.6≤V _{cc} ≤2.25V	—	5.0	
			2.25<V _{cc} ≤2.8V	—	5.5	
			2.8<V _{cc} ≤3.63V	—	6.0	
		62.5<F ₀ ≤80MHz	1.6≤V _{cc} ≤2.25V	—	6.0	
			2.25<V _{cc} ≤2.8V	—	6.5	
			2.8<V _{cc} ≤3.63V	—	8.0	
		80<F ₀ ≤125MHz	1.6≤V _{cc} ≤2.25V	—	11.0	
			2.25<V _{cc} ≤2.8V	—	14.0	
			2.8<V _{cc} ≤3.63V	—	17.0	
		125<F ₀ ≤160MHz	2.25<V _{cc} ≤2.8V	—	25.0	
2.8<V _{cc} ≤3.63V	—		27.0			
Stand-by Current	I _{std}	1.5≤F ₀ ≤80MHz	—	5.0	μA	
		80<F ₀ ≤160MHz	—	10.0		
Symmetry	SYM	@50% V _{cc}	45	55	%	
Rise/ Fall Time (10% to 90% Output Level)	Tr/ Tf	1.5≤F ₀ ≤80MHz	1.6≤V _{cc} ≤2.25V	—	6.0	ns
			2.25<V _{cc} ≤2.8V	—	5.0	
			2.8<V _{cc} ≤3.63V	—	4.5	
		80<F ₀ ≤125MHz	1.6<V _{cc} ≤3.63V	—	4.0	
		125<F ₀ ≤160MHz	2.25<V _{cc} ≤3.63V	—	2.5	
Low Level Output Voltage	V _{OL}	I _{OL} = 4mA (F ₀ ≤80MHz), I _{OL} = 8mA (F ₀ >80MHz)	—	10% V _{cc}	V	
High Level Output Voltage	V _{OH}	I _{OH} = -4mA (F ₀ ≤80MHz), I _{OH} = -8mA (F ₀ >80MHz)	90% V _{cc}	—	V	
Output Load	L _{CMOS}		15		pF	
Low Level Input Voltage	V _{IL}		—	30% V _{cc}	V	
High Level Input Voltage	V _{IH}		70% V _{cc}	—	V	
Disable Time	t _{dis}	1.5≤F ₀ ≤80MHz	—	200	ns	
		80<F ₀ ≤125MHz	—	100		
		125<F ₀ ≤160MHz	—	100		
Enable Time	t _{ena}		—	5	ms	
Start-up Time	t _{str}	1.5≤F ₀ ≤80MHz	@Minimum operating voltage to be 0 sec.	—	5	ms
		80<F ₀ ≤125MHz		—	10	
		125<F ₀ ≤160MHz		—	10	
1Sigma Jitter	J _{sigma}	1.5≤F ₀ ≤80MHz	Measured with Wavecrest SIA-3000	—	5	ps
		80<F ₀ ≤125MHz		—	4	
		125<F ₀ ≤160MHz		—	3	
Peak to Peak Jitter	J _{PK-PK}	1.5≤F ₀ ≤80MHz		—	50	ps
		80<F ₀ ≤125MHz		—	40	
		125<F ₀ ≤160MHz		—	25	
Phase Jitter	J _{Phase}	@25MHz	BW : 12kHz to 20MHz	—	1.0	ps



CMOS/ 1.8V, 2.5V, 3.3V / 2.0×1.6, 2.5×2.0, 3.2×2.5, 5.0×3.2, 7.0×5.0mm for Automotive

Item	Symbol	Conditions	Min.	Max.	Unit
Phase Noise	—	@25MHz	@10Hz offset	Typ. -89	dBc/ Hz
			@100Hz offset	Typ. -119	
			@1kHz offset	Typ. -143	
			@10kHz offset	Typ. -157	
			@100kHz offset	Typ. -160	
			@1MHz offset	Typ. -162	
			@10MHz offset	Typ. -162	

Note: All electrical characteristics are defined at the maximum load and operating temperature range.
Note1: Please contact us for inquiry about operating temperature range, available frequencies and other conditions.

Pad Connections	
#1	Stand-by Function
#2	Case GND
#3	Output
#4	Vcc

Stand-by Function	
Pad1	Pad3 (Output)
Open	Active
"H" Level	Active
"L" Level	High Z (No-Oscillation)



1.6×1.2mm



Features

- Ultra-miniature SMD type (1.65×1.25×0.55mm)
- Low Phase Noise : -164dBc/ Hz@100kHz offset, 52MHz
- With Disable Function
- Freq. temp. characteristics. : ±2.0×10⁻⁶/ -30 to +85°C : ±0.5×10⁻⁶/ -30 to +85°C (for GNSS)
- 1.68 to 3.63V drive available
- Reflow compatible

Applications

- Mobile communications, Wireless modules
- GNSS Unit
- Wi-Fi 6 (IEEE802.11ax)
- Networking equipments

*Wi-Fi® is a registered trademark of Wi-Fi Alliance.

How to Order

KT1612A 52000 □ □ □ □ N x G
① ② ③ ④ ⑤ ⑥ ⑦ ⑧ ⑨

①Series

KT1612A 1612 Size

②Output Frequency

③Freq. Temp. Chrst.

A	±0.5×10 ⁻⁶
B	±1.0×10 ⁻⁶
C	±1.5×10 ⁻⁶
D	±2.0×10 ⁻⁶

④Lower Operating Temp.

C	-30°C
E	-20°C
G	-10°C

⑤Upper Operating Temp.

W	+85°C
V	+80°C
U	+75°C

⑥Supply Voltage

18	1.8V	28	2.8V
30	3.0V	33	3.3V

⑦Disable Function

N With Disable Function

⑧Individual Specification

⑨Low Phase Noise Type

G Low Phase Noise

Packaging (Tape & Reel 18000 pcs./ reel)

Specifications

Item	Symbol	Conditions	Min.	Max.	Units
Output Frequency Range	fo	Standard Output Frequency: 19.2, 26.0, 38.4, 48.0, 52.0, 76.8	19.2	76.8	MHz
Frequency Tolerance	f _{tol}	vs Temperature	-0.5/ -2	+0.5/ +2	×10 ⁻⁶
		vs Load	-0.1	+0.1	
		vs Voltage	-0.1	+0.1	
Frequency Aging	f _{age}	Per Year	-1	+1	×10 ⁻⁶
Storage Temperature Range	T _{stg}		-40	+85	°C
Operating Temperature Range	T _{use}		-30	+85	°C
Supply Voltage	V _{cc}		1.68	3.63	V
Output Level	V _{pp}	Clipped Sine*, Load: 10k ohm // 10pF	0.8	—	V _{p-p}
Current Consumption	I _{cc}		—	3	mA
Harmonics	—		—	-5	dBc

* : A DC-cut capacitor is not embedded in this crystal oscillator. Connect a DC-cut capacitor (≥1nF) to the line-out terminal of the oscillator.

* Please contact us for other specifications.

Dimensions

(Unit: mm)

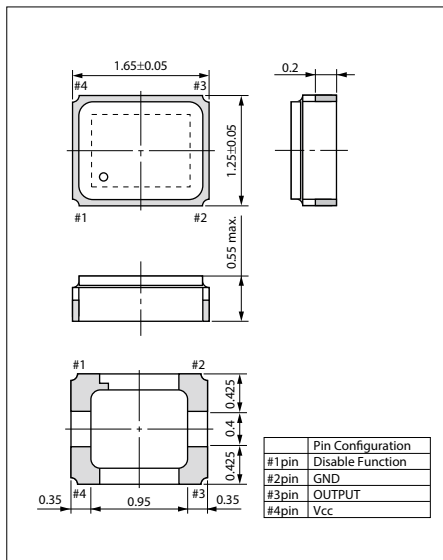

Test Circuit

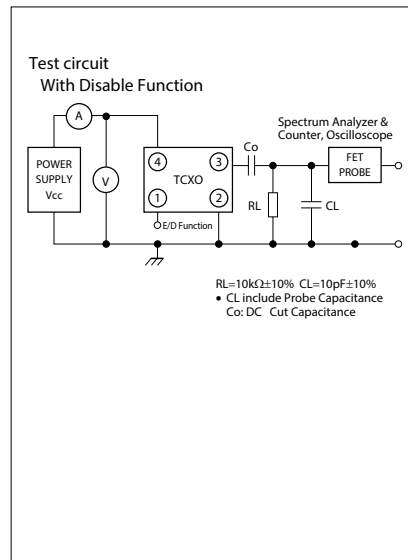

Recommended Land Pattern

(Unit: mm)

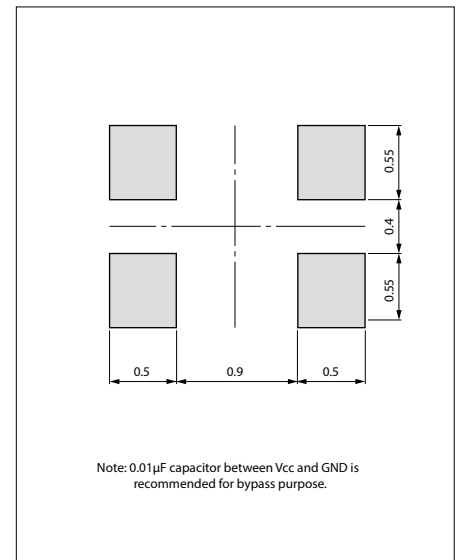



1.6×1.2mm



RoHS Compliant

Features

- Ultra-miniature SMD type (1.65×1.25×0.55mm)
- Freq. temp. characteristics:
: ±2.0×10⁻⁶/ -30 to +85°C
: ±0.5×10⁻⁶/ -30 to +85°C (for GNSS)
- 1.68 to 3.63V drive available
- Reflow compatible
- Operating Temp. -40 to +105°C (Option)
- Disable Function (Option)

Applications

- Mobile Communications, W-LAN
- Low power radio communications
- GNSS Unit

How to Order

KT1612A 26000 □ □ □ □ □ xx
① ② ③ ④ ⑤ ⑥ ⑦ ⑧

①Series

②Output Frequency

③Freq. Temp. Chrst.

A	±0.5×10 ⁻⁶
B	±1.0×10 ⁻⁶
C	±1.5×10 ⁻⁶
D	±2.0×10 ⁻⁶

④Lower Operating Temp.

C	-30°C
E	-20°C
G	-10°C

⑤Upper Operating Temp.

W	+85°C
V	+80°C
U	+75°C

⑥Supply Voltage

18	1.8V	28	2.8V
30	3.0V	33	3.3V

⑦Voltage Control Function

T	TCXO
Spec. Code*	VCTCXO

*Please contact us for Spec. Code.

⑧Individual Specification

Packaging (Tape & Reel 18000 pcs./ reel)

Specifications

Item	Symbol	Conditions	Min.	Max.	Unit
Output Frequency Range	f _o	Standard Output Frequency: 19.2, 26.0, 38.4, 48.0, 52.0, 76.8	19.2	76.8	MHz
Frequency Tolerance	f _{tol}	vs Temperature	-0.5/ -2	+0.5/ +2	×10 ⁻⁶
		vs Load	-0.2	+0.2	
		vs Voltage	-0.2	+0.2	
Frequency Aging	f _{age}	Per Year	-1	+1	×10 ⁻⁶
Storage Temperature Range	T _{stg}		-40	+85	°C
Operating Temperature Range	T _{use}		-30	+85	°C
Voltage Control Range	f _{cont}	Positive	±8	±15	×10 ⁻⁶
Supply Voltage	V _{cc}		1.68	3.63	V
Output Level	V _{pp}	Clipped Sine*, Load: 10k ohm // 10pF	0.8	—	Vp-p
Current Consumption	I _{cc}		—	2	mA
Harmonics	—		—	-5	dBc

*: A DC-cut capacitor is not embedded in this crystal oscillator. Connect a DC-cut capacitor (≥1nF) to the line-out terminal of the oscillator.

* Please contact us for other specifications.

Dimensions

(Unit: mm)

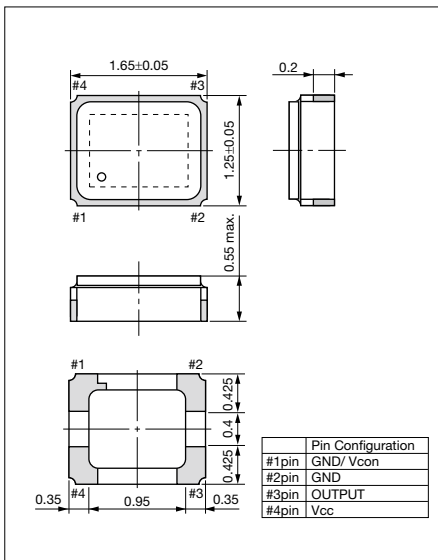

Test Circuit

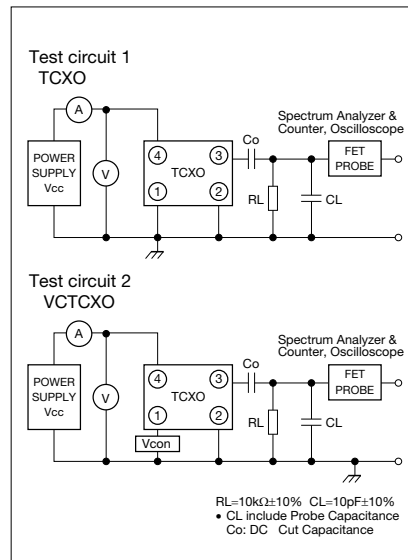

Recommended Land Pattern

(Unit: mm)

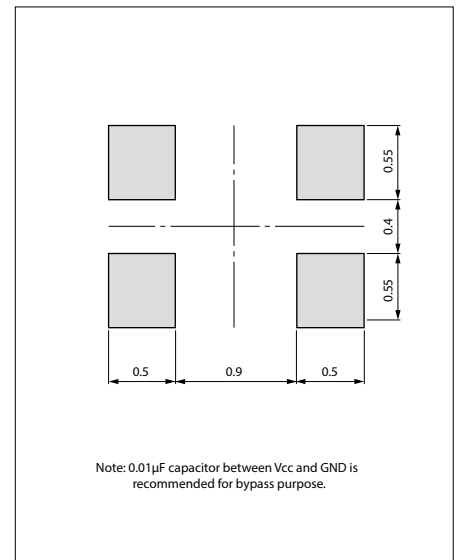



2.0×1.6mm



AEC-Q100/200 **RoHS Compliant**
*AEC-Q100 qualified (Option)

Features

- Miniature SMD type (2.0×1.6×0.8mm)
- Freq. temp. characteristics:
: $\pm 2.0 \times 10^{-6}/-30$ to $+85^\circ\text{C}$
: $\pm 0.5 \times 10^{-6}/-30$ to $+85^\circ\text{C}$ (for GNSS)
- 1.68 to 3.63V available
- Reflow compatible
- Operating Temp. -40 to $+105^\circ\text{C}$ (Option)
- Disable Function (Option)

Applications

- Mobile Communications, W-LAN
- Low power radio communications
- GNSS Unit

How to Order

KT2016K 26000 □ □ □ □ □ xx
① ② ③ ④ ⑤ ⑥ ⑦ ⑧

①Series

②Output Frequency

③Freq. Temp. Chrst.

A	$\pm 0.5 \times 10^{-6}$
B	$\pm 1.0 \times 10^{-6}$
C	$\pm 1.5 \times 10^{-6}$
D	$\pm 2.0 \times 10^{-6}$

④Lower Operating Temp.

C	-30°C
E	-20°C
G	-10°C

⑤Upper Operating Temp.

W	$+85^\circ\text{C}$
V	$+80^\circ\text{C}$
U	$+75^\circ\text{C}$

⑥Supply Voltage

18	1.8V	28	2.8V
30	3.0V	33	3.3V

⑦Voltage Control Function

T	TCXO
Spec. Code*	VCTCXO

*Please contact us for Spec. Code.

⑧Individual Specification

Packaging (Tape & Reel 15000 pcs./ reel)

Specifications

Item	Symbol	Conditions	Min.	Max.	Unit
Output Frequency Range	f_o	Standard Output Frequency: 19.2, 26.0, 32.0, 38.4, 48.0, 52.0	19.2	52	MHz
Frequency Tolerance	f_{tol}	vs Temperature	$-0.5/ -2$	$+0.5/ +2$	$\times 10^{-6}$
		vs Load	-0.2	$+0.2$	
		vs Voltage	-0.2	$+0.2$	
Frequency Aging	f_{age}	Per Year	-1	$+1$	$\times 10^{-6}$
Storage Temperature Range	T_{stg}		-40	$+85$	$^\circ\text{C}$
Operating Temperature Range	T_{use}		-30	$+85$	$^\circ\text{C}$
Voltage Control Range	f_{cont}	Positive	± 8	± 15	$\times 10^{-6}$
Supply Voltage	V_{cc}		1.68	3.63	V
Output Level	V_{pp}	Clipped Sine*, Load: 10k ohm // 10pF	0.8	—	Vp-p
Current Consumption	I_{cc}		—	2	mA
Harmonics	—		—	-5	dBc

*: A DC-cut capacitor is not embedded in this crystal oscillator. Connect a DC-cut capacitor ($\geq 1\text{nF}$) to the line-out terminal of the oscillator.

* Please contact us for other specifications.

Dimensions

(Unit: mm)

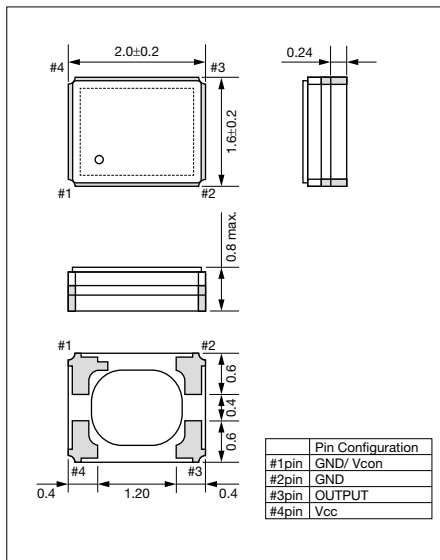

Test Circuit

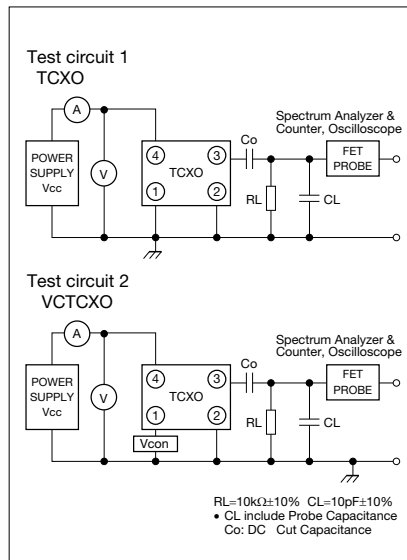

Recommended Land Pattern

(Unit: mm)

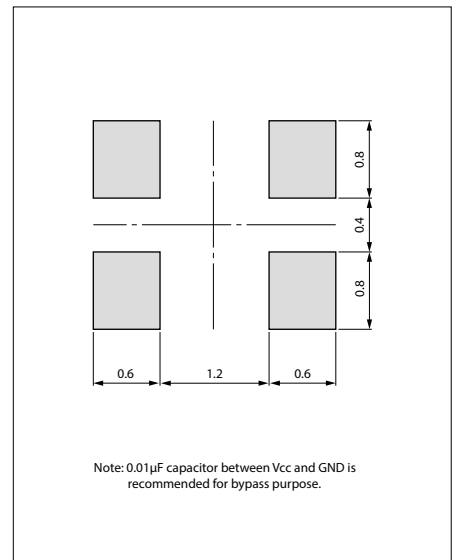



2.5×2.0mm

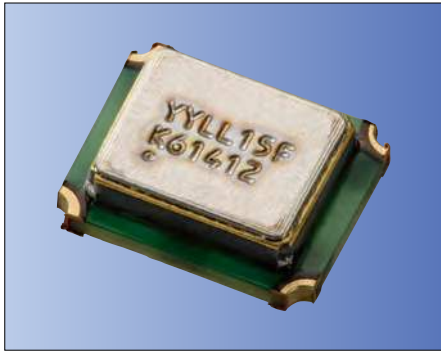

AEC-Q100/200 **RoHS Compliant**
*AEC-Q100 qualified (Option)

Features

- Miniature SMD type (2.5×2.0×0.8mm)
- Freq. temp. characteristics:
: $\pm 2.0 \times 10^{-6} / -30$ to $+85^\circ\text{C}$
: $\pm 0.5 \times 10^{-6} / -30$ to $+85^\circ\text{C}$ (for GNSS)
- 1.68 to 3.63V drive available
- Reflow compatible
- Operating Temp. -40 to $+105^\circ\text{C}$ (Option)
- Disable Function (Option)

Applications

- Mobile Communications, W-LAN
- Low power radio communications
- GNSS Unit

How to Order

KT2520K 26000 □ □ □ □ □ xx
① ② ③ ④ ⑤ ⑥ ⑦ ⑧

① Series

A	$\pm 0.5 \times 10^{-6}$
B	$\pm 1.0 \times 10^{-6}$
C	$\pm 1.5 \times 10^{-6}$
D	$\pm 2.0 \times 10^{-6}$

④ Lower Operating Temp.

C	-30°C
E	-20°C
G	-10°C

⑤ Upper Operating Temp.

W	$+85^\circ\text{C}$
V	$+80^\circ\text{C}$
U	$+75^\circ\text{C}$

⑥ Supply Voltage

18	1.8V	28	2.8V
30	3.0V	33	3.3V

⑦ Voltage Control Function

T	TCXO
Spec. Code*	VCTCXO

*Please contact us for Spec. Code.

⑧ Individual Specification

Packaging (Tape & Reel 12000 pcs./ reel)

Specifications

Item	Symbol	Conditions	Min.	Max.	Unit
Output Frequency Range	fo	Standard Output Frequency: 19.2, 26.0, 32.0, 38.4, 48.0, 52.0	19.2	52	MHz
Frequency Tolerance	f _{tol}	vs Temperature	-0.5/ -2	+0.5/ +2	$\times 10^{-6}$
		vs Load	-0.2	+0.2	
		vs Voltage	-0.2	+0.2	
Frequency Aging	f _{age}	Per Year	-1	+1	$\times 10^{-6}$
Storage Temperature Range	T _{stg}		-40	+85	$^\circ\text{C}$
Operating Temperature Range	T _{use}		-30	+85	$^\circ\text{C}$
Voltage Control Range	f _{cont}	Positive	± 8	± 15	$\times 10^{-6}$
Supply Voltage	V _{cc}		1.68	3.63	V
Output Level	V _{pp}	Clipped Sine*, Load: 10k ohm // 10pF	0.8	—	Vp-p
Current Consumption	I _{cc}		—	2	mA
Harmonics	—		—	-5	dBc

* : A DC-cut capacitor is not embedded in this crystal oscillator. Connect a DC-cut capacitor ($\geq 1\text{nF}$) to the line-out terminal of the oscillator.

* Please contact us for other specifications.

Dimensions

(Unit: mm)

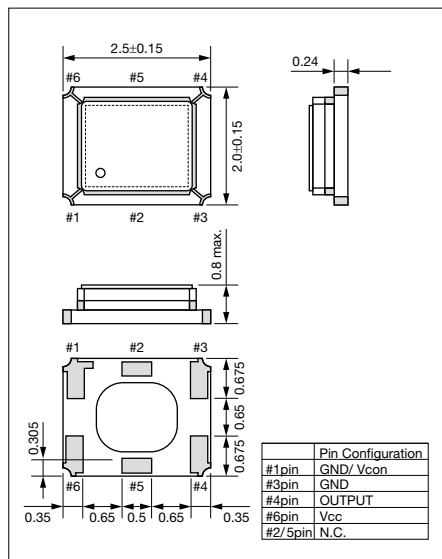

Test Circuit

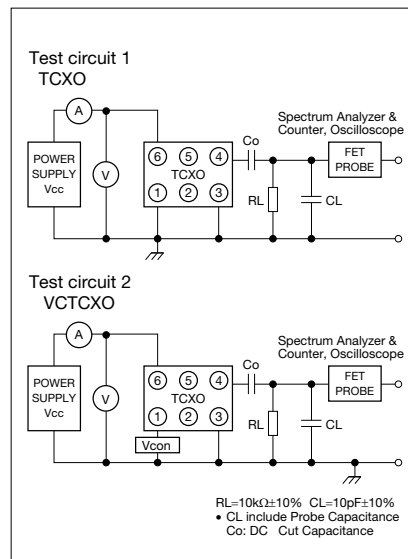

Recommended Land Pattern

(Unit: mm)

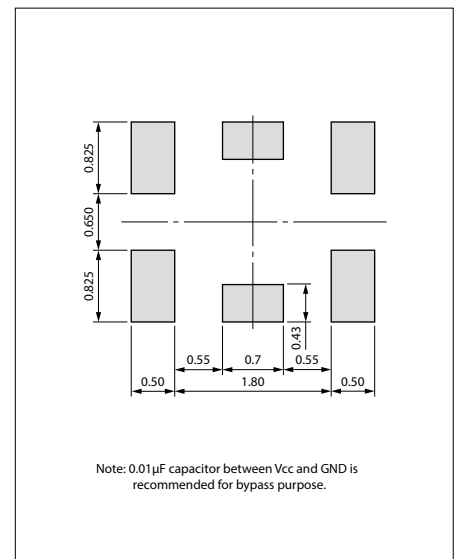



5.0×3.2mm

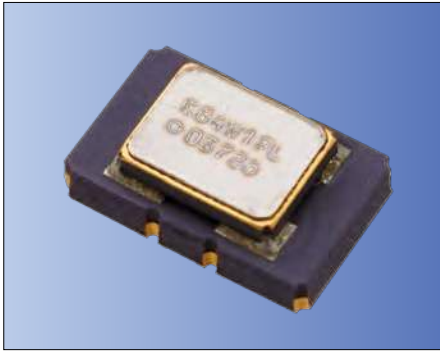

RoHS Compliant

Features

- High stability and high reliability
- 2.3 to 3.63V drive available
- Clipped sine wave or CMOS level output
- Low phase noise
- Operating Temp. -40 to +105°C (Option)

Applications

- 5G, Smallcell, Stratum3
- SONET/ SDH/ Ethernet
- SyncE/ IEEE 1588

How to Order

KT5032F	20000	□	□□	33	T	xx
①	②	③	④	⑤	⑥	⑦
①Series	②Output Frequency			④Operating Temperature Range		
③Frequency Tolerance	⑤Supply Voltage			⑥Voltage Control Function		
U ±0.5×10 ⁻⁶	K ±0.28×10 ⁻⁶	A ±0.1×10 ⁻⁶	GT -10°C to 70°C	AW -40°C to 85°C	AY -40°C to 105°C	T TCXO
33	3.3V		Spec. Code* VCTCXO			

*Please contact us for Spec. Code.

⑦Individual Specification

Packaging (Tape & Reel 1000 pcs./ reel)

Specifications

Item	Symbol	Conditions	Min.	Max.	Unit	
Output Frequency Range	f _o	Standard Frequency: 10, 19.2, 20, 24.576, 26, 30.72, 38.88, 40	10	40	MHz	
Frequency Tolerance	f _{tol}	vs Temperature [±(f _{max} -f _{min})/ 2fo]	-0.5	+0.5	×10 ⁻⁶	
		vs Voltage	-0.28	+0.28		
Supply Voltage	V _{CC}		+2.3	+3.63	V	
Current Consumption	I _{CC}	CMOS Output	—	6	mA	
Frequency Aging	f _{age}	20years aging @40°C Including temp characteristics, initial tolerance, rated power supply voltage change and load change.	-4.6	+4.6	×10 ⁻⁶	
Voltage Control Range	f _{cont}	Positive *100k ohm min	±5	±20	×10 ⁻⁶	
Output Level	V _{pp}	Clipped Sine*, Load: 10k ohm // 10pF	0.8	—	Vp-p	
Low Level Output Voltage	V _{OL}	CMOS, Load: 15pF I _{OL} =4mA	—	10% V _{CC}	V	
High Level Output Voltage	V _{OH}	CMOS, Load: 15pF I _{OH} =-4mA	90% V _{CC}	—	V	
Rise / Fall Time (10%V _{CC} to 90%V _{CC})	Tr/ Tf	CMOS, Load: 15pF	—	8	ns	
Symmetry	SYM	50% V _{CC}	45	55	%	
Phase Noise	—	@20MHz	@10Hz offset	—	-90	dBc/ Hz
			@100Hz offset	—	-120	
			@1kHz offset	—	-140	
			@10kHz offset	—	-150	
			@100kHz offset	—	-150	

* : A DC-cut capacitor is not embedded in this crystal oscillator. In case of clipped sine output, connect a DC-cut capacitor (≥1nF) to the line-out terminal of the oscillator.
* Please contact us for other specifications.

Dimensions

(Unit: mm)

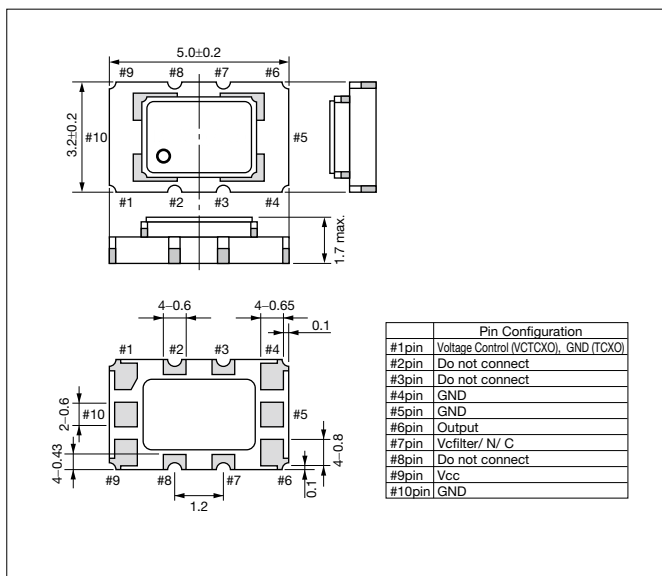

Recommended Land Pattern

(Unit: mm)

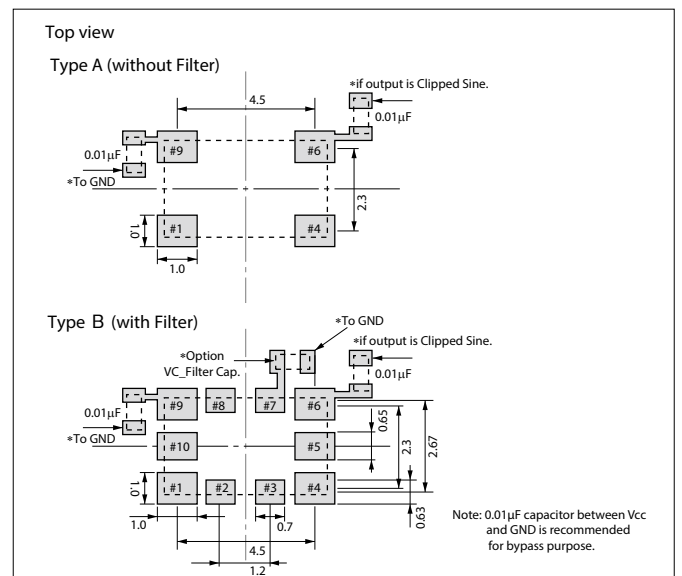



7.0x5.0mm

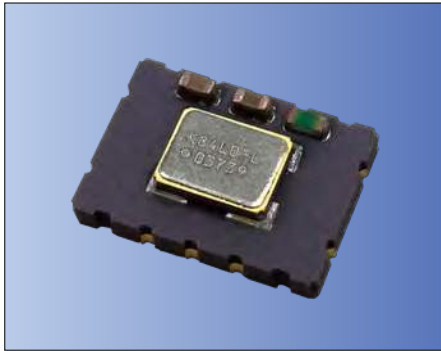

RoHS Compliant

Features

- High stability and high reliability
- 2.3 to 3.63V drive available
- Clipped sine wave or CMOS level output
- Low phase noise
- Disable Function (KT7050A)
- Operating Temp. -40 to +105°C (Option)

Applications

- 5G, Smallcell, Stratum3
- SONET/ SDH/ Ethernet
- SyncE/ IEEE 1588

How to Order

KT7050 □ 20000 □ □ □ 33 T xx
① ② ③ ④ ⑤ ⑥ ⑦ ⑧

①Series

③Output Frequency

④Freq. Temp. Chrst.

U	$\pm 0.5 \times 10^{-6}$
K	$\pm 0.28 \times 10^{-6}$
A	$\pm 0.1 \times 10^{-6}$

⑥Supply Voltage

33	3.3V
----	------

②Land Type

A	10Pads
B	4Pads

③Operating Temperature Range

GT	-10°C to 70°C
AW	-40°C to 85°C
AY	-40°C to 105°C

⑦Voltage Control Function

T	TCXO
Spec. Code*	VCTCXO

*Please contact us for Spec. Code.

⑨Individual Specification

Packaging (Tape & Reel 1000 pcs./ reel)

- Compliant to the GR1244-Core & GR253-Core
- Recommended in Microsemi's ZLAN-68 app. note for Stratum3 applications based on tests performed by Kyocera.

Specifications

Item	Symbol	Conditions	Min.	Max.	Unit	
Output Frequency Range	fo	Standard Frequency: 10, 19.2, 20, 24.576, 26, 30.72, 38.88, 40	10	40	MHz	
Frequency Tolerance	f _{tol}	vs Temperature $[\pm(f_{max}-f_{min})/2f_0]$	-0.5	+0.5	$\times 10^{-6}$	
			-0.28	+0.28		
			-0.1	+0.1		
Supply Voltage	V _{CC}		+2.3	+3.63	V	
Current Consumption	I _{CC}	CMOS Output	—	6	mA	
Frequency Aging	f _{age}	20years aging @40°C Including temp characteristics, initial tolerance, rated power supply voltage change and load change.	-4.6	+4.6	$\times 10^{-6}$	
Voltage Control Range	f _{cont}	Positive *100k ohm min	± 5	± 20	$\times 10^{-6}$	
Output Level	V _{pp}	Clipped Sine, Load: 10k ohm // 10pF	0.8	—	Vp-p	
Low Level Output Voltage	V _{OL}	CMOS, Load: 15pF I _{OL} =4mA	—	10% V _{CC}	V	
High Level Output Voltage	V _{OH}	CMOS, Load: 15pF I _{OH} =-4mA	90% V _{CC}	—	V	
Rise / Fall Time (10%V _{CC} to 90%V _{CC})	Tr/ Tf	CMOS, Load: 15pF	—	8	ns	
Symmetry	SYM	50% V _{CC}	45	55	%	
Phase Noise	—	@20MHz	@10Hz offset	—	-90	dBc/ Hz
			@100Hz offset	—	-120	
			@1kHz offset	—	-140	
			@10kHz offset	—	-150	
			@100kHz offset	—	-150	

* Please contact us for other specifications.

Dimensions

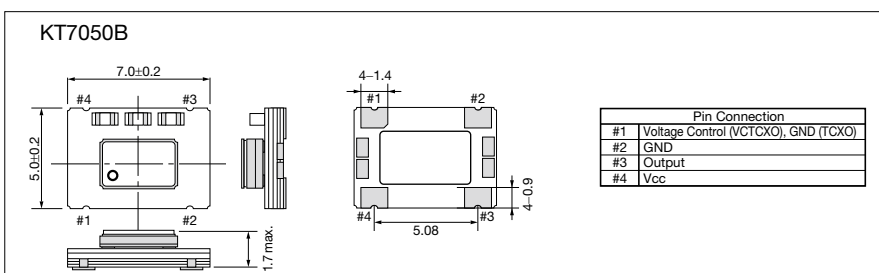
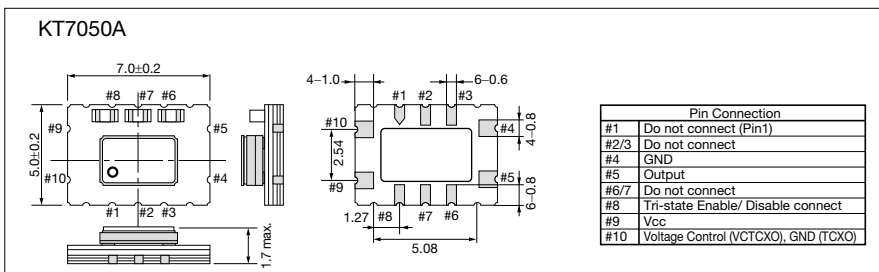

Recommended Land Pattern (Unit: mm)

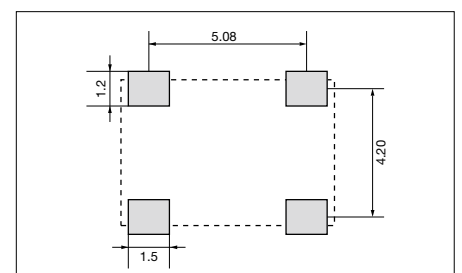
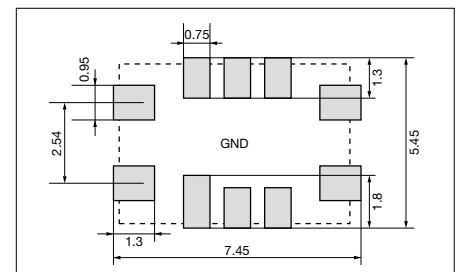



1. Shock & Drop / Vibration

Do not inflict excessive shock and mechanical vibration that exceeds the norm, such as hitting or mistakenly dropping, when transporting and mounting on a board. There are cases when pieces of crystal break, and pieces that are used become damaged, and become inoperable. When a shock or vibration that exceeds the norm has been inflicted, make sure to check the characteristics.

2. Cleaning

Since a crystal piece can be broken by resonance when a crystal device is cleaned by ultrasonic cleaning, be careful when carrying out ultrasonic cleaning.

3. Soldering conditions

To maintain the product reliability, please follow recommended conditions.

Standard soldering iron conditions

	Clock Oscillators
Soldering iron	280°C to 340°C
Time	3+1/ -0 sec. max.

Reflow conditions (Example)

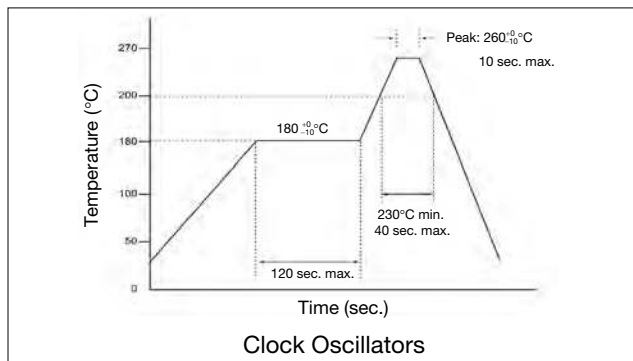

Recommended reflow Conditions vary depending upon products. Please check with the respective specification for details.

4. Mounting Precautions

The lead of the device and the pattern of the board is soldered on the surface. Since extreme deformation of the board tears off the pattern, tears off the lead metal, cracks the solder and damages the sealed part of the device and there are cases in which performance deteriorates and operation fails, use it within the stipulated bending conditions. Due to the small cracks in the board resulting from mounting, please pay sufficient attention when attaching a device at the position where the warping of the board is great.

When using an automatic loading machine, as far as possible, select a type that has a small impact and use it while confirming that there is no damage.

Surface mount devices are NOT flow soldering compatible.

5. Storage Condition

Since the long hour high temperature and low temperature storage, as well as the storage at high humidity are causes of deterioration in frequency accuracy and solderability.

Parts should be stored in temperature range of -5 to +40°C, humidity 40 to 60% RH, and avoid direct sunlight. Then use within 6 months.



6. In order to use clock oscillators

- (1) The miniature oscillator for the clock utilizes a CMOS IC and incorporates a protective circuit against static electricity. However, exercise care in the same manner as for a normal CMOS IC.
- (2) Internal capacitor is not provided in the power supply section (+DC-GND).
To serve as overimpressed voltage and overcurrent protective device, place a bypass capacitor (0.01 μ F) as near as possible to the (+DC-GND) terminal. However, the capacitance value is meant as a guideline. Depending on the capacitor type, frequency characteristics vary. Accordingly, use a capacitor that matches the frequency characteristics.
- (3) Applying reverse voltage could result in damage to internal parts. Take care not to connect terminals incorrectly.
- (4) Please do not use oscillators under unfavorable condition such as beyond specified range in catalog or specification sheet.
- (5) Please keep oscillators away from water, salt water or harmful gas.
- (6) Frequency drift may occur as a result of application of light such as direct sunlight or LED light etc when operating clock oscillator Z series MC-Z series.
Please use in a design and environment that consider light shielding.
Note the frequency drift will not occur if used in a light-shielded environment.

Clock Timing Chart

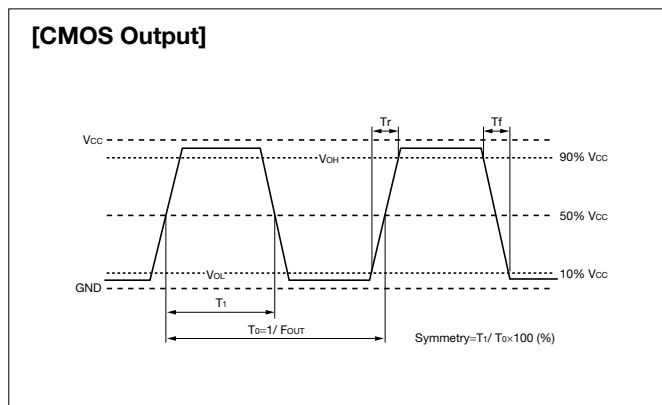

Test Circuits

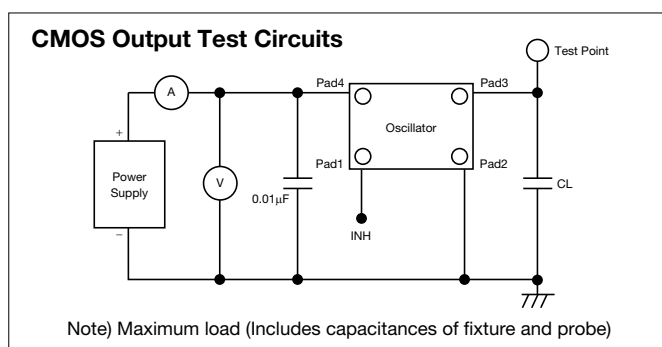

Tape & Reel Specifications

■Clock Oscillators

■Temperature Compensated Crystal Oscillators (TCXO)

		KC2016K KC2016Z MC2016K MC2016Z	KC2520K KC2520Z MC2520K MC2520Z	KC3225K KC3225Z MC3225K MC3225Z	KC5032K KC5032Z MC5032K MC5032Z	KC7050K KC7050Z MC7050K MC7050Z	KT1612A	KT2016K	KT2520K	KT5032F	KT7050
T A P E	A	2.0±0.05	2.0±0.05	2.0±0.05	1.5+0.1/ -0	2.0±0.1	2.0±0.05	2.0±0.05	2.0±0.05	2.0±0.05	2.0±0.1
	B	4.0±0.1	4.0±0.1	4.0±0.1	4.0±0.1	4.0±0.1	4.0±0.05	4.0±0.1	4.0±0.1	4.0±0.1	4.0±0.1
	C	φ1.5+0.1/ -0	φ1.5+0.1/ -0	φ1.5+0.1/ -0	φ1.5+0.1/ -0	φ1.5±0.1	φ1.5+0.1/ -0	φ1.5+0.1/ -0	φ1.5+0.1/ -0	φ1.55±0.05	φ1.5+0.1/ -0
	D	4.0±0.1	4.0±0.1	4.0±0.1	8.0±0.1	8.0±0.1	4.0±0.1	4.0±0.1	4.0±0.1	8.0±0.1	8.0±0.1
	E	3.5±0.05	3.5±0.05	3.5±0.05	5.5±0.05	7.5±0.1	3.5±0.05	3.5±0.05	3.5±0.05	5.5±0.05	7.5±0.1
	F	1.75±0.1	1.75±0.1	1.75±0.1	1.75±0.1	1.75±0.1	1.75±0.1	1.75±0.1	1.75±0.1	1.75±0.1	1.75±0.1
	G	8.0±0.2	8.0±0.2	8.0±0.2	12.0±0.3	16.0±0.2	8.0±0.2	8.0±0.2	8.0+0.3/ -0.2	12.0±0.2	16.0+0.3/ -0.1
	H	φ1.05±0.1	φ1.1±0.1	φ1.5+0.1/ 0	φ1.5+0.1/ 0	φ1.55±0.1	φ0.5±0.05	φ1.0+0.1/ -0	φ1.1±0.1	φ1.55±0.05	φ1.55±0.05
	J	2.25±0.1	2.7±0.1	3.5±0.05	5.5±0.1	7.4±0.1	1.85±0.1	2.4±0.05	2.9±0.1	5.9±0.1	8.21±0.1
	L	1.85±0.1	2.2±0.1	2.8±0.05	3.7±0.1	5.4±0.1	1.45±0.1	2.0±0.05	2.4±0.1	3.7±0.1	5.78±0.1
	N	0.95±0.1	1.0±0.1	1.1±0.05	1.4±0.1	2.0±0.1	0.65±0.05	0.9±0.05	1.15±0.1	2.0±0.1	2.16±0.1
O	0.2±0.05	0.2±0.05	0.25±0.05	0.3±0.05	0.3±0.05	0.2±0.05	0.25±0.05	0.25±0.05	0.3±0.05	0.3±0.05	
R E E L	P	φ180+0/ -3	φ180+0/ -3	φ180+0/ -3	φ180+0/ -3	φ180+0/ -3	φ330+0/ -2	φ330+0/ -2	φ330+0/ -2	φ254±2.0	φ254±2.0
	Q	φ60+1/ -0	φ60+1/ -0	φ60+1/ -0	φ60+1/ -0	φ60+1/ -0	φ100±1.0	φ100±1.0	φ100±1.0	φ100±1.0	φ100+1.0/ -0
	R	φ13±0.2	φ13±0.2	φ13±0.2	φ13±0.2	φ13±0.2	φ13±0.2	φ13±0.2	φ13±0.2	φ13±0.2	φ13±0.2
	S	φ21±0.8	φ21±0.8	φ21±0.8	φ21±0.8	φ21±0.8	φ21±0.8	φ21±0.8	φ21±0.8	φ21±0.8	φ21±0.8
	U	2.0±0.5	2.0±0.5	2.0±0.5	2.0±0.5	2.0±0.5	2.0±0.5	2.0±0.5	2.0±0.5	2.0±0.5	2.0±0.5
	W	9.0+0.3/ -0	9.0+0.3/ -0	9.0±0.3	13.0±0.3	17±0.2	9.4+1.0/ -0.5	9.4+1.0/ -0.5	9.4+1.0/ -0.5	13.5±1.0	16.4+1.0/ -0
Qty.		2000	2000	2000	1000	1000	18000	15000	12000	1000	1000

(Unit: mm)

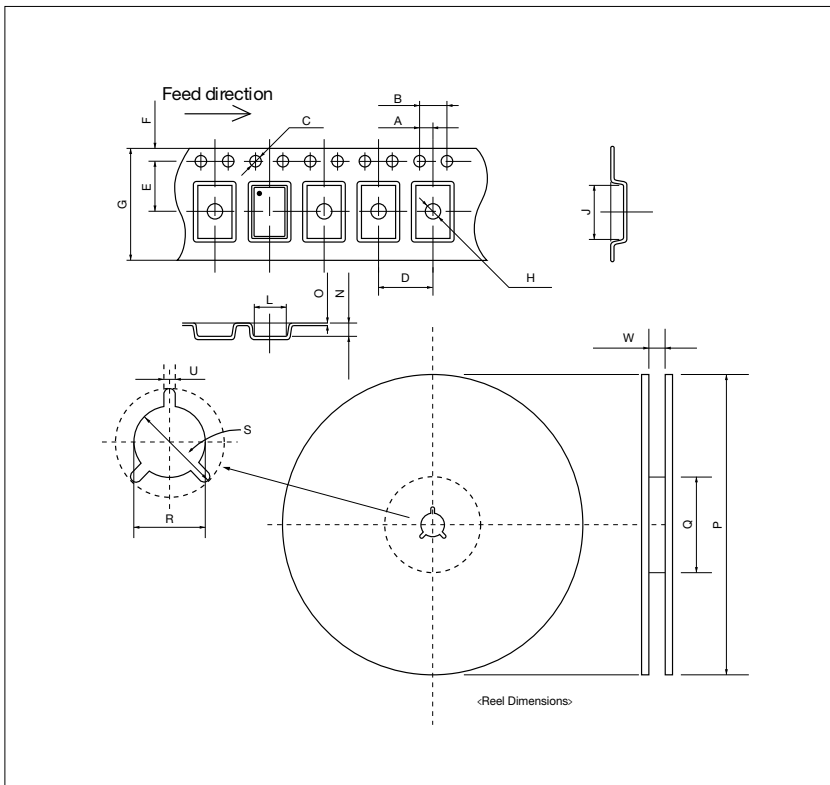

1. Specifications described in this catalog are for references. Products specifications shall be based on written documents agreed by each party.
2. Contents in this catalog are subject to change without notice. It is recommended to confirm the latest information at the time of usage. Also, Kyocera Electronic Components Catalog is revised once a year. We may not be able to accept requests based on old catalogs.
3. Products in this catalog are intended to be used in general electronic equipment such as office equipment, audio and visual equipment, communication equipment, measurement instrument and home appliances. It is absolutely recommended to consult with our sales representatives in advance upon planning to use our products in applications which require extremely high quality and reliability such as aircraft and aerospace equipment, traffic systems, safety systems, power plant and medical equipment including life maintenance systems.
4. Even though we strive for improvements of quality and reliability of products, it is requested to design with enough safety margin in equipment or systems in order not to threaten human lives directly or damage human bodies or properties by an accidental result of products.
5. It is requested to design based on guaranteed specifications for such as maximum ratings, operating voltage and operating temperature. It is not the scope of our guarantee for unsatisfactory results due to misuse or inadequate usage of products in the catalog.
6. Operation summaries and circuit examples in this catalog are intended to explain typical operation and usage of the product. It is recommended to perform circuit and assembly design considering surrounding conditions upon using products in this catalog.
7. Technical information described in this catalog is meant to explain typical operations and applications of products, and it is not intended to guarantee or license intellectual properties or other industrial rights of the third party or Kyocera.
8. Trademarks, logos and brand names used in this catalog are owned by Kyocera or the corresponding third party.
9. Certain products in this catalog are subject to the Foreign Exchange and Foreign Trade Act of Japan, and require the license from Japanese Government upon exporting the restricted products and technical information under the law.
Besides, it is requested not to use products and technical information in the catalog for the development and/or manufacture of weapons of mass destruction or other conventional weapons, nor to provide them to any third party with the possibility of having such purposes.
10. It is prohibited to reprint and reproduce a part or whole of this catalog without permission.
11. Contents described herein are as of October 2022.

