

TAS5825P Evaluation Module

This user's guide describes the operation of the TAS5825P Evaluation Module (EVM). The TAS5825PEVM is a stand-alone EVM. Use the PurePath™ Control Console 3 GUI (PPC3) to initialize and operate this EVM.

Contents

1	Required equipment and accessories.....	1
2	Hardware Overview.....	2
3	Hardware Setup.....	4
4	Board Layouts, Bill of Materials, and Schematic	4

List of Figures

1	TAS5825PEVM	2
2	TAS5825PEVM Schematic (1 of 4)	5
3	TAS5825PEVM Schematic (2 of 4)	6
4	TAS5825PEVM Schematic (3 of 4)	7
5	TAS5825PEVM Schematic (4 of 4)	8
6	TAS5825PEVM Top Overlay	9
7	TAS5825PEVM Bottom Overlay	10

List of Tables

1	Jumpers Configurations.....	4
2	Bill of Materials	11

Trademarks

PurePath is a trademark of Texas Instruments.
 Microsoft, Windows are registered trademarks of Microsoft Corporation.
 All other trademarks are the property of their respective owners.

1 Required equipment and accessories

1. TAS5825PEVM
2. A USB micro type-B cable
3. Power supply unit (PSU)
4. Speakers and cables
5. Desktop or laptop running Microsoft® Windows® 7, Windows 8, Windows 8.1, or Windows 10
6. Audio source: This can be a DVD player with appropriate SPDIF cable, 3.5 mm analog jack or *Playback Media* from Windows 7, Windows 8, Windows 8.1, or Windows 10

2 Hardware Overview

The TAS5825PEVM showcases the latest TI digital input Class-D Closed-Loop amplifier. The TAS5825P is a stereo high-efficiency Closed-Loop audio Class-D audio amplifier with an advanced Hybrid-Pro algorithm to improve system efficiency and reduce heat without clipping distortion. The TAS5825PEVM is a stand-alone EVM, which has optional battery power supply input with LM5155 boost or external power supply input bypassing LM5155 boost (Figure 1), USB control via PurePath Control Console 3 (PPC3) and flexible audio input options.

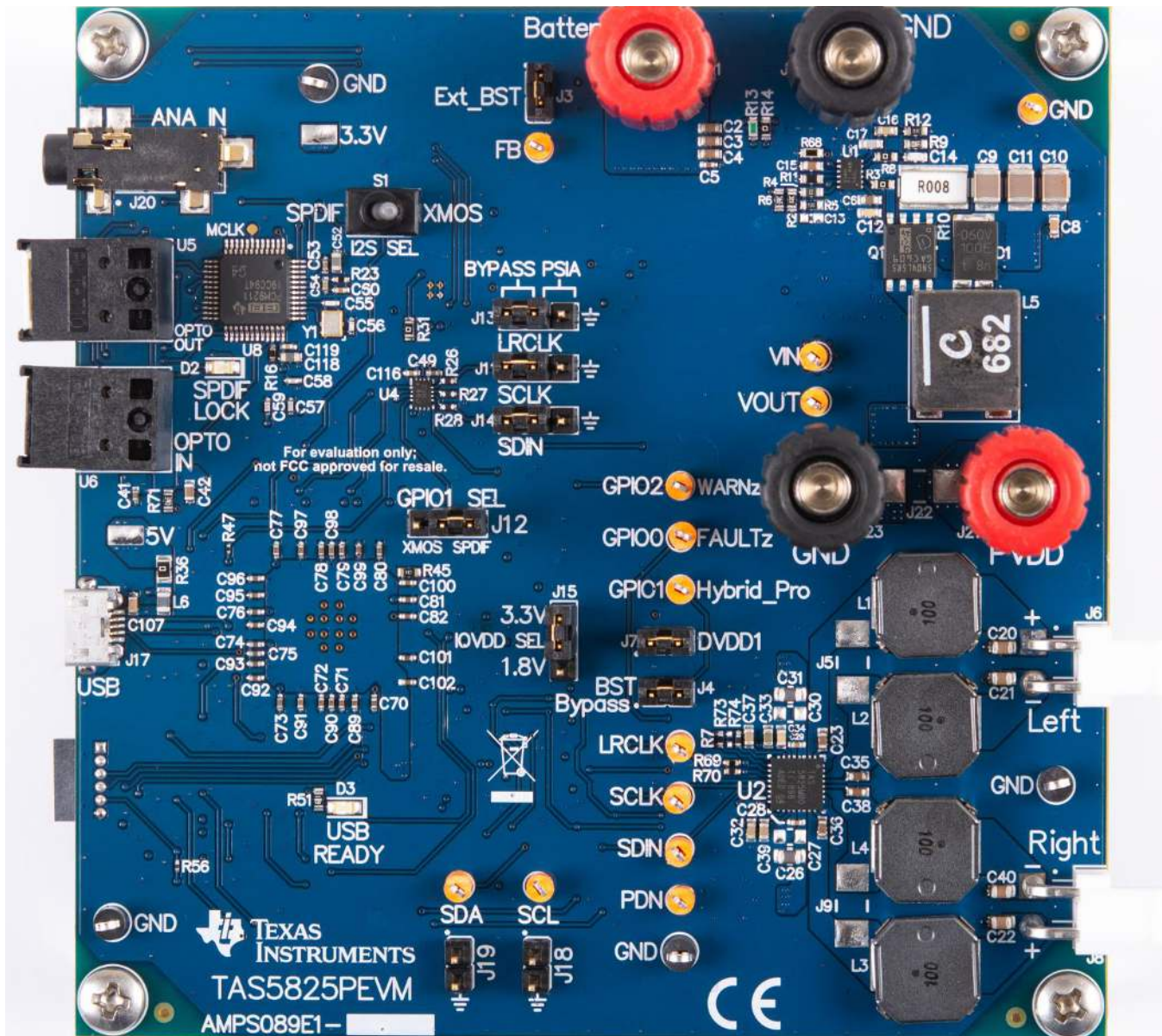

Figure 1. TAS5825PEVM

2.1 Features

The EVM has the following features:

- TAS5825P Hybrid-Pro algorithm for audio envelope tracking
- Integrates LM5155 boost to provide customer system design reference
- Default system configuration: 5V battery input, boost to max 16 V power rail based on audio envelope tracking
- Flexible TAS5825P Hybrid-Pro output (HPFB pin) to customer system board capability
- Demonstration, evaluation and development environment via the PurePath Console 3 software (GUI)

2.2 Functions

The TAS5825PEVM provides USB control via PurePath Control Console 3 (PPC3). The digital audio data input to the TAS5825PEVM is selectable from USB audio, optical SPDIF, PSIA (external I²S) and 3.5 mm analog jack.

2.3 Detailed Operations

The TAS5825PEVM has three different optional audio sources:

1. If XMOS is selected manually by toggling the S1 switch, the Windows Media Player can be used to stream audio.
2. If SPDIF is selected manually by toggling the S1 switch, a DVD player with a optical SPDIF cable can be used to provide audio stream.
3. If external digital audio source such as Programmable Serial Interface Adapter (PSIA) from Audio Precision, jumpers (J13, J11, J14) can be used to insert external I²S signals.

Both 3.3 V and 1.8 V DVDD and IOVDD are supported with TAS5825PEVM. Jumper (J15) can be used to select accordingly based on requirement.

TAS5825PEVM provides optional onboard LM5155 boost Hybrid-Pro evaluation or external customer system boost with Hybrid-Pro feedback (HPFB pin) control:

1. Onboard LM5155 boost Hybrid-Pro evaluation
 - 5 V battery power input through J1 and J2. Bypass external PVDD through DNP J22
 - TAS5825P PVDD is from LM5155 boost output: J10 - IN, J22 - OUT
 - TAS5825P HPFB pin routes to LM5155 FB pin: J3 - IN, J4 - OUT
2. External customer system boost with Hybrid-Pro feedback (HPFB pin) control
 - TAS5825P HPFB pin routes for external customer system boost FB control through TP3 FB and TP13 GND: J3 - OUT, J4 - OUT
 - Customer system boost output for TAS5825P PVDD through J21 PVDD and J23 GND: J10 - OUT, J22 - IN

The USB connection is also used to provide I²C communications with TAS5825P on the EVM. The Pure Path Console 3 (PPC3) is the software tool which can initialize and operate this EVM.

3 Hardware Setup

Use the following steps when setting up the hardware:

- Step 1. Connect speakers to the TAS5825PEVM.
- Step 2. Connect 5V battery input or external PVDD to the TAS5825PEVM.
- Step 3. Plug in a USB cable from the PC to the TAS5825PEVM. The USB READY LED (Blue) is illuminated.
- Step 4. If an optical SPDIF source is used, the blue SPDIF clock-locked LED is illuminated.
- Step 5. Make sure correct jumpers configuration with two modes:

Table 1. Jumpers Configurations

Jumper	Name	LM5155 Boost Mode Configurations	External Customer Boost Mode Configurations
J1, J2	Battery, GND	IN - Battery input	OUT
J21, J23	PVDD, GND	OUT	IN - External PVDD
J10	PVDD_LM5155	IN	OUT
J22	PVDD_EXT	OUT	IN
J4	BST_Bypass	OUT	OUT
J3	Ext_BST	IN	OUT

3.1 I²C Device Addresses

The default I²C addresses on the EVM are set to 0x98 for the only one TAS5825P device.

4 Board Layouts, Bill of Materials, and Schematic

This section includes the EVM schematics, board layouts and bill of materials.

4.1 Schematics

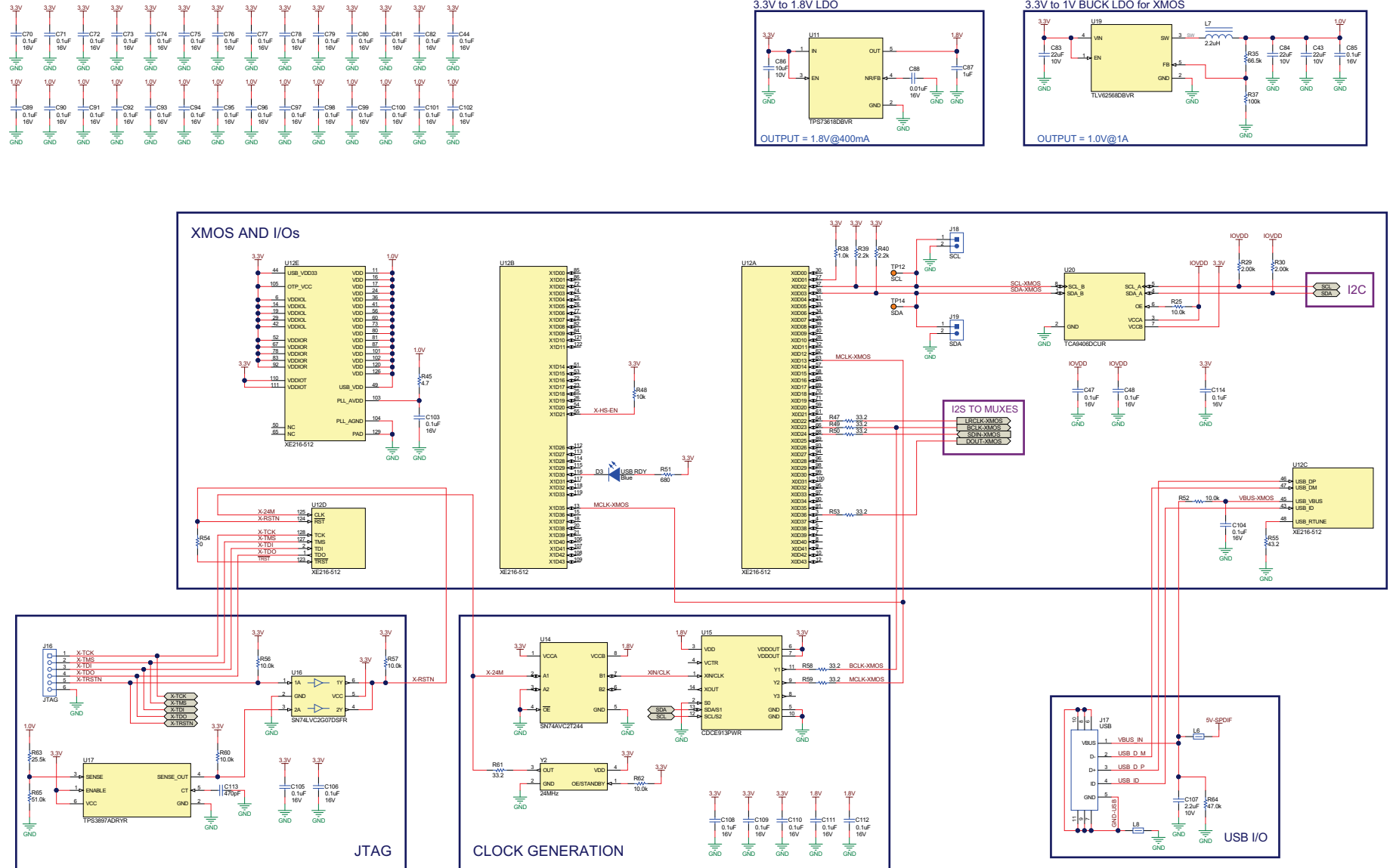

Figure 2. TAS5825PEVM Schematic (1 of 4)

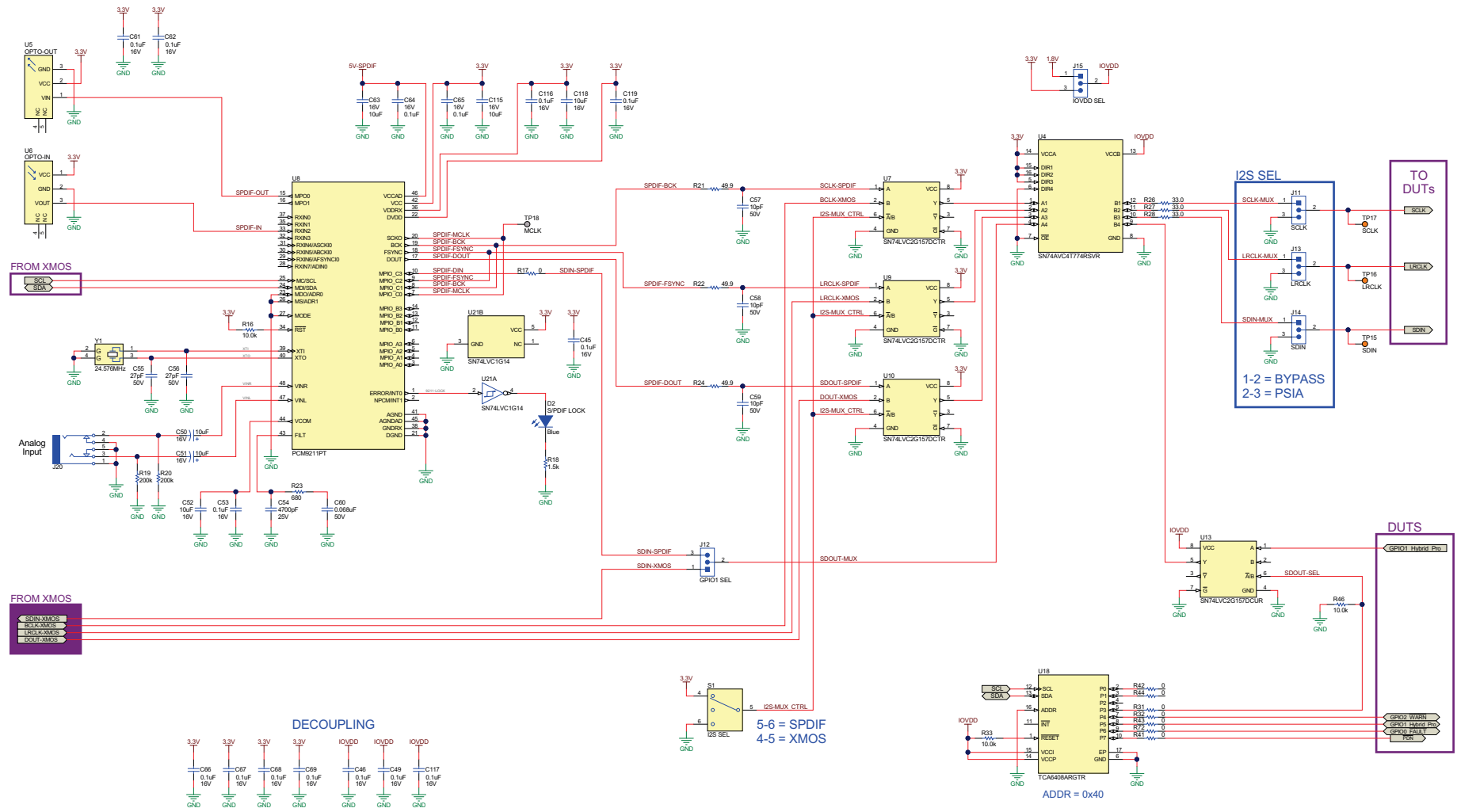

Figure 3. TAS5825PEVM Schematic (2 of 4)

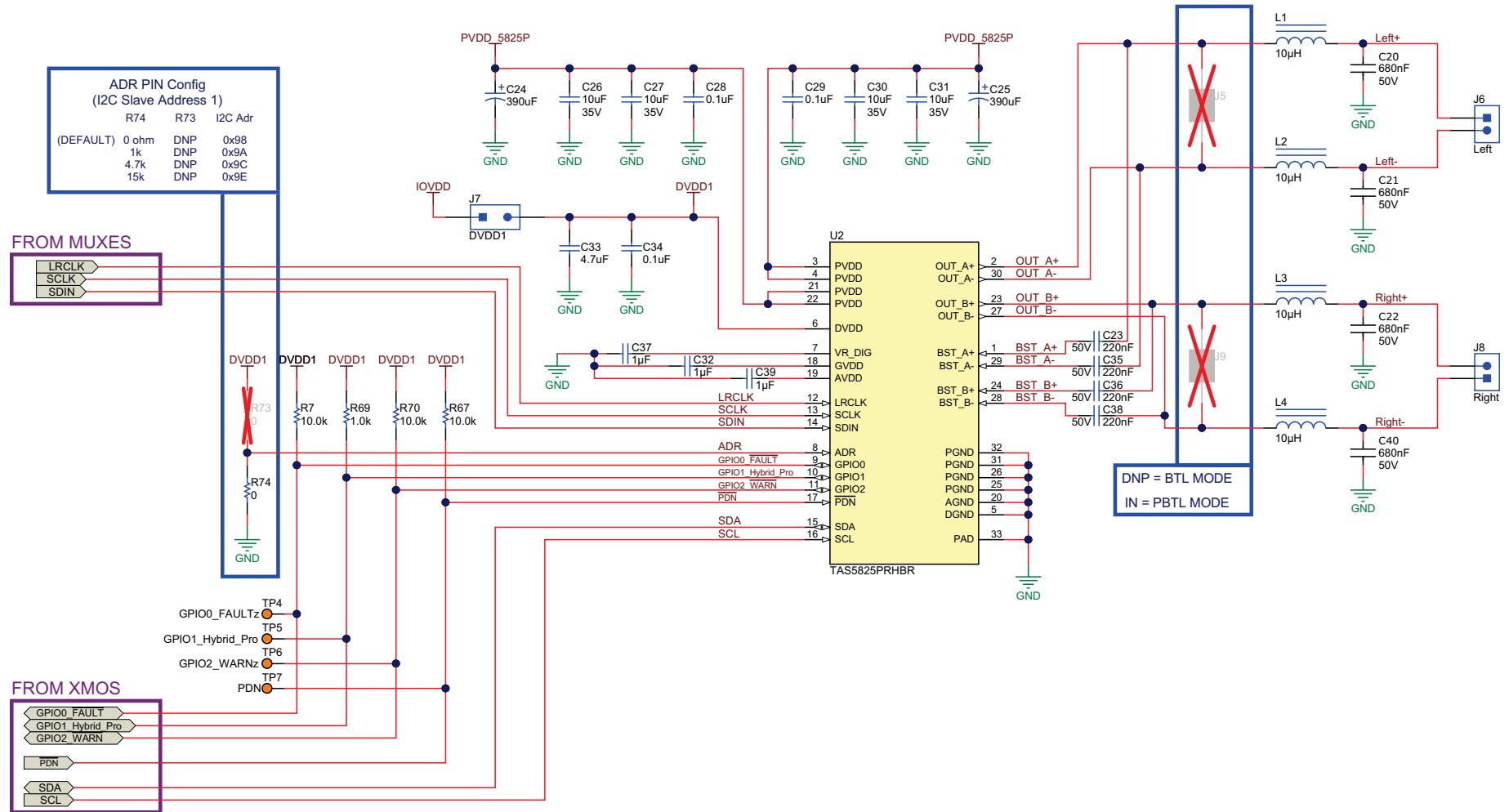

Figure 4. TAS5825PEVM Schematic (3 of 4)

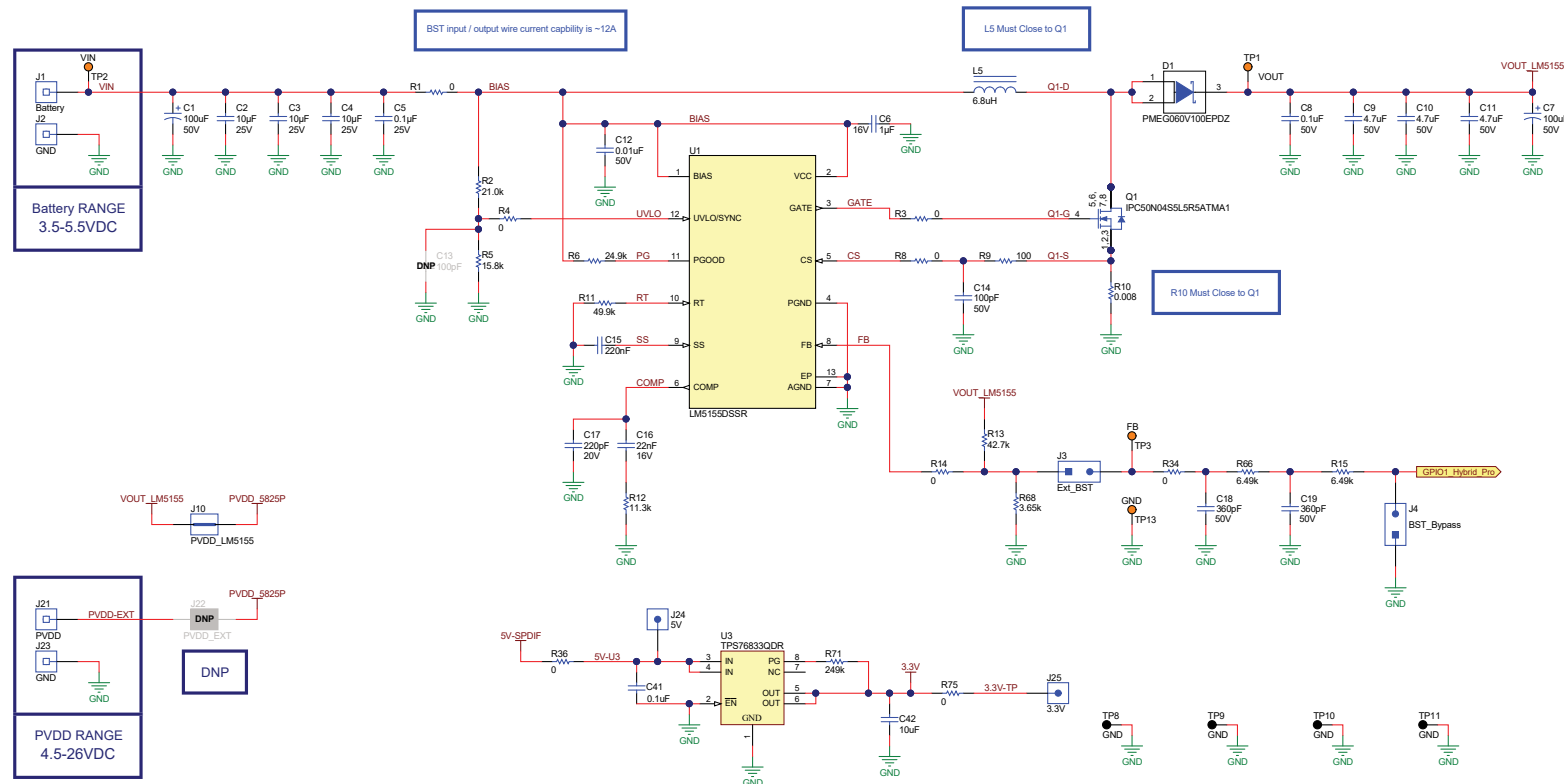

Figure 5. TAS5825PEVM Schematic (4 of 4)

4.2 Board Layouts

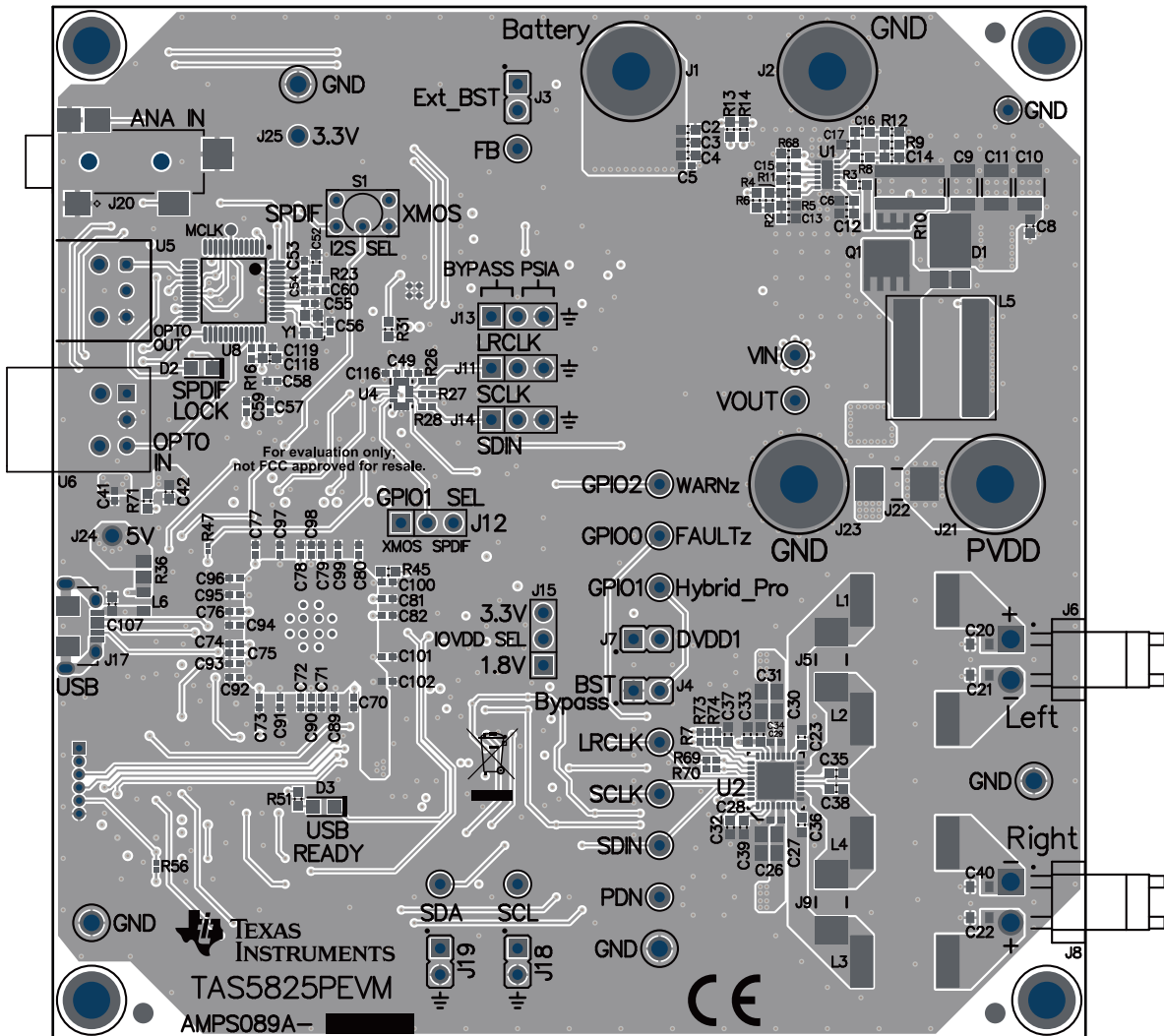

Figure 6. TAS5825PEVM Top Overlay

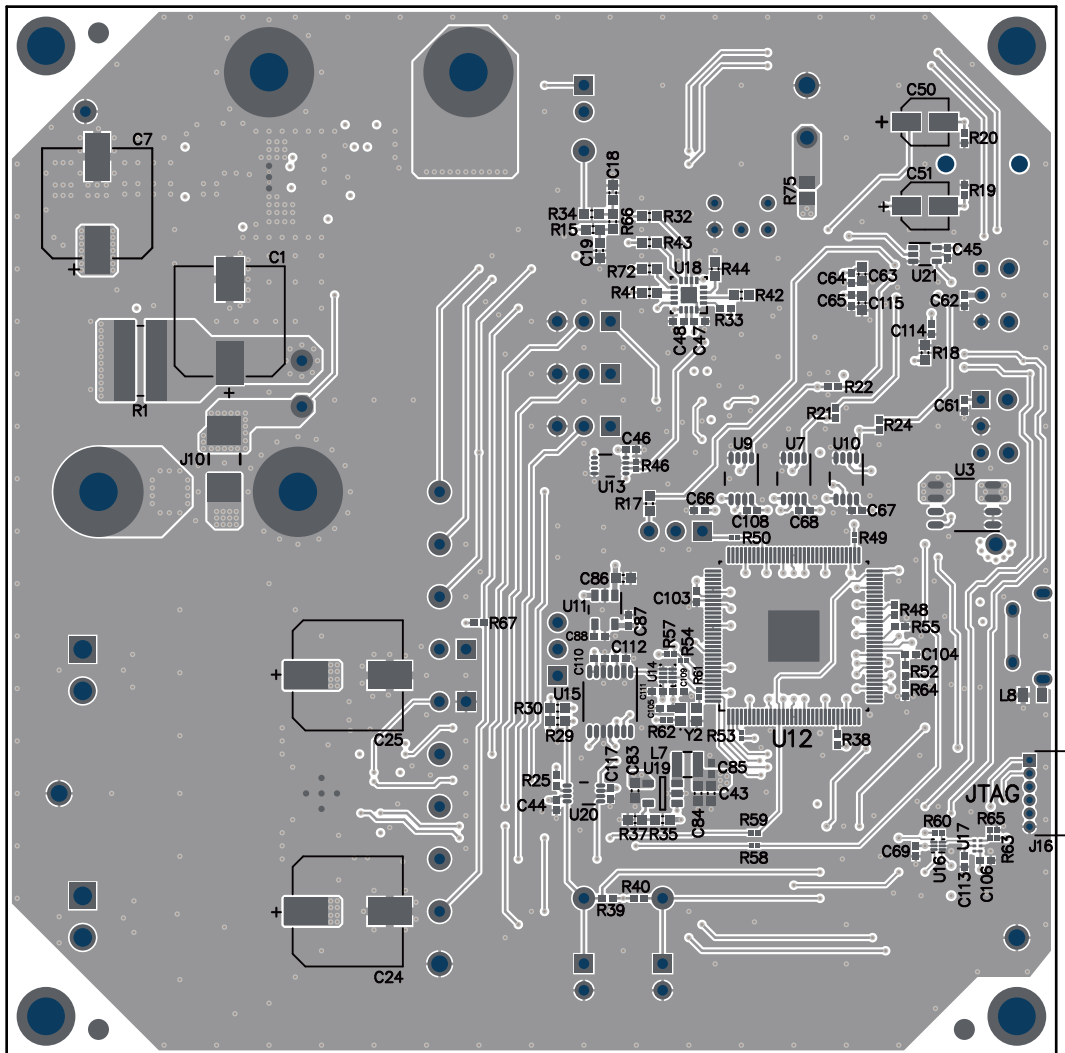

Figure 7. TAS5825PEVM Bottom Overlay

4.3 Bill of Materials

Table 2 details the EVM BOM.

Table 2. Bill of Materials⁽¹⁾

Designator	Qty	Value	Description	Package Reference	Part Number	Manufacturer	Alternate Part Number ⁽¹⁾	Alternate Manufacturer
C1	1	100uF	CAP, Polymer Hybrid, 100 uF, 50 V, +/- 20%, 28 ohm, 10x10 SMD	10x10	EEHZC1H101P	Panasonic		
C2, C3, C4	3	10uF	CAP, CERM, 10 µF, 25 V,+/- 10%, X5R, 0603	0603	GRM188R61E106KA73D	MuRata		
C5	1	0.1uF	CAP, CERM, 0.1 µF, 25 V,+/- 10%, X7R, AEC-Q200 Grade 1, 0402	0402	CGA2B3X7R1E104K050BB	TDK		
C6	1	1uF	CAP, CERM, 1 uF, 16 V, +/- 20%, X7R, AEC-Q200 Grade 1, 0603	0603	GCM188R71C105MA64D	MuRata		
C7	1	100uF	CAP, Aluminum Polymer, 100 uF, 50 V, +/- 20%, 0.025 ohm, AEC-Q200 Grade 2, D10xL10mm SMD	D10xL10mm	HHXB500ARA101MJA0G	Chemi-Con		
C8	1	0.1uF	CAP, CERM, 0.1 uF, 50 V, +/- 10%, X7R, AEC-Q200 Grade 1, 0603	0603	CGA3E2X7R1H104K080AA	TDK		
C9, C10, C11	3	4.7uF	CAP, CERM, 4.7 uF, 50 V, +/- 10%, X7R, AEC-Q200 Grade 1, 1210	1210	CGA6P3X7R1H475K250AB	TDK		
C12	1	0.01uF	CAP, CERM, 0.01 uF, 50 V, +/- 10%, X7R, 0603	0603	CL10B103KB8NCNC	Samsung Electro-Mechanics		
C14	1	100pF	CAP, CERM, 100 pF, 50 V,+/- 1%, C0G/NP0, 0603	0603	C0603C101F5GACTU	Kemet		
C15	1	0.22uF	CAP, CERM, 0.22 uF, 50 V, +/- 10%, X7R, AEC-Q200 Grade 1, 0603	0603	CGA3E3X7R1H224K080AB	TDK		
C16	1	0.022uF	CAP, CERM, 0.022 uF, 16 V, +/- 10%, X7R, 0603	0603	C0603C223K4RACTU	Kemet		
C17	1	220pF	CAP, CERM, 220 pF, 20 V, +/- 5%, C0G/NP0, AEC-Q200 Grade 1, 0603	0603	CGA3E2C0G1H221J080AA	TDK		
C18, C19	2	360pF	CAP, CERM, 360 pF, 50 V, +/- 5%, C0G/NP0, 0603	0603	GRM1885C1H361JA01D	MuRata		
C20, C21, C22, C40	4		CAP CER 0.68UF 50V X7R 0805	0805	CGA4J3X7R1H684M125AB	TDK Corporation		
C23, C35, C36, C38	4	0.22uF	CAP, CERM, 0.22 uF, 50 V, +/- 10%, X7R, AEC-Q200 Grade 1, 0603	0603	GCM188R71H224KA64D	MuRata		
C24, C25	2	390uF	CAP, AL, 390 uF, 35 V, +/- 20%, 0.08 ohm, SMD	10x10	UCL1V391MNL1GS	Nichicon		
C26, C27, C30, C31	4	10uF	CAP, CERM, 10 uF, 35 V, +/- 10%, X5R, 0805	0805	C2012X5R1V106K085AC	TDK		
C28, C29	2	0.1uF	CAP, CERM, 0.1 uF, 50 V, +/- 10%, X7R, AEC-Q200 Grade 1, 0402	0402	CGA2B3X7R1H104K050BB	TDK		
C32, C37, C39	3	1uF	CAP, CERM, 1 µF, 16 V,+/- 20%, X7R, 0603	0603	CL10B105MO8NNWC	Samsung		
C33	1	4.7uF	CAP, CERM, 4.7 uF, 10 V, +/- 10%, X5R, 0603	0603	C0603C475K8PACTU	Kemet		
C34	1	0.1uF	CAP, CERM, 0.1 uF, 16 V, +/- 10%, X7R, 0603	0603	C0603C104K4RACTU	Kemet		

⁽¹⁾ Unless otherwise noted in the *Alternate Part Number* or *Alternate Manufacturer* columns, all parts may be substituted with equivalents.

Table 2. Bill of Materials⁽¹⁾ (continued)

Designator	Qty	Value	Description	Package Reference	Part Number	Manufacturer	Alternate Part Number ⁽¹⁾	Alternate Manufacturer
C41, C44, C45, C46, C47, C48, C49, C53, C61, C62, C64, C65, C66, C67, C68, C69, C70, C71, C72, C73, C74, C75, C76, C77, C78, C79, C80, C81, C82, C85, C89, C90, C91, C92, C93, C94, C95, C96, C97, C98, C99, C100, C101, C102, C103, C104, C105, C106, C108, C109, C110, C111, C112, C114, C116, C117, C119	57	0.1uF	CAP, CERM, 0.1 uF, 16 V, +/- 10%, X7R, 0402	0402	885012205037	Würth Elektronik		
C42, C86	2	10uF	CAP, CERM, 10 uF, 10 V, +/- 20%, X5R, 0603	0603	C1608X5R1A106M080AC	TDK		
C43, C83, C84	3	22uF	CAP, CERM, 22 uF, 10 V, +/- 20%, X5R, 0603	0603	C1608X5R1A226M080AC	TDK		
C50, C51	2	10uF	CAP, AL, 10 uF, 16 V, +/- 20%, SMD	D55	EMVE160ADA100MD55G	Chemi-Con		
C52, C63, C115, C118	4	10uF	CAP, CERM, 10 uF, 16 V, +/- 20%, X5R, 0603	0603	EMK107BBJ106MA-T	Taiyo Yuden		
C54	1	4700pF	CAP, CERM, 4700 pF, 25 V, +/- 10%, X7R, 0402	0402	CC0402KRX7R8BB472	Yageo		
C55, C56	2	27pF	CAP, CERM, 27 pF, 50 V, +/- 5%, C0G/NP0, 0402	0402	GJM1555C1H270JB01	MuRata		
C57, C58, C59	3	10pF	CAP, CERM, 10 pF, 50 V, +/- 5%, C0G/NP0, 0402	0402	885012005055	Würth Elektronik		
C60	1	0.068uF	CAP, CERM, 0.068 uF, 50 V, +/- 10%, X7R, AEC-Q200 Grade 1, 0402	0402	CGA2B3X7R1H683K050BB	TDK		
C87	1	1uF	CAP, CERM, 1 uF, 6.3 V, +/- 20%, X5R, 0402	0402	GRM152R60J105ME15D	MuRata		
C88	1	0.01uF	CAP, CERM, 0.01 uF, 16 V, +/- 10%, X7R, 0402	0402	885012205031	Würth Elektronik		
C107	1	2.2uF	CAP, CERM, 2.2 uF, 10 V, +/- 10%, X7R, 0603	0603	GRM188R71A225KE15D	MuRata		
C113	1	470pF	CAP, CERM, 470 pF, 50 V, +/- 5%, C0G/NP0, 0402	0402	GRM1555C1H471JA01D	MuRata		
D1	1	60V	Diode, Schottky, 60 V, 10 A, AEC-Q101, CFP15	CFP15	PMEG060V100EPDZ	Nexperia		
D2, D3	2	Blue	LED, Blue, SMD	LED_0805	LTST-C170TBKT	Lite-On		
H1, H2, H3, H4	4		MACHINE SCREW PAN PHILLIPS M3	M3 Screw	RM3X8MM 2701	APM HEXSEAL		
H5, H6, H7, H8	4		Standoff, Hex, 12mm, M3, Aluminum	Aluminum M3 12mm Hex Standoff	24434	Keystone		
J1, J21	2		Binding Post, RED, TH	11.4x27.2mm	7006	Keystone		
J2, J23	2		Binding Post, BLACK, TH	11.4x27.2mm	7007	Keystone		
J3, J4, J7, J18, J19	5		Header, 100mil, 2x1, Gold, TH	Sullins 100mil, 1x2, 230 mil above insulator	PBC02SAAN	Sullins Connector Solutions		
J6, J8	2		Header (friction lock), 3.96mm, 2x1, Tin, R/A, TH	Header, 2x1, 3.96mm, R/A	B2PS-VH(LF)(SN)	JST Manufacturing		
J10	1		JUMPER TIN SMD	6.85x0.97x2.51 mm	S1911-46R	Harwin		

Table 2. Bill of Materials⁽¹⁾ (continued)

Designator	Qty	Value	Description	Package Reference	Part Number	Manufacturer	Alternate Part Number ⁽¹⁾	Alternate Manufacturer
J11, J12, J13, J14, J15	5		Header, 100mil, 3x1, Gold, TH	PBC03SAAN	PBC03SAAN	Sullins Connector Solutions		
J16	1		Receptacle, 50mil, 6x1, Gold, R/A, TH	6x1 Receptacle	LPPB061NGCN-RC	Sullins Connector Solutions		
J17	1		Connector, Receptacle, Micro-USB Type AB, R/A, Bottom Mount SMT	Connector, USB Micro AB	DX4R205JJAR1800	JAE Electronics		
J20	1		Audio Jack, 3.5mm, Stereo, R/A, SMT	Phone Jack, 6x5x17mm	35RASMT4BHNRX	Switchcraft		
J24, J25	2			Test point, TH Slot Test point	1040	Keystone		
L1, L2, L3, L4	4	10uH	Inductor, Shielded, Ferrite, 10 µH, 4.4 A, 0.0304 ohm, SMD		1274AS-H-100M=P3	MuRata		
L5	1	6.8uH	Inductor, Shielded, Composite, 6.8 uH, 18.5 A, 0.01 ohm, SMD	Inductor, 11.3x10x10mm	XAL1010-682MEB	Coilcraft		
L6, L8	2	600 ohm	Ferrite Bead, 600 ohm @ 100 MHz, 2 A, 0805	0805	MPZ2012S601AT000	TDK		
L7	1	2.2uH	Inductor, Multilayer, Ferrite, 2.2 uH, 1.3 A, 0.08 ohm, SMD	SMD, Body 2.5x2mm, Height 1.2mm	LQM2HPN2R2MG0L	MuRata		
Q1	1	40V	MOSFET, N-CH, 40 V, 50 A, AEC-Q101, SON-8	SON-8	IPC50N04S5L5R5ATMA1	Infineon Technologies		
R1	1	0	RES, 0, 5%, 2 W, 2512 WIDE	2512 WIDE	RCL1225000Z0EG	Vishay Draloric		
R2	1	21.0k	RES, 21.0 k, 1%, 0.1 W, AEC-Q200 Grade 0, 0603	0603	CRCW060321K0FKEA	Vishay-Dale		
R3, R8, R14, R31, R32, R34, R41, R42, R43, R44, R72	12	0	RES, 0, 5%, 0.1 W, 0603	0603	RC0603JR-070RL	Yageo		
R4, R17	2	0	RES, 0, 1%, 0.1 W, AEC-Q200 Grade 0, 0603	0603	RMCF0603ZT0R00	Stackpole Electronics Inc		
R5	1	15.8k	RES, 15.8 k, 1%, 0.1 W, AEC-Q200 Grade 0, 0603	0603	CRCW060315K8FKEA	Vishay-Dale		
R6	1	24.9k	RES, 24.9 k, 1%, 0.1 W, 0603	0603	RC0603FR-0724K9L	Yageo		
R7	1	15.0k	RES, 15.0 k, .1%, .063 W, AEC-Q200 Grade 0, 0402	0402	ERA-2AEB153X	Panasonic		
R9	1	100	RES, 100, 1%, 0.1 W, 0603	0603	RC0603FR-07100RL	Yageo		
R10	1	0.008	RES, 0.008, 1%, 3 W, AEC-Q200 Grade 0, 2512 WIDE	2512 WIDE	KRL6432E-M-R008-F-T1	Susumu Co Ltd		
R11	1	49.9k	RES, 49.9 k, 1%, 0.1 W, AEC-Q200 Grade 0, 0603	0603	CRCW060349K9FKEA	Vishay-Dale		
R12	1	11.3k	RES, 11.3 k, 1%, 0.1 W, AEC-Q200 Grade 0, 0603	0603	CRCW060311K3FKEA	Vishay-Dale		
R13	1	42.7k	RES, 42.7 k, 0.5%, 0.1 W, 0603	0603	RT0603DRE0742K7L	Yageo America		
R15, R66	2	6.49k	RES, 6.49 k, 0.1%, 0.1 W, AEC-Q200 Grade 0, 0603	0603	ERA-3AEB6491V	Panasonic		
R16, R33, R67, R70	4	10.0k	RES, 10.0 k, 1%, 0.063 W, AEC-Q200 Grade 0, 0402	0402	CRCW040210K0FKED	Vishay-Dale		
R18	1	1.5k	RES, 1.5 k, 5%, 0.1 W, AEC-Q200 Grade 0, 0603	0603	CRCW06031K50JNEA	Vishay-Dale		
R19, R20	2	200k	RES, 200 k, 5%, 0.063 W, AEC-Q200 Grade 0, 0402	0402	CRCW0402200KJNED	Vishay-Dale		
R21, R22, R24	3	49.9	RES, 49.9, 1%, 0.063 W, AEC-Q200 Grade 0, 0402	0402	CRCW040249R9FKED	Vishay-Dale		
R23	1	680	RES, 680, 5%, 0.063 W, AEC-Q200 Grade 0, 0402	0402	CRCW0402680RJNED	Vishay-Dale		
R25, R52	2	10.0k	RES, 10.0 k, 1%, 0.1 W, 0402	0402	ERJ-2RKF1002X	Panasonic		
R26, R27, R28	3	33.0	RES, 33.0, 1%, 0.1 W, 0402	0402	ERJ-2RKF33R0X	Panasonic		
R29, R30	2	2.00k	RES, 2.00 k, 1%, 0.1 W, AEC-Q200 Grade 0, 0603	0603	ERJ3EKF2001V	Panasonic		
R35	1	66.5k	RES, 66.5 k, 1%, 0.1 W, 0603	0603	RC0603FR-0766K5L	Yageo		
R36, R75	2	0	RES, 0, 5%, 0.125 W, 0805	0805	RC0805JR-070RL	Yageo America		

Table 2. Bill of Materials⁽¹⁾ (continued)

Designator	Qty	Value	Description	Package Reference	Part Number	Manufacturer	Alternate Part Number ⁽¹⁾	Alternate Manufacturer
R37	1	100k	RES, 100 k, 1%, 0.1 W, 0603	0603	RC0603FR-07100KL	Yageo		
R38, R69	2	1.0k	RES, 1.0 k, 5%, 0.063 W, AEC-Q200 Grade 0, 0402	0402	CRCW04021K00JNED	Vishay-Dale		
R39, R40	2	2.2k	RES, 2.2 k, 5%, 0.063 W, AEC-Q200 Grade 0, 0402	0402	CRCW04022K20JNED	Vishay-Dale		
R45	1	4.7	RES, 4.7, 5%, 0.1 W, AEC-Q200 Grade 0, 0603	0603	CRCW06034R70JNEA	Vishay-Dale		
R46, R56, R57, R60, R62	5	10.0k	RES, 10.0 k, 1%, 0.05 W, 0201	0201	CRCW020110K0FKED	Vishay-Dale		
R47, R49, R50, R53, R58, R59, R61	7	33.2	RES, 33.2, 1%, 0.05 W, 0201	0201	RC0201FR-0733R2L	Yageo America		
R51	1	680	RES, 680, 1%, 0.1 W, 0603	0603	RC0603FR-07680RL	Yageo		
R54	1	0	RES, 0, 5%, 0.05 W, AEC-Q200 Grade 1, 0201	0201	ERJ-1GE0R00C	Panasonic		
R55	1	43.2	RES, 43.2, 1%, 0.1 W, AEC-Q200 Grade 0, 0402	0402	ERJ2RKF43R2X	Panasonic		
R63	1	25.5k	RES, 25.5 k, 1%, 0.05 W, 0201	0201	RC0201FR-0725K5L	Yageo America		
R64	1	47.0k	RES, 47.0 k, 1%, 0.0625 W, 0402	0402	RC0402FR-0747KL	Yageo America		
R65	1	51.0k	RES, 51.0 k, 1%, 0.05 W, 0201	0201	RC0201FR-0751KL	Yageo America		
R68	1	3.65k	RES, 3.65 k, 0.1%, 0.1 W, 0603	0603	RG1608P-3651-B-T5	Susumu Co Ltd		
R71	1	249k	RES, 249 k, 1%, 0.1 W, 0603	0603	RC0603FR-07249KL	Yageo		
R74	1	0	RES, 0, 5%, 0.1 W, AEC-Q200 Grade 0, 0402	0402	ERJ-2GE0R00X	Panasonic		
S1	1		Switch, Toggle, SPDT 1Pos, TH	7 X 11 X4.5 mm	G12AP	NKK Switches		
SH-J1, SH-J2, SH-J3, SH-J4, SH-J5, SH-J6, SH-J7, SH-J8	8	1x2	Shunt, 100mil, Gold plated, Black	Shunt	SNT-100-BK-G	Samtec	969102-0000-DA	3M
TP1, TP2, TP3, TP4, TP5, TP6, TP7, TP12, TP13, TP14, TP15, TP16, TP17	13		Test Point, Miniature, Orange, TH	Orange Miniature Testpoint	5003	Keystone		
TP8, TP9, TP10, TP11	4		Test Point, Compact, Black, TH	Black Compact Testpoint	5006	Keystone		
U1	1		2.2-MHz Wide Input Nonsynchronous Boost, Sepic, Flyback Controller, DSS0012B (WSON-12)	DSS0012B	LM5155DSSR	Texas Instruments	LM5155DSST	Texas Instruments
U2	1		4.5V to 26.4V, 38W Stereo, Digital Input, High Efficiency Closed-Loop Class-D Audio Amplifier with Hybrid-Pro Algorithm, RHB0032E (UQFN-32)	RHB0032E	TAS5825PRHBR	Texas Instruments		Texas Instruments
U3	1		Single Output Fast Transient Response LDO, 1 A, Fixed 3.3 V Output, 2.7 to 10 V Input, with Low IQ, 8-pin SOIC (D), -40 to 125 degC, Green (RoHS & no Sb/Br)	D0008A	TPS76833QDR	Texas Instruments		
U4	1		4-Bit Dual-Supply Bus Transceiver With Configurable Voltage-Level Shifting and 3-State Outputs, RSV0016A (UQFN-16)	RSV0016A	SN74AVC4T774RSVR	Texas Instruments		Texas Instruments
U5	1		Fiber Optic Transmitter, TH	9.7x13.5mm	EAPLTA4	Everlight		
U6	1		Photolink- Fiber Optic Receiver, TH	13.5x10x9.7mm	PLR135/T10	Everlight		
U7, U9, U10	3		Single 2-Line to 1-Line Data Selector/Multiplexer, DCT0008A,, LARGE T&R	DCT0008A	SN74LVC2G157DCTR	Texas Instruments	SN74LVC2G157DCUT	Texas Instruments

Table 2. Bill of Materials⁽¹⁾ (continued)

Designator	Qty	Value	Description	Package Reference	Part Number	Manufacturer	Alternate Part Number ⁽¹⁾	Alternate Manufacturer
U8	1		216 kHz Digital Audio Interface Transceiver (DIX) with Stereo ADC and Routing, PCM, S / PDIF, ADC, 4.5 - 5.5V for Analog, 2.9 - 3.6V for DIX, -40 to 85 degC, 48-Pin LQFP (PT), Green (RoHS & no Sb/Br)	PT0048A	PCM9211PT	Texas Instruments		
U11	1		Single Output LDO, 400mA, Adj.(1.2 to 5.5V), Cap free, Low Noise, Reverse Current Protection, DBV0005A (SOT-23-5)	DBV0005A	TPS73618DBVR	Texas Instruments		
U12	1		IC MCU 512KB RAM, 128TQFP	TQFP-128	XEF216-512-TQ128-C20	XMOS semiconductor		
U13	1		Single 2-Line to 1-Line Data Selector/Multiplexer, DCU0008A, LARGE T&R	DCU0008A	SN74LVC2G157DCUR	Texas Instruments	SN74LVC2G157DCUT	Texas Instruments
U14	1		Dual-Bit Dual-Supply Bus Transceiver, DQM0008A (X2SON-8)	DQM0008A	SN74AVC2T244DQMR	Texas Instruments		
U15	1		Programmable 1-PLL VCXO Clock Synthesizer with 2.5-V or 3.3-V LVCMOS Outputs, PW0014A (TSSOP-14)	PW0014A	CDCE913PWR	Texas Instruments	CDCE913PW	Texas Instruments
U16	1		Enhanced Product Dual Buffer/Driver with Open-Drain Output, DCK0006A (SOT-SC70-6)	DSF0006A	SN74LVC2G07DSFR	Texas Instruments		
U17	1		Single-Channel Ultra-Small Adjustable Supervisory Circuit With Active-High Open-Drain Output, DRY0006A (USON-6)	DRY0006A	TPS3897ADRYR	Texas Instruments		
U18	1		Low-Voltage 8-Bit I2C and SMBus I/O Expander, 1.65 to 5.5 V, -40 to 85 degC, 16-pin QFN (RGT), Green (RoHS & no Sb/Br)	RGT0016A	TCA6408ARGTR	Texas Instruments		
U19	1		1-A High Efficiency Step-Down Converter in SOT23-5 Package, DBV005A, DBV0005A (SOT-5)	DBV0005A	TLV62568DBVR	Texas Instruments	TLV62568DBVT	Texas Instruments
U20	1		2-Bit Bidirectional 1-MHz I2C Bus and SMBus Voltage-Level Shifter, DCU0008A (VSSOP-8)	DCU0008A	TCA9406DCUR	Texas Instruments		
U21	1		Single Schmitt-Trigger Inverter, DCK0005A (SOT-SC70-5)	DCK0005A	SN74LVC1G14DCKR	Texas Instruments	SN74LVC1G14DCKT	Texas Instruments
Y1	1		Crystal, 24.576 MHz, 10pF, SMD	2.5x0.5x2.0mm	ABM10-24.576MHZ-E20-T	Abracon Corporation		
Y2	1		OSC, 24 MHz, 2.25 - 3.63 V, SMD	2x1.6mm	ASTMLPA-24.000MHZ-EJ-E-T	Abracon Corporation		
C13	0	100pF	CAP, CERM, 100 pF, 50 V,+/- 1%, COG/NP0, 0603	0603	C0603C101F5GACTU	Kemet		
FID1, FID2, FID3, FID4, FID5, FID6	0		Fiducial mark. There is nothing to buy or mount.	N/A	N/A	N/A		
J5, J9, J22	0		JUMPER TIN SMD	6.85x0.97x2.51 mm	S1911-46R	Harwin		
R73	0	0	RES, 0, 5%, 0.1 W, AEC-Q200 Grade 0, 0402	0402	ERJ-2GE0R00X	Panasonic		

STANDARD TERMS FOR EVALUATION MODULES

1. *Delivery:* TI delivers TI evaluation boards, kits, or modules, including any accompanying demonstration software, components, and/or documentation which may be provided together or separately (collectively, an "EVM" or "EVMs") to the User ("User") in accordance with the terms set forth herein. User's acceptance of the EVM is expressly subject to the following terms.
 - 1.1 EVMs are intended solely for product or software developers for use in a research and development setting to facilitate feasibility evaluation, experimentation, or scientific analysis of TI semiconductors products. EVMs have no direct function and are not finished products. EVMs shall not be directly or indirectly assembled as a part or subassembly in any finished product. For clarification, any software or software tools provided with the EVM ("Software") shall not be subject to the terms and conditions set forth herein but rather shall be subject to the applicable terms that accompany such Software
 - 1.2 EVMs are not intended for consumer or household use. EVMs may not be sold, sublicensed, leased, rented, loaned, assigned, or otherwise distributed for commercial purposes by Users, in whole or in part, or used in any finished product or production system.
2. *Limited Warranty and Related Remedies/Disclaimers:*
 - 2.1 These terms do not apply to Software. The warranty, if any, for Software is covered in the applicable Software License Agreement.
 - 2.2 TI warrants that the TI EVM will conform to TI's published specifications for ninety (90) days after the date TI delivers such EVM to User. Notwithstanding the foregoing, TI shall not be liable for a nonconforming EVM if (a) the nonconformity was caused by neglect, misuse or mistreatment by an entity other than TI, including improper installation or testing, or for any EVMs that have been altered or modified in any way by an entity other than TI, (b) the nonconformity resulted from User's design, specifications or instructions for such EVMs or improper system design, or (c) User has not paid on time. Testing and other quality control techniques are used to the extent TI deems necessary. TI does not test all parameters of each EVM. User's claims against TI under this Section 2 are void if User fails to notify TI of any apparent defects in the EVMs within ten (10) business days after delivery, or of any hidden defects with ten (10) business days after the defect has been detected.
 - 2.3 TI's sole liability shall be at its option to repair or replace EVMs that fail to conform to the warranty set forth above, or credit User's account for such EVM. TI's liability under this warranty shall be limited to EVMs that are returned during the warranty period to the address designated by TI and that are determined by TI not to conform to such warranty. If TI elects to repair or replace such EVM, TI shall have a reasonable time to repair such EVM or provide replacements. Repaired EVMs shall be warranted for the remainder of the original warranty period. Replaced EVMs shall be warranted for a new full ninety (90) day warranty period.

WARNING

Evaluation Kits are intended solely for use by technically qualified, professional electronics experts who are familiar with the dangers and application risks associated with handling electrical mechanical components, systems, and subsystems.

User shall operate the Evaluation Kit within TI's recommended guidelines and any applicable legal or environmental requirements as well as reasonable and customary safeguards. Failure to set up and/or operate the Evaluation Kit within TI's recommended guidelines may result in personal injury or death or property damage. Proper set up entails following TI's instructions for electrical ratings of interface circuits such as input, output and electrical loads.

NOTE:

EXPOSURE TO ELECTROSTATIC DISCHARGE (ESD) MAY CAUSE DEGRADATION OR FAILURE OF THE EVALUATION KIT; TI RECOMMENDS STORAGE OF THE EVALUATION KIT IN A PROTECTIVE ESD BAG.

3 Regulatory Notices:

3.1 United States

3.1.1 Notice applicable to EVMs not FCC-Approved:

FCC NOTICE: This kit is designed to allow product developers to evaluate electronic components, circuitry, or software associated with the kit to determine whether to incorporate such items in a finished product and software developers to write software applications for use with the end product. This kit is not a finished product and when assembled may not be resold or otherwise marketed unless all required FCC equipment authorizations are first obtained. Operation is subject to the condition that this product not cause harmful interference to licensed radio stations and that this product accept harmful interference. Unless the assembled kit is designed to operate under part 15, part 18 or part 95 of this chapter, the operator of the kit must operate under the authority of an FCC license holder or must secure an experimental authorization under part 5 of this chapter.

3.1.2 For EVMs annotated as FCC – FEDERAL COMMUNICATIONS COMMISSION Part 15 Compliant:

CAUTION

This device complies with part 15 of the FCC Rules. Operation is subject to the following two conditions: (1) This device may not cause harmful interference, and (2) this device must accept any interference received, including interference that may cause undesired operation.

Changes or modifications not expressly approved by the party responsible for compliance could void the user's authority to operate the equipment.

FCC Interference Statement for Class A EVM devices

NOTE: This equipment has been tested and found to comply with the limits for a Class A digital device, pursuant to part 15 of the FCC Rules. These limits are designed to provide reasonable protection against harmful interference when the equipment is operated in a commercial environment. This equipment generates, uses, and can radiate radio frequency energy and, if not installed and used in accordance with the instruction manual, may cause harmful interference to radio communications. Operation of this equipment in a residential area is likely to cause harmful interference in which case the user will be required to correct the interference at his own expense.

FCC Interference Statement for Class B EVM devices

NOTE: This equipment has been tested and found to comply with the limits for a Class B digital device, pursuant to part 15 of the FCC Rules. These limits are designed to provide reasonable protection against harmful interference in a residential installation. This equipment generates, uses and can radiate radio frequency energy and, if not installed and used in accordance with the instructions, may cause harmful interference to radio communications. However, there is no guarantee that interference will not occur in a particular installation. If this equipment does cause harmful interference to radio or television reception, which can be determined by turning the equipment off and on, the user is encouraged to try to correct the interference by one or more of the following measures:

- Reorient or relocate the receiving antenna.
- Increase the separation between the equipment and receiver.
- Connect the equipment into an outlet on a circuit different from that to which the receiver is connected.
- Consult the dealer or an experienced radio/TV technician for help.

3.2 Canada

3.2.1 For EVMs issued with an Industry Canada Certificate of Conformance to RSS-210 or RSS-247

Concerning EVMs Including Radio Transmitters:

This device complies with Industry Canada license-exempt RSSs. Operation is subject to the following two conditions:

(1) this device may not cause interference, and (2) this device must accept any interference, including interference that may cause undesired operation of the device.

Concernant les EVMs avec appareils radio:

Le présent appareil est conforme aux CNR d'Industrie Canada applicables aux appareils radio exempts de licence. L'exploitation est autorisée aux deux conditions suivantes: (1) l'appareil ne doit pas produire de brouillage, et (2) l'utilisateur de l'appareil doit accepter tout brouillage radioélectrique subi, même si le brouillage est susceptible d'en compromettre le fonctionnement.

Concerning EVMs Including Detachable Antennas:

Under Industry Canada regulations, this radio transmitter may only operate using an antenna of a type and maximum (or lesser) gain approved for the transmitter by Industry Canada. To reduce potential radio interference to other users, the antenna type and its gain should be so chosen that the equivalent isotropically radiated power (e.i.r.p.) is not more than that necessary for successful communication. This radio transmitter has been approved by Industry Canada to operate with the antenna types listed in the user guide with the maximum permissible gain and required antenna impedance for each antenna type indicated. Antenna types not included in this list, having a gain greater than the maximum gain indicated for that type, are strictly prohibited for use with this device.

Concernant les EVMs avec antennes détachables

Conformément à la réglementation d'Industrie Canada, le présent émetteur radio peut fonctionner avec une antenne d'un type et d'un gain maximal (ou inférieur) approuvé pour l'émetteur par Industrie Canada. Dans le but de réduire les risques de brouillage radioélectrique à l'intention des autres utilisateurs, il faut choisir le type d'antenne et son gain de sorte que la puissance isotrope rayonnée équivalente (p.i.r.e.) ne dépasse pas l'intensité nécessaire à l'établissement d'une communication satisfaisante. Le présent émetteur radio a été approuvé par Industrie Canada pour fonctionner avec les types d'antenne énumérés dans le manuel d'usage et ayant un gain admissible maximal et l'impédance requise pour chaque type d'antenne. Les types d'antenne non inclus dans cette liste, ou dont le gain est supérieur au gain maximal indiqué, sont strictement interdits pour l'exploitation de l'émetteur.

3.3 Japan

3.3.1 *Notice for EVMs delivered in Japan:* Please see http://www.tij.co.jp/lstds/ti_ja/general/eStore/notice_01.page 日本国内に輸入される評価用キット、ボードについては、次のところをご覧ください。
http://www.tij.co.jp/lstds/ti_ja/general/eStore/notice_01.page

3.3.2 *Notice for Users of EVMs Considered "Radio Frequency Products" in Japan:* EVMs entering Japan may not be certified by TI as conforming to Technical Regulations of Radio Law of Japan.

If User uses EVMs in Japan, not certified to Technical Regulations of Radio Law of Japan, User is required to follow the instructions set forth by Radio Law of Japan, which includes, but is not limited to, the instructions below with respect to EVMs (which for the avoidance of doubt are stated strictly for convenience and should be verified by User):

1. Use EVMs in a shielded room or any other test facility as defined in the notification #173 issued by Ministry of Internal Affairs and Communications on March 28, 2006, based on Sub-section 1.1 of Article 6 of the Ministry's Rule for Enforcement of Radio Law of Japan,
2. Use EVMs only after User obtains the license of Test Radio Station as provided in Radio Law of Japan with respect to EVMs, or
3. Use of EVMs only after User obtains the Technical Regulations Conformity Certification as provided in Radio Law of Japan with respect to EVMs. Also, do not transfer EVMs, unless User gives the same notice above to the transferee. Please note that if User does not follow the instructions above, User will be subject to penalties of Radio Law of Japan.

【無線電波を送信する製品の開発キットをお使いになる際の注意事項】 開発キットの中には技術基準適合証明を受けていないものがあります。技術適合証明を受けていないものご使用に際しては、電波法遵守のため、以下のいずれかの措置を取っていただく必要がありますのでご注意ください。

1. 電波法施行規則第6条第1項第1号に基づく平成18年3月28日総務省告示第173号で定められた電波暗室等の試験設備でご使用いただく。
2. 実験局の免許を取得後ご使用いただく。
3. 技術基準適合証明を取得後ご使用いただく。

なお、本製品は、上記の「ご使用にあたっての注意」を譲渡先、移転先に通知しない限り、譲渡、移転できないものとします。

上記を遵守頂けない場合は、電波法の罰則が適用される可能性があることをご留意ください。日本テキサス・インスツルメンツ株式会社
東京都新宿区西新宿 6 丁目 2 4 番 1 号
西新宿三井ビル

3.3.3 *Notice for EVMs for Power Line Communication:* Please see http://www.tij.co.jp/lstds/ti_ja/general/eStore/notice_02.page
電力線搬送波通信についての開発キットをお使いになる際の注意事項については、次のところをご覧ください。http://www.tij.co.jp/lstds/ti_ja/general/eStore/notice_02.page

3.4 European Union

3.4.1 *For EVMs subject to EU Directive 2014/30/EU (Electromagnetic Compatibility Directive):*

This is a class A product intended for use in environments other than domestic environments that are connected to a low-voltage power-supply network that supplies buildings used for domestic purposes. In a domestic environment this product may cause radio interference in which case the user may be required to take adequate measures.

-
4. *EVM Use Restrictions and Warnings:*
 - 4.1 EVMS ARE NOT FOR USE IN FUNCTIONAL SAFETY AND/OR SAFETY CRITICAL EVALUATIONS, INCLUDING BUT NOT LIMITED TO EVALUATIONS OF LIFE SUPPORT APPLICATIONS.
 - 4.2 User must read and apply the user guide and other available documentation provided by TI regarding the EVM prior to handling or using the EVM, including without limitation any warning or restriction notices. The notices contain important safety information related to, for example, temperatures and voltages.
 - 4.3 *Safety-Related Warnings and Restrictions:*
 - 4.3.1 User shall operate the EVM within TI's recommended specifications and environmental considerations stated in the user guide, other available documentation provided by TI, and any other applicable requirements and employ reasonable and customary safeguards. Exceeding the specified performance ratings and specifications (including but not limited to input and output voltage, current, power, and environmental ranges) for the EVM may cause personal injury or death, or property damage. If there are questions concerning performance ratings and specifications, User should contact a TI field representative prior to connecting interface electronics including input power and intended loads. Any loads applied outside of the specified output range may also result in unintended and/or inaccurate operation and/or possible permanent damage to the EVM and/or interface electronics. Please consult the EVM user guide prior to connecting any load to the EVM output. If there is uncertainty as to the load specification, please contact a TI field representative. During normal operation, even with the inputs and outputs kept within the specified allowable ranges, some circuit components may have elevated case temperatures. These components include but are not limited to linear regulators, switching transistors, pass transistors, current sense resistors, and heat sinks, which can be identified using the information in the associated documentation. When working with the EVM, please be aware that the EVM may become very warm.
 - 4.3.2 EVMs are intended solely for use by technically qualified, professional electronics experts who are familiar with the dangers and application risks associated with handling electrical mechanical components, systems, and subsystems. User assumes all responsibility and liability for proper and safe handling and use of the EVM by User or its employees, affiliates, contractors or designees. User assumes all responsibility and liability to ensure that any interfaces (electronic and/or mechanical) between the EVM and any human body are designed with suitable isolation and means to safely limit accessible leakage currents to minimize the risk of electrical shock hazard. User assumes all responsibility and liability for any improper or unsafe handling or use of the EVM by User or its employees, affiliates, contractors or designees.
 - 4.4 User assumes all responsibility and liability to determine whether the EVM is subject to any applicable international, federal, state, or local laws and regulations related to User's handling and use of the EVM and, if applicable, User assumes all responsibility and liability for compliance in all respects with such laws and regulations. User assumes all responsibility and liability for proper disposal and recycling of the EVM consistent with all applicable international, federal, state, and local requirements.
 5. *Accuracy of Information:* To the extent TI provides information on the availability and function of EVMs, TI attempts to be as accurate as possible. However, TI does not warrant the accuracy of EVM descriptions, EVM availability or other information on its websites as accurate, complete, reliable, current, or error-free.
 6. *Disclaimers:*
 - 6.1 EXCEPT AS SET FORTH ABOVE, EVMS AND ANY MATERIALS PROVIDED WITH THE EVM (INCLUDING, BUT NOT LIMITED TO, REFERENCE DESIGNS AND THE DESIGN OF THE EVM ITSELF) ARE PROVIDED "AS IS" AND "WITH ALL FAULTS." TI DISCLAIMS ALL OTHER WARRANTIES, EXPRESS OR IMPLIED, REGARDING SUCH ITEMS, INCLUDING BUT NOT LIMITED TO ANY EPIDEMIC FAILURE WARRANTY OR IMPLIED WARRANTIES OF MERCHANTABILITY OR FITNESS FOR A PARTICULAR PURPOSE OR NON-INFRINGEMENT OF ANY THIRD PARTY PATENTS, COPYRIGHTS, TRADE SECRETS OR OTHER INTELLECTUAL PROPERTY RIGHTS.
 - 6.2 EXCEPT FOR THE LIMITED RIGHT TO USE THE EVM SET FORTH HEREIN, NOTHING IN THESE TERMS SHALL BE CONSTRUED AS GRANTING OR CONFERRING ANY RIGHTS BY LICENSE, PATENT, OR ANY OTHER INDUSTRIAL OR INTELLECTUAL PROPERTY RIGHT OF TI, ITS SUPPLIERS/LICENSORS OR ANY OTHER THIRD PARTY, TO USE THE EVM IN ANY FINISHED END-USER OR READY-TO-USE FINAL PRODUCT, OR FOR ANY INVENTION, DISCOVERY OR IMPROVEMENT, REGARDLESS OF WHEN MADE, CONCEIVED OR ACQUIRED.
 7. *USER'S INDEMNITY OBLIGATIONS AND REPRESENTATIONS.* USER WILL DEFEND, INDEMNIFY AND HOLD TI, ITS LICENSORS AND THEIR REPRESENTATIVES HARMLESS FROM AND AGAINST ANY AND ALL CLAIMS, DAMAGES, LOSSES, EXPENSES, COSTS AND LIABILITIES (COLLECTIVELY, "CLAIMS") ARISING OUT OF OR IN CONNECTION WITH ANY HANDLING OR USE OF THE EVM THAT IS NOT IN ACCORDANCE WITH THESE TERMS. THIS OBLIGATION SHALL APPLY WHETHER CLAIMS ARISE UNDER STATUTE, REGULATION, OR THE LAW OF TORT, CONTRACT OR ANY OTHER LEGAL THEORY, AND EVEN IF THE EVM FAILS TO PERFORM AS DESCRIBED OR EXPECTED.
-

8. *Limitations on Damages and Liability:*

8.1 *General Limitations.* IN NO EVENT SHALL TI BE LIABLE FOR ANY SPECIAL, COLLATERAL, INDIRECT, PUNITIVE, INCIDENTAL, CONSEQUENTIAL, OR EXEMPLARY DAMAGES IN CONNECTION WITH OR ARISING OUT OF THESE TERMS OR THE USE OF THE EVMS , REGARDLESS OF WHETHER TI HAS BEEN ADVISED OF THE POSSIBILITY OF SUCH DAMAGES. EXCLUDED DAMAGES INCLUDE, BUT ARE NOT LIMITED TO, COST OF REMOVAL OR REINSTALLATION, ANCILLARY COSTS TO THE PROCUREMENT OF SUBSTITUTE GOODS OR SERVICES, RETESTING, OUTSIDE COMPUTER TIME, LABOR COSTS, LOSS OF GOODWILL, LOSS OF PROFITS, LOSS OF SAVINGS, LOSS OF USE, LOSS OF DATA, OR BUSINESS INTERRUPTION. NO CLAIM, SUIT OR ACTION SHALL BE BROUGHT AGAINST TI MORE THAN TWELVE (12) MONTHS AFTER THE EVENT THAT GAVE RISE TO THE CAUSE OF ACTION HAS OCCURRED.

8.2 *Specific Limitations.* IN NO EVENT SHALL TI'S AGGREGATE LIABILITY FROM ANY USE OF AN EVM PROVIDED HEREUNDER, INCLUDING FROM ANY WARRANTY, INDEMNITY OR OTHER OBLIGATION ARISING OUT OF OR IN CONNECTION WITH THESE TERMS, , EXCEED THE TOTAL AMOUNT PAID TO TI BY USER FOR THE PARTICULAR EVM(S) AT ISSUE DURING THE PRIOR TWELVE (12) MONTHS WITH RESPECT TO WHICH LOSSES OR DAMAGES ARE CLAIMED. THE EXISTENCE OF MORE THAN ONE CLAIM SHALL NOT ENLARGE OR EXTEND THIS LIMIT.

9. *Return Policy.* Except as otherwise provided, TI does not offer any refunds, returns, or exchanges. Furthermore, no return of EVM(s) will be accepted if the package has been opened and no return of the EVM(s) will be accepted if they are damaged or otherwise not in a resalable condition. If User feels it has been incorrectly charged for the EVM(s) it ordered or that delivery violates the applicable order, User should contact TI. All refunds will be made in full within thirty (30) working days from the return of the components(s), excluding any postage or packaging costs.

10. *Governing Law:* These terms and conditions shall be governed by and interpreted in accordance with the laws of the State of Texas, without reference to conflict-of-laws principles. User agrees that non-exclusive jurisdiction for any dispute arising out of or relating to these terms and conditions lies within courts located in the State of Texas and consents to venue in Dallas County, Texas. Notwithstanding the foregoing, any judgment may be enforced in any United States or foreign court, and TI may seek injunctive relief in any United States or foreign court.

Mailing Address: Texas Instruments, Post Office Box 655303, Dallas, Texas 75265
Copyright © 2019, Texas Instruments Incorporated

IMPORTANT NOTICE AND DISCLAIMER

TI PROVIDES TECHNICAL AND RELIABILITY DATA (INCLUDING DATASHEETS), DESIGN RESOURCES (INCLUDING REFERENCE DESIGNS), APPLICATION OR OTHER DESIGN ADVICE, WEB TOOLS, SAFETY INFORMATION, AND OTHER RESOURCES "AS IS" AND WITH ALL FAULTS, AND DISCLAIMS ALL WARRANTIES, EXPRESS AND IMPLIED, INCLUDING WITHOUT LIMITATION ANY IMPLIED WARRANTIES OF MERCHANTABILITY, FITNESS FOR A PARTICULAR PURPOSE OR NON-INFRINGEMENT OF THIRD PARTY INTELLECTUAL PROPERTY RIGHTS.

These resources are intended for skilled developers designing with TI products. You are solely responsible for (1) selecting the appropriate TI products for your application, (2) designing, validating and testing your application, and (3) ensuring your application meets applicable standards, and any other safety, security, or other requirements. These resources are subject to change without notice. TI grants you permission to use these resources only for development of an application that uses the TI products described in the resource. Other reproduction and display of these resources is prohibited. No license is granted to any other TI intellectual property right or to any third party intellectual property right. TI disclaims responsibility for, and you will fully indemnify TI and its representatives against, any claims, damages, costs, losses, and liabilities arising out of your use of these resources.

TI's products are provided subject to TI's Terms of Sale (www.ti.com/legal/termsofsale.html) or other applicable terms available either on ti.com or provided in conjunction with such TI products. TI's provision of these resources does not expand or otherwise alter TI's applicable warranties or warranty disclaimers for TI products.

Mailing Address: Texas Instruments, Post Office Box 655303, Dallas, Texas 75265
Copyright © 2019, Texas Instruments Incorporated