

**VOLTAGE CONTROLLED CRYSTAL OSCILLATORS** (SMD • Ceramic Package)

**RoHS compliant CSX-750V SERIES 2000pcs/reel**



**FEATURES**

- Available to supply voltage 5.0V or 3.3V.
- Most appropriate for communication devices and other equipment.
- Output enable function (OE) can be used for low power consumption.

**DIMENSION [mm]**

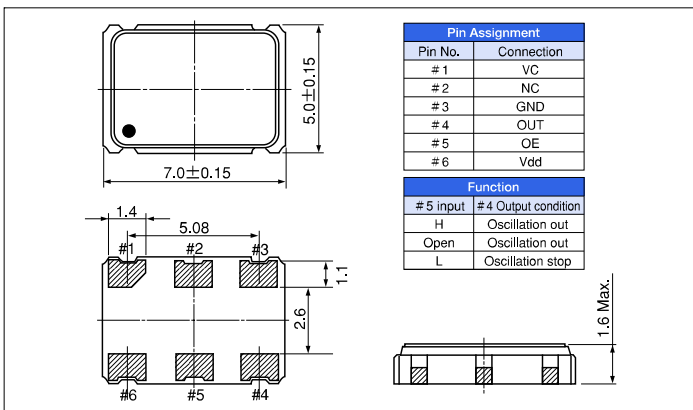

**SOLDER PAD LAYOUT [mm]**

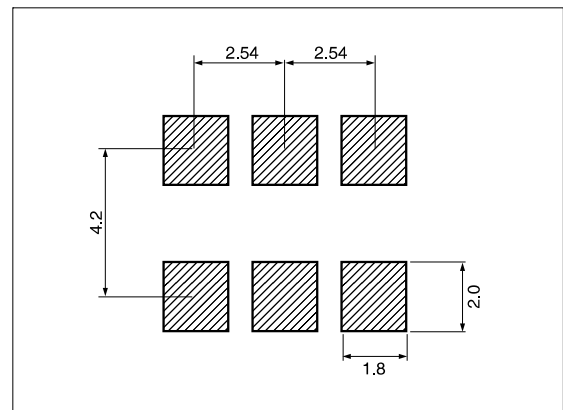

**STANDARD SPECIFICATIONS**

\* Model is determined by the supply voltage and the frequency stability.

Item	Model	CSX-750 VJ(*) M	CSX-750 VK(*) L
Frequency Range		2.000MHz ~ 40.000MHz	
Supply Voltage		Vdd : 5.0V±0.5V	Vdd : 3.3V±0.3V
Frequency Stability	(*)	B : ±50ppm (−20°C~+70°C), E : ±50ppm (−40°C~+85°C)	
Operating Temperature Range		−20°C~+70°C (−40°C~+85°C)	
Storage Temperature Range		−55°C~+125°C	
Pulling range		M : ±100ppm Min. / Vc=2.5±2.0V	L : ±90ppm Min. / Vc=1.65±1.65V
Frequency control voltage		2.5±2.0V (at 25°C)	1.65±1.65V (at 25°C)
Current consumption		15mA Max.	10mA Max.
Disable current		10mA Max.	6mA Max.
Linearity		10% Max.	
Duty	CMOS level (1/2 Vdd)	45~55%	
Output Voltage	V <sub>OH</sub>	Vdd−0.4V Min.	0.9Vdd Min.
	V <sub>OL</sub>	0.4V Max.	0.1Vdd Max.
Output Load		CMOS 30pF Max.	
Rise and Fall Time		6 nsec Max.	
Start-up time	(tr,tf)	4 msec Max.	
Modulation band width		15kHz Min. (Gain−3dB)	
Phase Noise		−120dBc/Hz Max. (Offset 1kHz)	