

Items	Specification	Unit
Center frequency(Fo)	915.000	MHz
Bandwidth (902~928MHz)	26000	kHz
Insertion Loss (902~928MHz),typ/max	2.3 / 3.0	dB
Amplitude Ripple (902~928MHz), typ/max	0.6 / 1.0	dB
In/Out Return Loss (902~928MHz), min/typ	10 / 13	dB
Group Delay (902~928MHz), typ/max	20/50	ns
Attenuation min/typ	10.0 MHz ~ 857.5 MHz	-40 / -45
	857.5 MHz ~ 882.5 MHz	-35 / -40
	970.0 MHz ~ 1005.0 MHz	-35 / -43
	1005.0 MHz ~ 1110.0 MHz	-40 / -45
	1110.0 MHz ~ 3000.0 MHz	-30 / -37
In/Out Impedance	50	Ω
DC Voltage, max	5	V
Input power, Maximum	10	dBm
Operating Temperature Range	-40 to +85	$^{\circ}\text{C}$
Storage Temperature Range	-40 to +85	$^{\circ}\text{C}$

Dimension

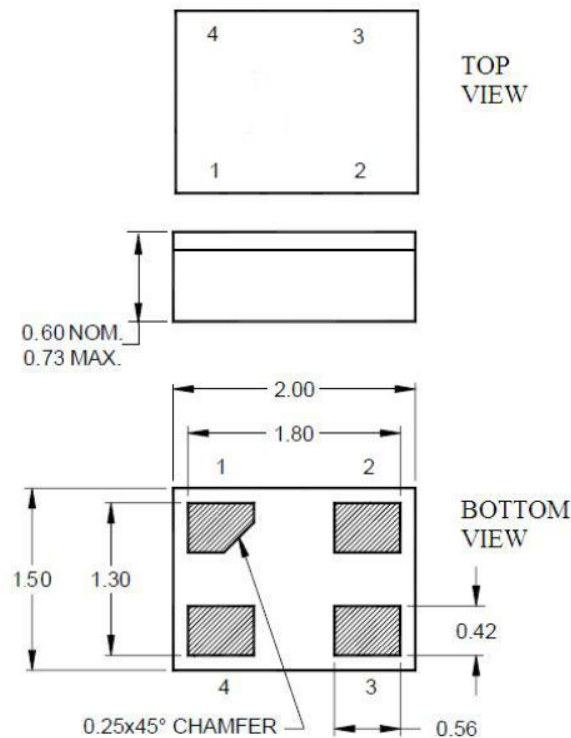

Pin Description	
2,4	Ground
1	In
3	Out

Frequency Characteristics

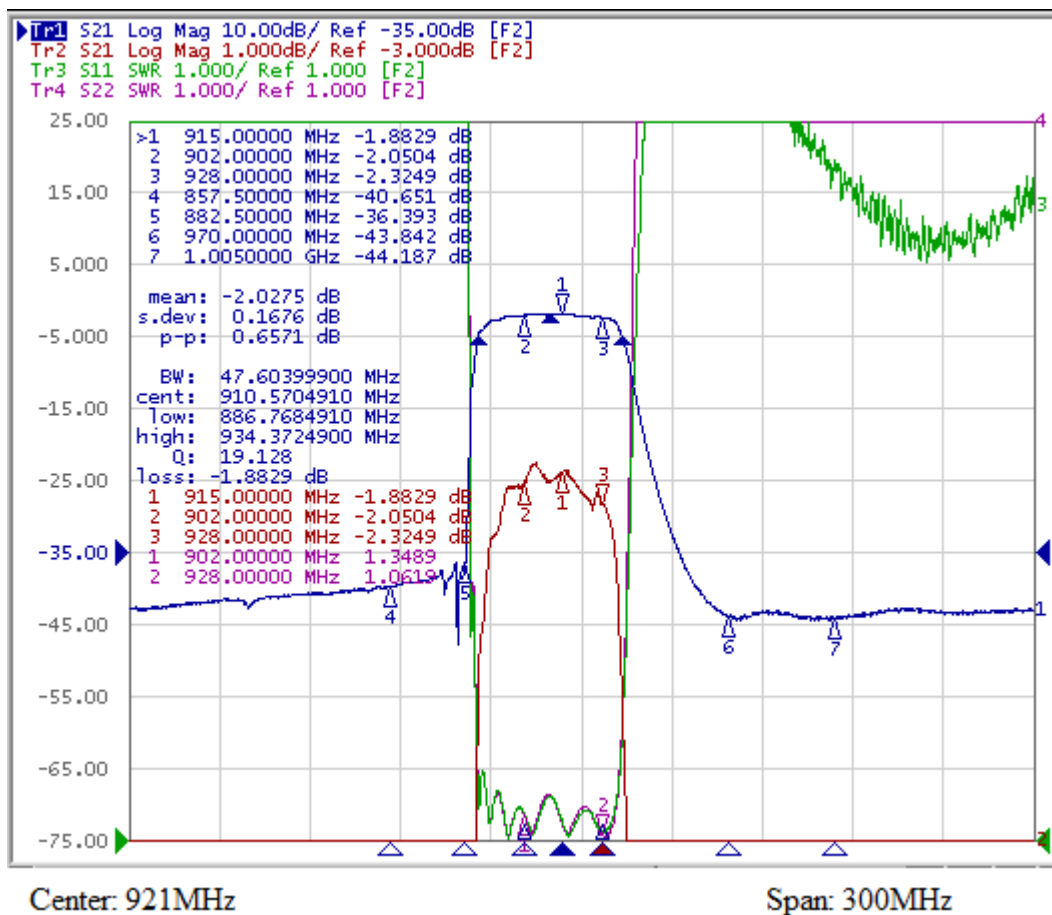

Test Circuit

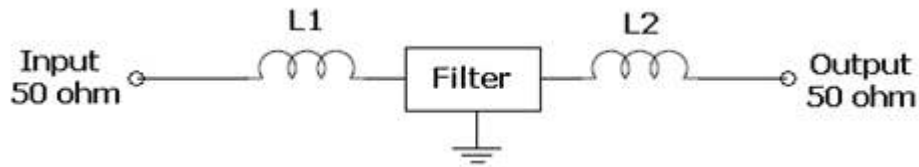

L1=L2=2nH

Note: Test circuit for reference only. Please adjust matching circuit, according to actual usage.

Environmental

PARAMETER	VALUE
MOISTURE SENSITIVITY LEVEL	1
REACH – SVHC	Compliant
RoHS 2	6/6

● **APPROVAL**

DRAWN BY	CP, February 24, 2016
APPROVED BY	CP, February 24, 2016
REVISION	A, Initial Release