

Heating Controller

Features

- Dual Voltage (120V/240V) operations
- Auto temperature control with NTC
- NTC open protection
- Multi mode LED indicator
- Proportional control
- Pulse trigger for high current SCR
- Internal Zener
- Auto Heating off after heating timer timeout
- Low cost 8-Pin DIP and SOIC package

Applications

- Curler
- Straightener

Description

The PT8A3270/1/2/3/4/5/6/7 is a mixed signal CMOS LSI chip designed as heating controller with help of external NTC (Negative Temperature Component). NTC open protection is implemented for device safety. This device can be used in both 120V and 240V power line supplier, as it will automatically adjust the heating power according to the power line voltage to avoid heating appliance damage or long heating time. The proportional control algorithm is designed in this product.

Pin Configuration

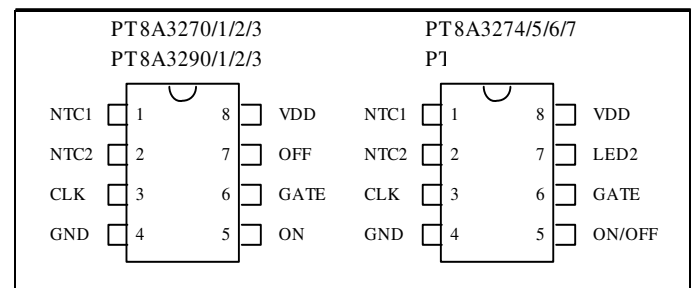

Pin Description

| Pin No. | Pin Name | | I/O | Description |
|---------|------------|------------|-------|---|
| | 3270/1/2/3 | 3274/5/6/7 | | |
| 1 | NTC1 | NTC1 | I | NTC voltage input, NTC open detection input |
| 2 | NTC2 | NTC2 | O | Output signal for NTC open detection |
| 3 | CLK | CLK | I | Clock input from power line |
| 4 | GND | GND | Power | Ground and Power |
| 5 | ON | ON_OFF | I/O | 3270/1/2/3: Heating-on button input. and LED1 driving output 3274/5/6/7: Heating-on/off button input and LED1 driving output |
| 6 | GATE | GATE | O | 3270/1/2/3/4/5/6/7: SCR trigger output |
| 7 | OFF | LED2 | I/O | 3270/1/2/3: Heating-off button input and LED2 driving output 3274/5/6/7: LED2 driving output |
| 8 | VDD | VDD | Power | Ground and Power |

Block Diagram

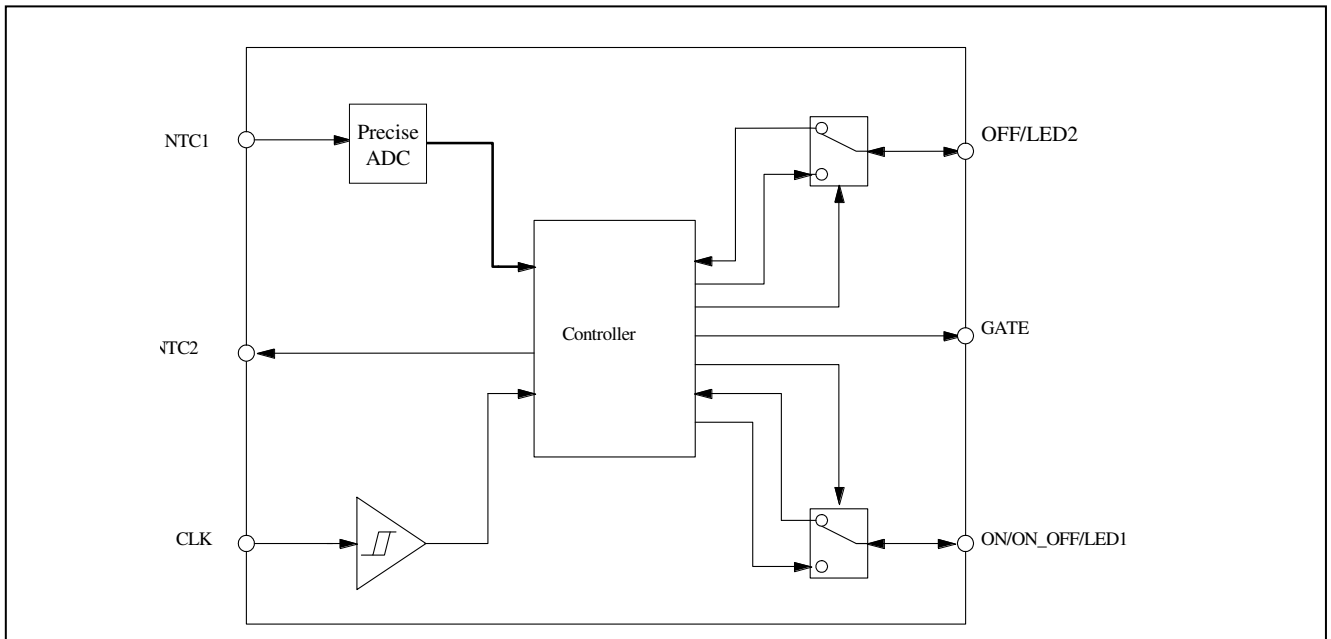

Maximum Ratings

| | |
|--|-----------------|
| Storage Temperature..... | -65°C to +150°C |
| Supply Voltage to Ground Potential (Input & V _{CC} Only)..... | -0.5V to +5.5V |
| Supply Voltage to Ground Potential (Outputs)..... | -0.5V to +5.5V |
| DC Input Voltage | -0.5V to +5.5V |
| DC Output Current..... | 20mA |
| Power Dissipation..... | 500mW |

Note:

Stresses greater than those listed under MAXIMUM RATINGS may cause permanent damage to the device. This is a stress rating only and functional operation of the device at these or any other conditions above those indicated in the operational sections of this specification is not implied. Exposure to absolute maximum rating conditions for extended periods may affect reliability.

Recommended operation conditions

| Symbol | Pin | Parameter | Min | Typ | Max | Unit |
|----------------|-----|-----------------------|-----|-------|-----|------|
| Frequency | CLK | Input CLK Frequency | - | 50/60 | - | Hz |
| T _A | - | Operating temperature | -20 | - | 85 | °C |

AC Electrical Characteristics

(V_{DD} = 3.5 ~ 5.5V, T_A = -20 ~ 85°C, unless otherwise noted)

| Symbol | Description | Test Conditions | Min | Type | Max | Unit |
|-------------------|------------------------|-------------------------|------|-------|------|------|
| F _{CLK} | Frequency of CLK | - | - | 50/60 | - | Hz |
| T _{GATE} | Width of trigger pulse | - | 160 | 200 | 240 | μS |
| Timer | Power off timer | F _{CLK} = 50Hz | 1.15 | 1.2 | 1.25 | Hour |

DC Electrical Characteristics

($V_{DD} = 3.5 \sim 5.5V$, $T_A = -20 \sim 85^\circ C$, unless otherwise noted)

| Symbol | Description | Test Conditions | | Min | Type | Max | Unit |
|-----------|---------------------|--|---|-----|------|------|---------|
| I_{IH} | Input high current | PIN: CLK | $V_{IN} = V_{DD}$ | - | - | 1 | μA |
| | | PIN: NTC1 | $V_{IN} = V_{DD}$ | - | - | 100 | nA |
| | | PIN: NTC2 | $V_{IN} = V_{DD}$, Output High impedance | - | - | 100 | nA |
| I_{IL} | Input low current | PIN: CLK | $V_{IN} = GND$ | - | - | -1 | μA |
| | | | $V_{IN} = 0.35V$ | - | - | -10 | μA |
| | | PIN: NTC1 | $V_{IN} = GND$ | - | - | -100 | nA |
| | | PIN: NTC2 | $V_{IN} = GND$, Output High impedance | - | - | -100 | nA |
| I_{OH} | Output High current | PIN: GATE | $V_{DD} = 4.5V$ $V_{out} = 2.5V$ | -15 | - | - | mA |
| I_{OL} | Output Low current | PIN: NTC2 | $V_{DD} = 4.5V$ $V_{out} = 0.5V$ | 2.0 | - | - | mA |
| | | PIN: GATE | $V_{DD} = 4.5V$ $V_{out} = 0.5V$ | 5.0 | - | - | mA |
| V_{POR} | Voltage of POR | - | | 1.5 | - | 2.5 | V |
| V_Z | Voltage of Zener | $I_{DD} = 500\mu A \sim 10mA$ | | 4.5 | 5.0 | 5.5 | V |
| I_{DD} | Current consumption | NTC1,CLK pin tied to ground $V_{DD} = 4.5V$ | | - | - | 500 | μA |

Application Circuit

PT8A3270/1/2/3 Application Circuit

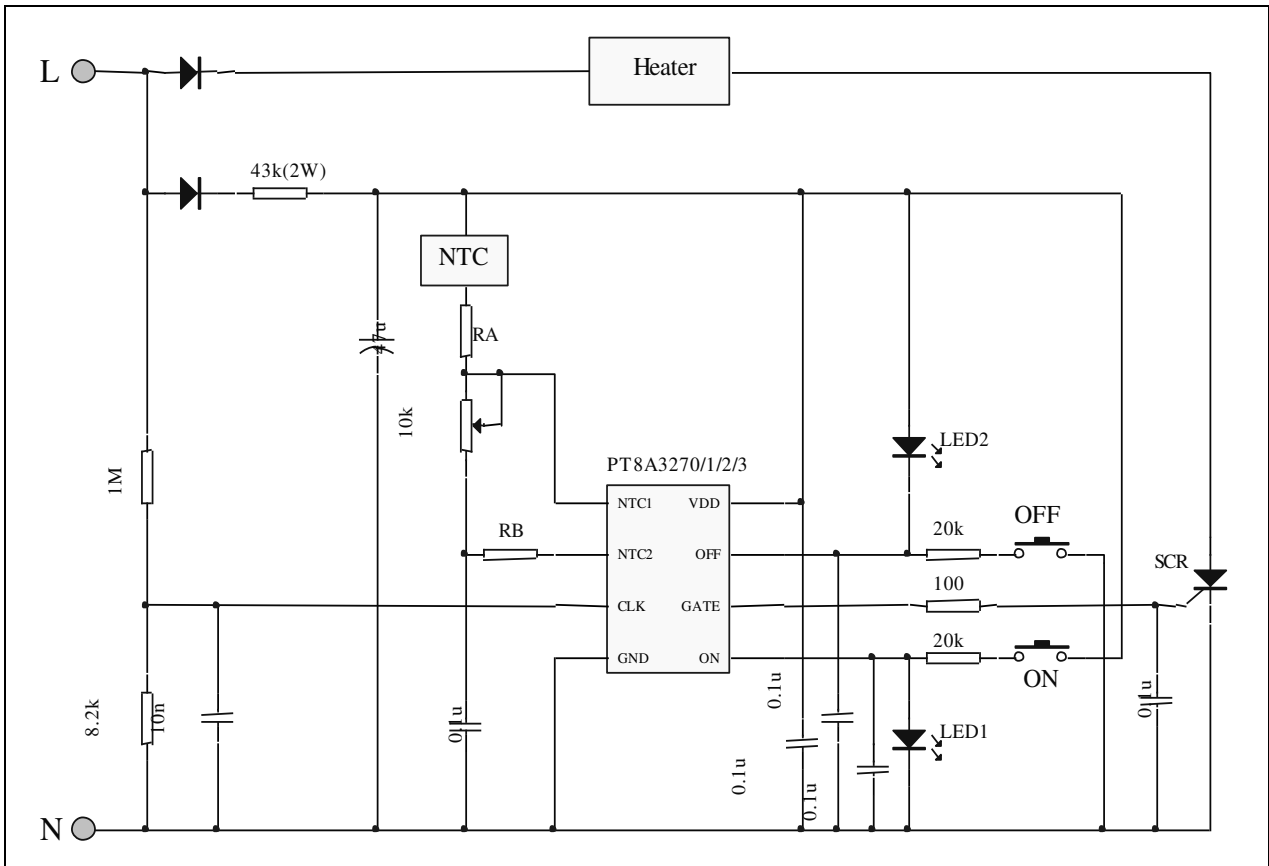

PT8A3274/5/6/7 Application circuit

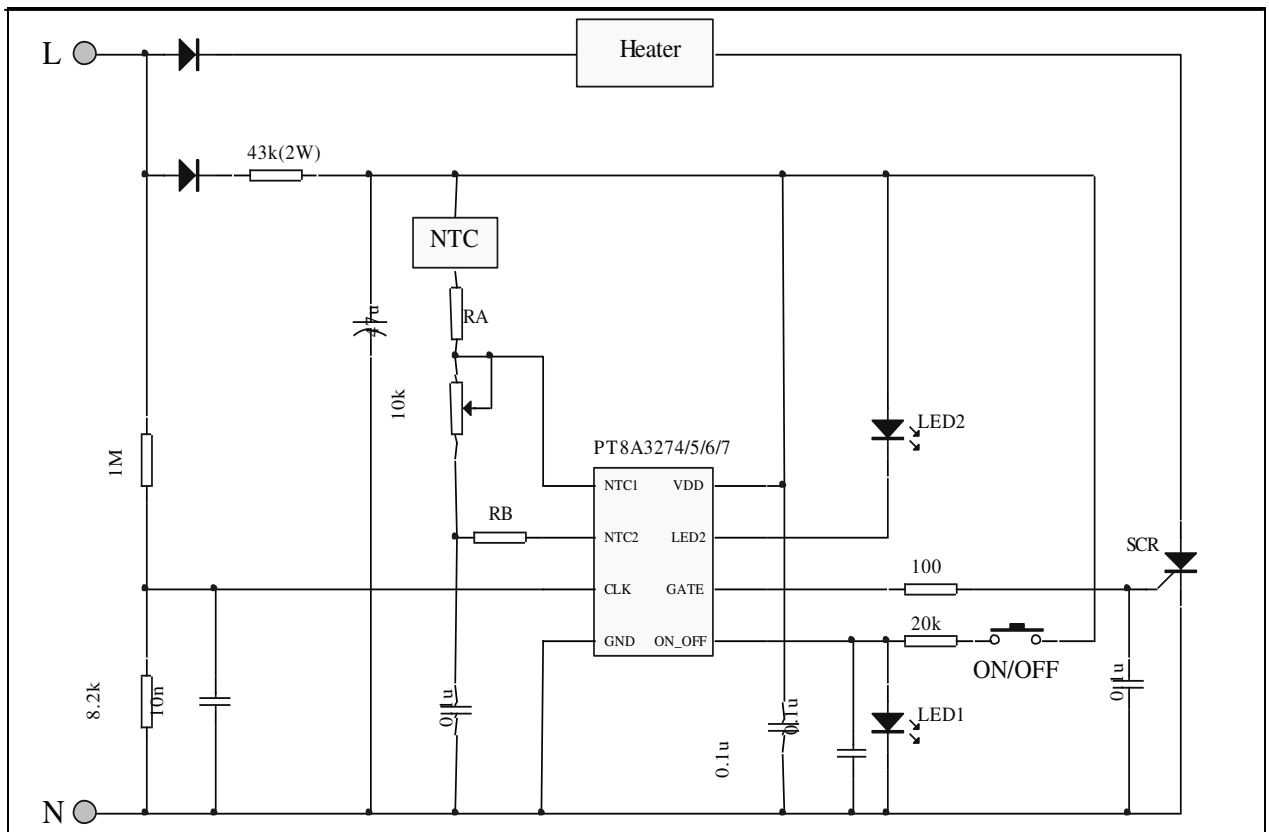

Functional Description

- **State description**

- **Reset**

The device will be of reset state after power-on.

- **Heating on**

The device will be of heating on state after heating-on button is on

- **Heating off**

This device enter heating-off state after its power-on reset or heating timer timeout, and all pins will be the same status as after power-on reset.

- **NTC open protection**

When NTC is open, NTC1 pin will be pulled low in the period of NTC open detected.

- **Timer**

Once IC enters Heating-on State, internal timer starts to count. When time is out after 216000 clock period, it will exit heating-on state. That is, in case of 60Hz CLK signal, the heating time is about 1 hour; and 1.2 hour for 50Hz.

In heating-on state, temperature is regulated to the selected temperature by the IC through NTC close control loop.

- **Control signal output**

When working in Heating-on state, Gate/LED output will be related to NTC1 input and CLK input amplitude.

Effect of NTC and $V_{T_{CLK}}$ (Level 2) on GATE and LED indication

| Working State | CLK input voltage | NTC (NTC open detection) | NTC (Normal temp detection) | GATE (trigger to SCR/TRIAC) | LED | | | |
|---------------|-------------------------|--------------------------|-------------------------------------|-----------------------------|------------|----------------|------------|------------|
| | | | | | LED1 | LED2 | LED1 | LED2 |
| | | | | | 3270/2/4/6 | 3270/2/4/6 | 3271/3/5/7 | 3271/3/5/7 |
| ON | High for level 2 (240V) | $V_{NTCO} \sim V_{DD}$ | $0 \sim V_{ADC_BIT15}$ | Proportional output | Flash1* | Invert of LED1 | On | Off |
| | | | $V_{ADC_BIT14} \sim V_{ADC_BIT1}$ | | On | | On | |
| | | | $V_{ADC_BIT1} \sim V_{DD}$ | | 0 | | On | On |
| | Low for level 2 (120V) | | $0 \sim V_{ADC_BIT15}$ | Proportional output | Flash1 | | On | Off |
| | | | $V_{ADC_BIT14} \sim V_{ADC_BIT1}$ | | On | | On | |
| | | | $V_{ADC_BIT1} \sim V_{DD}$ | | 0 | | On | On |
| Off | X* | | X | 0 | Off | Off | Off | |
| X | X | $0 \sim V_{NTCO}$ | X | 0 | Flash2* | Flash2* | Off | |

*Note: 1) X means any input. 2) Flash1 frequency is 1/32 clock. 3) Flash2 frequency is 1/8 clock

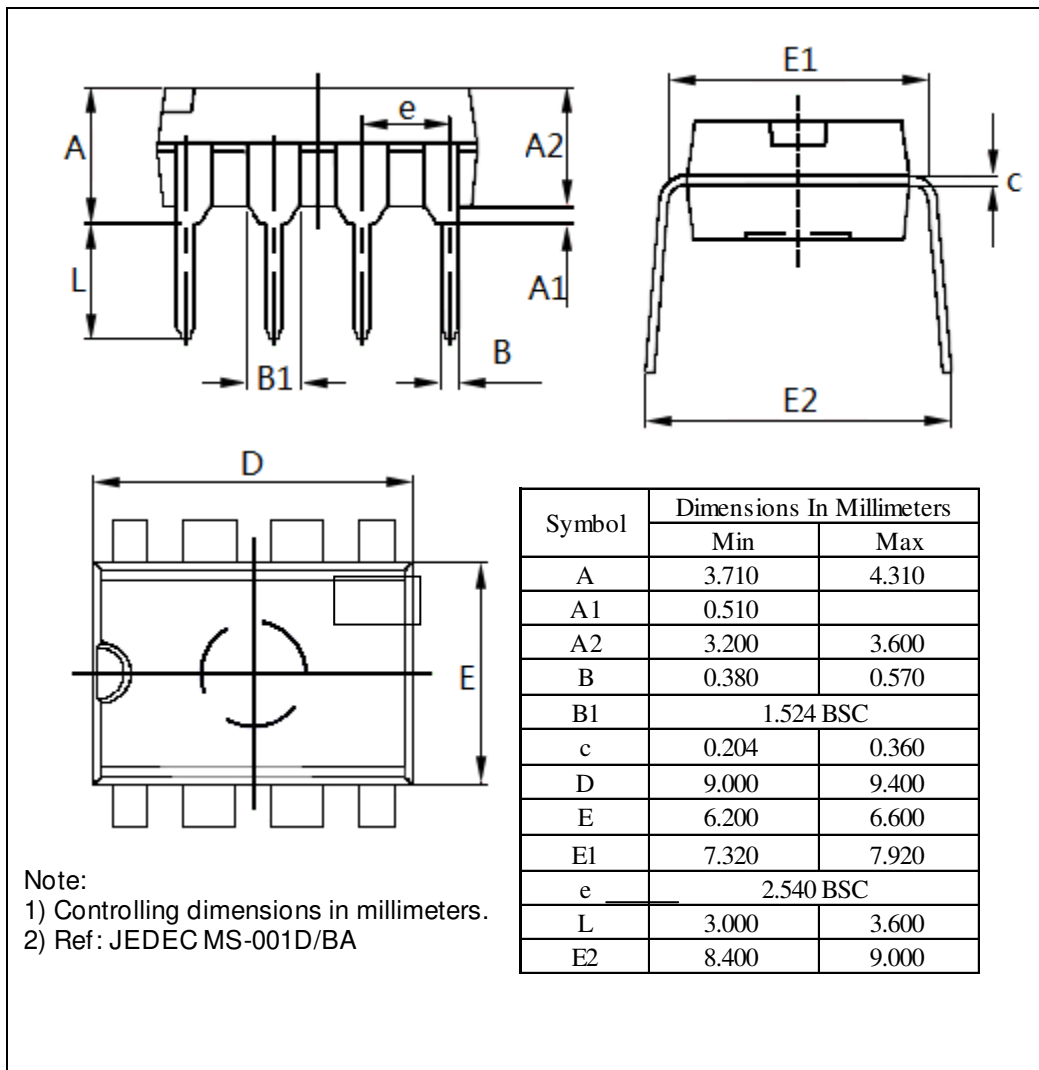
Mechanical Information
PE (DIP-8)

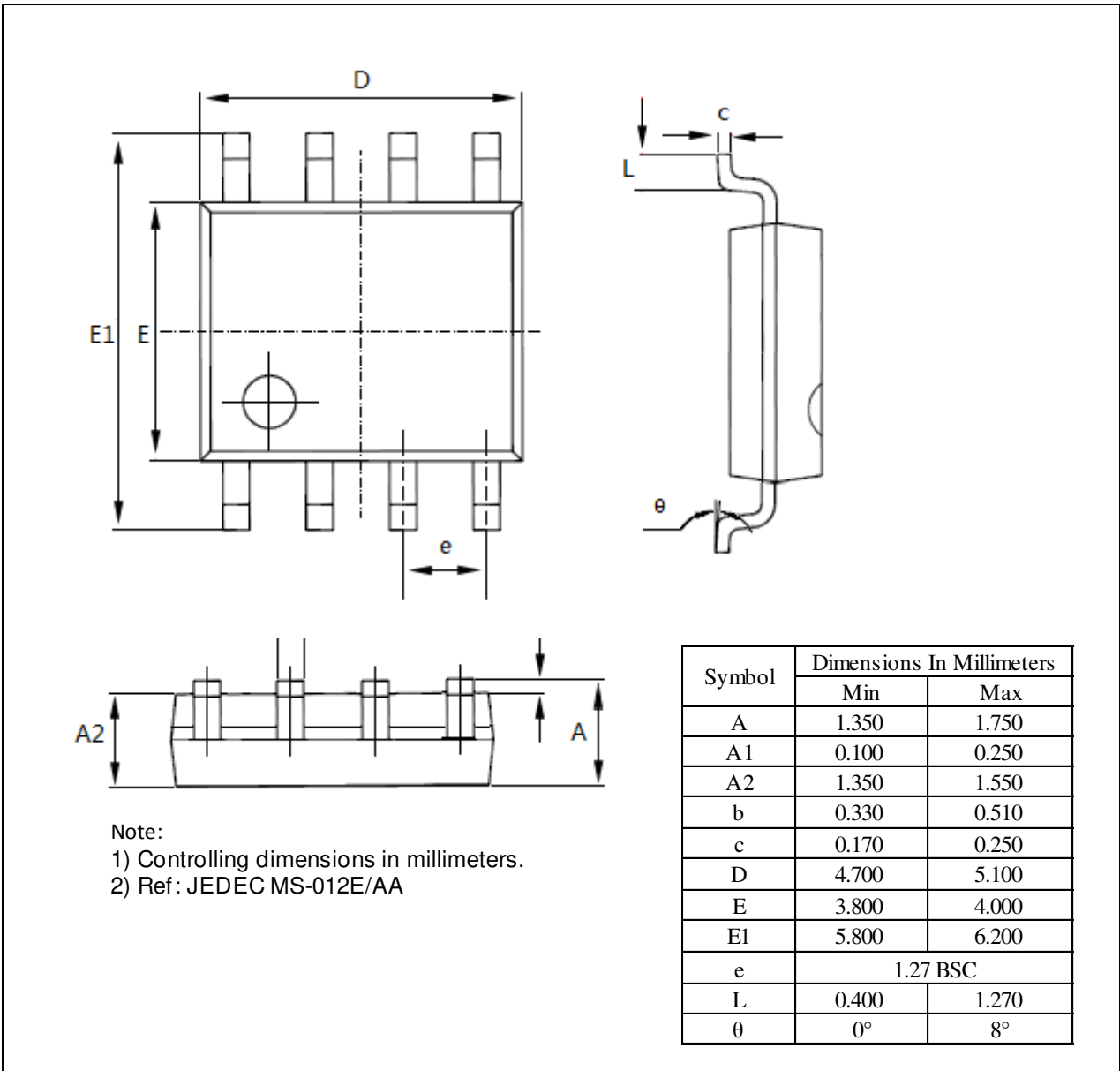
WE (SOIC-8)

Ordering Information

| Part No. | Package Code | Package |
|------------|--------------|--------------------------------|
| PT8A327xPE | P | Lead free 8-Pin DIP |
| PT8A327xWE | W | Lead free and Green 8-Pin SOIC |

Note:

- “x” shows 0~7 with different function see *Function Comparison Table*.
- E = Pb-free or Pb-free & Green
- Adding X Suffix= Tape/Reel

Function Comparison Table

| Part number | LED | Timer | Switch | Driver |
|-------------|----------|-------|--------------------|--------|
| PT8A3270 | Flash | Y | Two Key (ON + OFF) | SCR |
| PT8A3271* | Constant | Y | Two Key (ON + OFF) | SCR |
| PT8A3272* | Flash | N | Two Key (ON + OFF) | SCR |
| PT8A3273* | Constant | N | Two Key (ON + OFF) | SCR |
| PT8A3274 | Flash | Y | One key (ON_OFF) | SCR |
| PT8A3275 | Constant | Y | One key (ON_OFF) | SCR |
| PT8A3276* | Flash | N | One key (ON_OFF) | SCR |
| PT8A3277* | Constant | N | One key (ON_OFF) | SCR |

Note:

- *Contact Pericom for availability.