

HDSP-A2xC Series

Alphanumeric Display, 0.54" (13.7 mm)

2 Character As AlInGaP Red



Data Sheet

Description

These 0.54" (13.7 mm) AS AlInGaP displays are available in either common anode or common cathode.

Features

- As AlInGaP red color
- Gray face paint
Gray package gives optimum contrast
- Design flexibility
Common anode or common cathode

Devices

As AlInGaP Red	Description
HDSP-A22C	Common Anode
HDSP-A27C	Common Cathode

Applications

- Suitable for alphanumeric
- Operating temperature range -40°C to 105°C

Package Dimensions

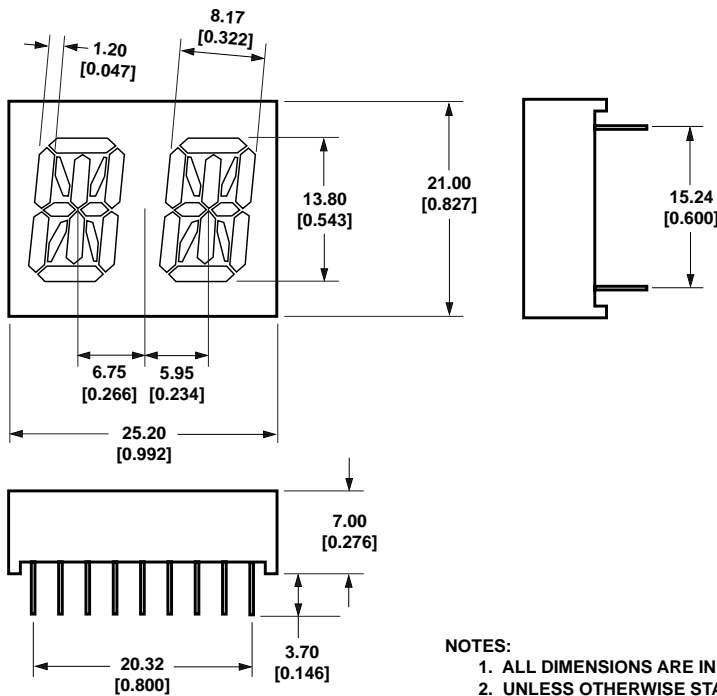

NOTES:

1. ALL DIMENSIONS ARE IN MILLIMETERS [INCHES]
2. UNLESS OTHERWISE STATED, TOLERANCES ARE ± 0.25 mm

Internal Circuit

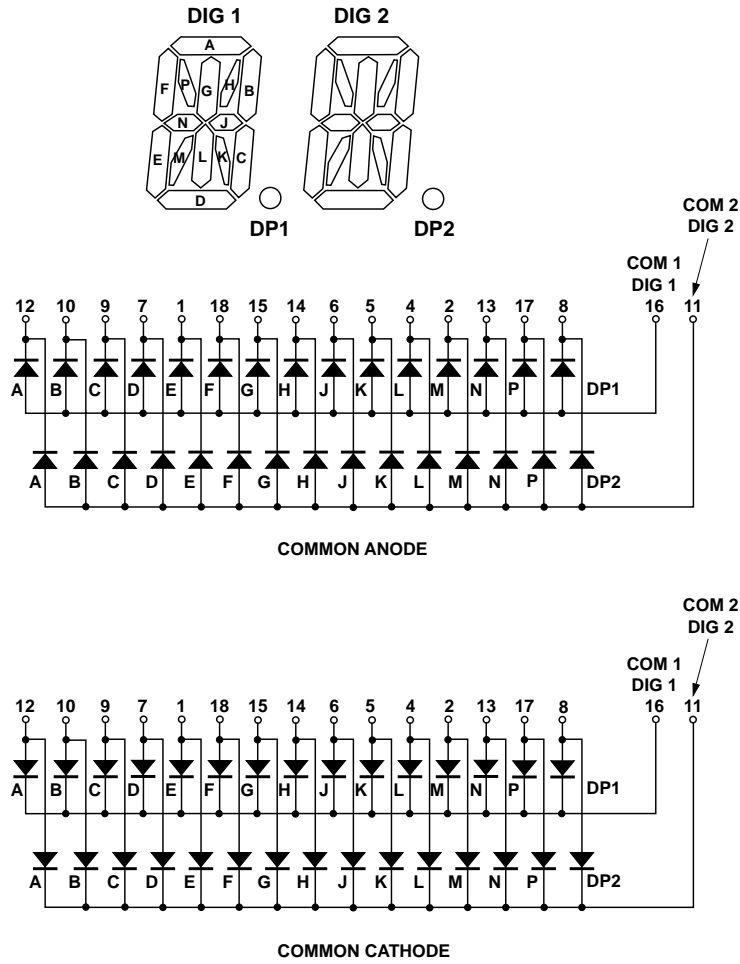

Pin	Pin Configuration A Common Anode	Pin Configuration B Common Cathode
1	1E/2E Cathode	1E/2E Anode
2	1M/2M Cathode	1M/2M Anode
3	No Connection	No Connection
4	1L/2L Cathode	1L/2L Anode
5	1K/2K Cathode	1K/2K Anode
6	1J/2J Cathode	1J/2J Anode
7	1D/2D Cathode	1D/2D Anode
8	DP1 Cathode	DP1 Anode
9	1C/2C Cathode	1C/2C Anode
10	1B/2B Cathode	1B/2B Anode
11	DIGIT No. 2 Common Anode	DIGIT No. 2 Common Cathode
12	1A/2A Cathode	1A/2A Anode
13	1N/2N Cathode	1N/2N Anode
14	1H/2H Cathode	1H/2H Anode
15	1G/2G Cathode	1G/2G Anode
16	DIGIT No. 1 Common Anode	DIGIT No. 1 Common Cathode
17	1P/2P Cathode	1P/2P Anode
18	1F/2F Cathode	1F/2F Anode

Absolute Maximum Ratings at T_A = 25 °C

Parameter	Symbol	HDSP-A22C/ HDSP-A27C	Units
DC Forward Current per Segment or DP ^[1,2,3]	I _F	50	mA
Peak Forward Current per Segment or DP ^[2,3]	I _{PEAK}	100	mA
Average Forward Current ^[3]	I _{AVE}	30	mA
Reverse Voltage per Segment or DP (I _R = 100 ∞A)	V _R	5	V
Operating Temperature	T _O	-40 to +105	°C
Storage Temperature	T _S	-40 to +120	°C
Wavesoldering Conditions	Temperature	250	°C
	Time	3	s

Notes:

1. Derate linearly as shown in Figure 1.
2. For long term performance with minimal light output degradation, drive currents between 10 mA and 30 mA are recommended. For more information on recommended drive conditions, please refer to Application Brief I-024 (5966-3087E).
3. Operating at currents below 1 mA is not recommended. Please contact your local representative for further information.

Optical/ Electrical Characteristics at T_A = 25 °C

Device Series		Symbol	Min.	Typ.	Max.	Units	Test Conditions
HDSP-A22C	Forward Voltage	V _F	1.70	1.90	2.20	V	I _F = 20 mA
HDSP-A27C	Reverse Voltage	V _R	5	20		V	I _F = 100 ∞A
	Peak Wavelength	λ _{PEAK}		635		nm	Peak Wavelength of Spectral Distribution at I _F = 20 mA
	Dominant Wavelength ^[3]	λ _d	622.5	626	630	nm	
	Spectral Halfwidth	Δλ _{1/2}		17		nm	Wavelength Width at Spectral Distribution 1/ 2 Power Point at I _F = 20 mA
	Speed of Response	τ _s		20		ns	Exponential Time Constant, e ^{-tτ_s}
	Capacitance	C		40		pF	V _F = 0, f = 1 MHz

Intensity Bin Limits^[1] (mcd at 10 mA)

Bin Name	Min. ^[2]	Max. ^[2]
T	18.0	25.0
U	25.0	36.0

Notes:

1. Bin categories are established for classification of products. Products may not be available in all bin categories.
2. Tolerance for each bin limit is ± 10%.

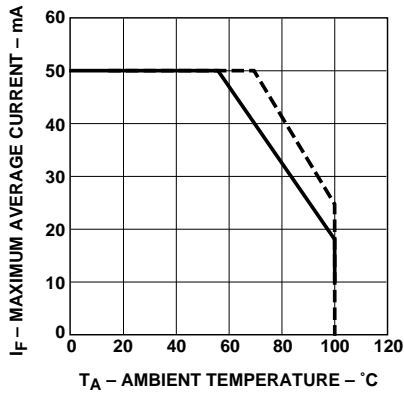

Figure 1. Maximum forward current vs. ambient temperature. Derating based on $T_{JM\text{MAX}} = 130^{\circ}\text{C}$.

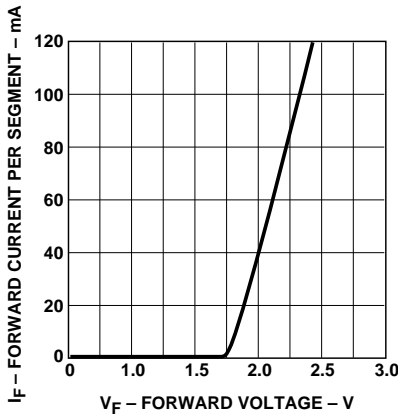

Figure 2. Forward current vs. forward voltage.

Contrast Enhancement

For information on contrast enhancement, please see Application Note 1015.

Soldering/ Cleaning

Cleaning agents from ketone family (acetone, methyl ethyl ketone, etc.) and from the chlorinated hydrocarbon family (methylene chloride, trichloroethylene, carbon tetrachloride, etc.) are not recommended for cleaning LED parts. All of these various solvents attack or dissolve the encapsulating epoxies used to form the package of plastic LED parts.

For information on soldering LEDs, please refer to Application Note 1027.

For product information and a complete list of distributors, please go to our website: www.avagotech.com

Avago, Avago Technologies, and the A logo are trademarks of Avago Technologies Limited in the United States and other countries. Data subject to change. Copyright © 2006 Avago Technologies Limited. All rights reserved. Obsoletes 5980-2919EN 5988-4821EN June 23, 2006

AVAGO
TECHNOLOGIES