

ENVELOPE / ASSEMBLY DRAWING

000182

SPECIFICATION CONTROL DRAWING	REV	DESCRIPTION	DWN	DATE	APPROVED
	A	ENGINEERING RELEASE	CZS	4/13/98	R. RICE

THIS DRAWING CONTAINS INFORMATION PROPRIETARY TO RF INDUSTRIES, LTD. ANY UNAUTHORIZED USE OF THIS DRAWING IS EXPRESSLY PROHIBITED. ANY VIOLATION IS PUNISHABLE UNDER U.S. COPYRIGHT LAWS.

ALL DIMENSIONS ARE REFERENCE ONLY

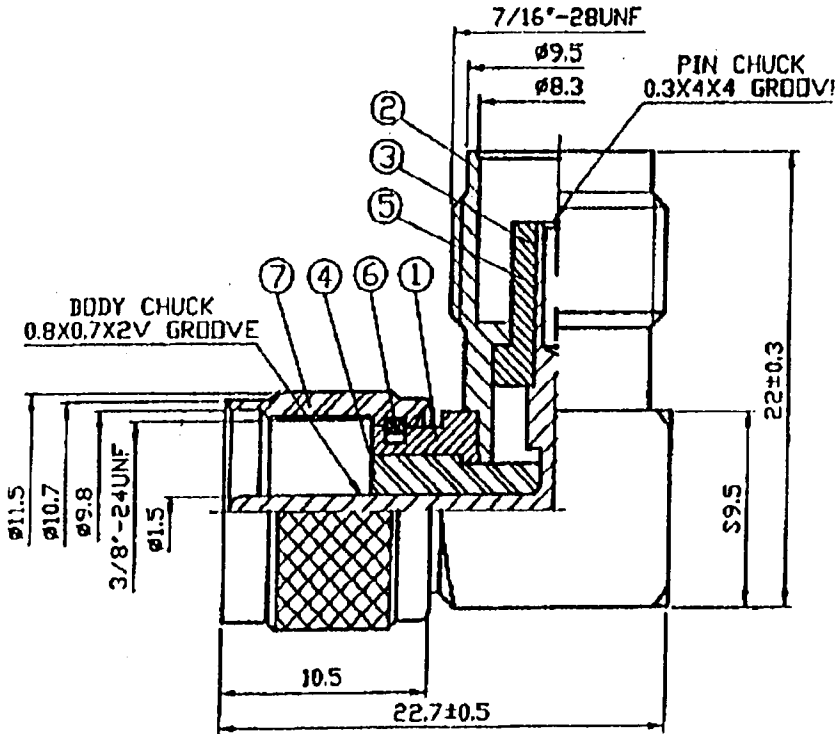

SPECIFICATIONS:

IMPEDANCE: 50 OHMS
 WORKING VOLTAGE: 335 VRMS @ SEA LEVEL
 FREQUENCY RANGE: 0-2.5 GHz
 INTERFACE PER MIL-STD-348A, SECTION 313.2

DIMENSIONS ARE IN INCHES AND [MILLIMETERS]

UNLESS OTHERWISE NOTED TOLERANCES ARE:

DECIMALS DIAMETER



7610 MIRAMAR RD
 SAN DIEGO, CA 92126
 (619)549-6340
 (619)549-6345 FAX

RFU-633

MINI UHF MALE TO TNC FEMALE ADAPTER

DRAWN
 C. ZUNIGA 4/13/98
 CHECKED
C. Zuniga 4/14/98
 ORJ DRAWN
 C. ZUNIGA 4/13/98

SIZE A	CABLE GROUP N/A	DWG NO. 8905	REV A
-----------	--------------------	-----------------	----------

ITEM	DESCRIPTION	QTY	MATERIAL	FINISH
7	SHELL	1	BRASS	NICKEL
6	RETAINING RING	1	BRASS	NICKEL
5	DIELECTRIC	1	TEFLON	NONE
4	DIELECTRIC	1	TEFLON	NONE
3	PIN	1	BRASS	GOLD
2	PRESS FIT BODY	1	BRASS	NICKEL
1	BODY	1	BRASS	NICKEL

APPROVALS	DATE	SCALE: 2:1	CAD FILE 13ARC B	SHEET 1 OF 1
-----------	------	------------	------------------	--------------