

8

7

6

5

4

3

DRW NO. C-926-401C-500 SH 1 REV D

ZONE	REV	ECN	DESCRIPTION	BY	DATE	APPROVED
SHT3, D3 SHT4, B2 SHT9, C5, C2	B	BWAG-A2FATP.VER01	DIM (4.40) WAS (4.50) DIM (4.60) WAS (4.50) DIM (13.60) WAS (13.50) REMOVED 85 OHM ON TITLE BLOCK REMOVED N & Z FROM 5TH DIGIT IN P/N TREE UPDATE NOTES 1 AND 10	HCL-PS	09/23/2015	B.W ANG
	C	DCOY-A8QN9P.VER01	UPDATED PART MARKING REQUIREMENTS	HCL-SD	05/10/2016	D.COVEY
SHT1 A8	D	JXUU-18013101	NOTE 7 UPDATED BY ADDING C-190-0009-000. UPDATED CONNECTOR MAXIMUM OVERALL DIMENSION.	HCL-SH	02/19/2018	J.XU

XCede HD PLUS BACKPLANE MODULE MALE STANDARD LOAD

9 2 6 - 4 X 1 C - X X X

4 PAIR

6-POSITION

LETTER	PLATING
D	NI SULFAMATE, STANDARD GOLD, LEADFREE
E	NI SULFAMATE, HIGH GOLD, LEADFREE
H	NANO NI, STANDARD GOLD, LEADFREE
J	NANO NI, HIGH GOLD, LEADFREE

NUMBER	PIN STYLE, HEIGHT
0	GUIDE PIN MACHINED, 28.5mm / OPEN MODULE

NUMBER	SIGNAL & LG. GROUND WIPE LENGTH, COMPLIANT PIN SIZE
1	2 mm WIPE SIGNAL, 4 mm WIPE LG GND, Ø.0217" DRILL
2	3 mm WIPE SIGNAL, 4 mm WIPE LG GND, Ø.0217" DRILL
3	2 mm WIPE SIGNAL, 4 mm WIPE LG GND, Ø.0177" DRILL
4	3 mm WIPE SIGNAL, 4 mm WIPE LG GND, Ø.0177" DRILL
5	2 mm WIPE SIGNAL, 3 mm WIPE LG GND, Ø.0217" DRILL
6	3 mm WIPE SIGNAL, 3 mm WIPE LG GND, Ø.0217" DRILL
7	2 mm WIPE SIGNAL, 3 mm WIPE LG GND, Ø.0177" DRILL
8	3 mm WIPE SIGNAL, 3 mm WIPE LG GND, Ø.0177" DRILL
C	2 mm WIPE SIGNAL, 2 mm WIPE LG GND, Ø.0217" DRILL
D	2 mm WIPE SIGNAL, 2 mm WIPE LG GND, Ø.0177" DRILL

NUMBER	WALL THICKNESS / SHIELD OPTION
1	THICK WALL, W/O SHIELD

NOTE: ONLY THREE MOST RECENT RELEASED REVISIONS DISPLAYED.

	LETTER								
LEFT POLARIZING GUIDANCE (SEE SHEET 3)	J (NO KEY)	A	B	C	D	E	F	G	H
RIGHT POLARIZING GUIDANCE (SEE SHEET 4)	Y (NO KEY)	P	Q	R	S	T	U	V	W
OPEN (SEE SHEET 2)	O (ZERO)								
LEFT WALL (SEE SHEET 5)	L								
RIGHT WALL (SEE SHEET 6)	M								
TWO WALL (SEE SHEET 7)	1								

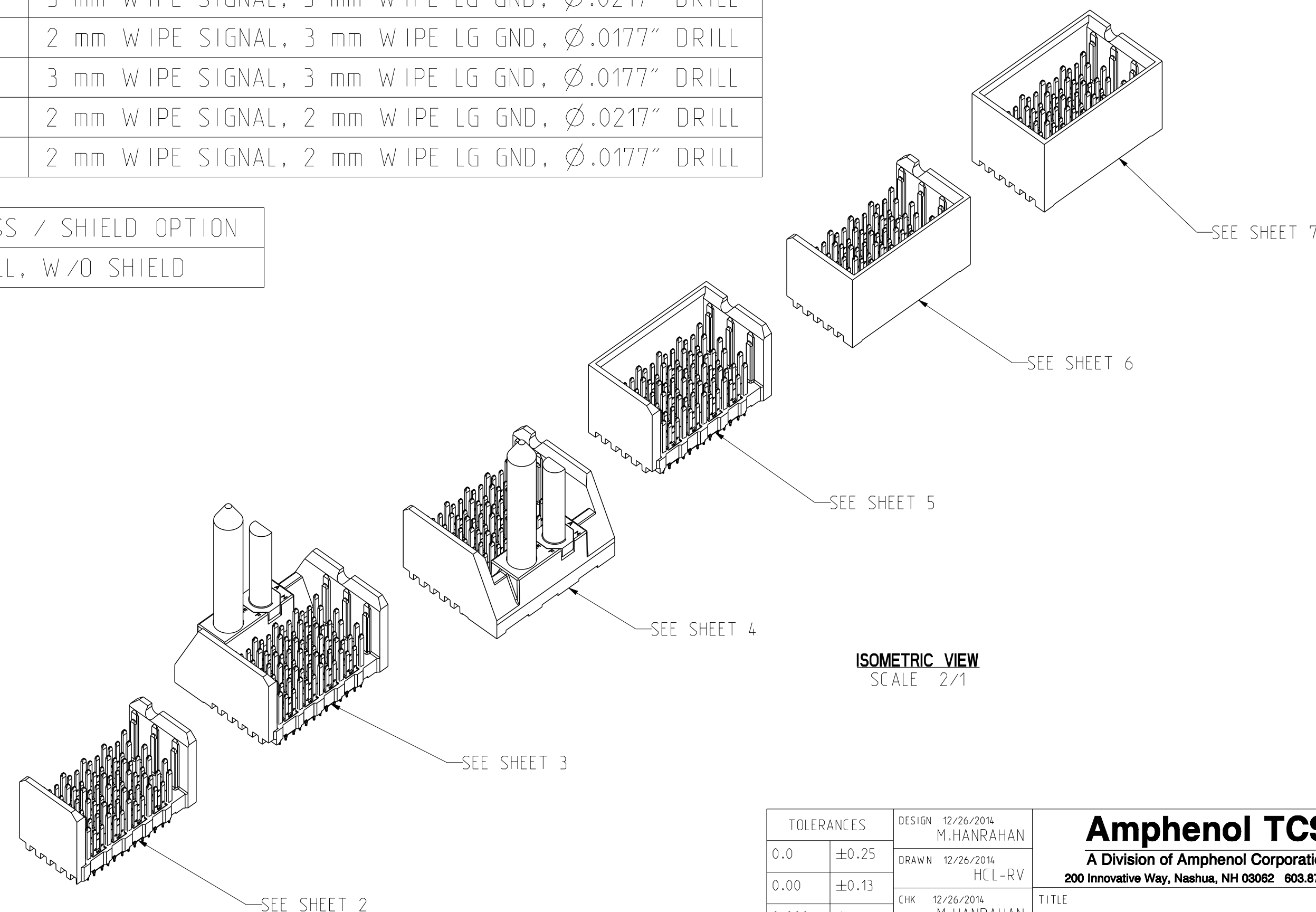

NOTES:

- REFER TO TB-2308 FOR XCede HD PLUS PRODUCT SPECIFICATIONS.
- NOTCH DESIGNATES "ROW A" SIDE OF SHROUD. NOTCH FEATURE ON OPPOSITE SIDE FROM PART MARKING.
- SEE TB-2325 FOR PART MARKING REQUIREMENTS.
- PLATING THICKNESS OF SIGNAL CONTACT AND GROUND CONTACT IS DETERMINED BY PLATING CODE. SEE PART NUMBER TREE SHEET 1.
- REPAIR PROCEDURE FOR MODULE. SEE TB-2245.
- SEE TB-2237 FOR ROUTING GUIDELINES & PTH REQ'S.
- SEE DOC C-190-0009-000 FOR TOOLING KEEPOUT ZONES.
- BACKPLANE DATUM REFERENCE.
- DIMENSIONS APPLY FOR BOTH COMPLIANT PIN SIZES.
- OPTIONAL HOLE/MOUNTING SCREW LOCATION FOR GROUNDED PIN OR ADDITIONAL GUIDE PIN SUPPORT. SEE DRAWING C914-4010-000 FOR OPTIONAL HOLE DETAILS. ONLY APPLIES FOR MACHINED GUIDE PIN APPLICATIONS.
- SURFACE TRACES IN MODULE OUTLINE NOT RECOMMENDED.

TOLERANCES	DESIGN	12/26/2014 M.HANRAHAN	Amphenol TCS A Division of Amphenol Corporation 200 Innovative Way, Nashua, NH 03082 603.879.3000	
0.0	±0.25	DRAWN	12/26/2014 HCL-RV	TITLE BACKPLANE MODULES, VERTICAL MALE HEADER XCede HD PLUS, 4 PAIR 6 POS, THICK WALL WITH EXTRA GROUND
0.00	±0.13	CHK	12/26/2014 M.HANRAHAN	PART NO. SEE PN TREE SHEET 1
0.000	± -	APVD	12/26/2014 M.HANRAHAN	REV D
ANGLES	± 3°	UNLESS OTHERWISE SPECIFIED DIMENSIONS ARE IN MM. DECIMAL MARKER IS A PERIOD.		
INTERPRET PER ASME Y14.5M CODE IDENT 31413		CUSTOMER USE DRAWING		ASSEM: C926-401C-500_XG 0.1 DRAWING: C926-401C-500 0.6
SIZE	D	SCALE	1/1	SHEET 1 OF 9

ZONE	REV	ECN	DESCRIPTION	BY	DATE	APPROVED
			SEE SHEET 1			

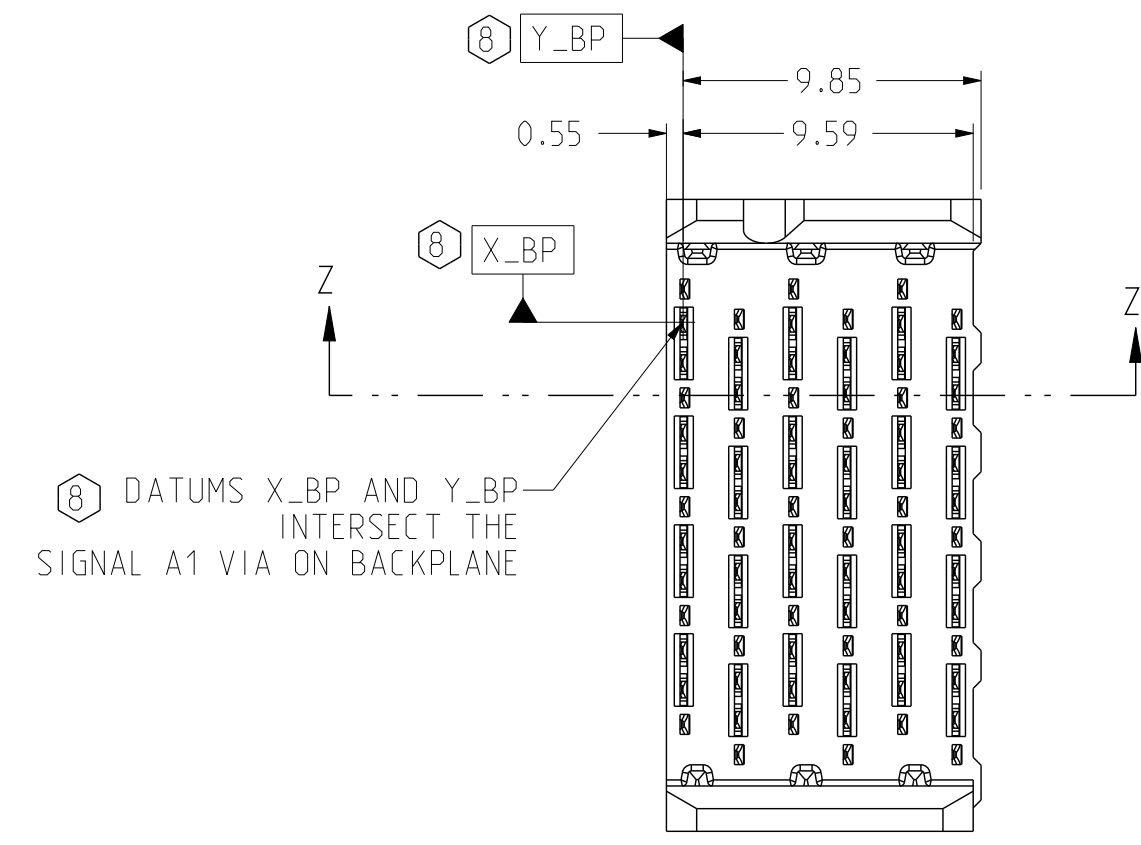

OPEN BACKPLANE MODULE DIMENSION

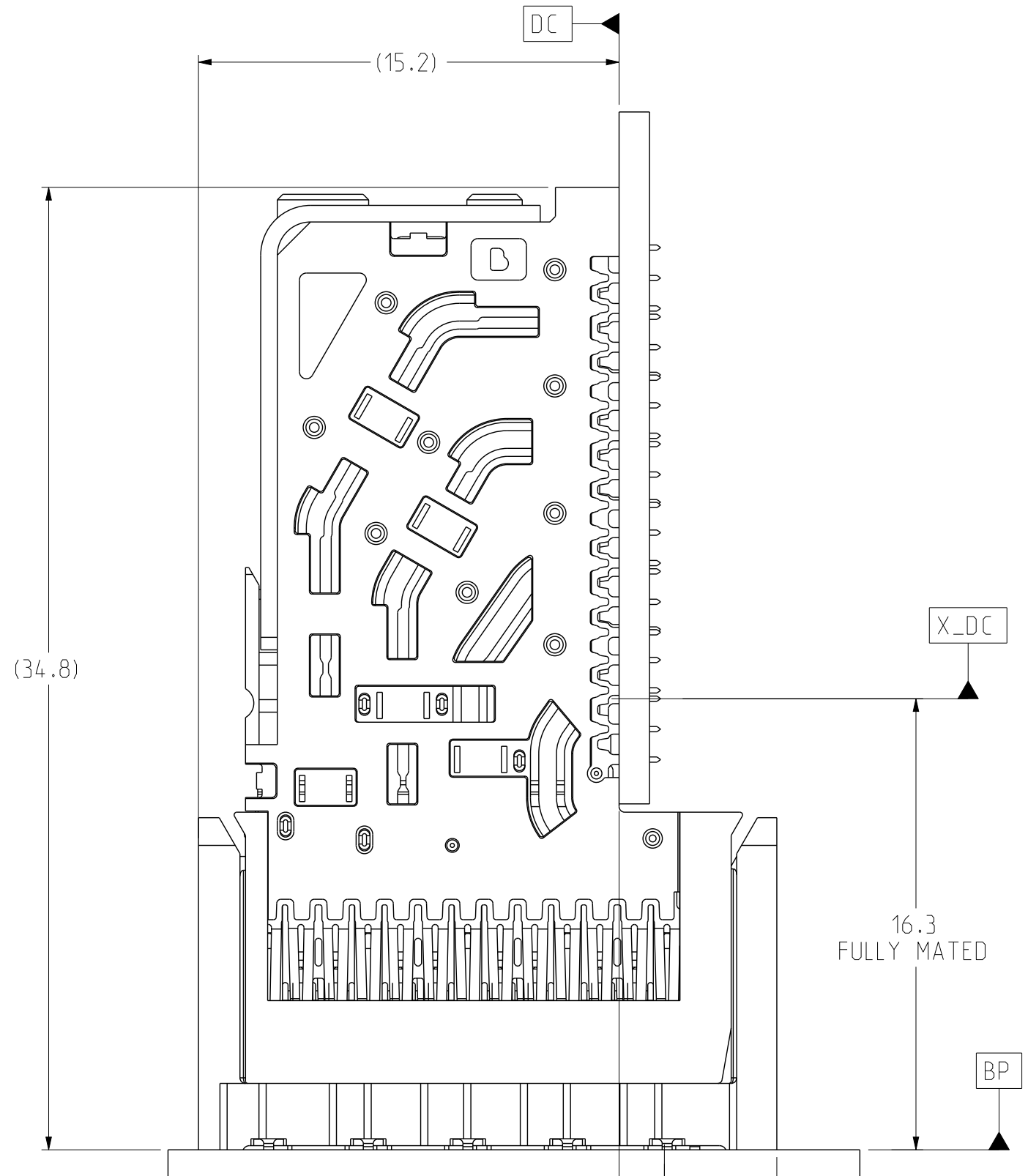

1.64 FROM TOP OF DC PCB TO CL OF ROW A ON BP

CONNECTOR REFERENCE SCALE 5/1

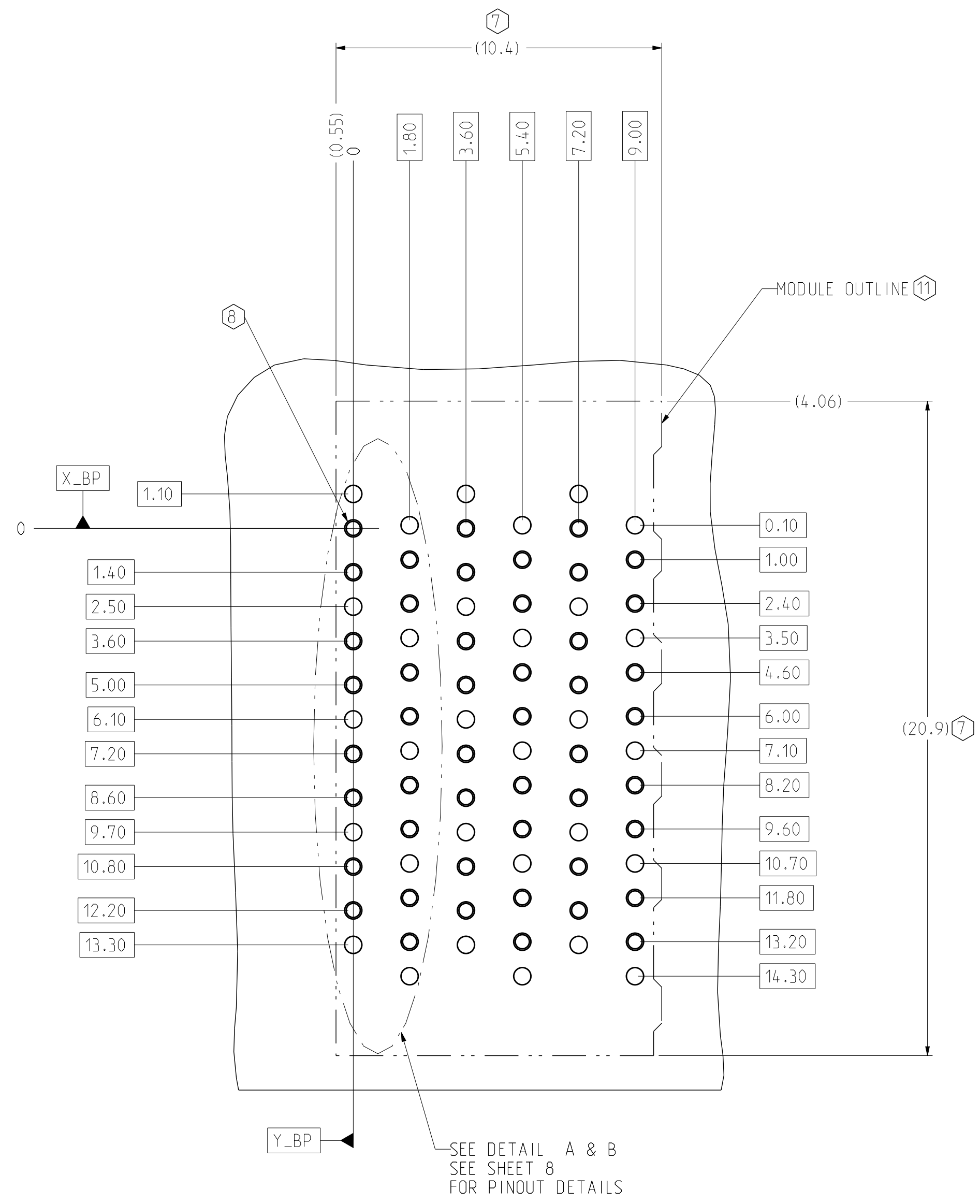
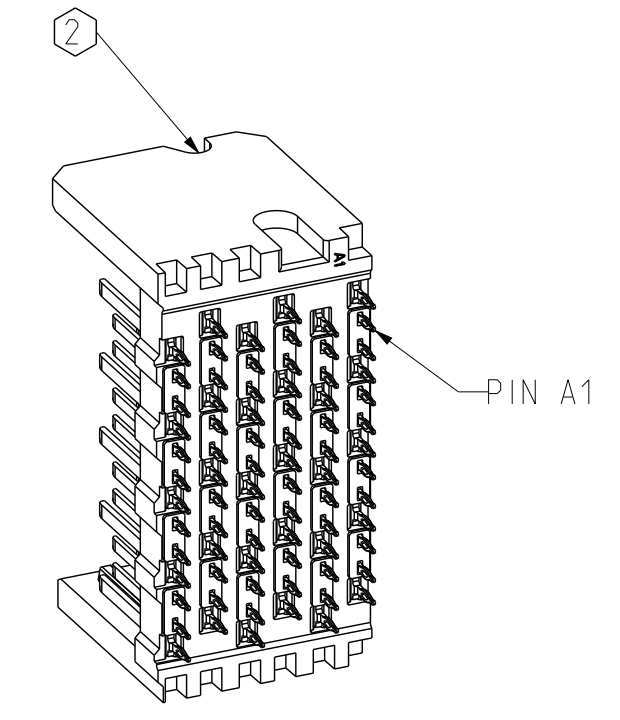
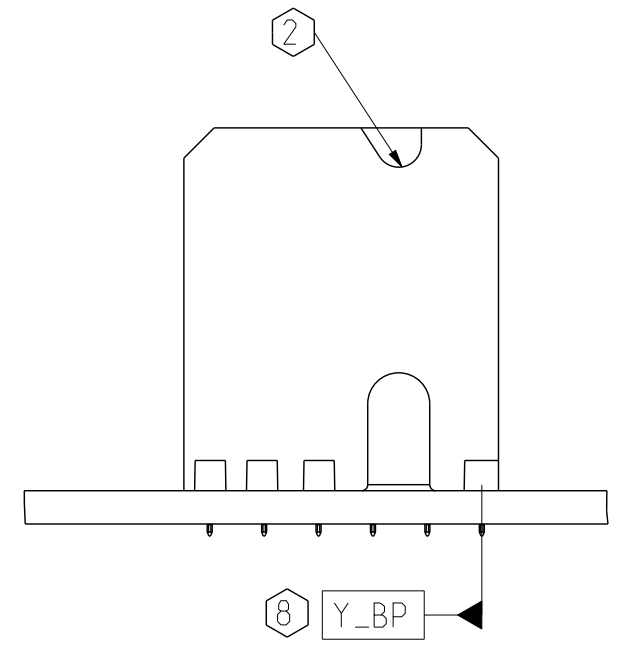
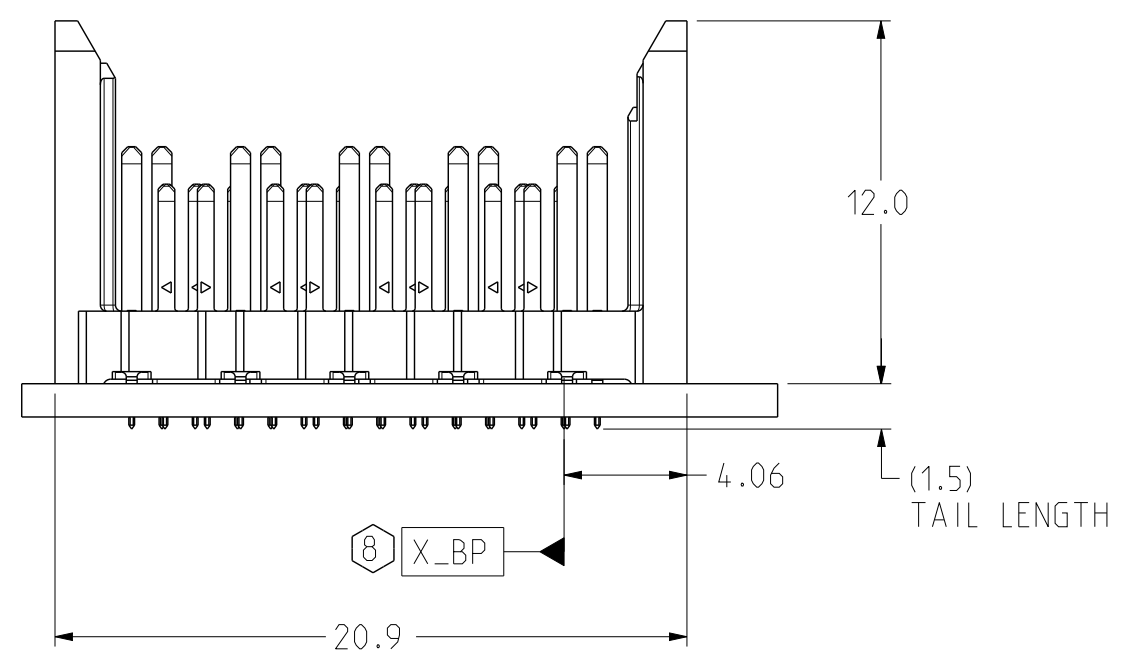
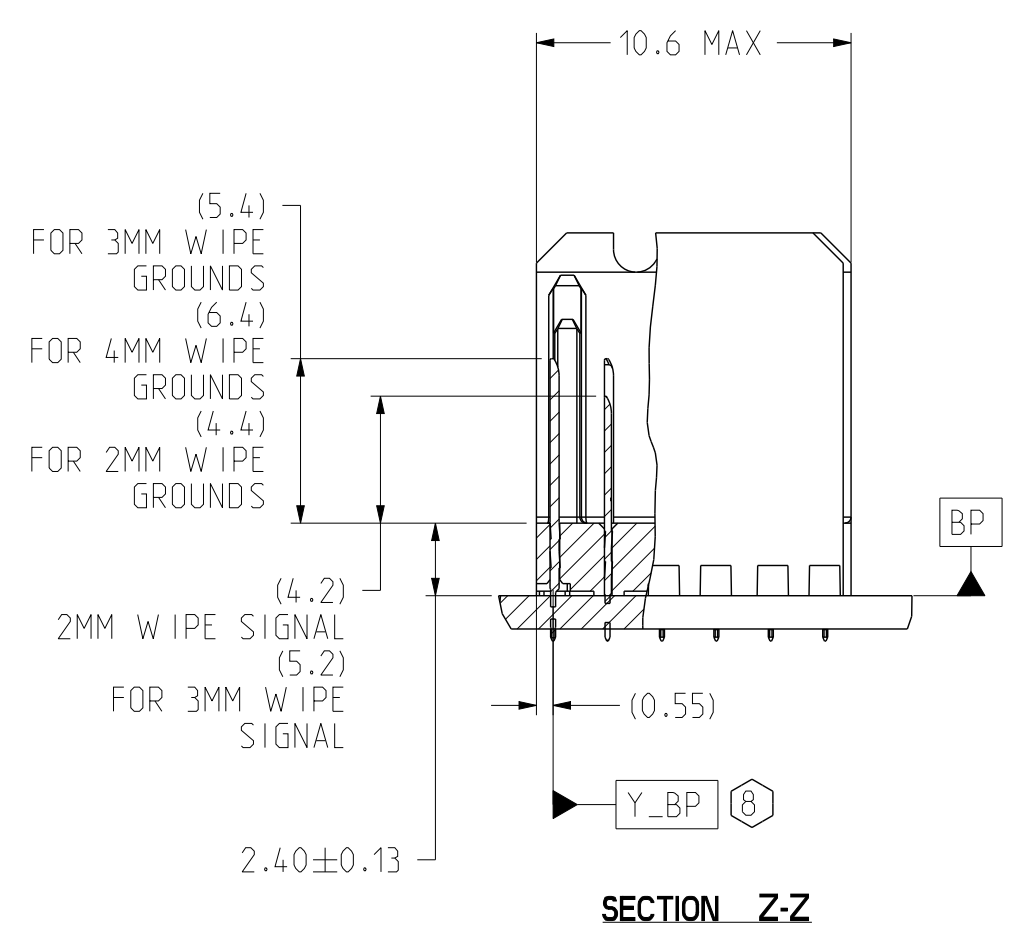

OPEN BACKPLANE FOOTPRINT

TOLERANCES		DESIGN 12/26/2014 M.HANRAHAN	Amphenol TCS A Division of Amphenol Corporation 200 Innovative Way, Nashua, NH 03062 603.879.3000
0.0	±0.25	DRAWN 12/26/2014 HCL-RV	
0.00	±0.13	CHK 12/26/2014 M.HANRAHAN	
0.000	± -	APVD 12/26/2014 M.HANRAHAN	
ANGLES ± 3°		TITLE BACKPLANE MODULES, VERTICAL MALE HEADER XREF: HD PLUS, 4 PAIR @ POS. THICK WALL WITH EXTRA GROUND	
UNLESS OTHERWISE SPECIFIED DIMENSIONS ARE IN MM. DECIMAL MARKER IS A PERIOD.		PART NO. SEE PN TREE SHEET 1	REV N/A
DRAWING NO. C-926-401C-500		REV D	
ASSEM: C926-401C-500_XG 0.0		DRAWING: C926-401C-500 0.6	
SIZE D	SCALE 1/1	SHEET 2 OF 9	

INTERPRET PER ASME Y14.5M
CODE IDENT 31413

CUSTOMER USE
DRAWING

ZONE	REV	ECN	DESCRIPTION	BY	DATE	APPROVED
			SEE SHEET 1			

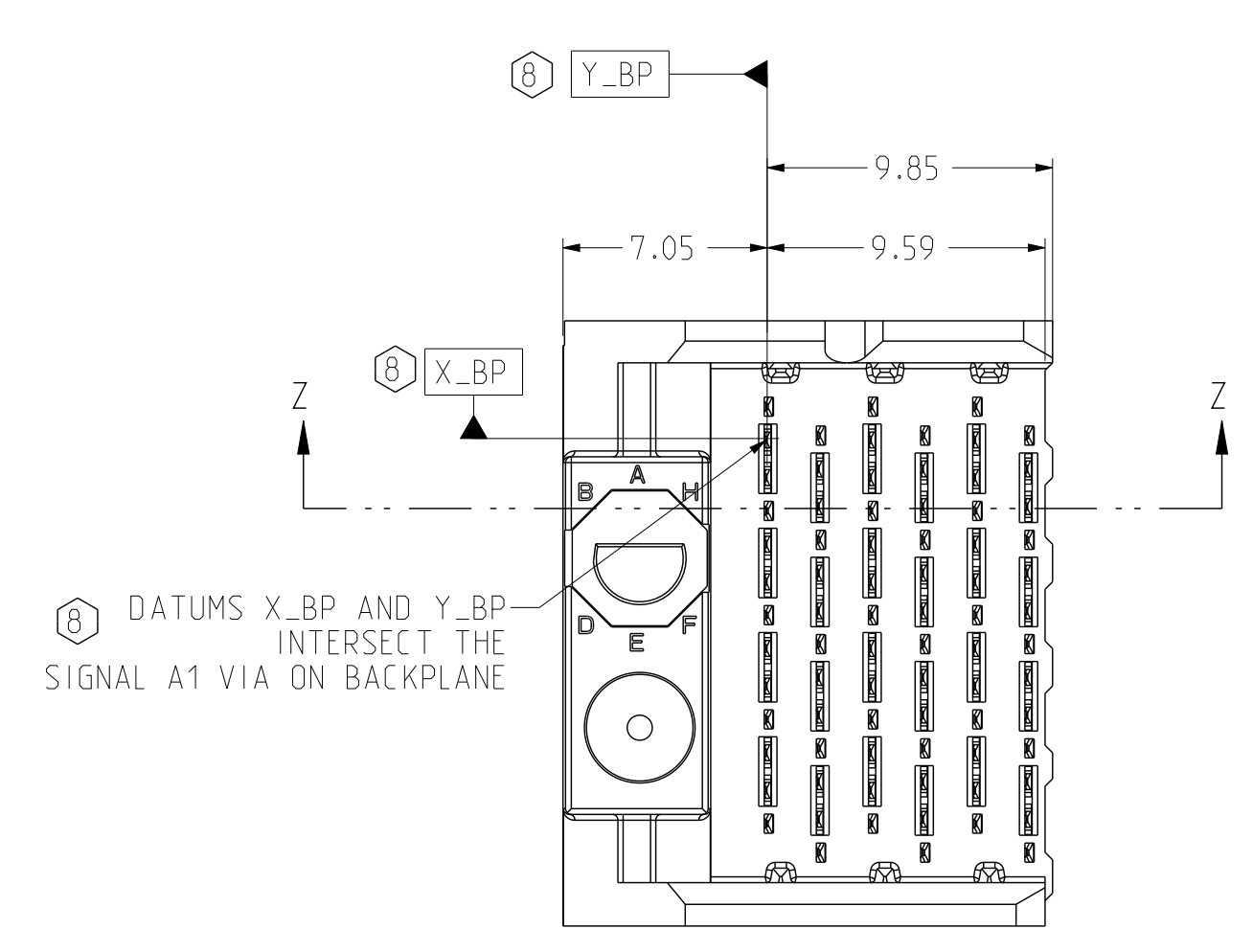

LEFT POLARIZING/GUIDE BACKPLANE MODULE DIMENSION

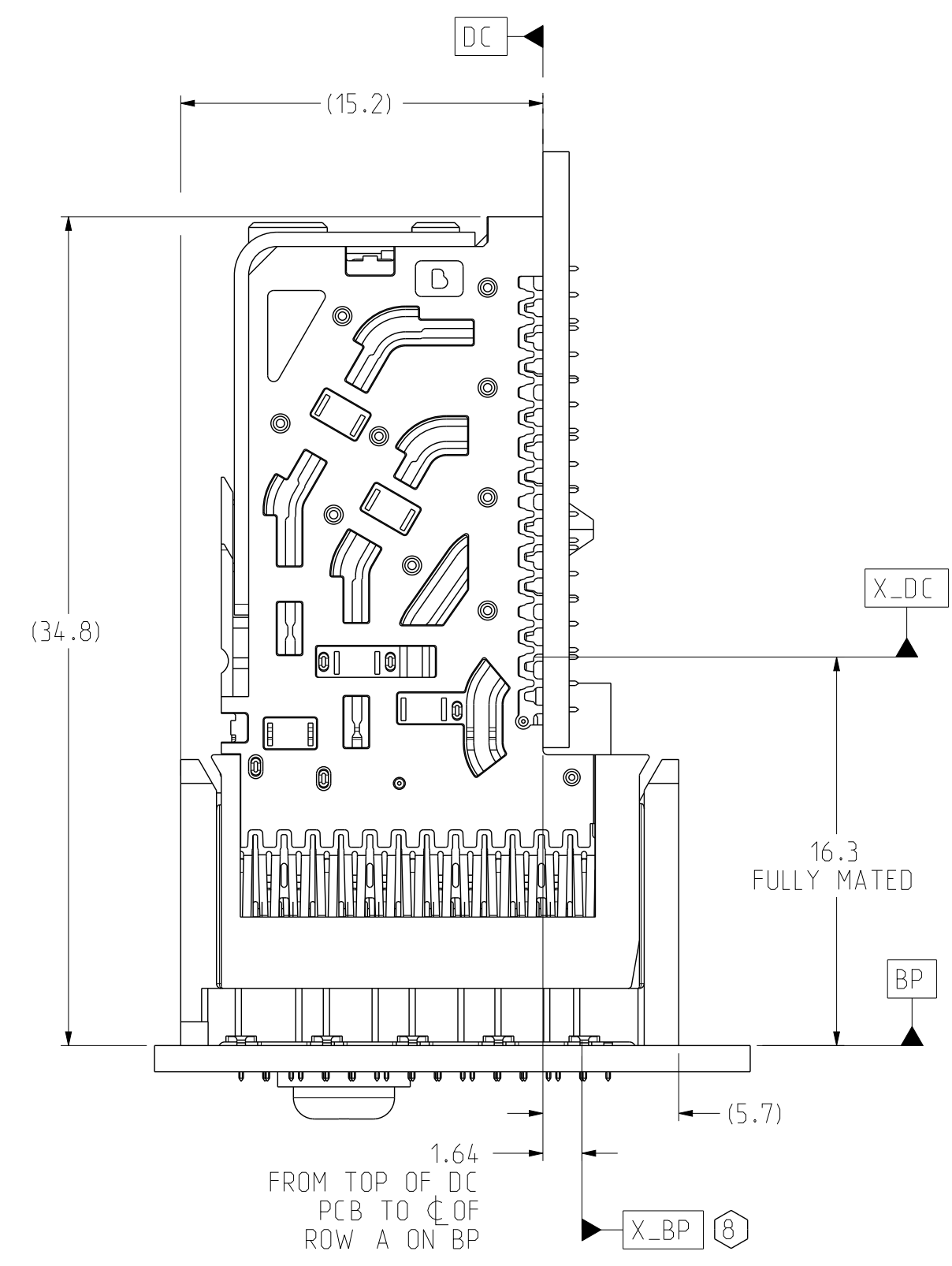

CONNECTOR REFERENCE SCALE 4/1

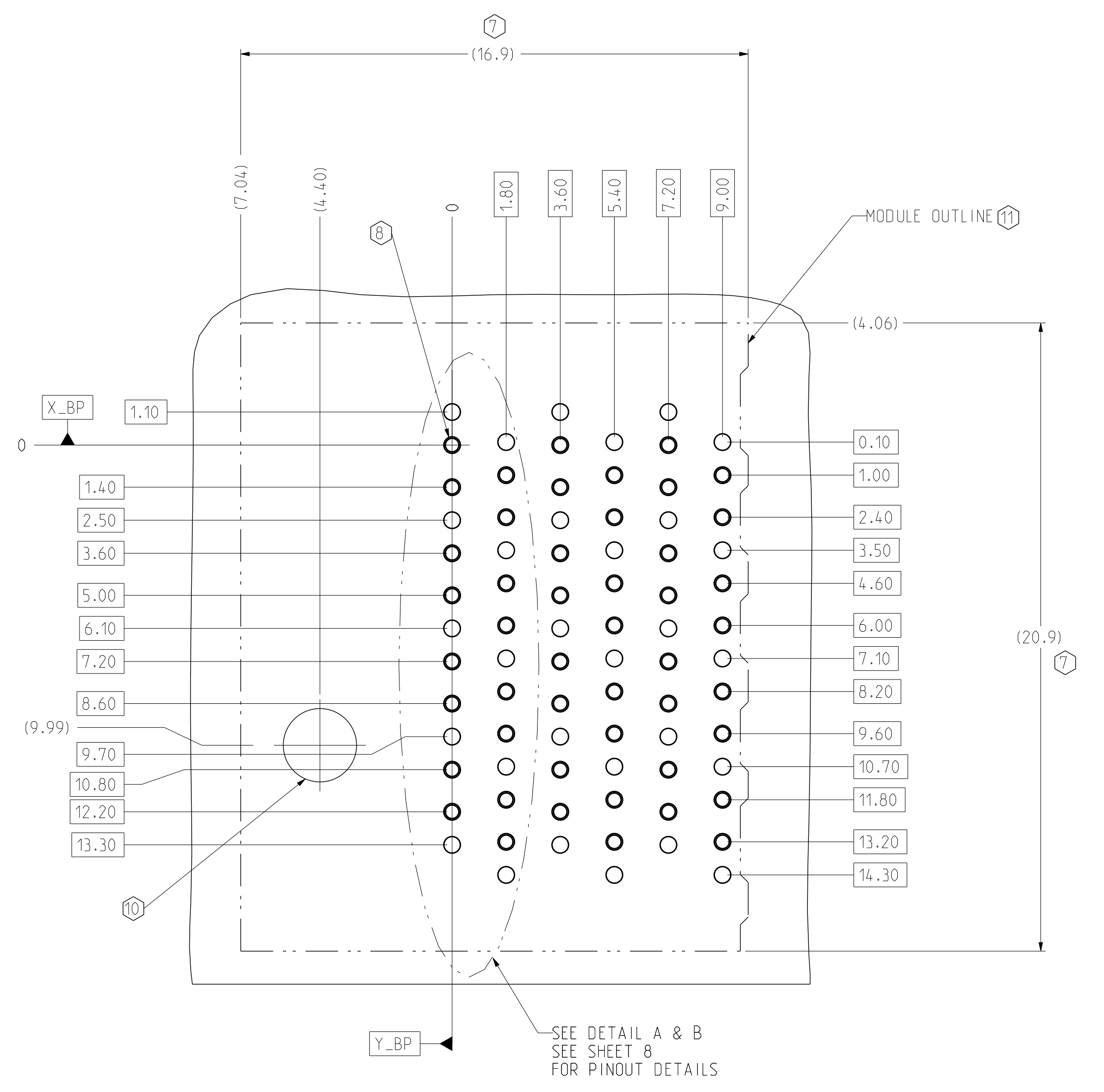

BP HOLE PATTERN COMPONENT SIDE SCALE 8/1

LEFT POLARIZING/GUIDE BACKPLANE FOOTPRINT

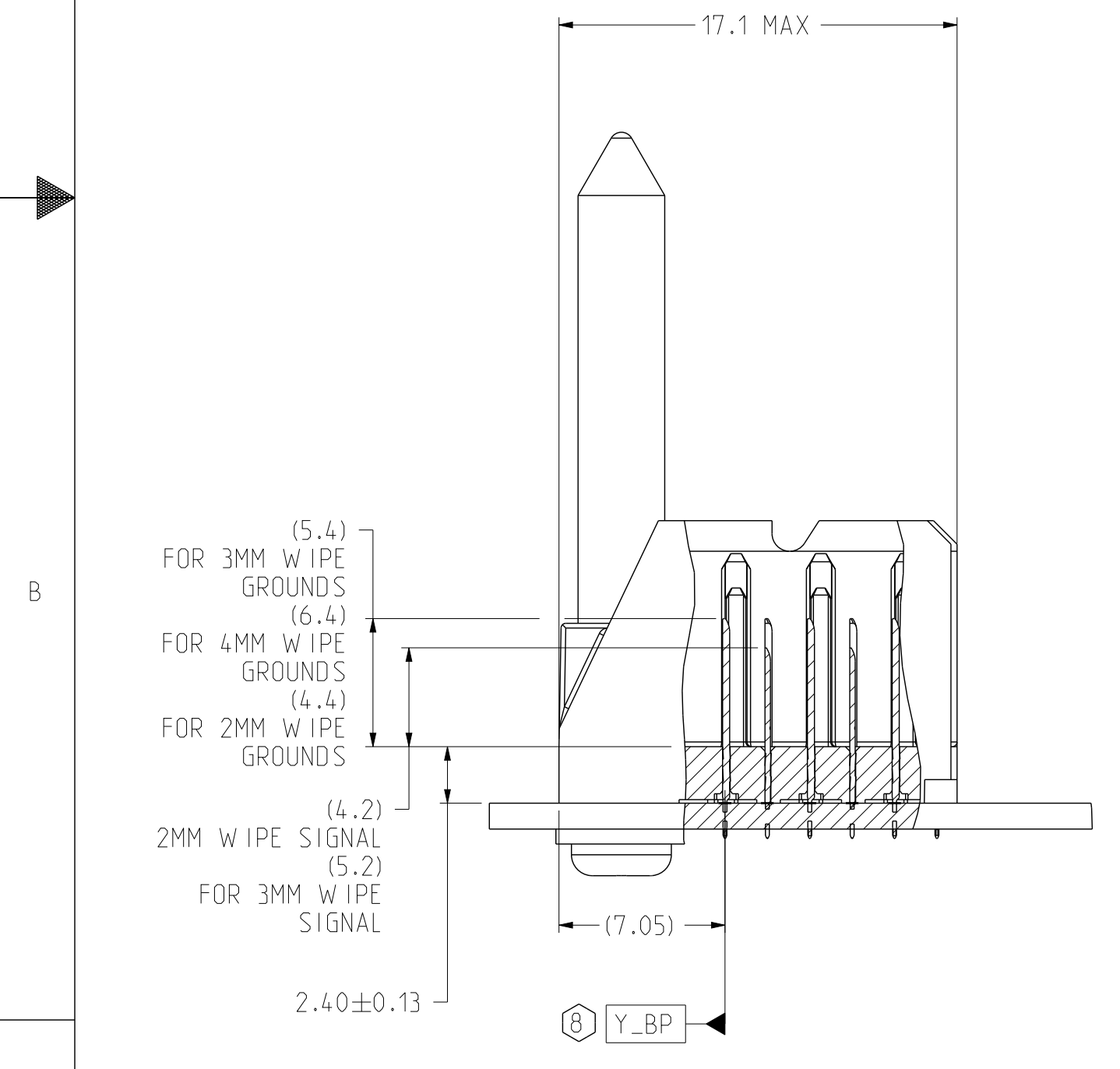

SECTION Z-Z

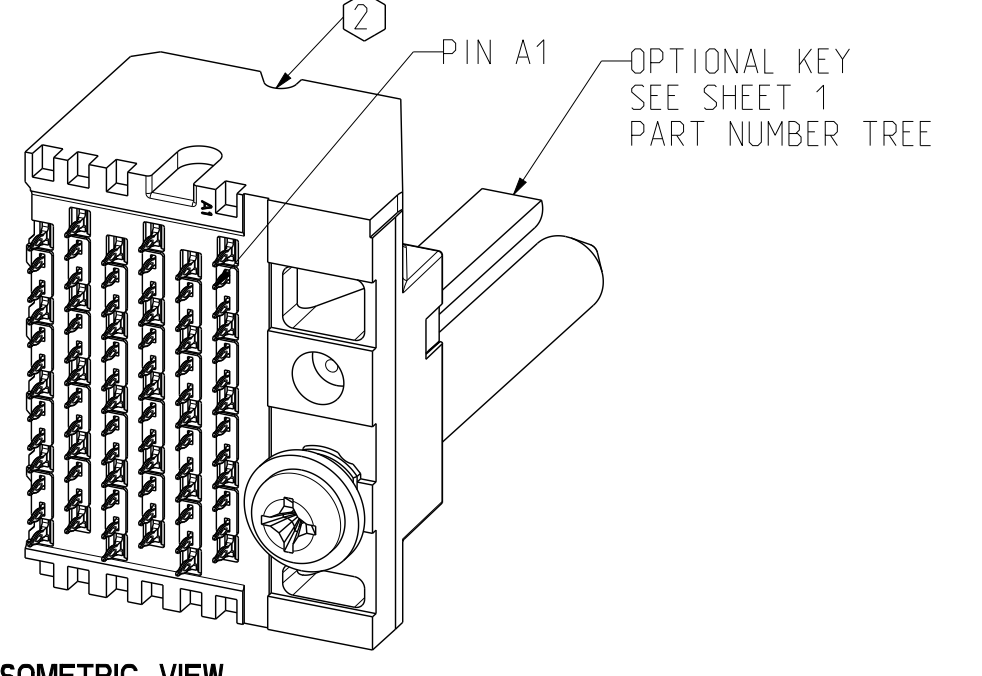
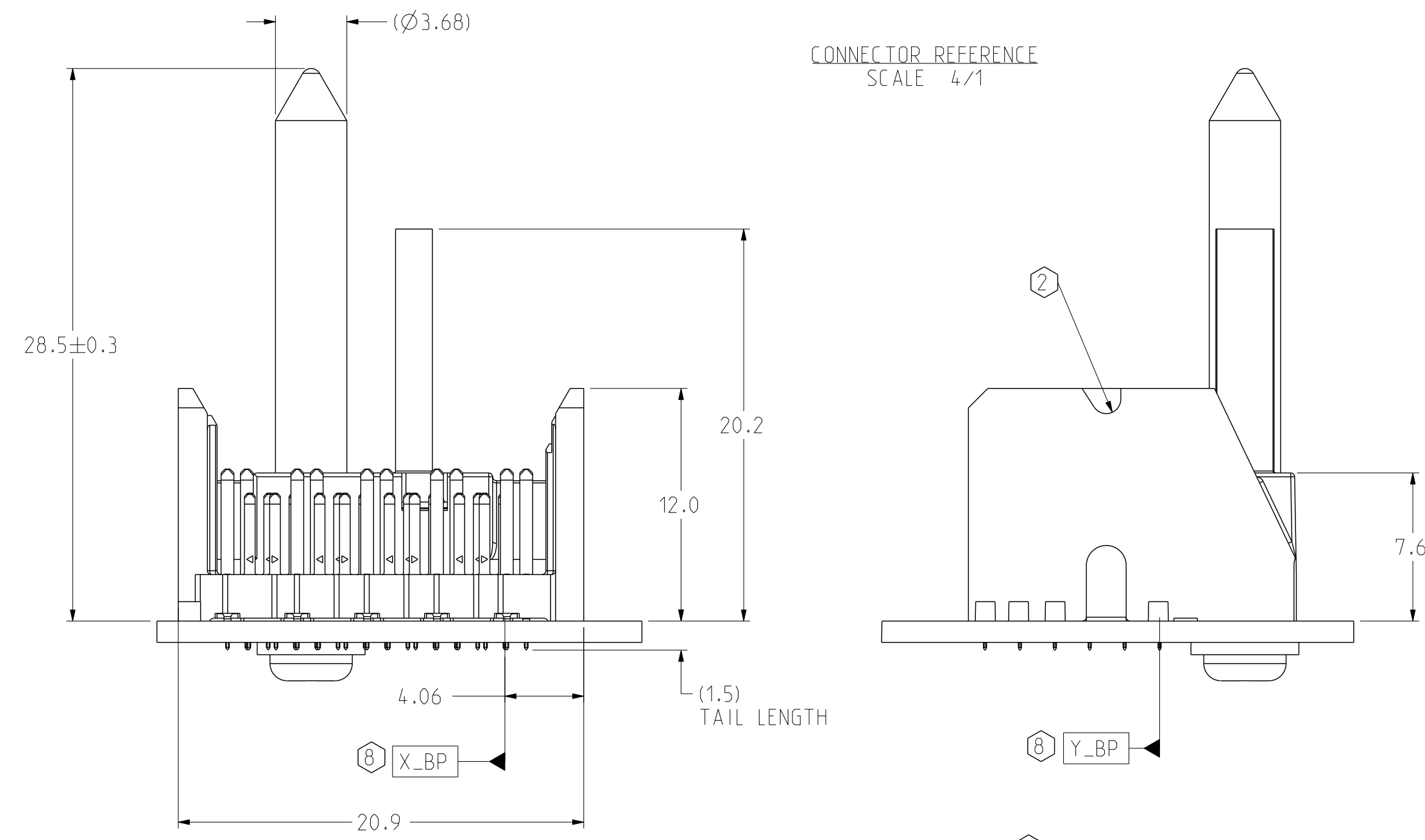

ISOMETRIC VIEW SCALE 3/1

TOLERANCES		DESIGN	Amphenol TCS	
0.0	±0.25	12/26/2014	A Division of Amphenol Corporation	
0.00	±0.13	M.HANRAHAN	200 Innovative Way, Nashua, NH 03062 603.879.3000	
0.000	± -	12/26/2014	TITLE	
ANGLES	± 3°	M.HANRAHAN	BACKPLANE MODULES, VERTICAL MALE HEADER	
UNLESS OTHERWISE SPECIFIED DIMENSIONS ARE IN MM. DECIMAL MARKER IS A PERIOD			X-EDGE HD PLUS, 4 PAIR @ POS. THICK WALL WITH EXTRA GROUND	
DRAWING NO. C-926-401C-500			PART NO. SEE PN TREE SHEET 1	REV N/A
ASSEM: C926-401C-500_XG 0.1			REV D	
DRAWING: C926-401C-500 0.6			SHEET 3 OF 9	

INTERPRET PER ASME Y14.5M
CODE IDENT 31413

CUSTOMER USE DRAWING

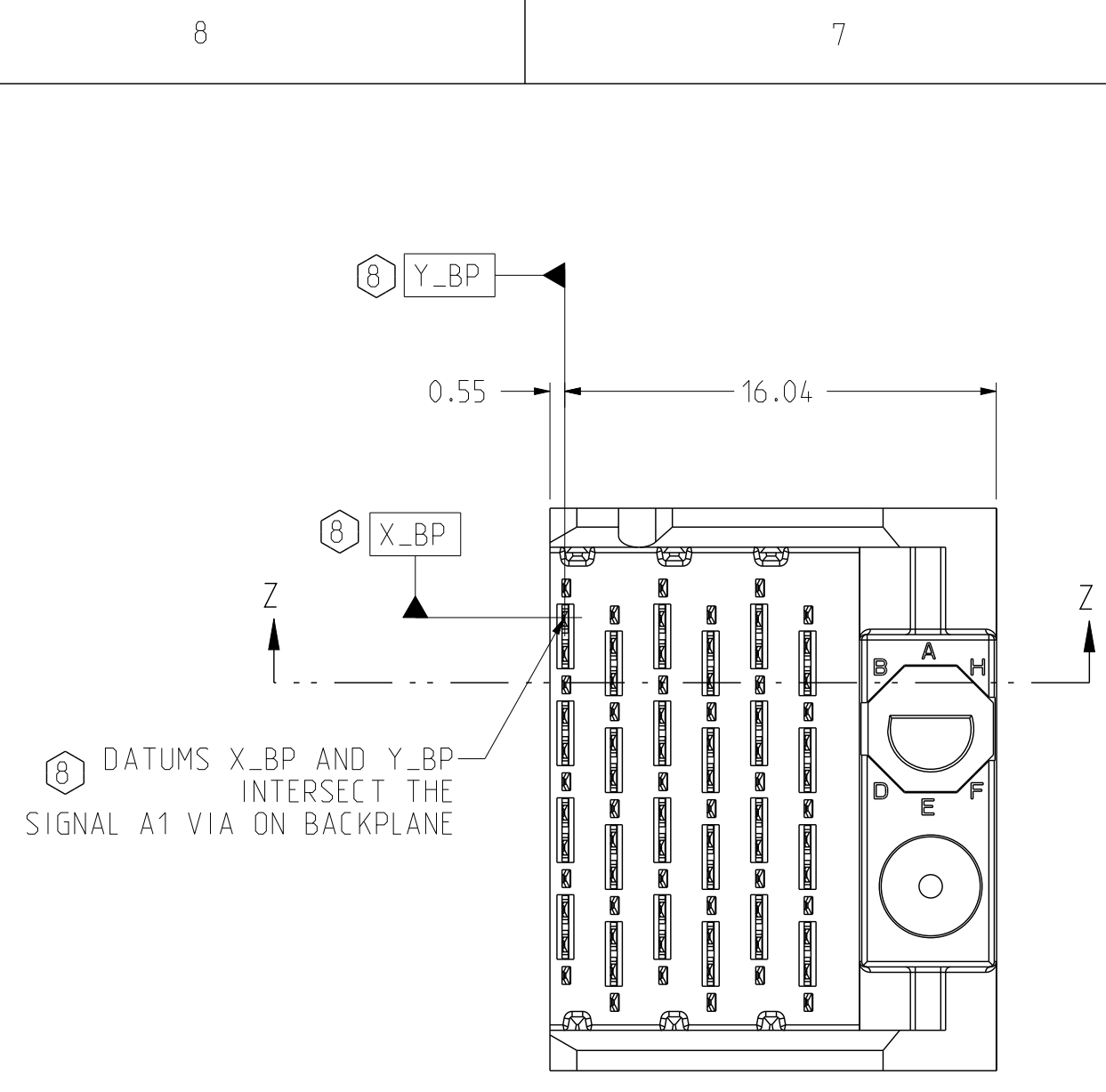

RIGHT POLARIZING/GUIDE
BACKPLANE MODULE DIMENSION

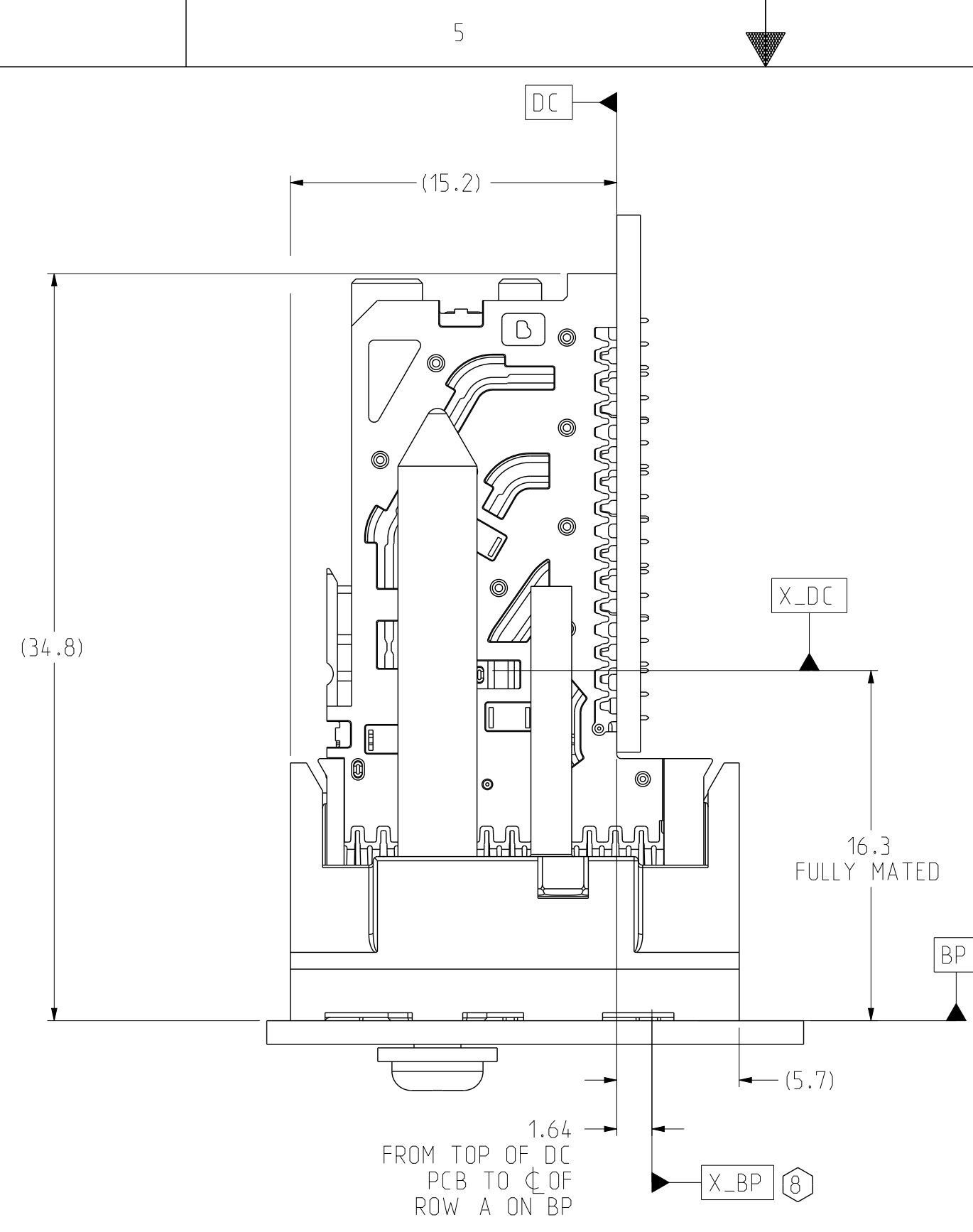

CONNECTOR REFERENCE
SCALE 4/1

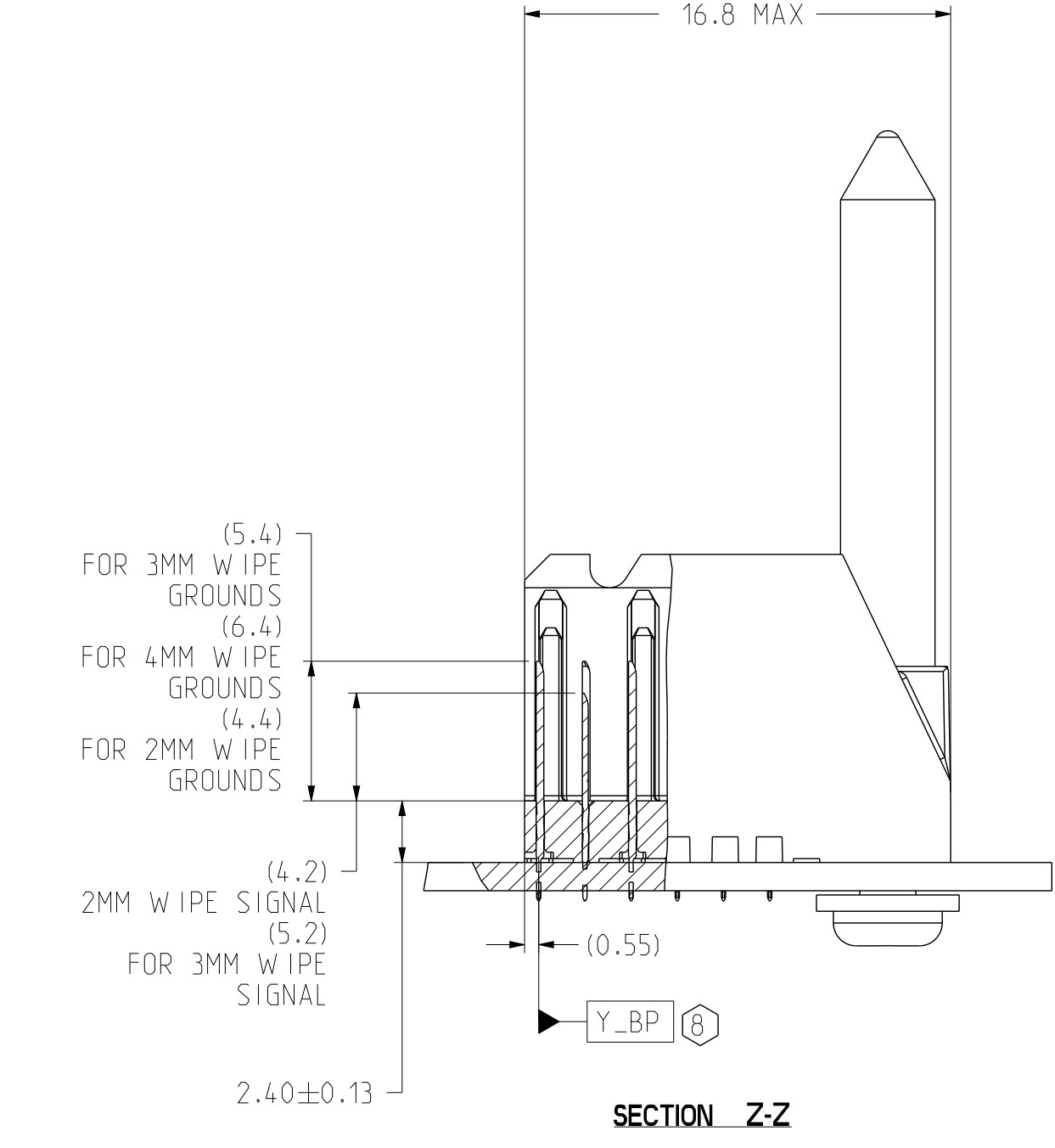

SECTION Z-Z

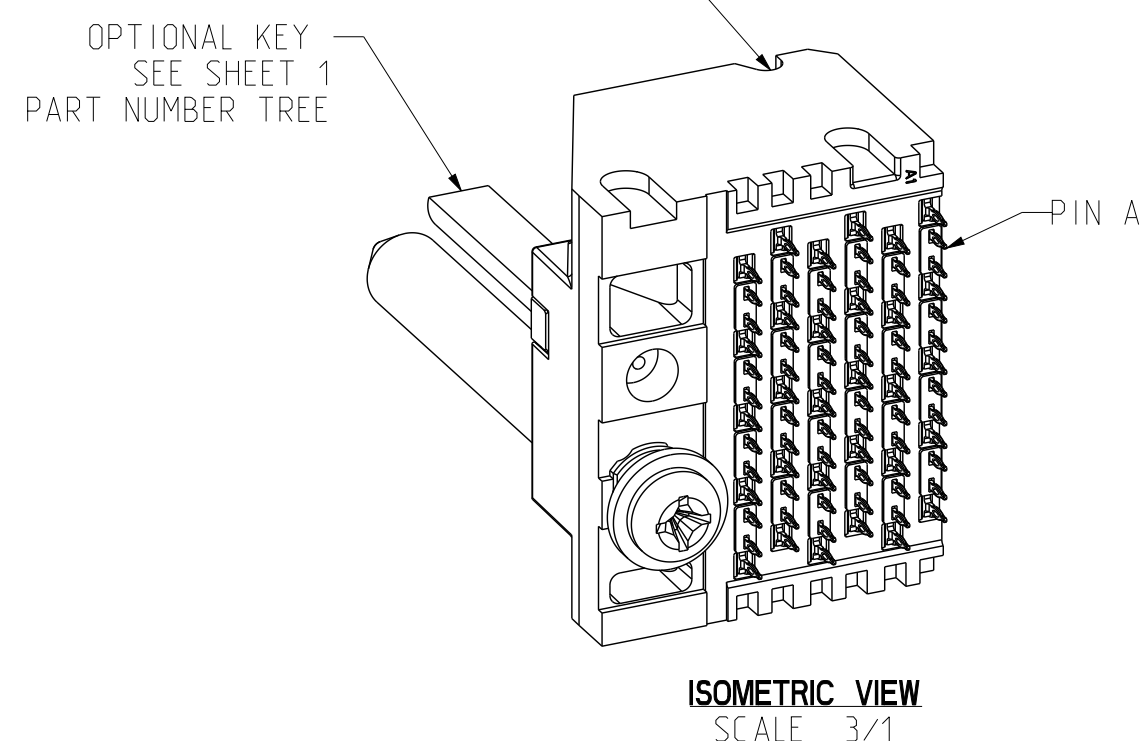
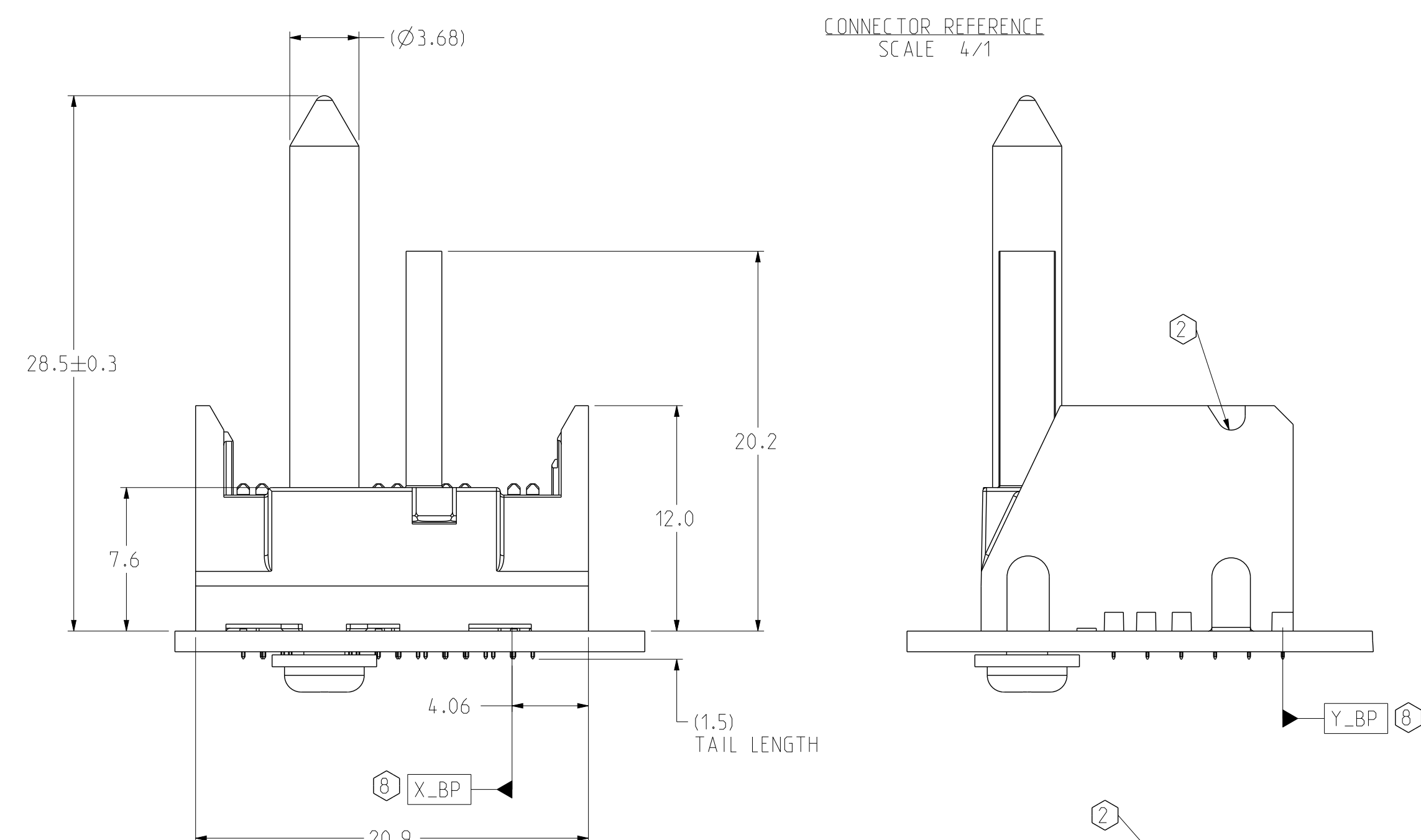

ISOMETRIC VIEW
SCALE 3/1

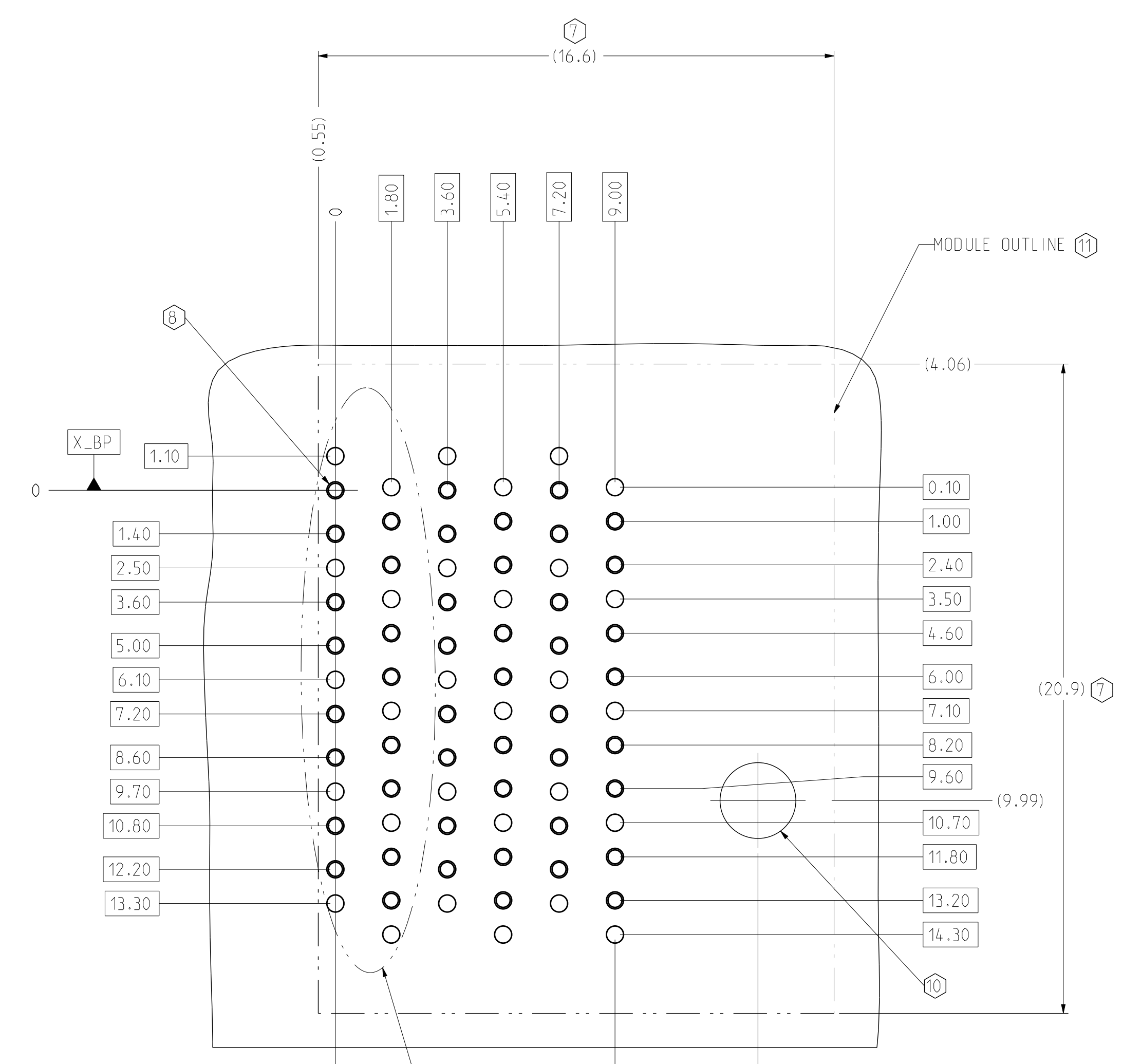

RIGHT POLARIZING/GUIDE
BACKPLANE FOOTPRINT

BP HOLE PATTERN
COMPONENT SIDE
SCALE 8/1

TOLERANCES	DESIGN 12/26/2014 M.HANRAHAN	Amphenol TCS A Division of Amphenol Corporation 200 Innovative Way, Nashua, NH 03062 603.879.3000
0.0 ±0.25	DRAWN 12/26/2014 HCL-RV	
0.00 ±0.13	CHK 12/26/2014 M.HANRAHAN	
0.000 ± -	APVD 12/26/2014 M.HANRAHAN	
ANGLES ± 3°	TITLE BACKPLANE MODULES, VERTICAL MALE HEADER XLEAD HD PLUS, 4 PAIR @ POS. THICK WALL WITH EXTRA GROUND	
UNLESS OTHERWISE SPECIFIED DIMENSIONS ARE IN MM. DECIMAL MARKER IS A PERIOD		PART NO. SEE PN TREE SHEET 1
DRAWING NO. C-926-401C-500		REV D
ASSEM: C926-401C-500_XG 0.1		SCALE 1/1
DRAWING: C926-401C-500 0.6		SHEET 4 OF 9

INTERPRET PER ASME Y14.5M
CODE IDENT 31413

CUSTOMER USE
DRAWING

ZONE	REV	ECN	DESCRIPTION	BY	DATE	APPROVED
			SEE SHEET 1			

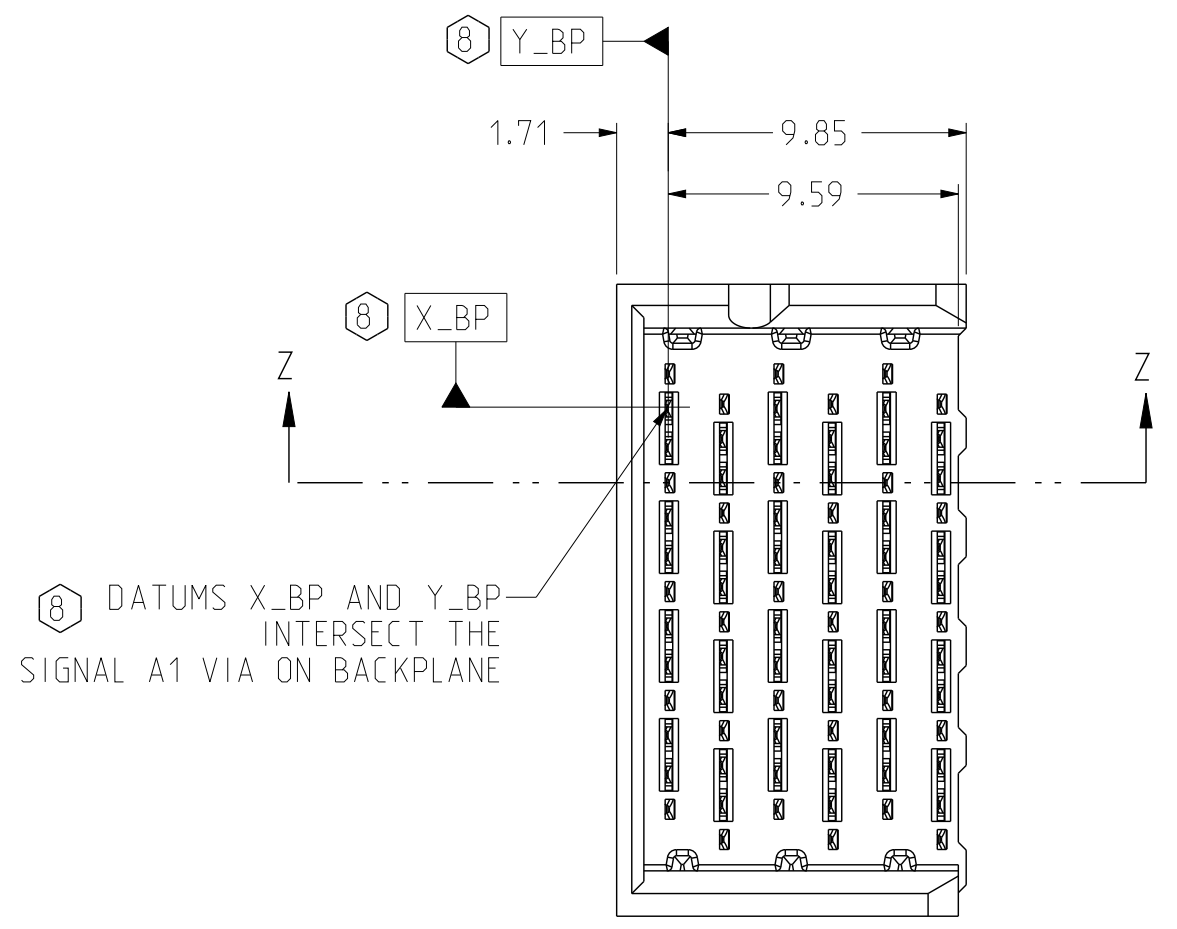

LEFT WALL BACKPLANE MODULE DIMENSION

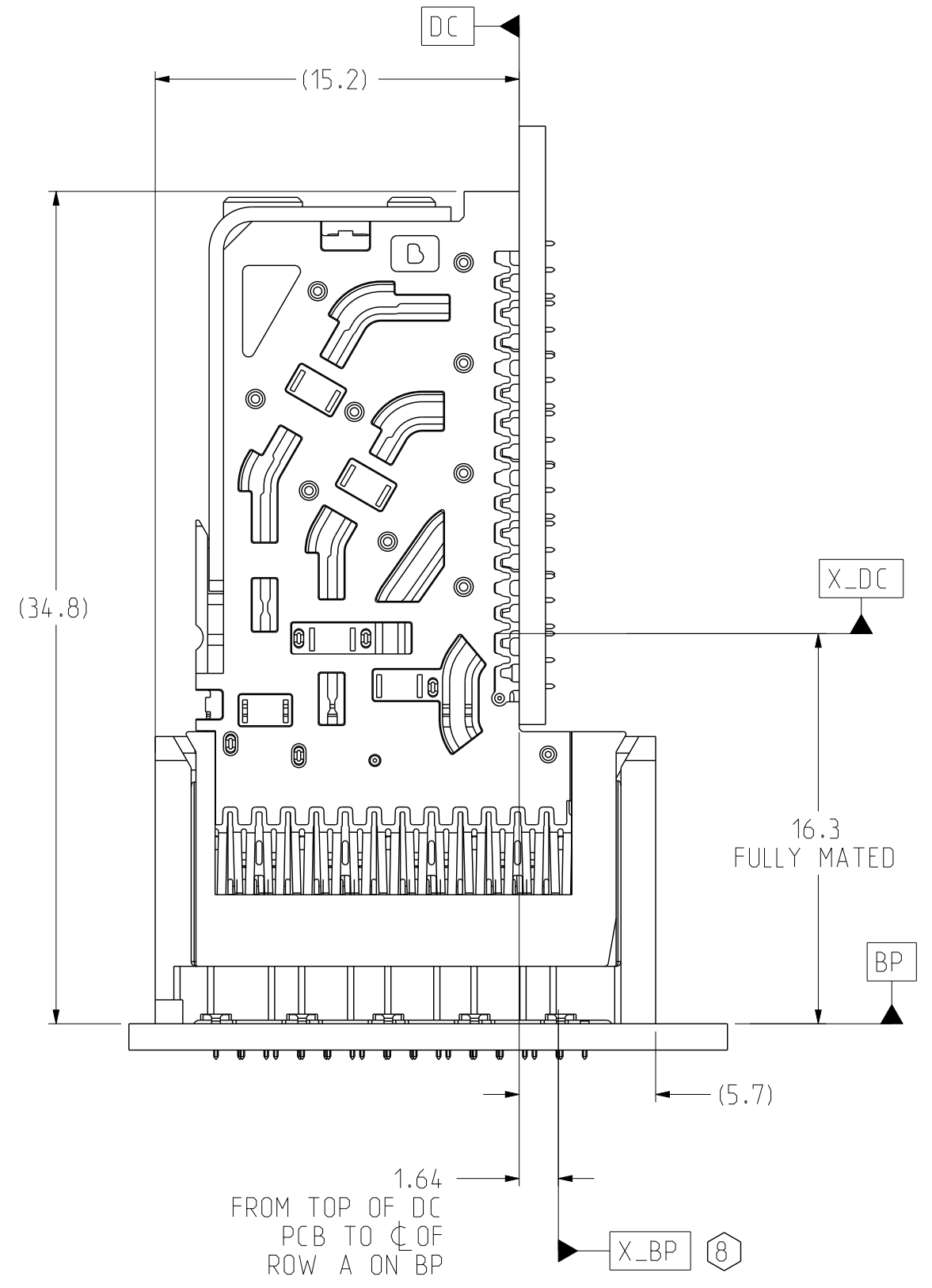

CONNECTOR REFERENCE SCALE 4/1

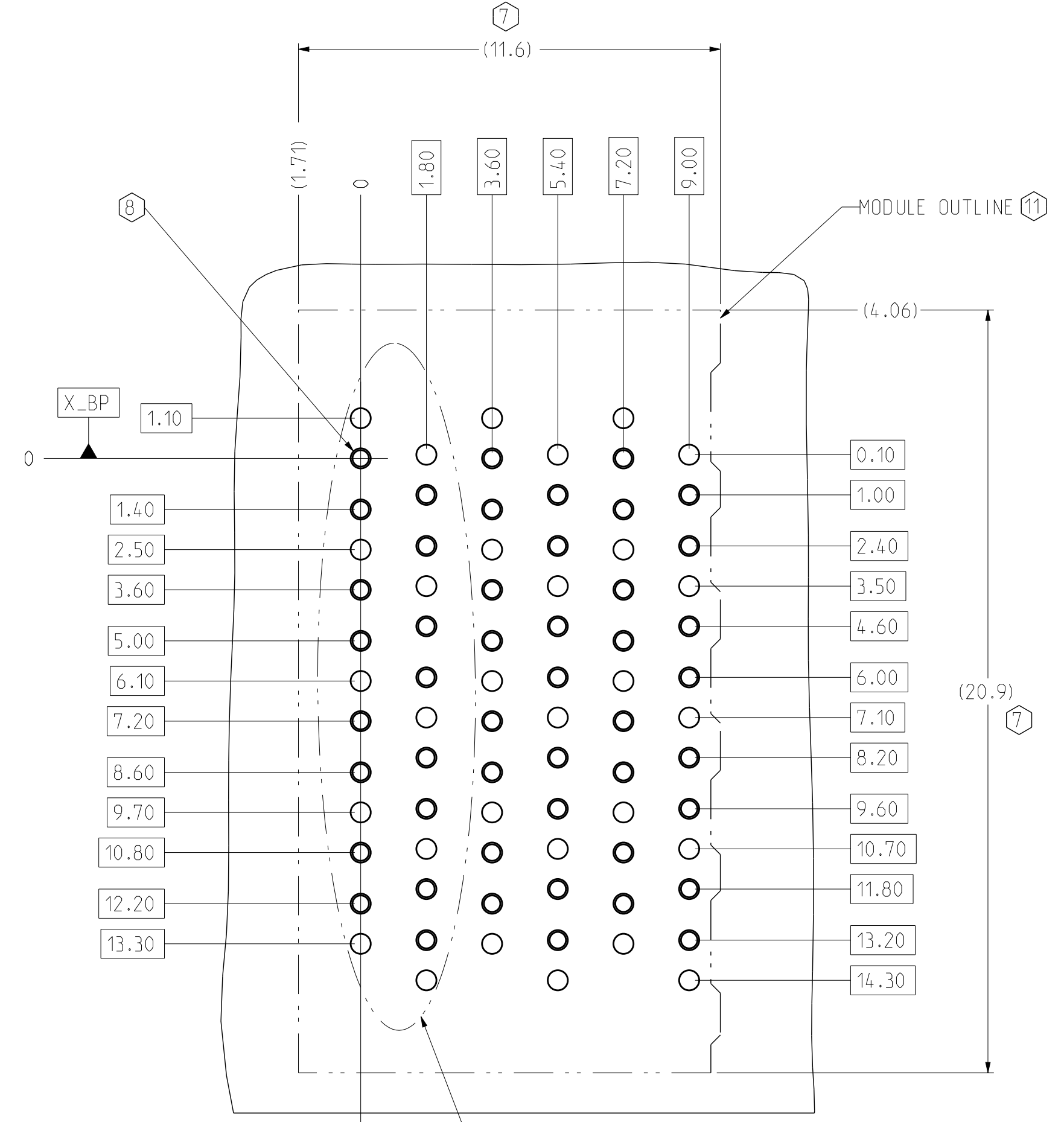

BP HOLE PATTERN COMPONENT SIDE SCALE 8/1

LEFT WALL BACKPLANE FOOTPRINT

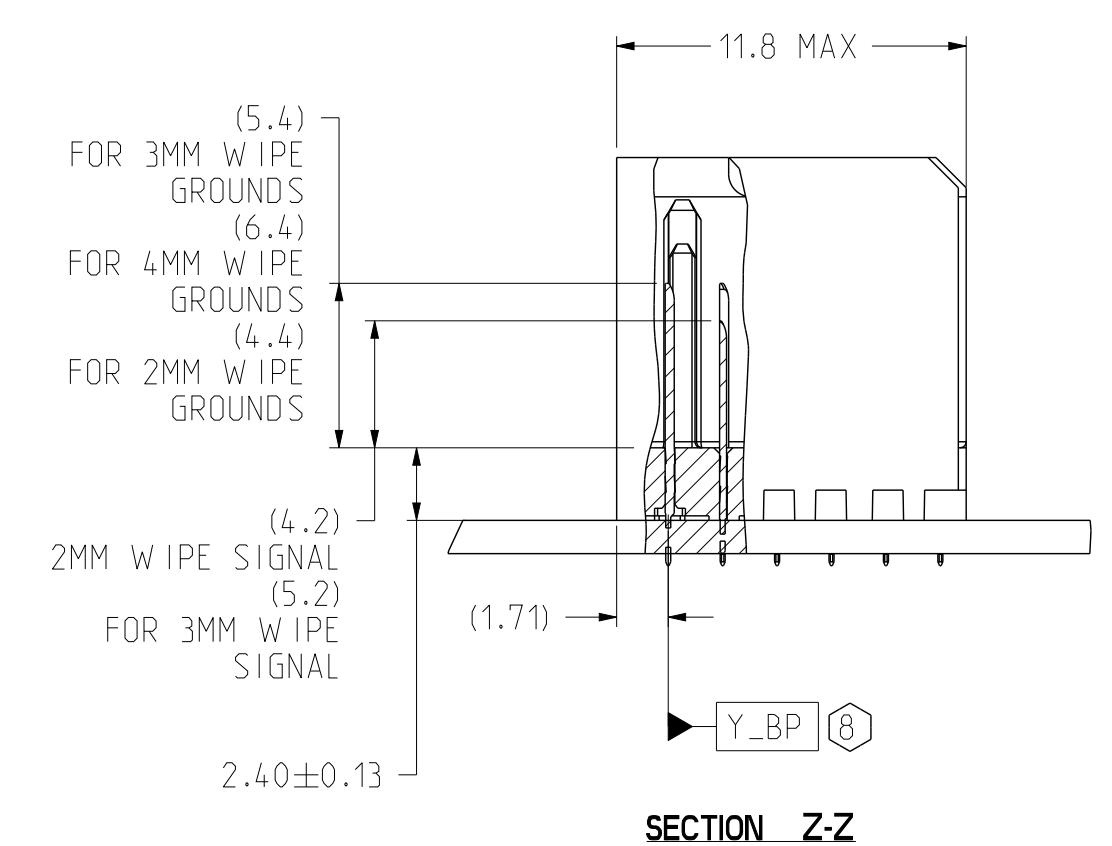

SECTION Z-Z

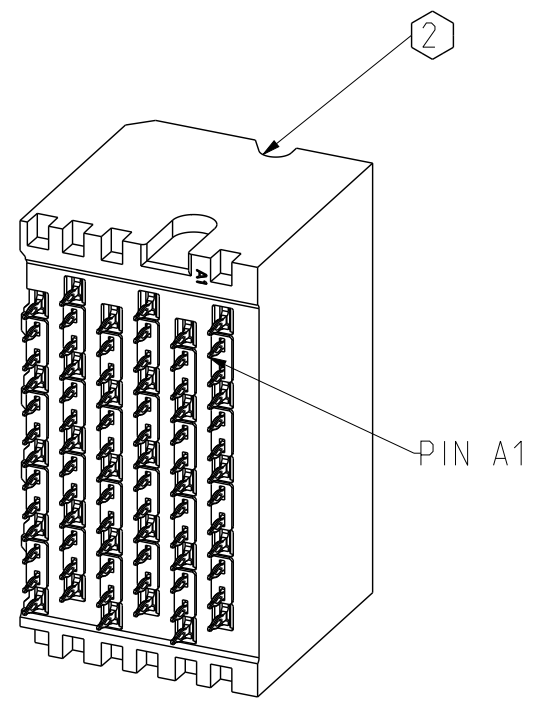
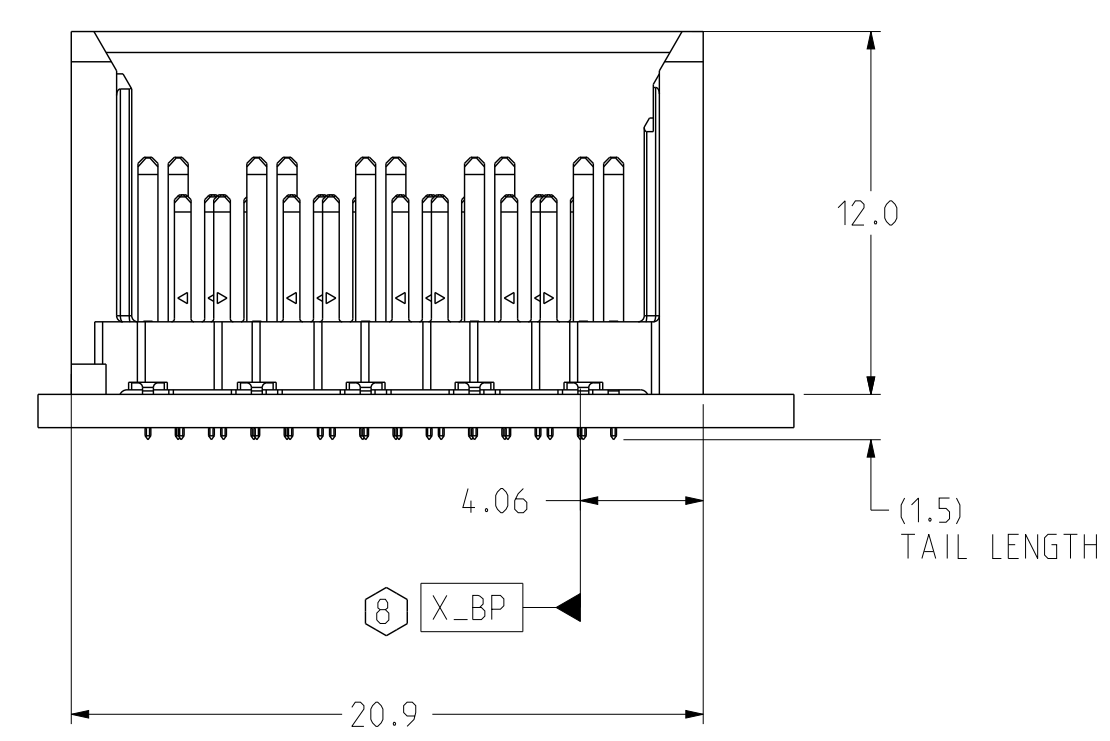

ISOMETRIC VIEW SCALE 3/1

TOLERANCES		DESIGN 12/26/2014 M.HANRAHAN	Amphenol TCS A Division of Amphenol Corporation 200 Innovative Way, Nashua, NH 03062 603.879.3000
0.0	±0.25	DRAWN 12/26/2014 HCL-RV	
0.00	±0.13	CHK 12/26/2014 M.HANRAHAN	
0.000	± -	APVD 12/26/2014 M.HANRAHAN	
ANGLES	± 3°		

UNLESS OTHERWISE SPECIFIED DIMENSIONS ARE IN MM. DECIMAL MARKER IS A PERIOD.		PART NO. SEE PN TREE SHEET 1	REV N/A
DRAWING NO. C-926-401C-500		ASSEM: C926-401C-500_XG 0.0	REV D
DRAWING: C926-401C-500 0.6		SIZE D	SCALE 1/1
		SHEET 5 OF 9	

INTERPRET PER ASME Y14.5M
CODE IDENT 31413

CUSTOMER USE
DRAWING

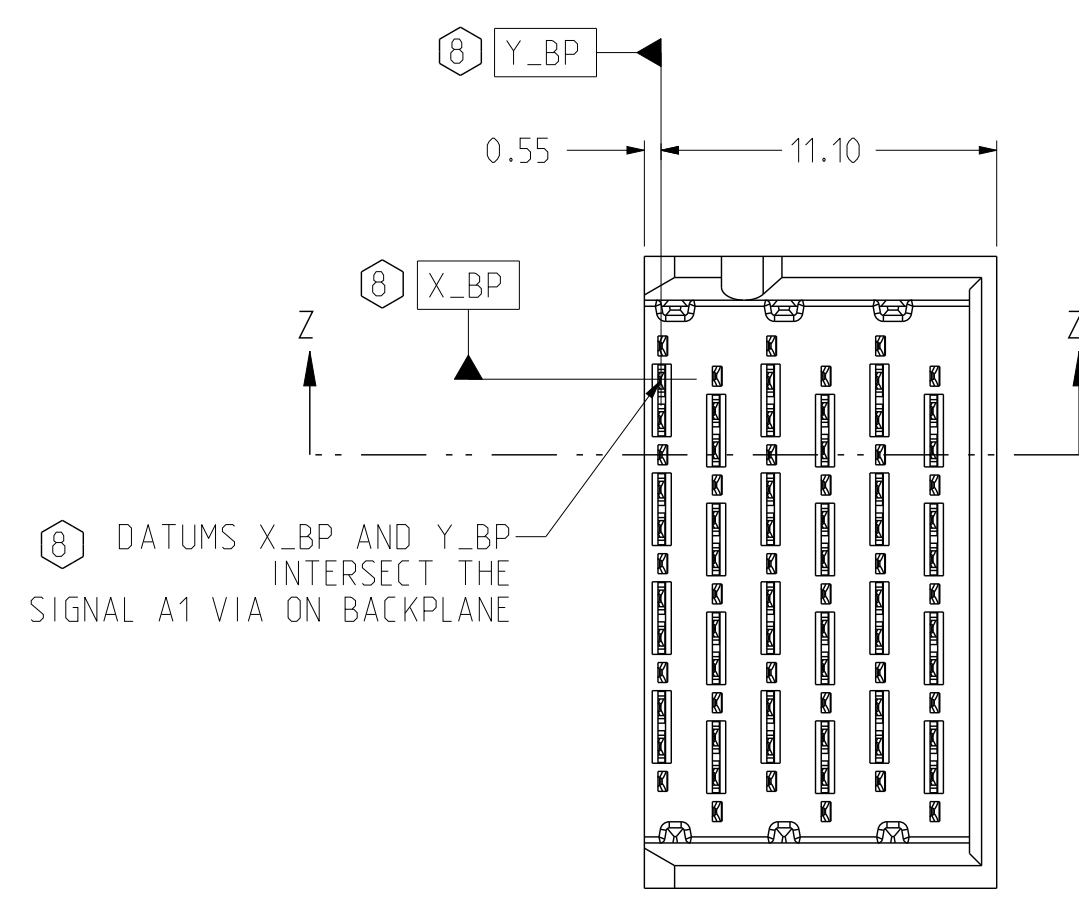

RIGHT WALL BACKPLANE MODULE DIMENSION

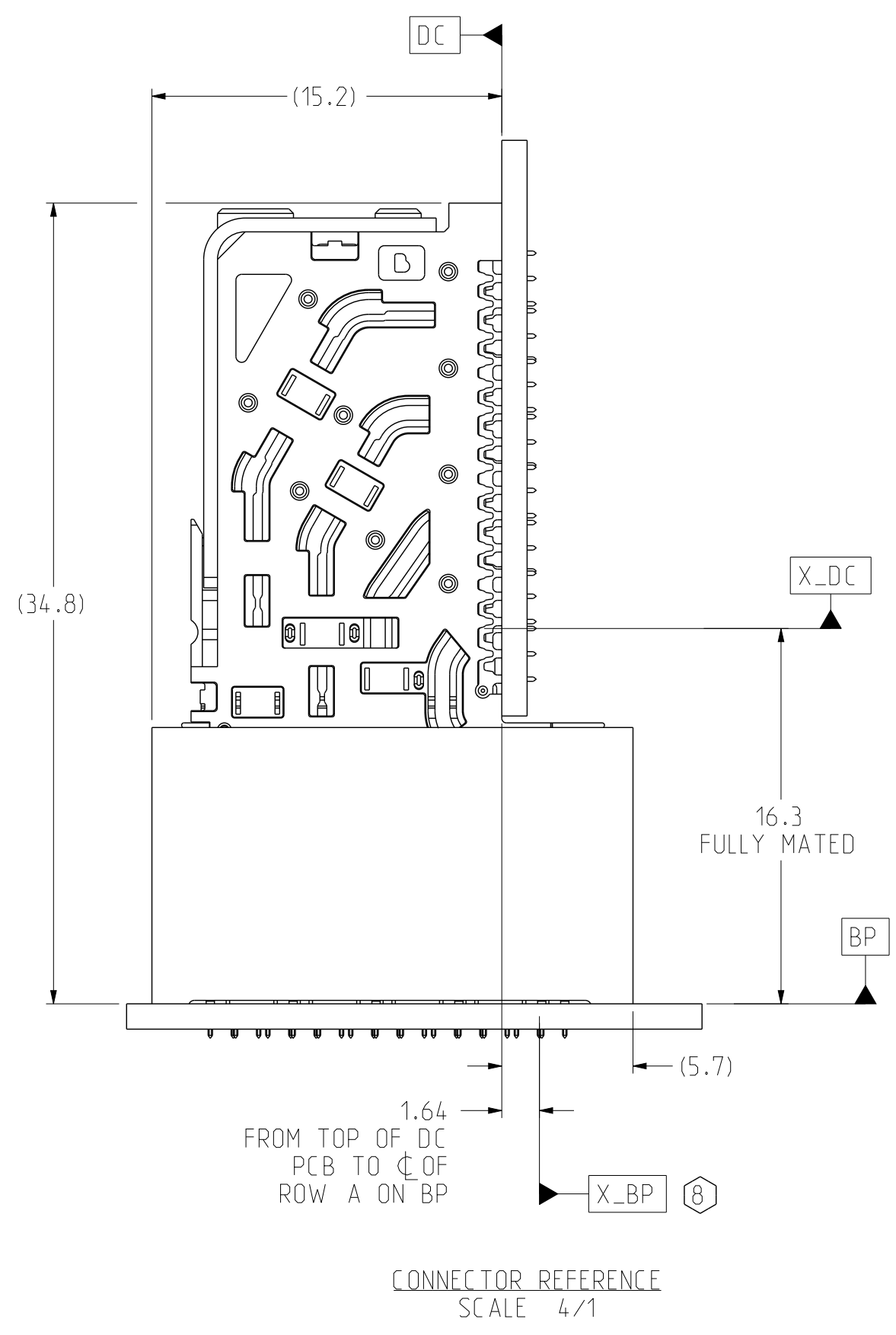

CONNECTOR REFERENCE SCALE 4/1

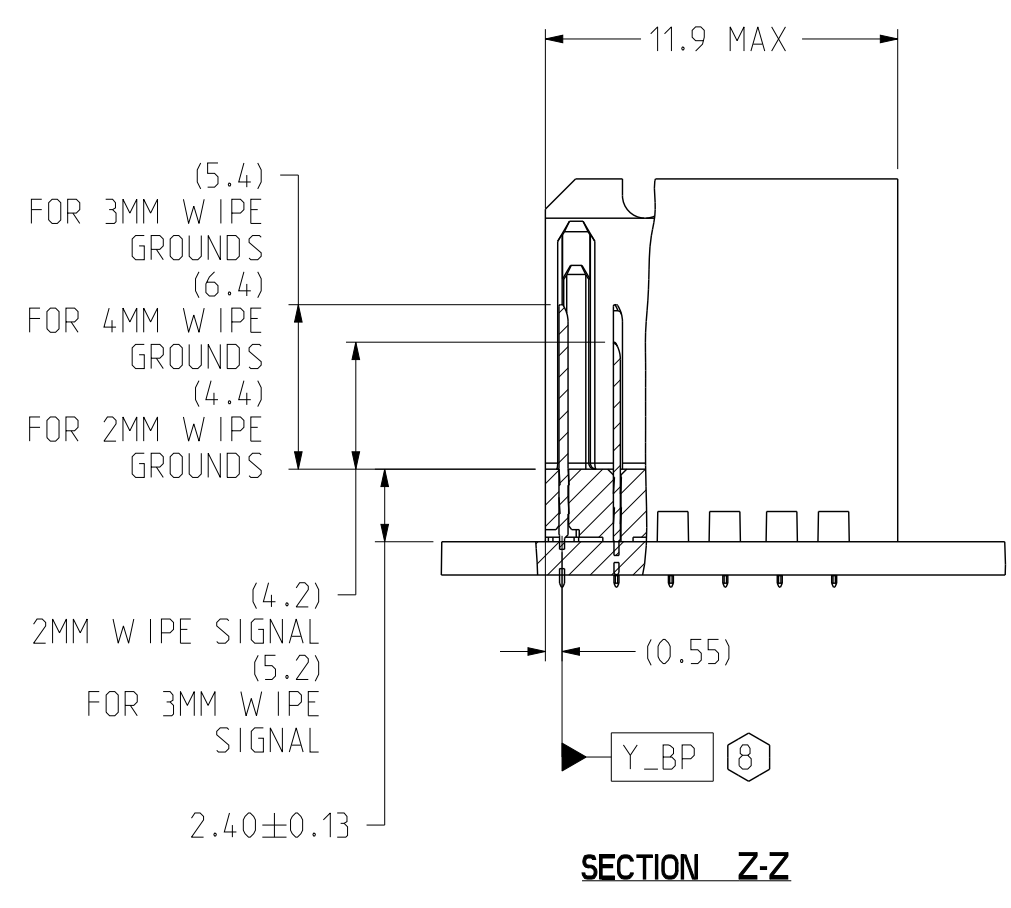

SECTION Z-Z

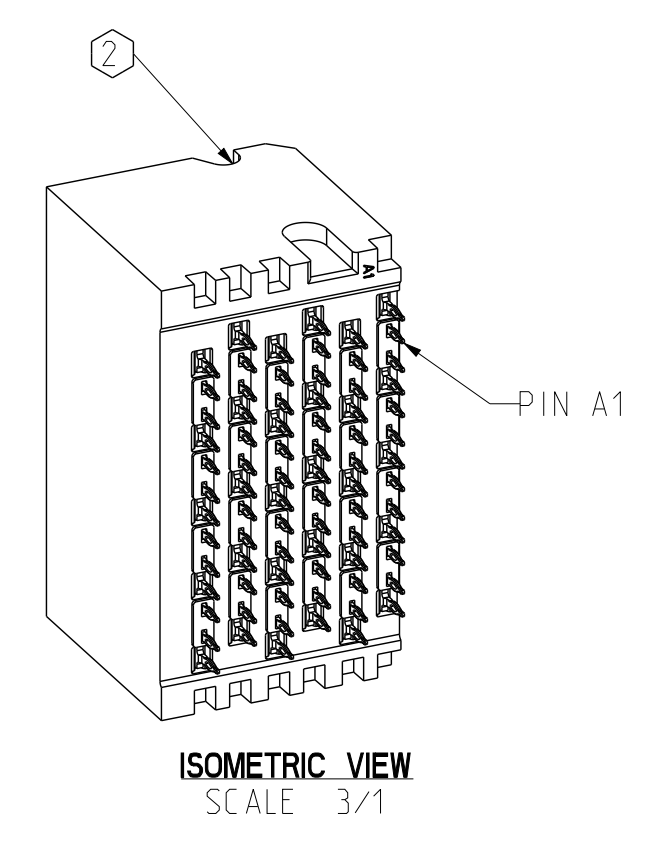
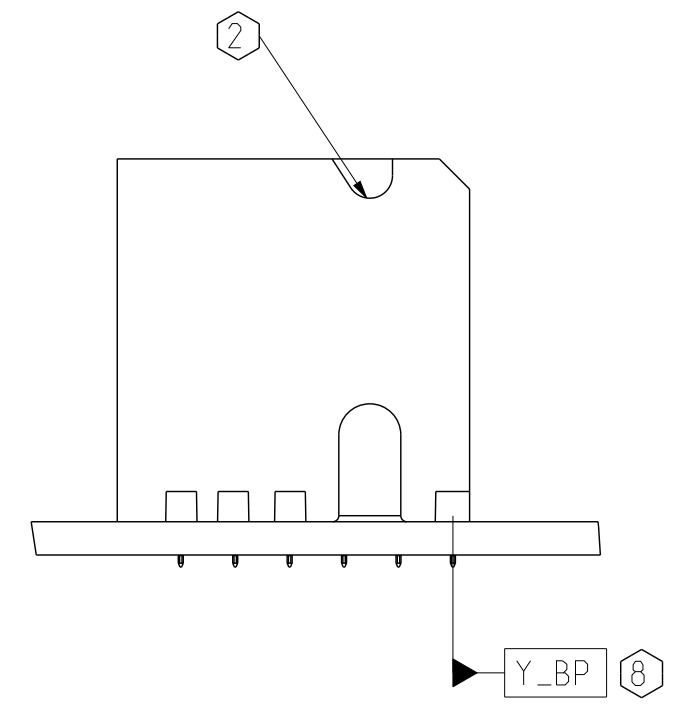
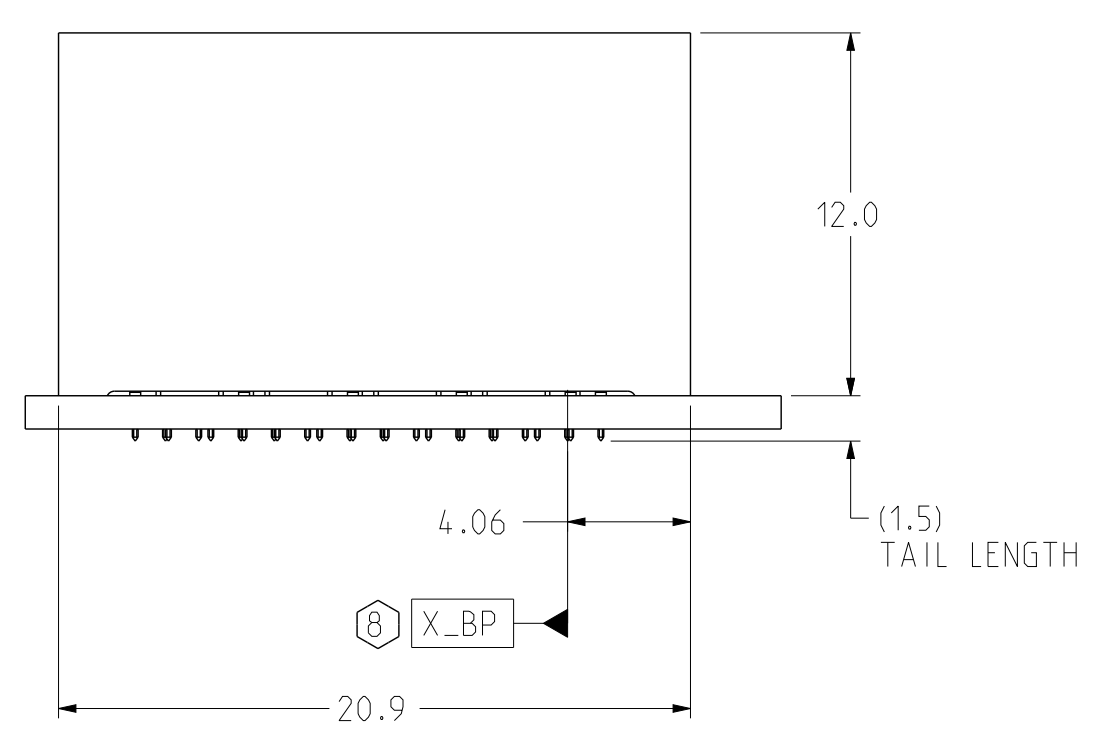

ISOMETRIC VIEW SCALE 3/1

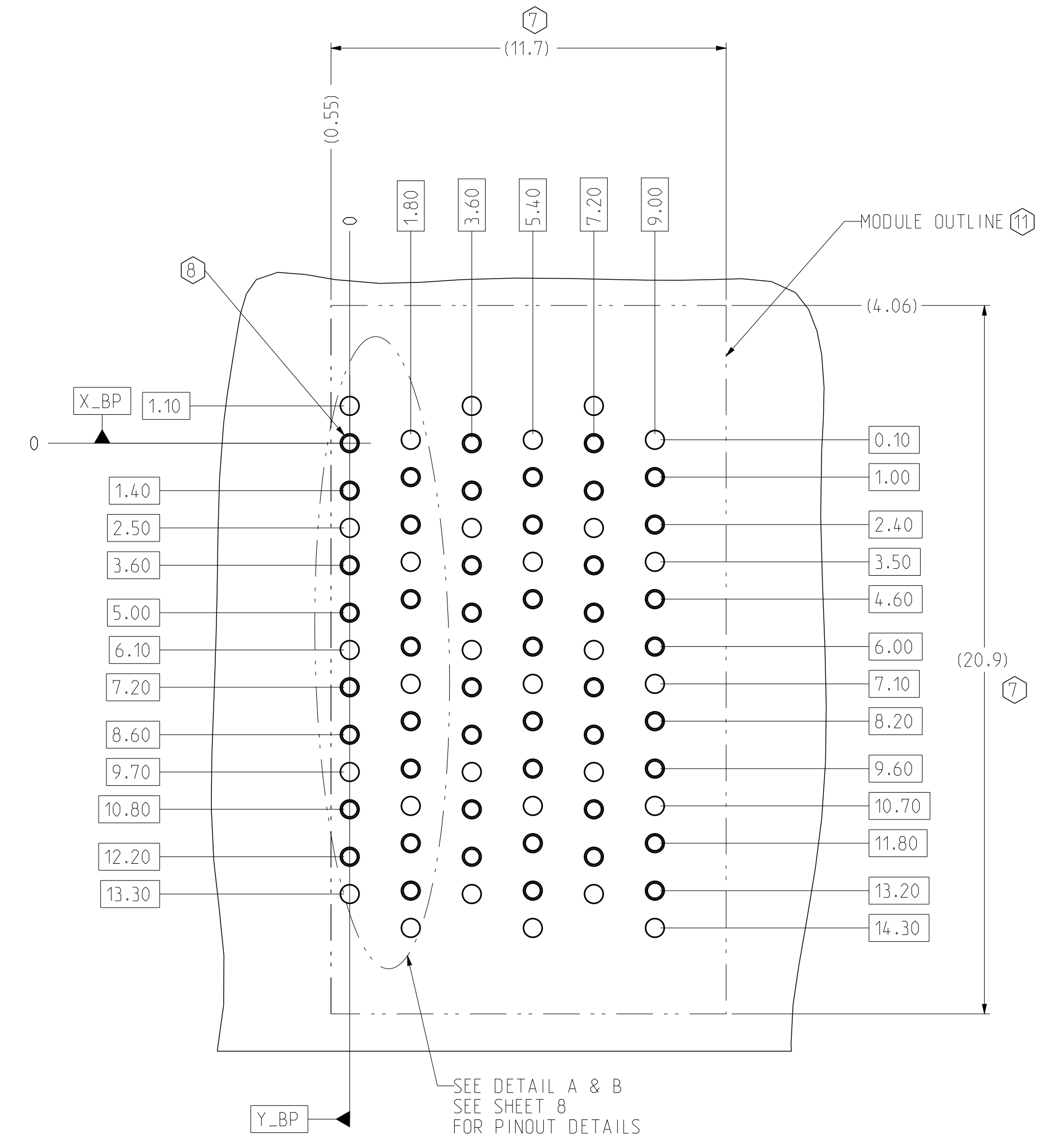

BP HOLE PATTERN COMPONENT SIDE SCALE 8/1

RIGHT WALL BACKPLANE FOOTPRINT

TOLERANCES		DESIGN 12/26/2014 M.HANRAHAN	Amphenol TCS A Division of Amphenol Corporation 200 Innovative Way, Nashua, NH 03062 603.879.3000
0.0	±0.25	DRAWN 12/26/2014 HCL-RV	
0.00	±0.13	CHK 12/26/2014 M.HANRAHAN	TITLE BACKPLANE MODULES, VERTICAL MALE HEADER X/EHD HD PLUS, 4 PAIR @ POS. THICK WALL WITH EXTRA GROUND
0.000	± -	APVD 12/26/2014 M.HANRAHAN	PART NO. SEE PN TREE SHEET 1
ANGLES	± 3°	UNLESS OTHERWISE SPECIFIED DIMENSIONS ARE IN MM. DECIMAL MARKER IS A PERIOD.	
DRAWING NO.		C-926-401C-500	REV D
ASSEMBLY		ASSEM: C926-401C-500_XG 0.0	SCALE 1/1
DRAWING		DRAWING: C926-401C-500 0.6	SHEET 6 OF 9

INTERPRET PER ASME Y14.5M
CODE IDENT 31413

CUSTOMER USE
DRAWING

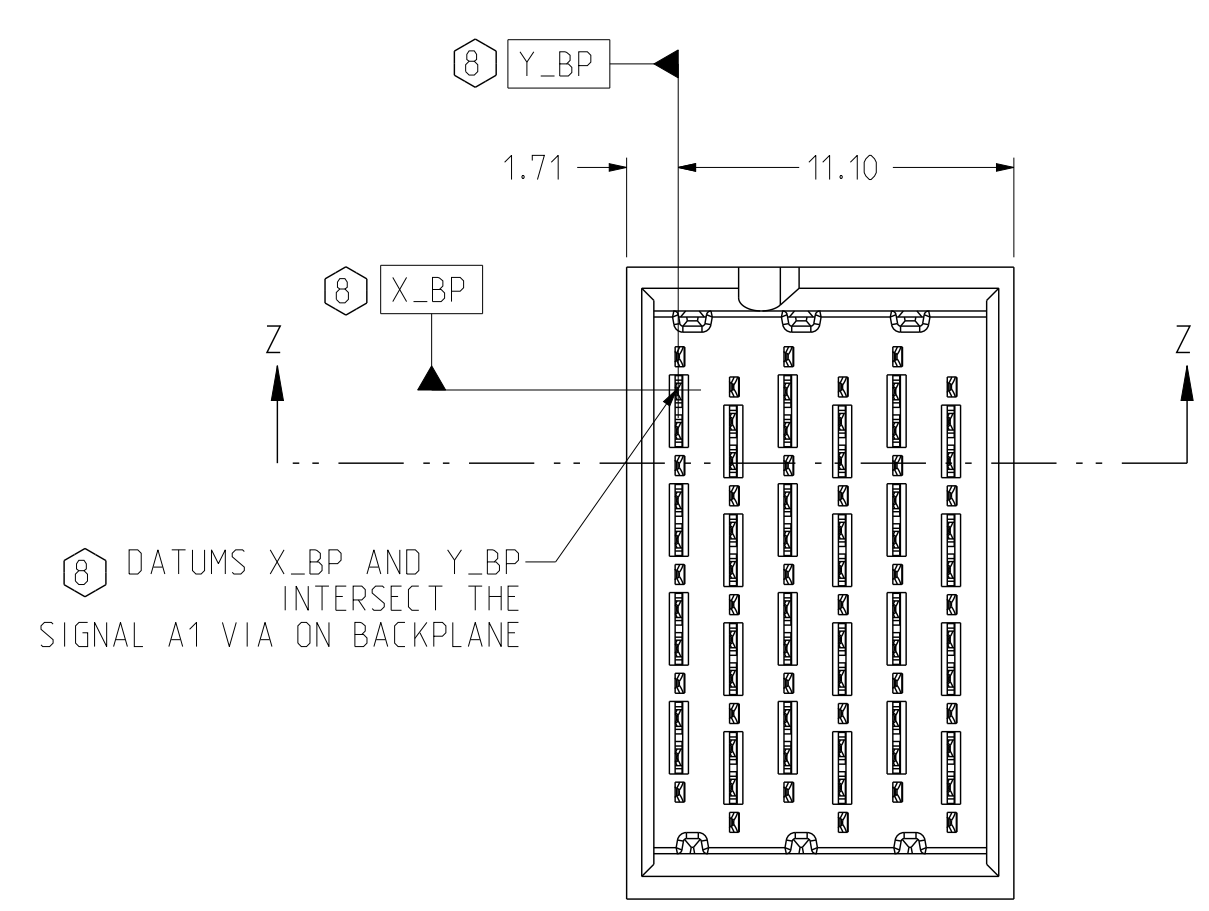

TWO WALL BACKPLANE MODULE DIMENSION

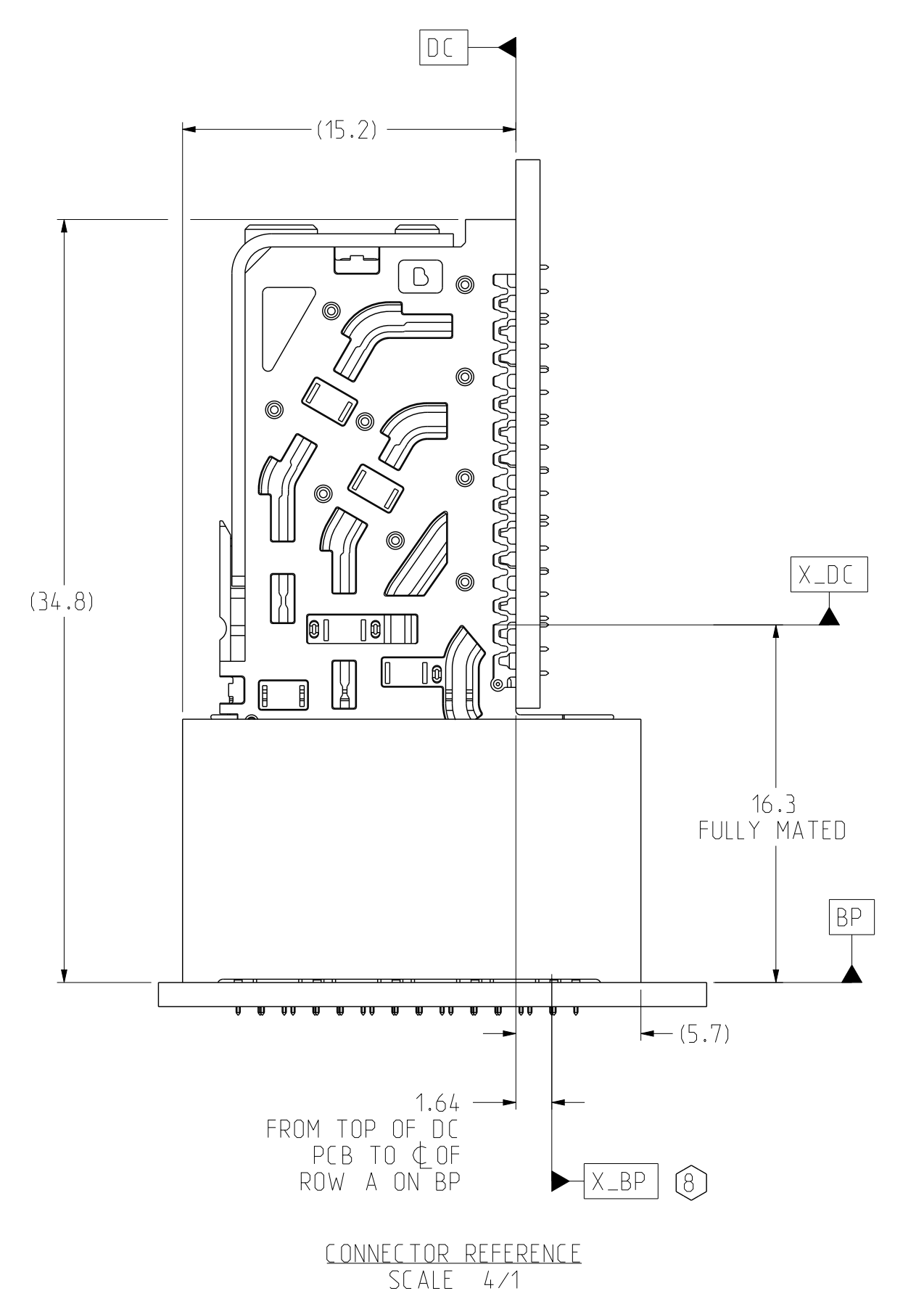

CONNECTOR REFERENCE SCALE 4/1

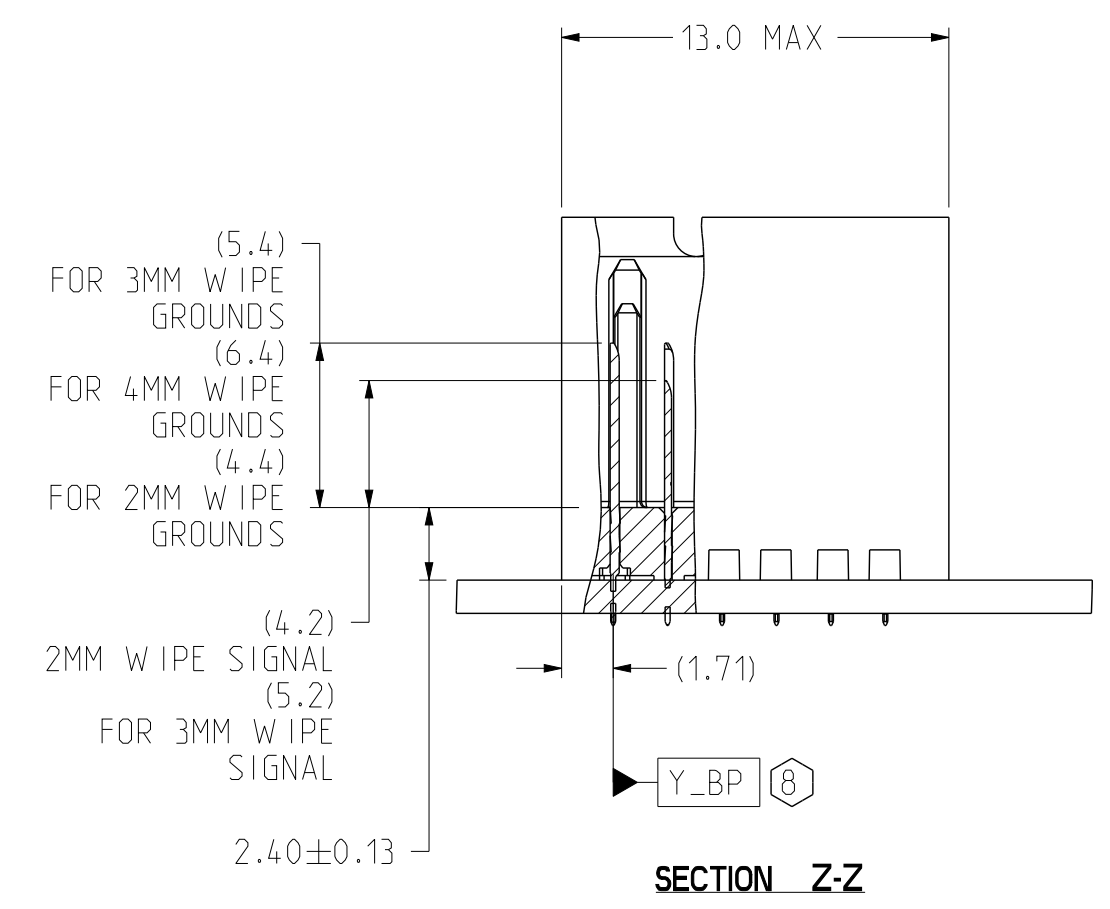

SECTION Z-Z

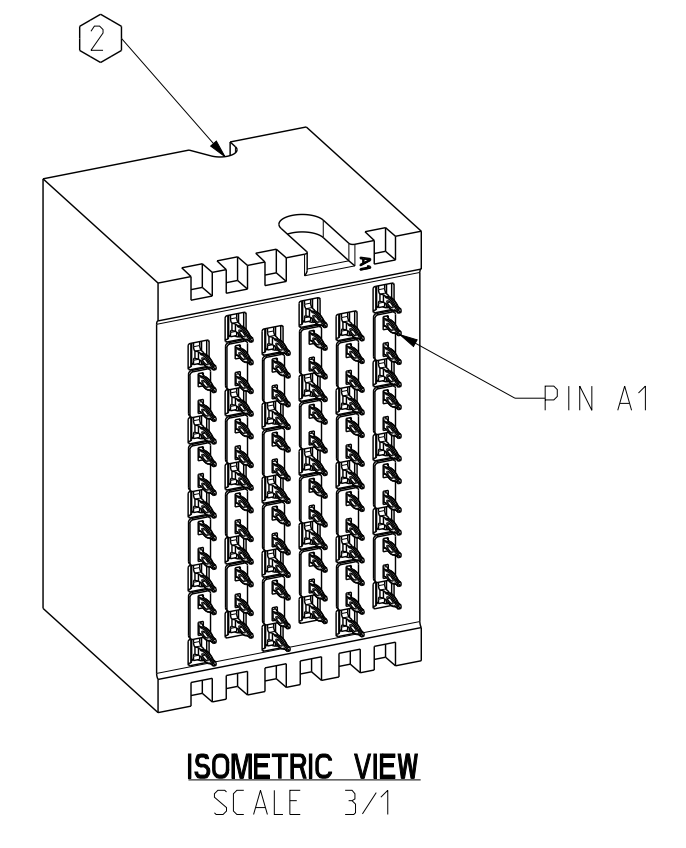
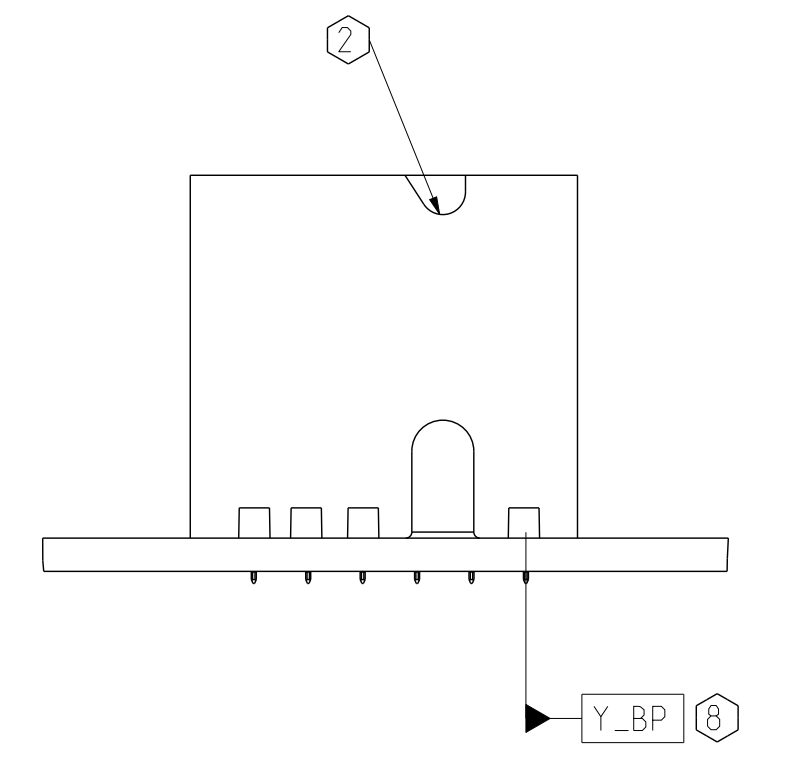
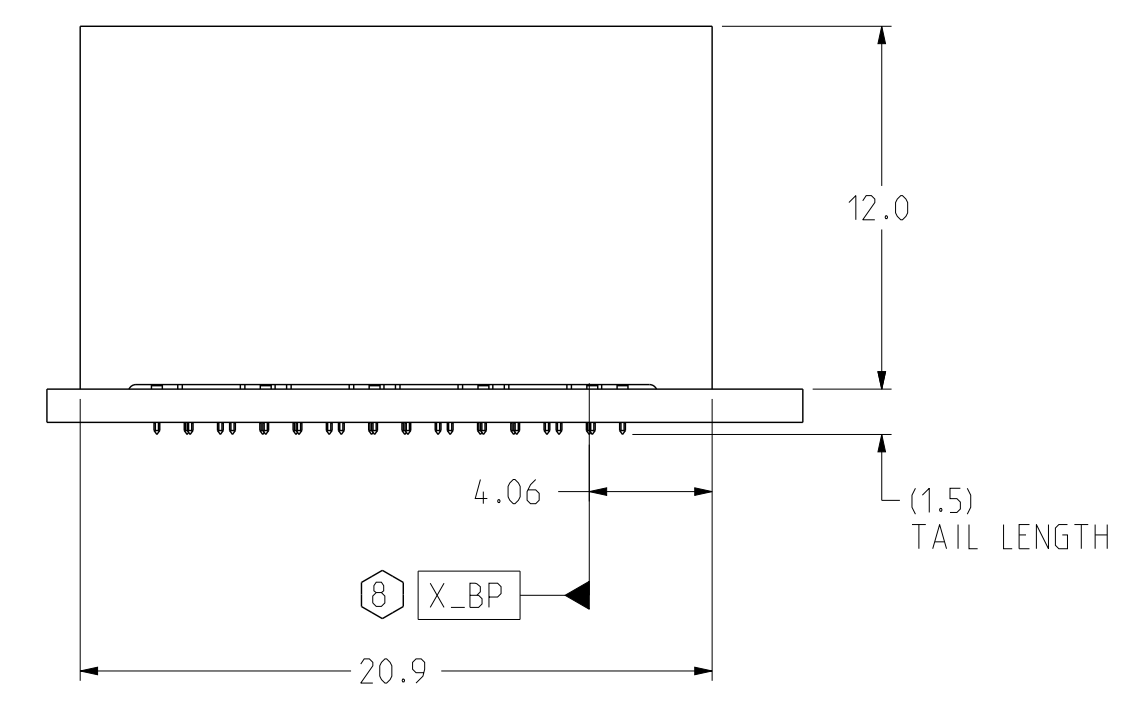

ISOMETRIC VIEW SCALE 3/1

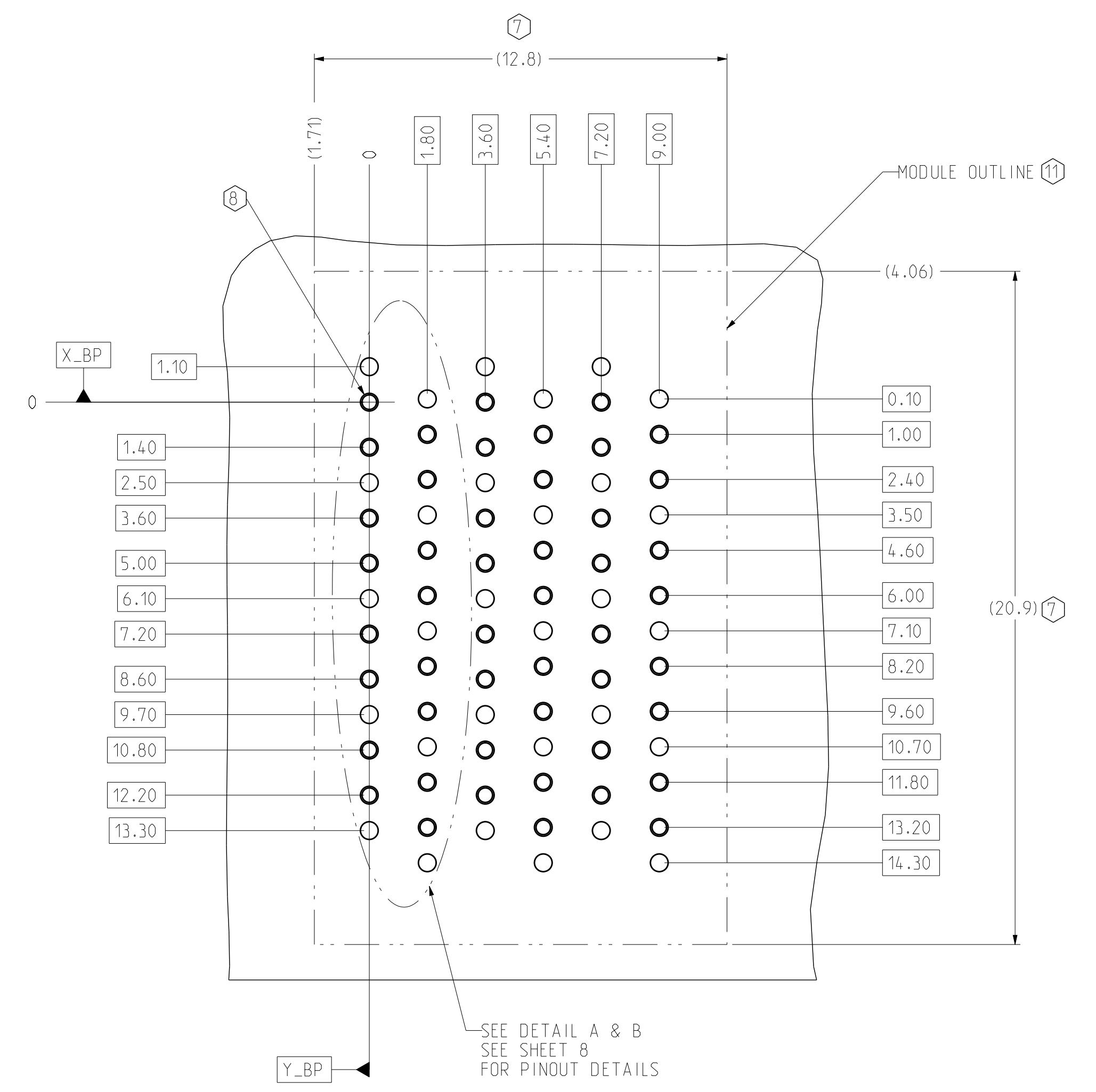

BP HOLE PATTERN COMPONENT SIDE SCALE 8/1

TWO WALL BACKPLANE FOOTPRINT

TOLERANCES		DESIGN 12/26/2014 M.HANRAHAN	Amphenol TCS A Division of Amphenol Corporation 200 Innovative Way, Nashua, NH 03062 603.879.3000
0.0	±0.25	DRAWN 12/26/2014 HCL-RV	
0.00	±0.13	CHK 12/26/2014 M.HANRAHAN	
0.000	±	APVD 12/26/2014 M.HANRAHAN	
ANGLES ± 3°		TITLE BACKPLANE MODULES, VERTICAL MALE HEADER XREF: HD PLUS, 4 PAIR & POS, THICK WALL WITH EXTRA GROUND	
UNLESS OTHERWISE SPECIFIED DIMENSIONS ARE IN MM. DECIMAL MARKER IS A PERIOD		PART NO. SEE PN TREE SHEET 1	REV N/A
DRAWING NO. C-926-401C-500		ASSEM: C926-401C-500_XG 0.0 DRAWING: C926-401C-500 0.6	
SIZE D	SCALE 1/1	SHEET 7 OF 9	

INTERPRET PER ASME Y14.5M
CODE IDENT 31413

CUSTOMER USE
DRAWING

ZONE	REV	ECN	DESCRIPTION	BY	DATE	APPROVED
			SEE SHEET 1			

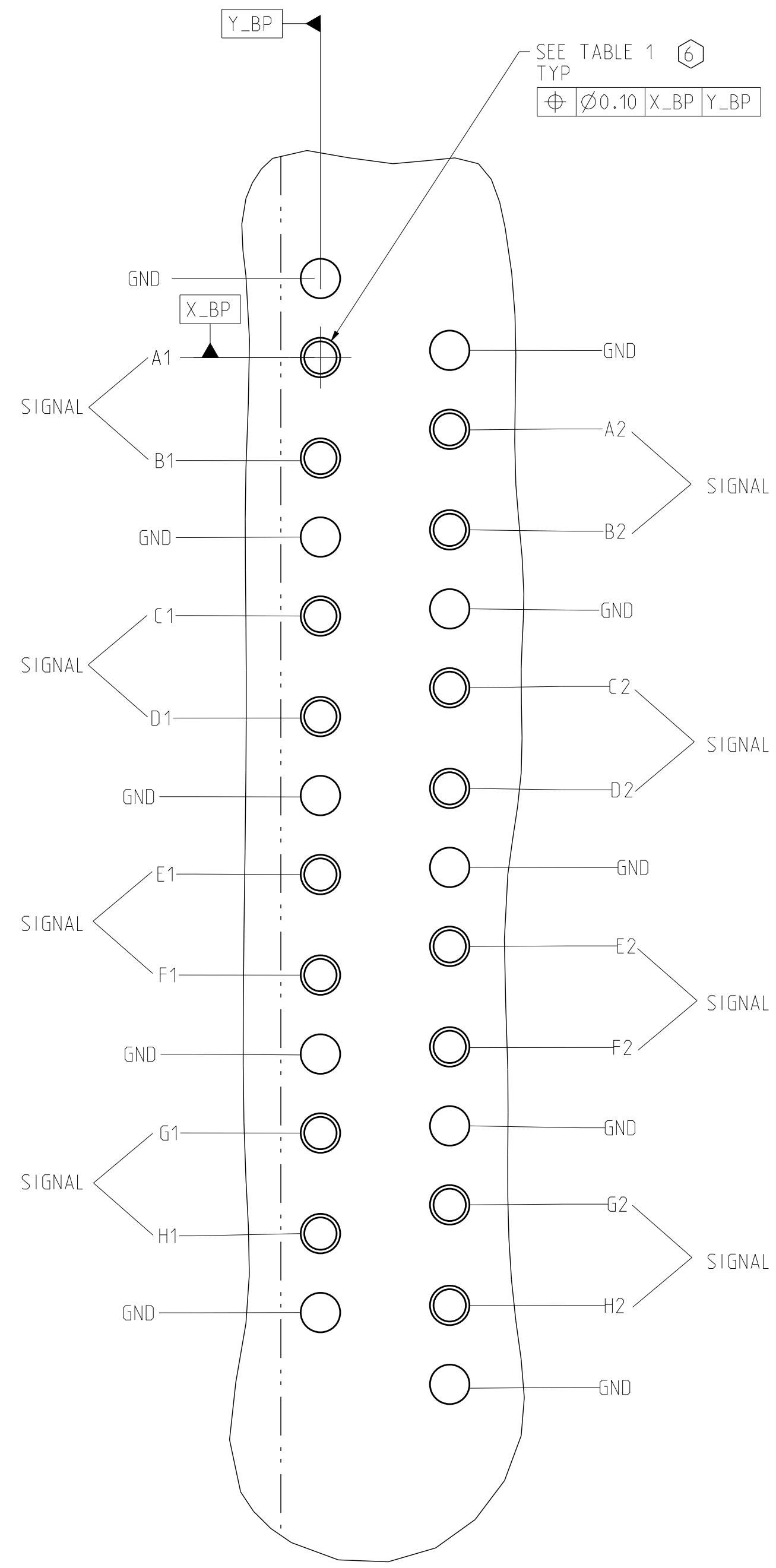

DETAIL A
HSD PINOUTS
SCALE 16/1

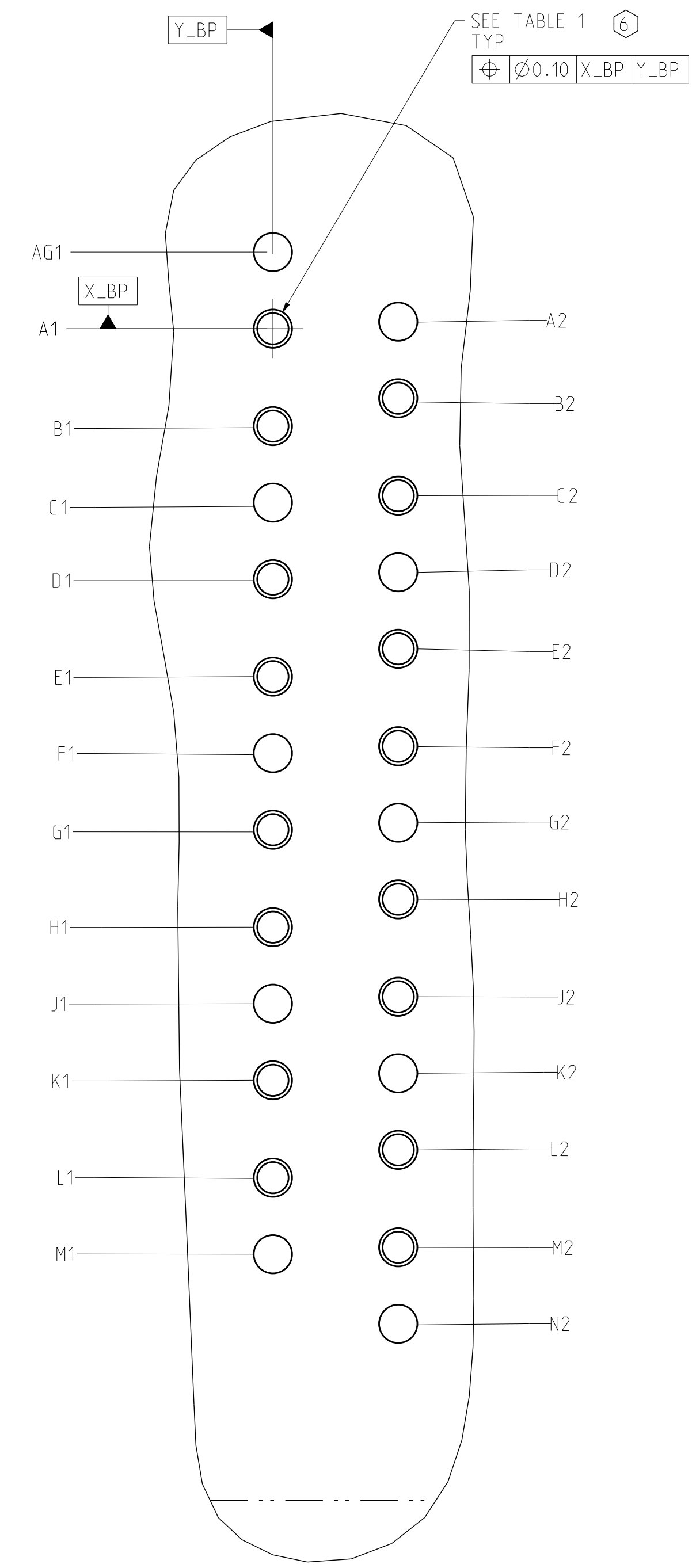

DETAIL B
LC PINOUTS
SCALE 16/1

TABLE 1

	COMPLIANT PIN DRILL \varnothing .0217"	COMPLIANT PIN DRILL \varnothing .0177"
PTH	\varnothing 0.45 \pm 0.05	\varnothing 0.36 \pm 0.05
DRILL	\varnothing 0.55 [.0217"]	\varnothing 0.45 [.0177"]
PAD	\varnothing 0.85	\varnothing 0.75

TOLERANCES		DESIGN 12/26/2014 M.HANRAHAN	Amphenol TCS A Division of Amphenol Corporation 200 Innovative Way, Nashua, NH 03082 603.879.3000
0.0	\pm 0.25	DRAWN 12/26/2014 HCL-RV	
0.00	\pm 0.13	CHK 12/26/2014 M.HANRAHAN	
0.000	\pm -	APVD 12/26/2014 M.HANRAHAN	
ANGLES	\pm 3°	TITLE BACKPLANE MODULES, VERTICAL MALE HEADER *See HD PLUS, L PAIR & POS. THICK WALL WITH EXTRA GROUND	
UNLESS OTHERWISE SPECIFIED DIMENSIONS ARE IN MM. DECIMAL MARKER IS A PERIOD.			PART NO. SEE PN TREE SHEET 1
DRAWING NO. C-926-401C-500			REV D
ASSEM: C926-401C-500_XG 0.0			0.0
DRAWING: C926-401C-500 0.6			0.6
SIZE	D	SCALE 1/1	SHEET 8 OF 9

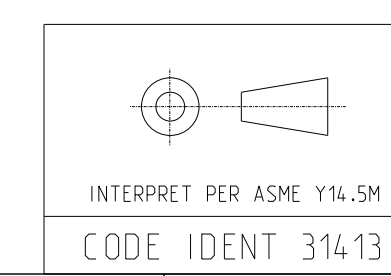

DRW NO.	C-926-401C-500	SH	9	REV	D	
ZONE	REV	ECN	DESCRIPTION	BY	DATE	APPROVED
			SEE SHEET 1			

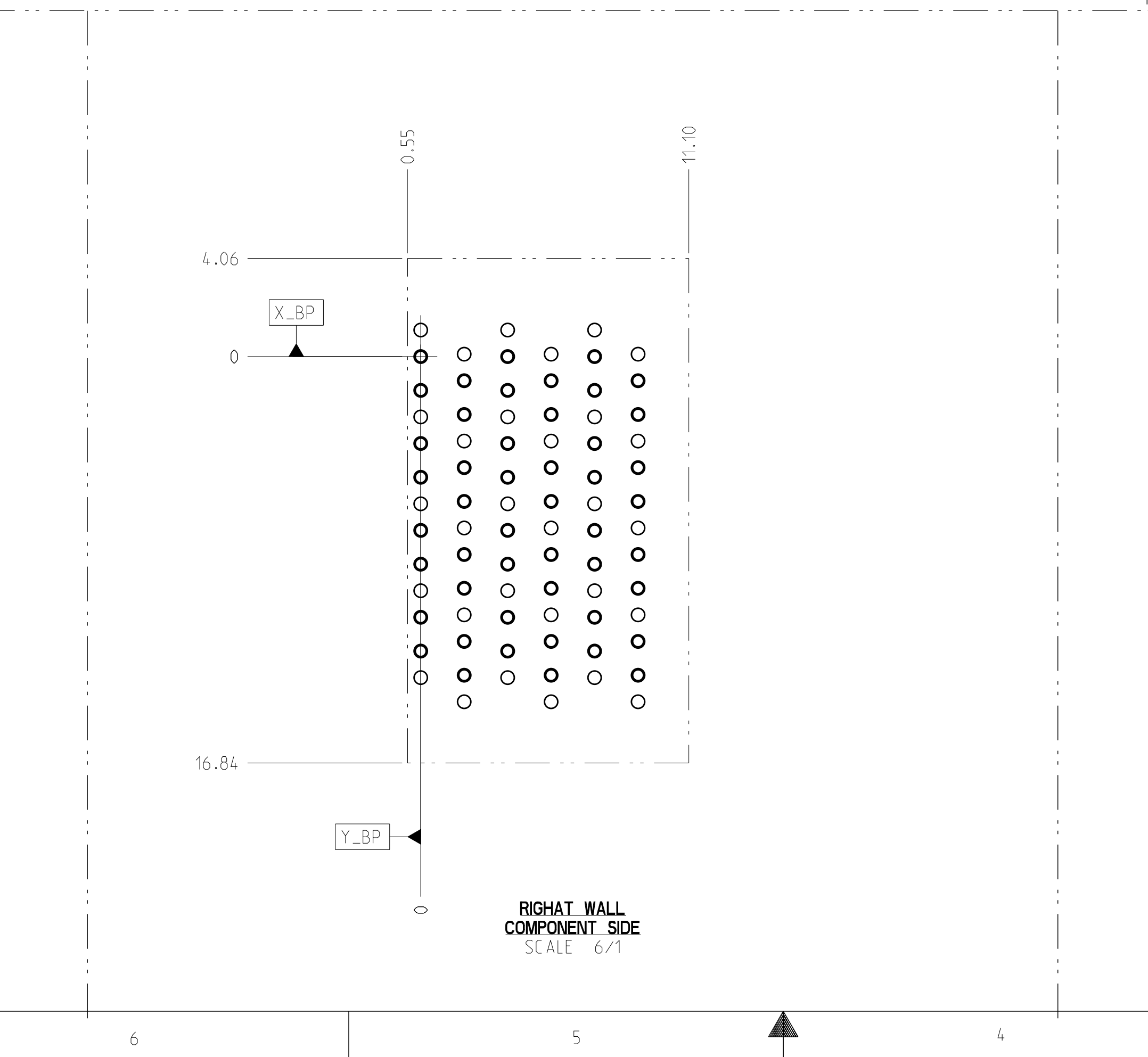
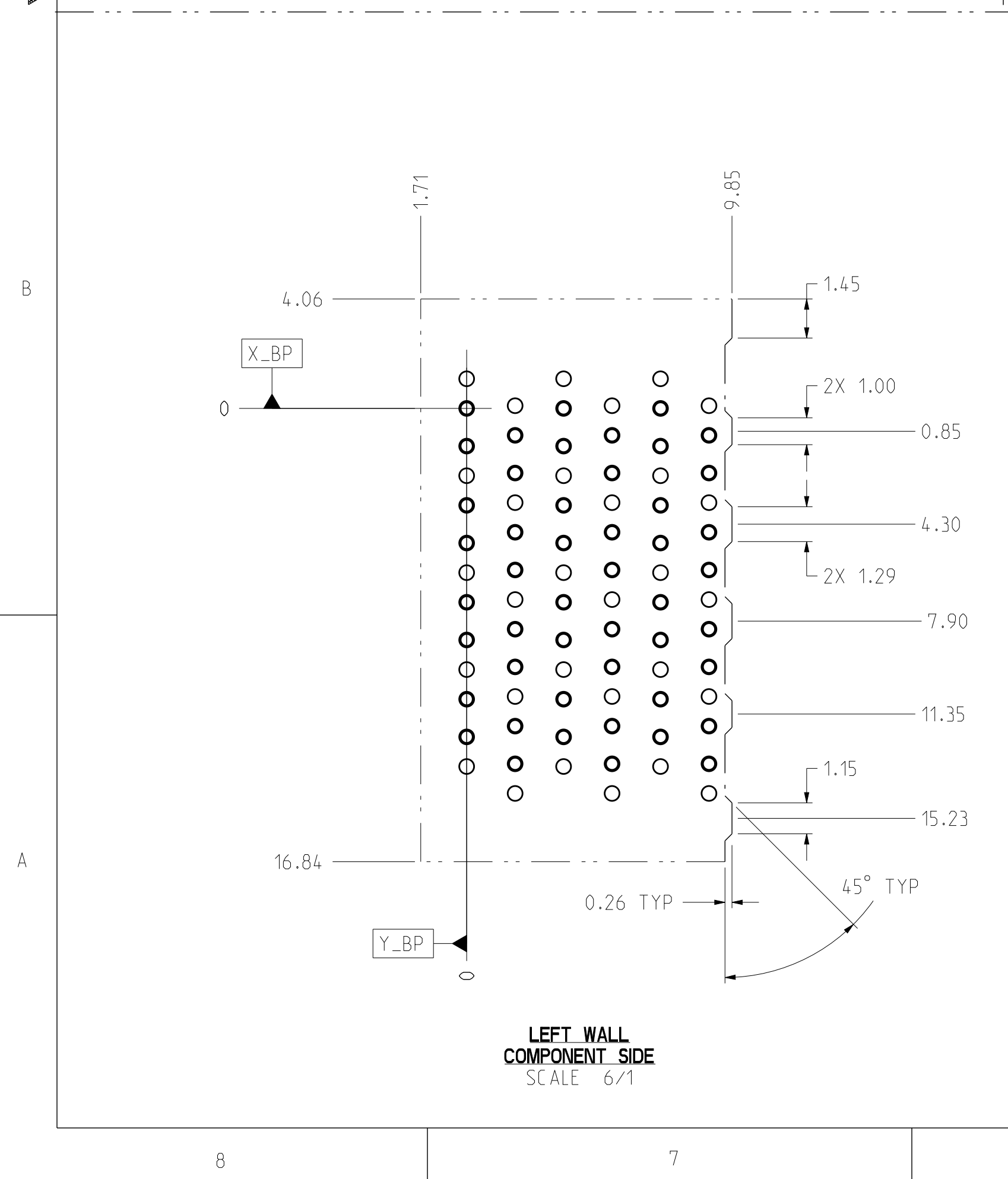
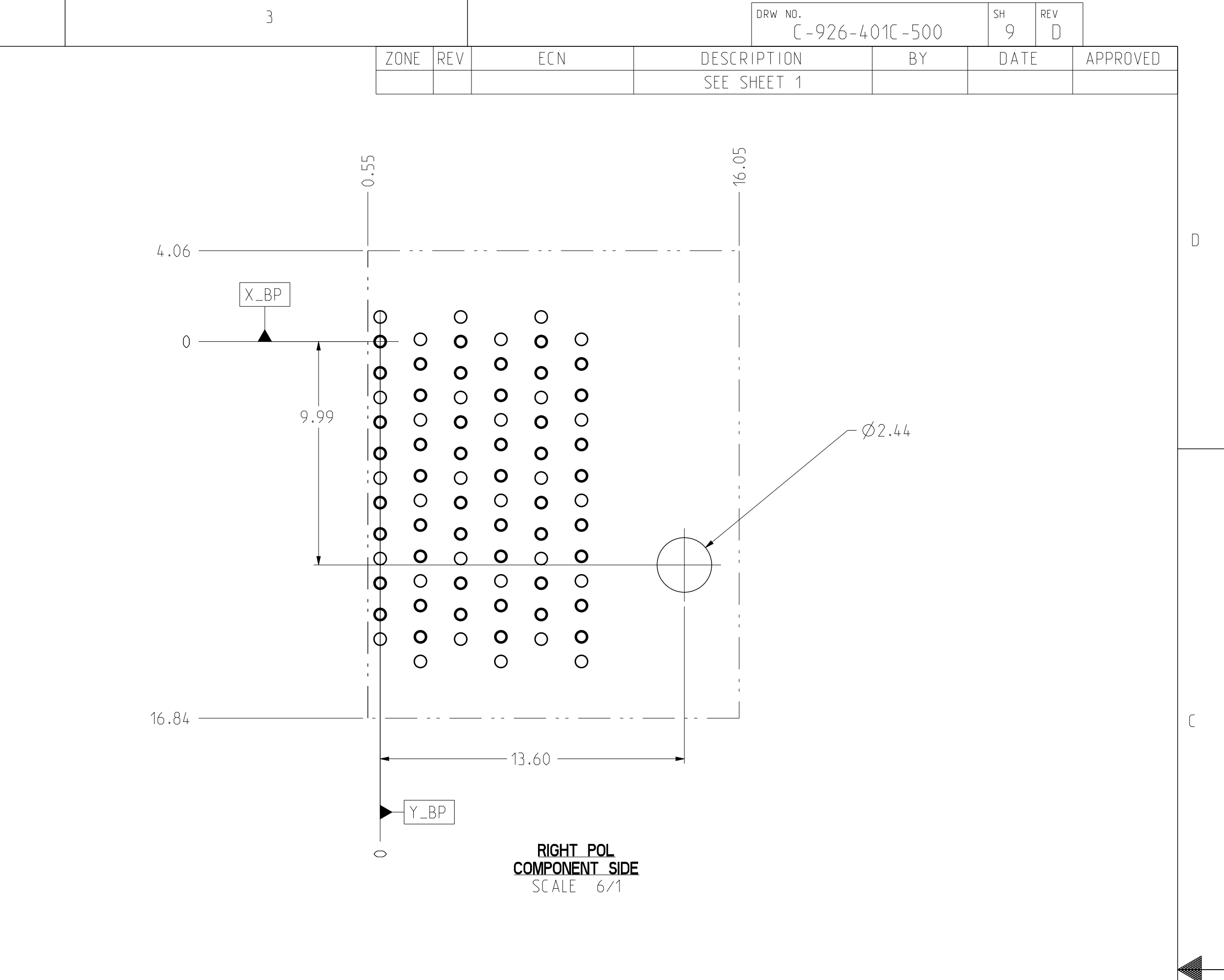
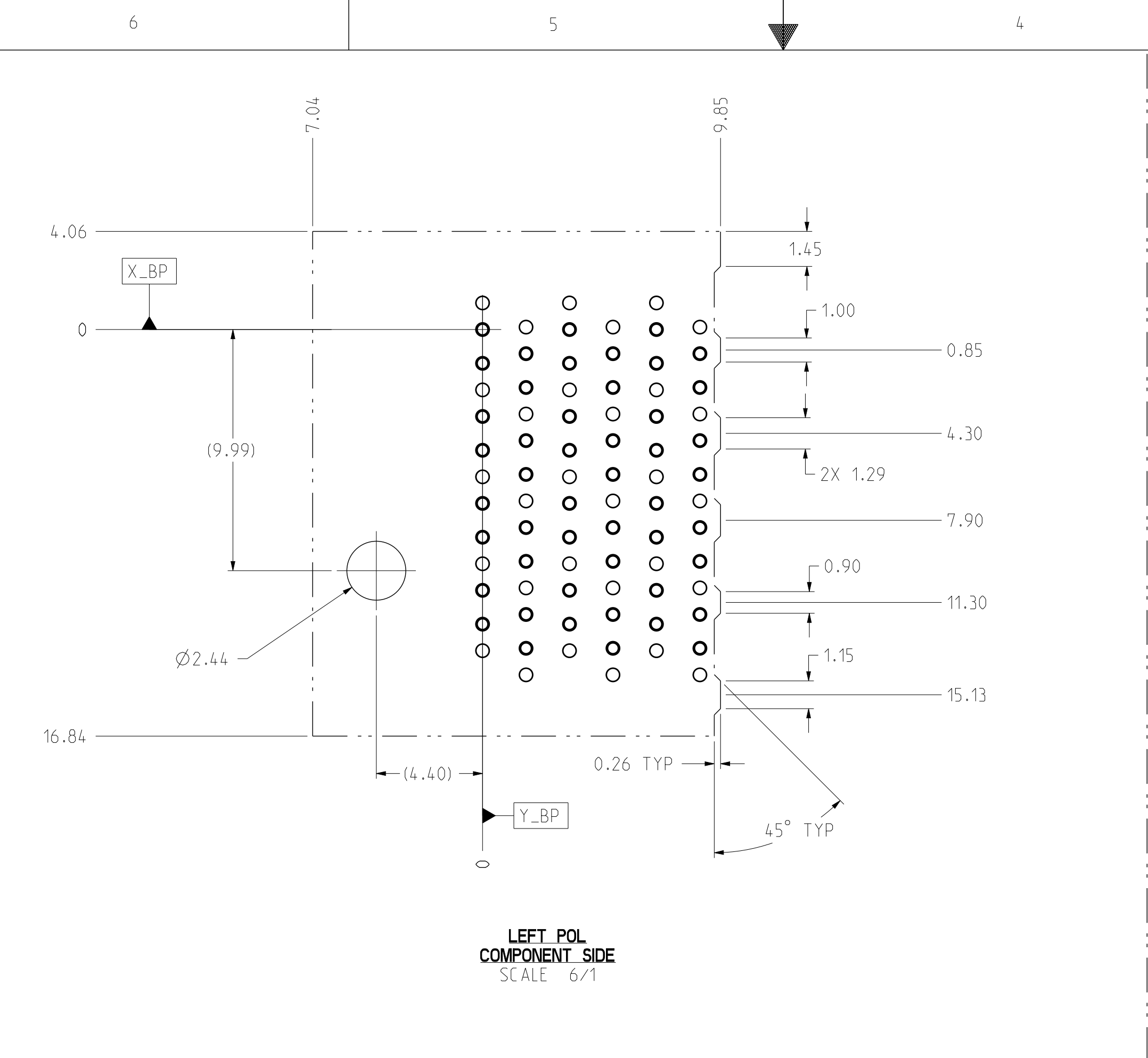
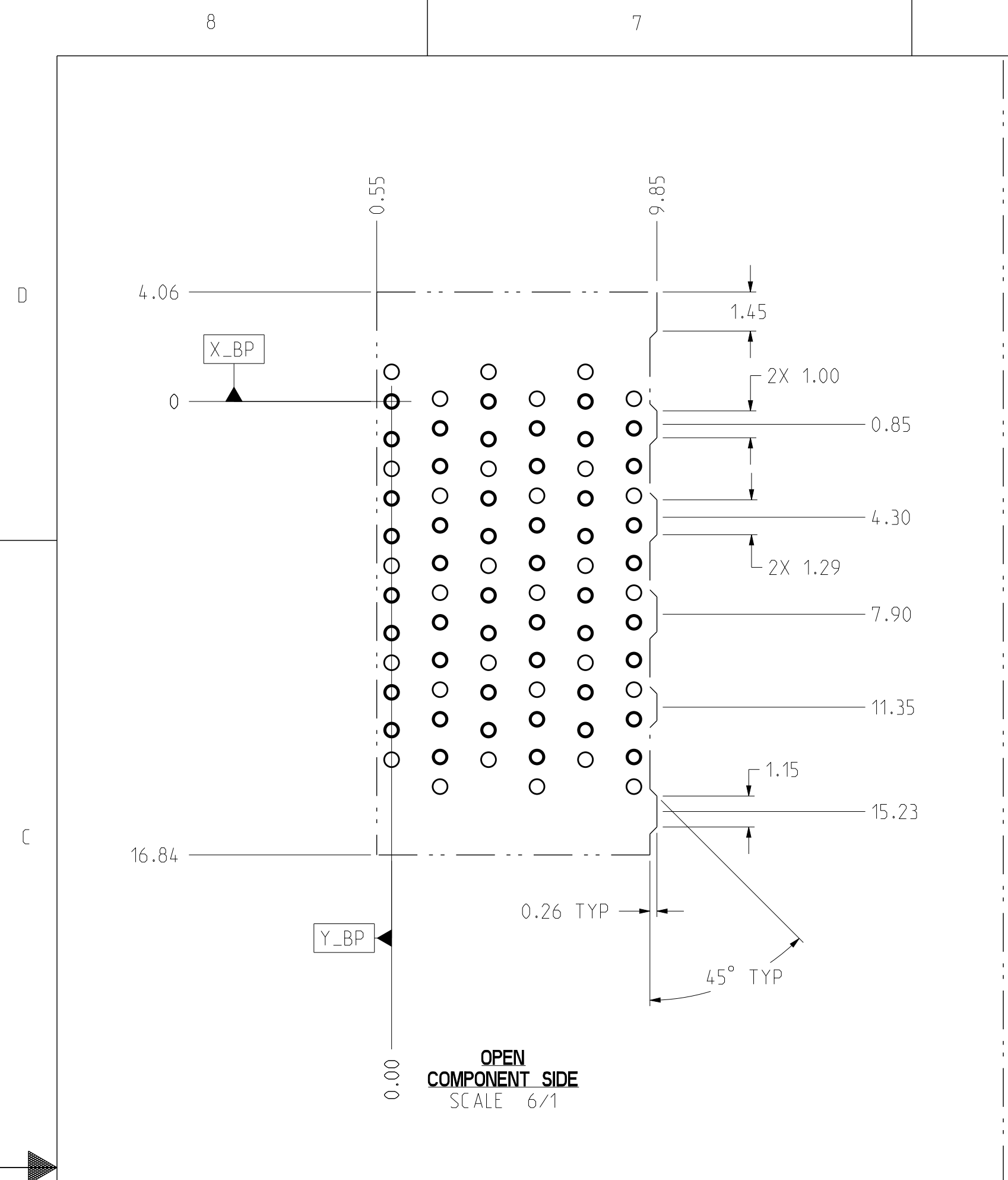

SILK SCREEN DETAILS FOR BACKPLANE MODULE OUTLINE

TOLERANCES		DESIGN 05/13/2014 M.HANRAHAN	Amphenol TCS A Division of Amphenol Corporation 200 Innovative Way, Nashua, NH 03062 603.879.3000
0.0	±0.25	DRAWN 12/26/2014 HCL-RV	
0.00	±0.13	CHK 12/26/2014 M.HANRAHAN	
0.000	± -	APVD 12/26/2014 M.HANRAHAN	
ANGLES ± 3°		TITLE BACKPLANE MODULES, VERTICAL MALE HEADER *See HD PLUS, 4 PAIR & POS. THICK WALL WITH EXTRA GROUND	
UNLESS OTHERWISE SPECIFIED DIMENSIONS ARE IN MM. DECIMAL MARKER IS A PERIOD		PART NO. SEE PN TREE SHEET 1	
DRAWING NO. C-926-401C-500		REV D	
CUSTOMER USE DRAWING		ASSEM: C926-401C-500_XG 0.0 DRAWING: C926-401C-500 0.6	
SIZE D	SCALE 1/1	SHEET 9 OF 9	

