

MATERIALS AND FINISHES

BODY ZINC ALLOY  
PLATED NICKEL

CENTER CONTACT PHOSPHOR BRONZE  
PLATED GOLD

INSULATOR POLYPROPYLENE (94 V-2)

HOUSING VALOX 420-SE0  
COLOR BLACK

SOLDER TAIL COPPER OVER STEEL WIRE  
PLATED TIN

FRONT CLIP PHOSPHOR BRONZE  
PLATED NICKEL

CHIP CAPACITOR MULTILAYER CERAMIC

BOARD LOCK CLIP PHOSPHOR BRONZE  
PLATED TIN

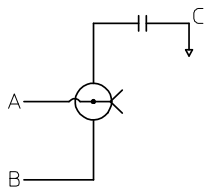
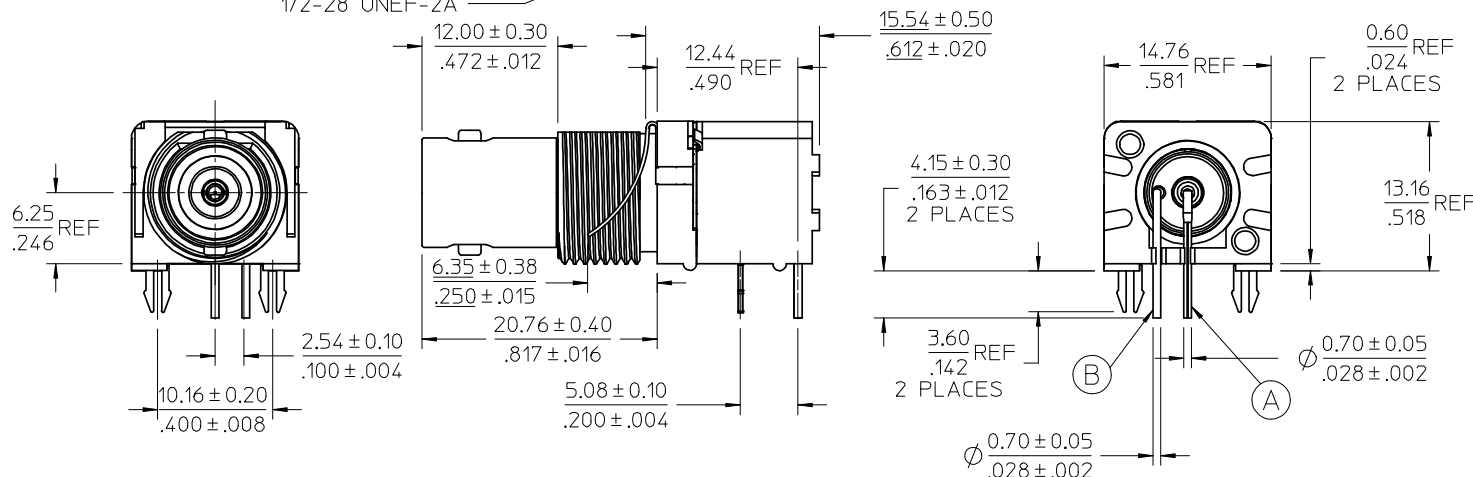
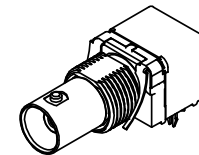
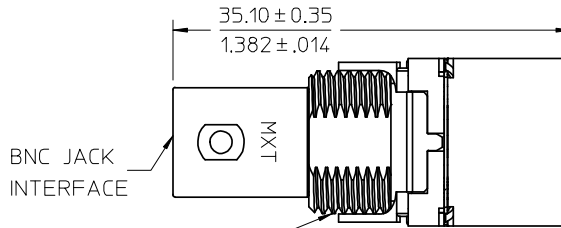

SCHEMATIC  
9400 ± 20% PF, 1.5 KV W V<sub>dc</sub>

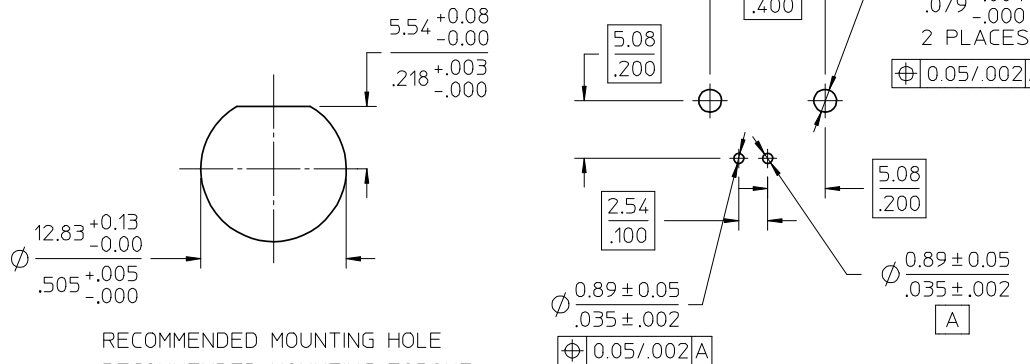

RECOMMENDED MOUNTING HOLE  
RECOMMENDED MOUNTING TORQUE:  
0.56 N-m(5.00 IN-LBS)  
PANEL THICKNESS: 5.5(.217) MAX

RECOMMENDED PCB HOLE

PART # 73100-0134

ES-73599-0000	INTERFACE
PS-73598-0010	ELECTRO/MECH PERFORM.
SPECIFICATION	DESCRIPTION

CHG: CONVERT TO SOLID DESIGNER EC NO: URF2008-0413 DRWN: WIENER 2008/02/08 CHKD: SHAH 2008/02/08 APPR: WIENER 2008/02/11 REV: B1	QUALITY SYMBOLS ▽=0 ▽=0	GENERAL TOLERANCES (UNLESS SPECIFIED) <table border="1"> <tr> <th></th> <th>mm</th> <th>INCH</th> </tr> <tr> <td>4 PLACES</td> <td>± .005</td> <td>± .0004</td> </tr> <tr> <td>3 PLACES</td> <td>± .005</td> <td>± .0004</td> </tr> <tr> <td>2 PLACES</td> <td>± .005</td> <td>± .0004</td> </tr> <tr> <td>1 PLACE</td> <td>± .005</td> <td>± .0004</td> </tr> </table> ANGULAR ± 2 °		mm	INCH	4 PLACES	± .005	± .0004	3 PLACES	± .005	± .0004	2 PLACES	± .005	± .0004	1 PLACE	± .005	± .0004	DIMENSION STYLE MM/IN	SCALE DESIGN UNITS METRIC	THIRD ANGLE PROJECTION
		mm	INCH																	
4 PLACES	± .005	± .0004																		
3 PLACES	± .005	± .0004																		
2 PLACES	± .005	± .0004																		
1 PLACE	± .005	± .0004																		
DRAWN BY THOMPSON DATE 1994/02/16 CHECKED BY IRIS WANG DATE 1994/02/16 APPROVED BY R FIELDS DATE 1994/02/16	TITLE BNC JACK, R/A RECEPTACLE 50 OHMS FILTER BNC-J/PCB/RA/BK		MOLEX MOLEX INCORPORATED		SHEET NO. 1 OF 1															
DRAFT WHERE APPLICABLE MUST REMAIN WITHIN DIMENSIONS		MATERIAL NO. 731000134	DOCUMENT NO. SD-73100-0134	THIS DRAWING CONTAINS INFORMATION THAT IS PROPRIETARY TO MOLEX INCORPORATED AND SHOULD NOT BE USED WITHOUT WRITTEN PERMISSION																