

AC Controller Modules

$I_{RMS} = 112 \text{ A}$
 $V_{RRM} = 800-1400 \text{ V}$

Preliminary Data

V_{RSM} V_{DSM} V	V_{RRM} V_{DRM} V	Type	
800	800	MMO 110-08io7	MLO 110-08io7
1200	1200	MMO 110-12io7	MLO 110-12io7
1400	1400	MMO 110-14io7	MLO 110-14io7

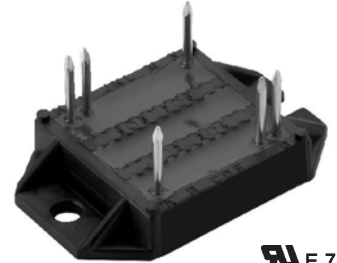
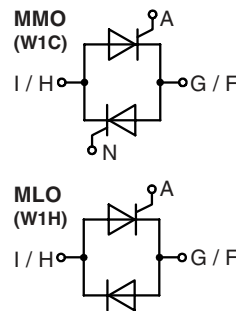

Symbol	Conditions	Maximum Ratings	
I_{RMS}	$T_C = 85^\circ\text{C}$, 50 - 400 Hz, module	112	A
I_{TRMS}		81	A
I_{TAVM}	$T_C = 85^\circ\text{C}$; (180° sine)	51	A
I_{TSM}	$T_{VJ} = 45^\circ\text{C}$ $V_R = 0$	t = 10 ms (50 Hz), sine t = 8.3 ms (60 Hz), sine	1000 A 1070 A
	$T_{VJ} = 125^\circ\text{C}$ $V_R = 0$	t = 10 ms (50 Hz), sine t = 8.3 ms (60 Hz), sine	870 A 930 A
I^2t	$T_{VJ} = 45^\circ\text{C}$ $V_R = 0$	t = 10 ms (50 Hz), sine t = 8.3 ms (60 Hz), sine	5000 A ² s 4810 A ² s
	$T_{VJ} = 125^\circ\text{C}$ $V_R = 0$	t = 10 ms (50 Hz), sine t = 8.3 ms (60 Hz), sine	3780 A ² s 3630 A ² s
$(di/dt)_{cr}$	$T_{VJ} = 125^\circ\text{C}$ f = 50 Hz, $t_p = 200 \mu\text{s}$ $V_D = \frac{2}{3} V_{DRM}$ $I_G = 0.45 \text{ A}$ $di_G/dt = 0.45 \text{ A}/\mu\text{s}$	repetitive, $I_T = 50 \text{ A}$ non repetitive, $I_T = I_{TAVM}$	100 A/ μs 500 A/ μs
$(dv/dt)_{cr}$	$T_{VJ} = 125^\circ\text{C}$; $V_{DR} = \frac{2}{3} V_{DRM}$ $R_{GK} = \infty$; method 1 (linear voltage rise)		1000 V/ μs
P_{GM}	$T_{VJ} = 125^\circ\text{C}$	$t_p = 30 \mu\text{s}$ $t_p = 300 \mu\text{s}$	10 W 5 W
	$I_T = I_{TAVM}$		
P_{GAVM}			0.5 W
V_{RGM}			10 V
T_{VJ}			-40...+150 °C
T_{VJM}			150 °C
T_{stg}			-40...+125 °C
V_{ISOL}	50/60 Hz, RMS	t = 1 min	2500 V~
	$I_{ISOL} \leq 1 \text{ mA}$	t = 1 s	3000 V~
M_d	Mounting torque (M4)		1.5...2.0/14...18 Nm/lb.in.
Weight	typ.		18 g

Features

- Thyristor controller for AC (circuit W1C acc. to IEC) for mains frequency
- Isolation voltage 3000 V~
- Planar glass passivated chips
- Low forward voltage drop
- Lead suitable for PC board solering

Applications

- Switching and control of single and three phase AC circuits
- Light and temperature control
- Softstart AC motor controller
- Solid state switches

Advantages

- Easy to mount with two screws
- Space and weight savings
- Improved temperature and power cycling
- High power density
- Small and light weight

Data according to IEC 60747 and to a single thyristor/diode unless otherwise stated.

IXYS reserve the right to change limits, conditions and dimensions.

© 2002 IXYS All rights reserved

Symbol	Conditions	Characteristic Values	
I_D, I_R	$T_{VJ} = 125^\circ\text{C}; V_R = V_{RRM}; V_D = V_{DRM}$	\leq	5 mA
V_T	$I_T = 150 \text{ A}; T_{VJ} = 25^\circ\text{C}$	\leq	1.57 V
V_{T0}	For power-loss calculations only		0.85 V
r_T			5.6 m Ω
V_{GT}	$V_D = 6 \text{ V}$	$T_{VJ} = 25^\circ\text{C}$ $T_{VJ} = -40^\circ\text{C}$	\leq 1.5 V \leq 1.9 V
I_{GT}	$V_D = 6 \text{ V}$	$T_{VJ} = 25^\circ\text{C}$ $T_{VJ} = -40^\circ\text{C}$	\leq 100 mA \leq 200 mA
V_{GD}	$T_{VJ} = 125^\circ\text{C}; V_D = \frac{2}{3} V_{DRM}$	\leq	0.2 V
I_{GD}		\leq	1 mA
I_L	$T_{VJ} = 25^\circ\text{C}; t_p = 10 \mu\text{s}$ $I_G = 0.45 \text{ A}; di_G/dt = 0.45 \text{ A}/\mu\text{s}$	\leq	200 mA
I_H	$T_{VJ} = 25^\circ\text{C}; V_D = 6 \text{ V}; R_{GK} = \infty$	\leq	100 mA
t_{gd}	$T_{VJ} = 25^\circ\text{C}; V_D = \frac{1}{2} V_{DRM}$ $I_G = 0.45 \text{ A}; di_G/dt = 0.45 \text{ A}/\mu\text{s}$	\leq	2 μs
R_{thJC}	per thyristor; DC		0.8 K/W
	per module		0.4 K/W
R_{thCH}	per thyristor; sine 180° el	typ.	0.12 K/W
	per module	typ.	0.06 K/W
d_s	Creeping distance on surface		11.2 mm
d_A	Creepage distance in air		17.0 mm
a	Max. allowable acceleration		50 m/s ²

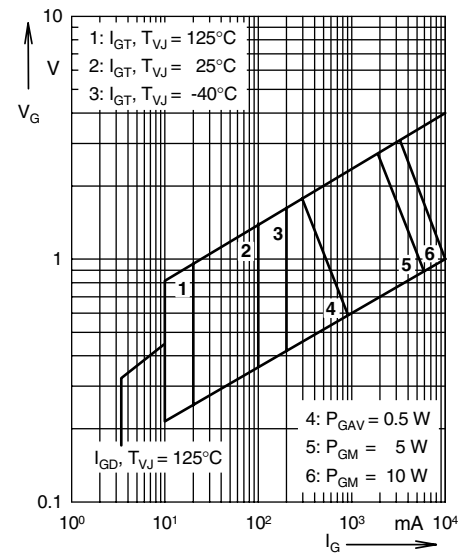
Dimensions in mm (1 mm = 0.0394")

Fig. 1 Gate trigger characteristics

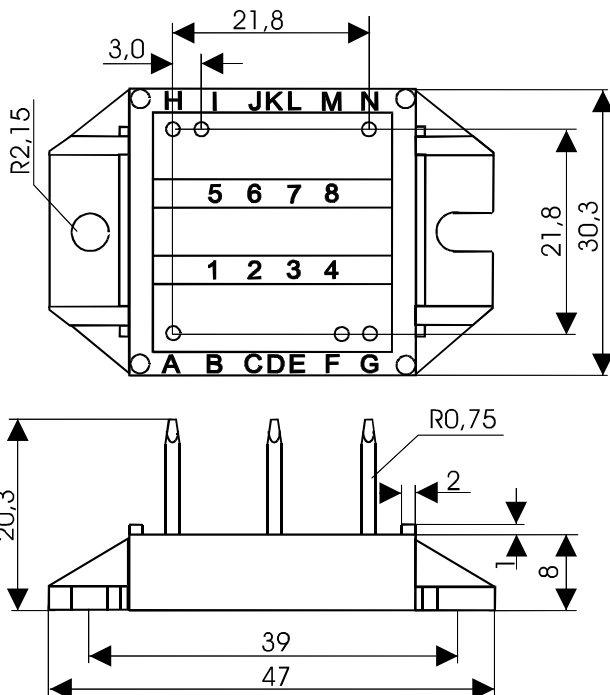
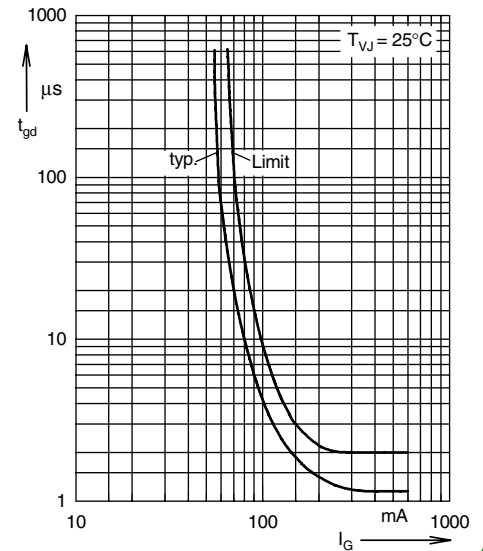

Fig. 2 Gate trigger delay time