

ITEM	DESCRIPTION	QTY	SHEETS
1	PANEL ASSEMBLY	1	2,3,5 & 6
2	COVER ASSEMBLY	1	4,5 & 6

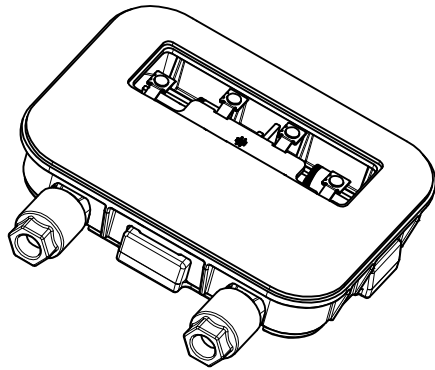

TAPE VERSION

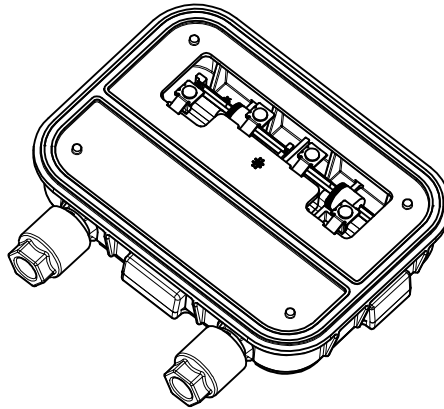
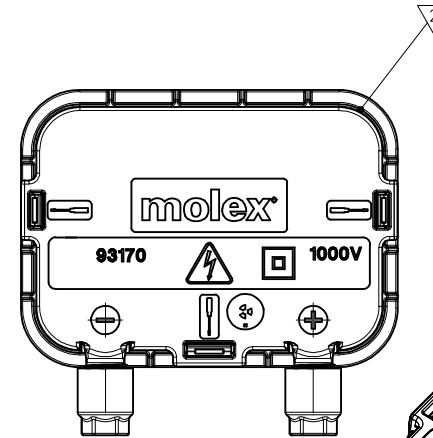
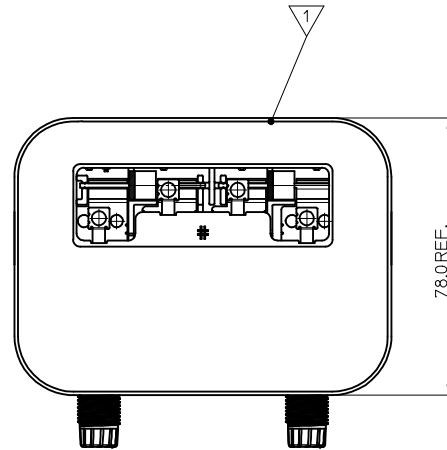

SILICONE VERSION

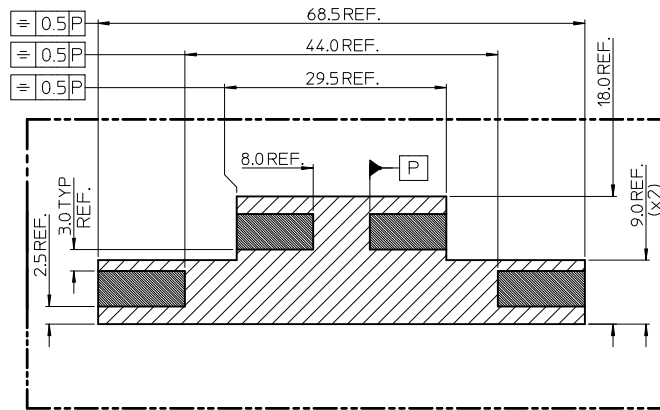

SUGGESTION FOR LAMINATE CUT-OUT
& RIBBON POSITIONS
(CUSTOMER CAN DECIDE BASED ON CAPABILITY)

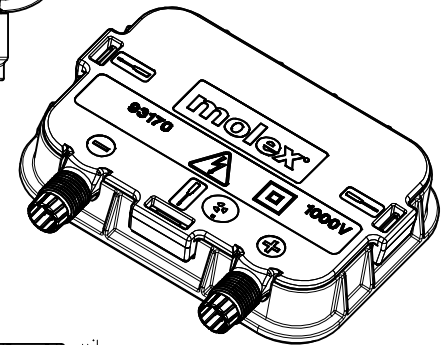
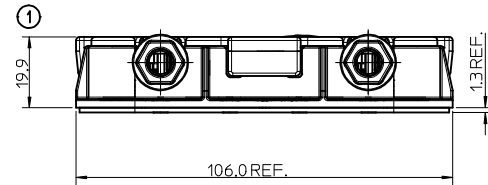

NOTES:

1. HOUSING MATERIAL: PPO, COLOUR BLACK
2. TERMINAL MATERIALS: COPPER ALLOY
3. TERMINAL PLATING: Ag AND Ni
4. IP RATING: 65
5. WITHSTAND VOLTAGE: 1000V
6. CURRENT RATING: 9A
7. TEMPERATURE RANGE: -40°C TO 85°C
8. FOR CURRENT & VOLTAGE RATINGS SEE PRODUCT SPECIFICATION: PS-93170-001
9. SEE SHEET 6 FOR PART NUMBER DETAILS

INSPECTION NUMBERS RESERVED FOR SHEET 1: 1-50
LAST INSPECTION NUMBER USED: 1

UPDATED EC NO: E2009-0584 DRAWN: SMCREEVY 2009/09/01 CHKD: SMCREEVY 2009/09/02 APPR: EFOLAN 2009/09/02	DESCRIPTION B	QUALITY SYMBOLS ▽=0 ▽=0		GENERAL TOLERANCES (UNLESS SPECIFIED)		DIMENSION STYLE MM ONLY		SCALE 1:1	DESIGN UNITS METRIC	THIRD ANGLE PROJECTION	
		4 PLACES ± --- ± --- 3 PLACES ± --- ± --- 2 PLACES ± 0.10 ± --- 1 PLACE ± 0.2 ± ---	mm INCH ± --- ± --- ± 0.10 ± --- ± 0.2 ± ---	DRAWN BY MSHANAHAN	DATE 2008/7/11	TITLE JUNCTION BOX FOR P.V. SOLAR PANEL		MOLEX INCORPORATED		MATERIAL NO. EFOLAN	DATE 2008/7/11
		DRAFT WHERE APPLICABLE MUST REMAIN WITHIN DIMENSIONS		SEE SHEET 6		DOCUMENT NO. SD-93170-001		SHEET NO. 1 OF 7			

THIS DRAWING CONTAINS INFORMATION THAT IS PROPRIETARY TO MOLEX INCORPORATED AND SHOULD NOT BE USED WITHOUT WRITTEN PERMISSION

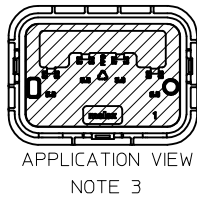
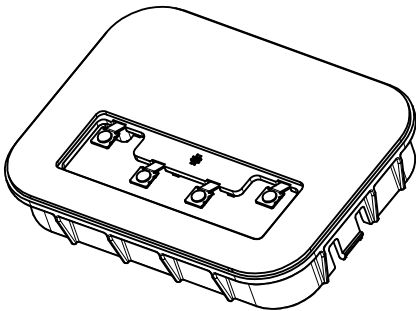
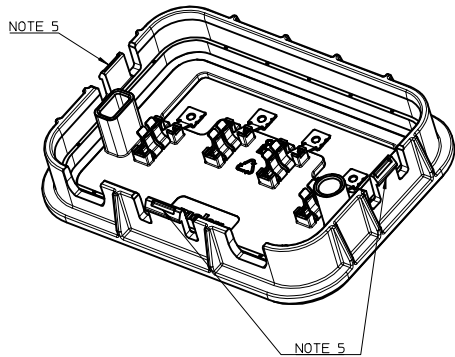

NOTES:

- PANEL ASSEMBLY TERMINALS COME WITH OR WITHOUT SOLDER (SEE SHEET 5 FOR OPTIONS). CUSTOMER MUST APPLY FLUX BEFORE SOLDERING TO CLEAN JOINT AREA. SOLDER CHARGE POSITION MEASURED RELATIVE TO HOUSING. FOR PARTS WITHOUT SOLDER CHARGE, DIMENSION 63 BECOMES 0.95±0.10
- DOUBLE-SIDED TAPE FOR ADHESION TO PANEL. WINDOW FOR TERMINALS WILL BE CLOSED WITH EXISTING CARRIER TAPE.
- APPLY 10-15N/cm² (15-22psi) PRESSURE TO ENSURE CORRECT ADHESION. PRESSURE TO BE APPLIED TO INNER SURFACE OF PANEL HOUSING (SEE HATCHED AREA IN APPLICATION VIEW).
- ALIGNMENT FEATURES FOR GUIDING APPLICATION TOOLING (PRESS TOOL AND SOLDERING TOOL).
- LATCHES FOR RETENTION OF COVER ASSEMBLY.
- ALL DIMENSIONS OTHER THAN FOR TAPE, APPLY TO SILICONE VERSIONS ALSO (SEE SHEET 3).

INSPECTION NUMBERS RESERVED FOR SHEET 2: 51-100
LAST INSPECTION NUMBER USED: 63

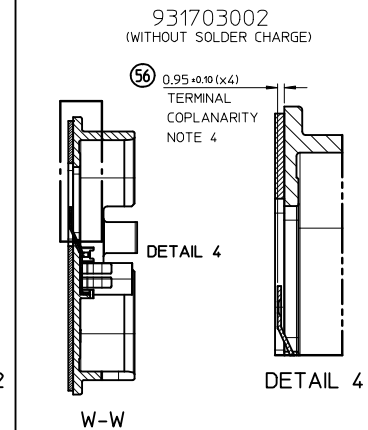
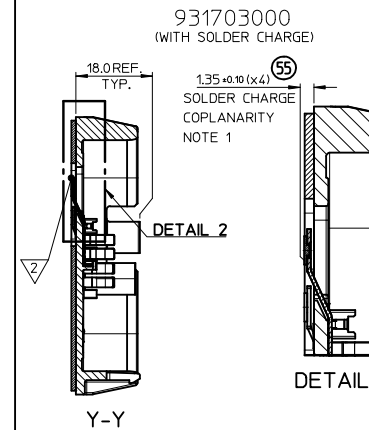
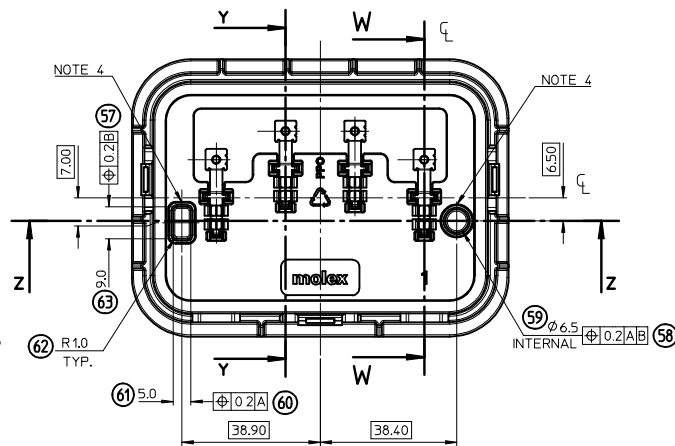
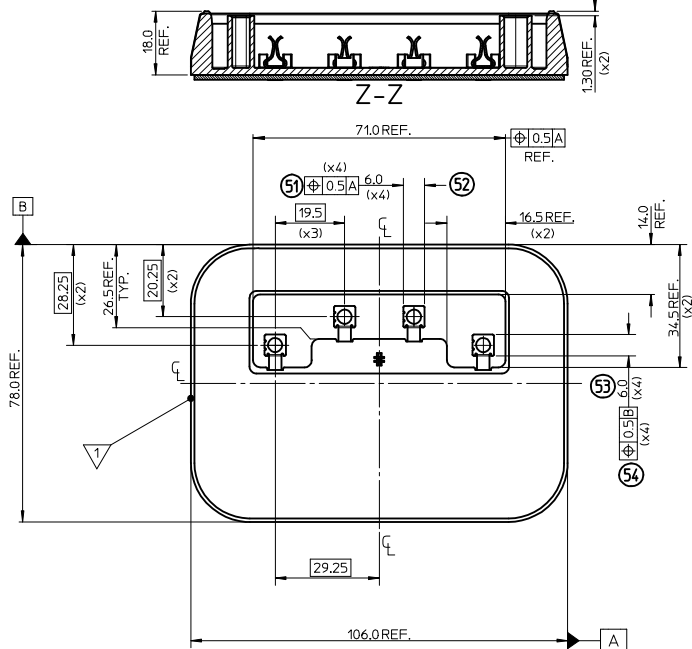

ITEM	DESCRIPTION	QTY	ITEM	DESCRIPTION	QTY
▽	HOUSING	1	▽	HOUSING	1
▽	PANEL TERM W/ SLDR CHARGE	4	▽	PANEL TERM PLATED	4
▽	DOUBLE-SIDED TAPE	1	▽	DOUBLE-SIDED TAPE	1

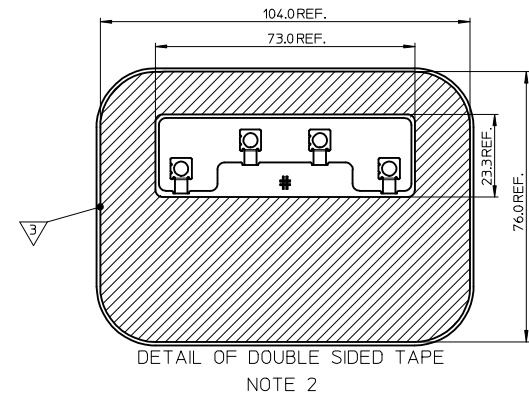

SEE SHEET 1 EC NO: E2009-0584 DRAWN: SMC GREEVY 2009/09/01 CHKD: 2009/09/02 APPR: EFOLAN 2009/09/02	QUALITY SYMBOLS ▽=0 ▽=0	GENERAL TOLERANCES (UNLESS SPECIFIED)		DIMENSION STYLE MM ONLY		SCALE 1:1	DESIGN UNITS METRIC	THIRD ANGLE PROJECTION
		4 PLACES ± --- ± --- 3 PLACES ± --- ± --- 2 PLACES ± 0.10 ± --- 1 PLACE ± 0.2 ± --- ANGULAR ± 2 °	mm INCH ± --- ± --- ± 0.10 ± --- ± 0.2 ± ---	DRAWN BY MSHANAHAN DATE 2008/7/11	DATE 2008/7/11	TITLE JUNCTION BOX FOR P.V. SOLAR PANEL		
DRAFT WHERE APPLICABLE MUST REMAIN WITHIN DIMENSIONS	SEE SHEET 6	MATERIAL NO. EFOLAN		DATE 2008/7/11		MOLEX INCORPORATED		
		DOCUMENT NO. SD-93170-001		SHEET NO. 2 OF 7		THIS DRAWING CONTAINS INFORMATION THAT IS PROPRIETARY TO MOLEX INCORPORATED AND SHOULD NOT BE USED WITHOUT WRITTEN PERMISSION		

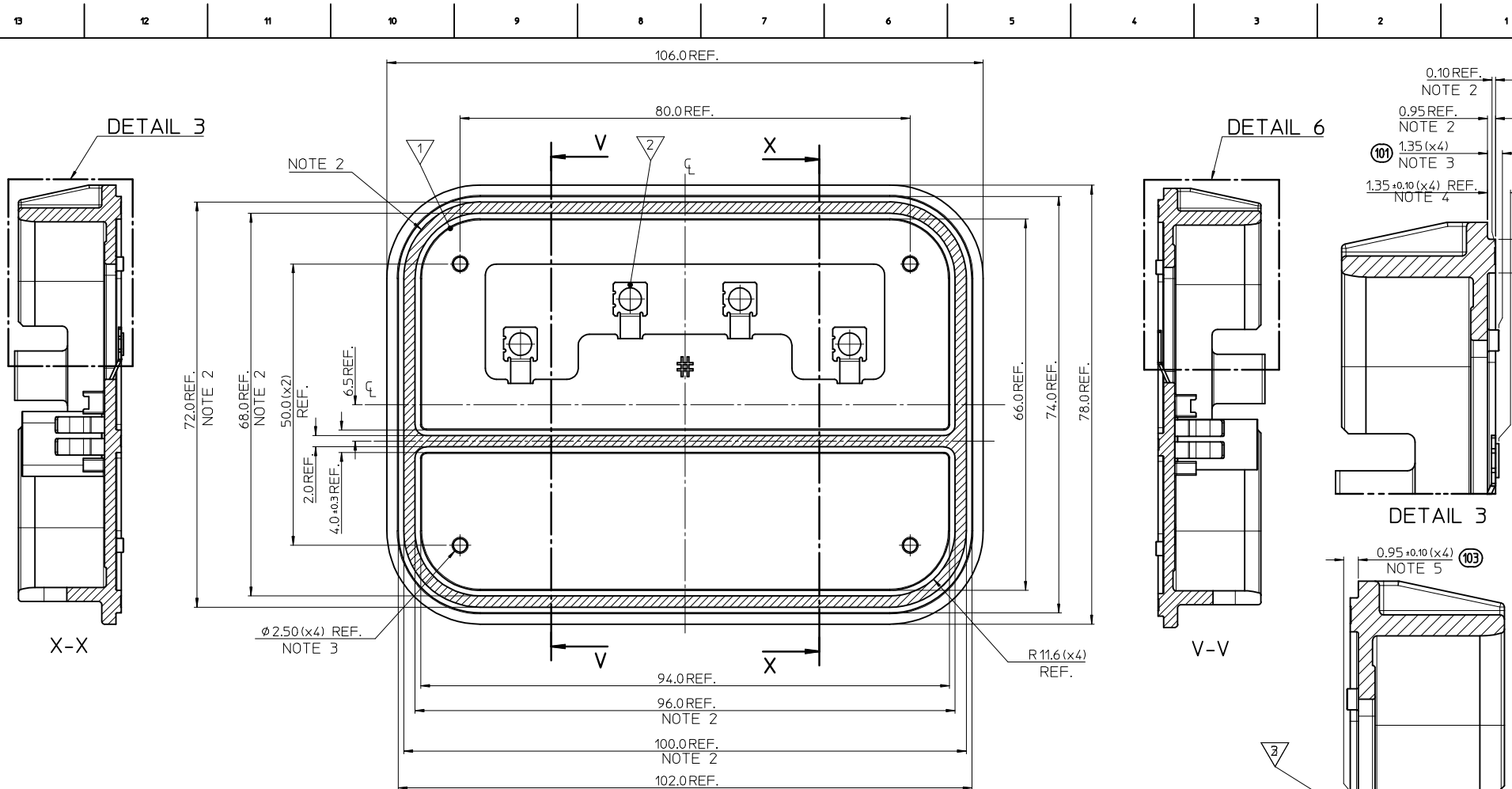

- NOTES:
1. DIMENSIONS APPLY TO SILICONE VERSIONS OF PANEL ASSEMBLIES ONLY.
ALL OTHER DIMENSIONS SEE SHEETS 1 & 2
 2. HATCHED AREA SHOWS DETAIL OF GROOVE FOR SILICONE APPLICATION.
GROOVE SITUATED IN RAISED PLASTIC WALL TO ACCOMODATE TERMINALS.
 3. 4x STAND-OFFS TO GIVE 0.5mm GAP FOR SILICONE INCLUSIVE OF GROOVE.
 4. TERMINAL COPLANARITY AS PER DIMENSION 63 SHEET 2
 5. COPLANARITY FOR TERMINALS WITHOUT SOLDER CHARGE.

INSPECTION NUMBERS RESERVED FOR SHEET 3: 101-150
 DELETED INSPECTION NUMBER: 102
 LAST INSPECTION NUMBER USED: 103

931703001			931703003		
ITEM	DESCRIPTION	QTY	ITEM	DESCRIPTION	QTY
▽	HOUSING	1	▽	HOUSING	1
▽	PANEL TERM W/ SLDR CHARGE	4	▽	PANEL TERM W/O SLDR CHARGE	4

SEE SHEET 1 EC NO: E2009-0584 DRAWN: SMC GREEVY 2009/09/01 CHKD: SMC GREEVY 2009/09/02 APPR: EFOLAN 2009/09/02	QUALITY SYMBOLS	GENERAL TOLERANCES (UNLESS SPECIFIED)	DIMENSION STYLE	SCALE	DESIGN UNITS	THIRD ANGLE PROJECTION
	▽=0	mm INCH	MM ONLY	2:1	METRIC	
	▽=0	4 PLACES ± --- ± ---	DRAWN BY DATE	TITLE JUNCTION BOX FOR P.V. SOLAR PANEL		
		3 PLACES ± --- ± ---	MSHANAHAN 2008/7/11			
	2 PLACES ± 0.10 ± ---	CHECKED BY DATE	MOLEX INCORPORATED MATERIAL NO. SD-93170-001 DOCUMENT NO. 3 OF 7			
	1 PLACE ± 0.2 ± ---	SMCGREEVY 2008/7/11				
	ANGULAR ± 2 °	APPROVED BY DATE	THIS DRAWING CONTAINS INFORMATION THAT IS PROPRIETARY TO MOLEX INCORPORATED AND SHOULD NOT BE USED WITHOUT WRITTEN PERMISSION			
		EFOLAN 2008/7/11				
	DRAFT WHERE APPLICABLE MUST REMAIN WITHIN DIMENSIONS	SIZE				
		A 2				

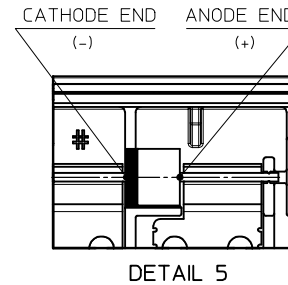
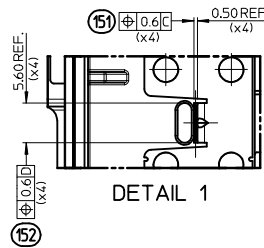
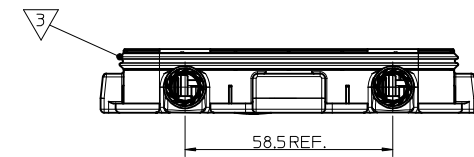
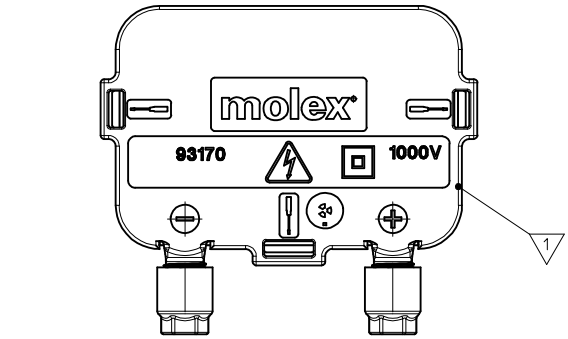
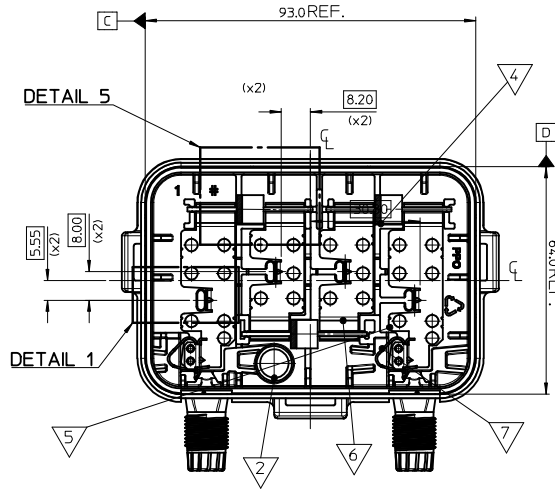
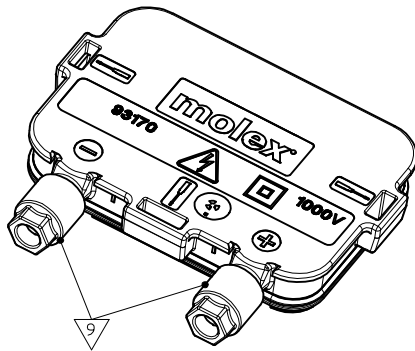
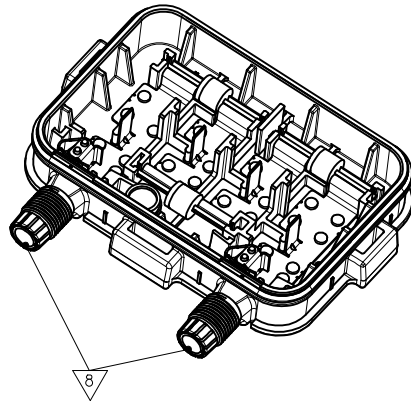

NOTES:

1. SEPARATE COVER ASSEMBLY FROM BASE BY OPENING RETENTION CLIPS WITH SCREWDRIVER.
2. PRESSURE EQUALISATION AND BREATHABILITY VENT.
3. SILICONE SEAL: SHORE HARDNESS: 30A
4. DIODES SOLDERED TO TERMINALS TO GIVE BEST HEAT REMOVAL PERFORMANCE.
5. TERMINALS HEAT STAKED INTO HOUSING. LARGE SURFACE AREA FOR HEAT DISSIPATION.
6. INSERT CABLE BY OPENING CABLE CLAMP WITH LONG-NOSE PLIERS.
7. PARTS SUPPLIED WITH OR WITHOUT CABLES (SEE SHEET 6)
8. PARTS SUPPLIED WITH GROMMETS INSTALLED. FOR JUNCTION BOX ONLY ASSEMBLIES, M12 NUT WILL BE SUPPLIED INSTALLED BUT NOT TIGHTENED.
9. FOR PART NUMBER OPTIONS SEE SHEET 6

INSPECTION NUMBERS RESERVED FOR SHEET 3: 151-200
LAST INSPECTION NUMBER USED: 152

9317040XX			
ITEM	DESCRIPTION	QTY	NOTE
1	COVER HOUSING	1	1
2	BREATHABLE VENT	1	2
3	SILICONE SEAL	1	3
4	DIODE	3	4
5	TERMINAL (OUTER)	2	5
6	TERMINAL (CENTRE)	2	5
7	CABLE SPRING CLAMP	2	6
8	SILICONE GROMMET	2	7
9	M12 NUT	2	8

SEE SHEET 1 EC NO: E2009-0584 DRAWN: SMCREEVY 2009/09/01 CHKD: SMCREEVY 2009/09/02 APPR: EFOLAN 2009/09/02	QUALITY SYMBOLS ▽=0 ▽=0	GENERAL TOLERANCES (UNLESS SPECIFIED)		DIMENSION STYLE MM ONLY		SCALE 1:1	DESIGN UNITS METRIC	THIRD ANGLE PROJECTION			
		4 PLACES ± --- ± ---	3 PLACES ± --- ± ---	2 PLACES ± 0.10 ± ---	1 PLACE ± 0.2 ± ---	DRAWN BY MSHANAHAN	DATE 2008/7/11	TITLE JUNCTION BOX FOR P.V. SOLAR PANEL			
		ANGULAR ± 2 °				CHECKED BY SMCREEVY	DATE 2008/7/11	MOLEX INCORPORATED			
		DRAFT WHERE APPLICABLE MUST REMAIN WITHIN DIMENSIONS				APPROVED BY EFOLAN	DATE 2008/7/11	MATERIAL NO. SEE SHEET 6	DOCUMENT NO. SD-93170-001	SHEET NO. 4 OF 7	

THIS DRAWING CONTAINS INFORMATION THAT IS PROPRIETARY TO MOLEX INCORPORATED AND SHOULD NOT BE USED WITHOUT WRITTEN PERMISSION

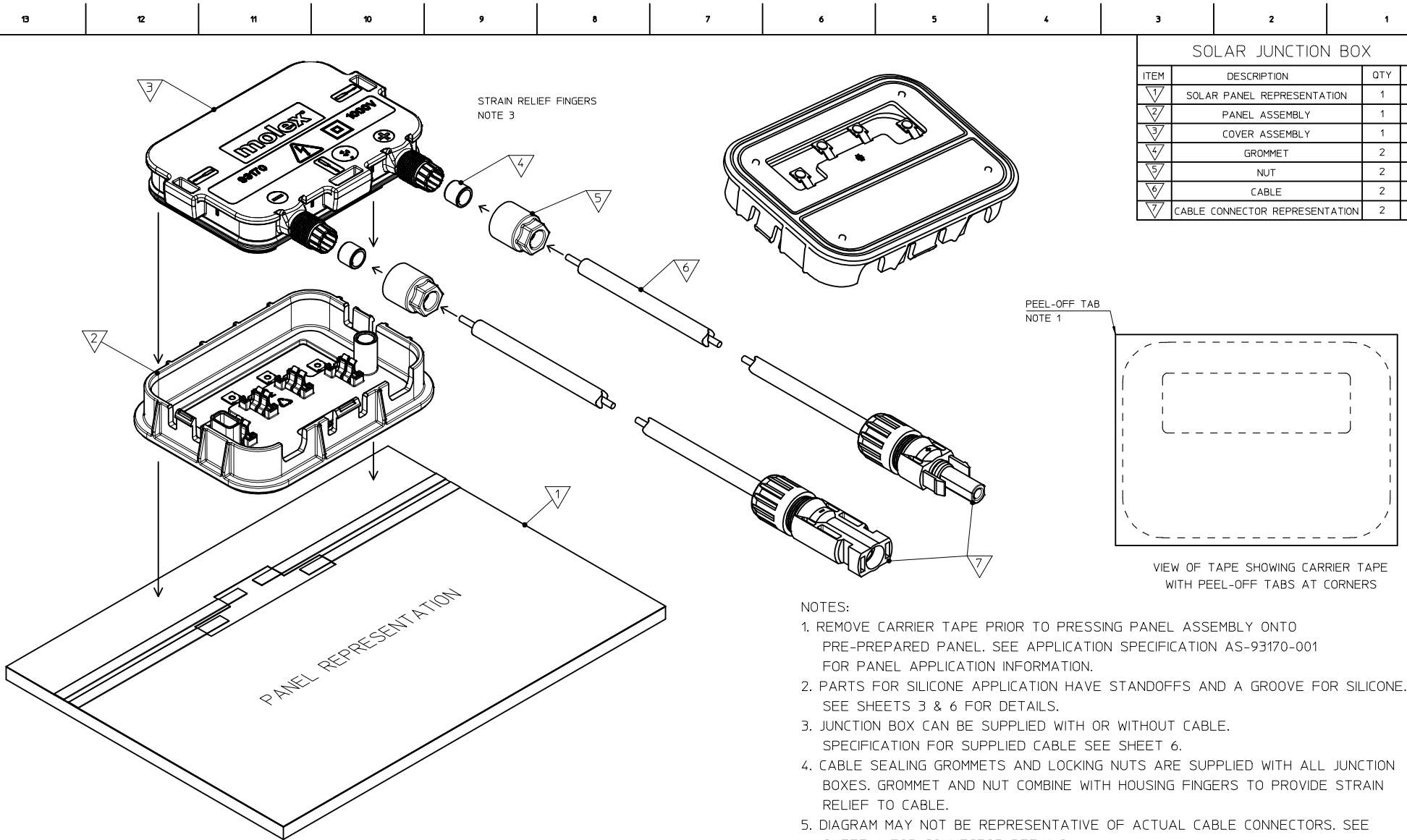

SOLAR JUNCTION BOX			
ITEM	DESCRIPTION	QTY	NOTE
▽	SOLAR PANEL REPRESENTATION	1	
▽	PANEL ASSEMBLY	1	
▽	COVER ASSEMBLY	1	
▽	GROMMET	2	4
▽	NUT	2	4
▽	CABLE	2	3
▽	CABLE CONNECTOR REPRESENTATION	2	5

PEEL-OFF TAB
NOTE 1

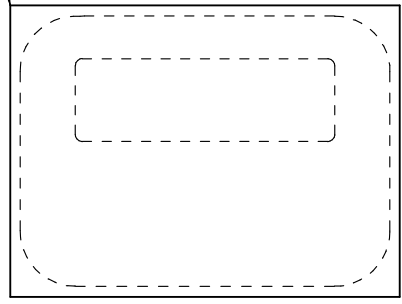

VIEW OF TAPE SHOWING CARRIER TAPE WITH PEEL-OFF TABS AT CORNERS

NOTES:

1. REMOVE CARRIER TAPE PRIOR TO PRESSING PANEL ASSEMBLY ONTO PRE-PREPARED PANEL. SEE APPLICATION SPECIFICATION AS-93170-001 FOR PANEL APPLICATION INFORMATION.
2. PARTS FOR SILICONE APPLICATION HAVE STANDOFFS AND A GROOVE FOR SILICONE. SEE SHEETS 3 & 6 FOR DETAILS.
3. JUNCTION BOX CAN BE SUPPLIED WITH OR WITHOUT CABLE. SPECIFICATION FOR SUPPLIED CABLE SEE SHEET 6.
4. CABLE SEALING GROMMETS AND LOCKING NUTS ARE SUPPLIED WITH ALL JUNCTION BOXES. GROMMET AND NUT COMBINE WITH HOUSING FINGERS TO PROVIDE STRAIN RELIEF TO CABLE.
5. DIAGRAM MAY NOT BE REPRESENTATIVE OF ACTUAL CABLE CONNECTORS. SEE SHEET 6 FOR CONNECTOR DETAILS.

SEE SHEET 1 EC NO: E2009-0584 DRWN:SMCGREEVY 2009/09/01 CHKD: 2009/09/02 APPR:EFOLAN 2009/09/02	QUALITY SYMBOLS	GENERAL TOLERANCES (UNLESS SPECIFIED)	DIMENSION STYLE	SCALE	DESIGN UNITS	THIRD ANGLE PROJECTION
	▽=0	mm INCH	MM ONLY	1:1	METRIC	
	▽=0	4 PLACES ± --- ± ---	DRAWN BY DATE	TITLE		
		3 PLACES ± --- ± ---	MSHANAHAN 2008/7/11	JUNCTION BOX FOR P.V. SOLAR PANEL		
	2 PLACES ± 0.10 ± ---	CHECKED BY DATE	MOLEX INCORPORATED			
	1 PLACE ± 0.2 ± ---	SMCGREEVY 2008/7/11	MATERIAL NO. DOCUMENT NO.			
	ANGULAR ± 2 °	APPROVED BY DATE	SD-93170-001			
		EFOLAN 2008/7/11	SHEET NO. 5 OF 7			
	DRAFT WHERE APPLICABLE MUST REMAIN WITHIN DIMENSIONS	SIZE	THIS DRAWING CONTAINS INFORMATION THAT IS PROPRIETARY TO MOLEX INCORPORATED AND SHOULD NOT BE USED WITHOUT WRITTEN PERMISSION			
		A 2				

TABLE 1	FULL ASSEMBLY →	9317010XX	9317011XX	9317012XX	9317013XX	9317014XX	9317015XX	9317016XX	9317017XX	9317018XX	9317019XX	9317020XX	9317021XX
	PANEL ASSEMBLY	QTY	QTY	QTY	QTY	QTY	QTY	QTY	QTY	QTY	QTY	QTY	QTY
931703000	①	-	-	-	①	-	-	-	①	-	-	-	
931703001	-	①	-	-	-	①	-	-	-	①	-	-	
931703002	-	-	①	-	-	-	①	-	-	-	①	-	
931703003	-	-	-	①	-	-	-	①	-	-	-	①	
COVER ASSEMBLY													
9317040XX	①	①	①	①	-	-	-	-	-	-	-	-	
9317041XX	-	-	-	-	①	①	①	①	-	-	-	-	
9317042XX	-	-	-	-	-	-	-	-	①	①	①	①	

TABLE 2a	PANEL ASSEMBLY	DESCRIPTION
931703000	4-POLE PANEL ASSY WITH DOUBLE SIDED TAPE AND SOLDER CHARGE	
931703001	4-POLE PANEL ASSY WITH SOLDER CHARGE FOR SILICONE APPLICATIONS	
931703002	4-POLE PANEL ASSY WITH DOUBLE SIDED TAPE, WITHOUT SOLDER CHARGE	
931703003	4-POLE PANEL ASSY WITHOUT SOLDER CHARGE FOR SILICONE APPLICATIONS	

TABLE 2b	COVER ASSEMBLY	DIODE QUANTITY	CABLE MANUFACTURER	CABLE TYPE	CABLE LENGTH	CONNECTOR TYPE
9317040XX	3x BYPASS	LEONI	STUDER BETAFLAM 4mm ²	NOTES 5 & 6	MC4	
9317041XX	3x BYPASS	TBC	TUV/UL APPROVED CABLE 4mm ²	NOTES 5 & 6	TUV/UL APPROVED	
9317042XX	3x BYPASS	TBC	TUV/UL APPROVED CABLE 4mm ²	NOTES 5 & 6	TUV/UL APPROVED	

HOW TO CHOOSE YOUR JUNCTION BOX

- 1 CHOOSE YOUR PANEL ASSEMBLY OPTION FROM TABLE 2a
(E.G. FOR PANEL ASSY WITH SOLDER CHARGE AND WITH DOUBLE SIDED TAPE CHOOSE 931703000)
- 2 CHOOSE COVER ASSEMBLY OPTION FROM TABLE 2b
(NOTE: DIFFERENT CABLE TYPES DIFFERENTIATED IN TABLE 2b BY DIGIT #7)
- 3 FIND COLUMN IN TABLES 2a & 2b WHERE BOTH PART NUMBERS ARE CONTAINED.
- 4 READ FULL ASSEMBLY PART NUMBER BODY IN SAME COLUMN IN TABLE 1.
- 5 SUBSTITUTE CABLE LENGTH FOR LAST 2 DIGITS (XX) WITHOUT DECIMAL PLACE.
(DIMENSION "A" SHEET 7)

E.G. 931701009 = 4-POLE JUNCTION BOX WITH DOUBLE SIDED TAPE & SOLDER CHARGE WITH 0.9m LENGTHS OF LEONI CABLE AND WITH MC4 CONNECTORS.

- 6 FOR PARTS WITHOUT CABLE, SUBSTITUTE "00" FOR "XX"

E.G. 931701000 = 4-POLE JUNCTION BOX WITH DOUBLE SIDED TAPE & SOLDER CHARGE WITHOUT CABLES AND.

NOTES:

1. PARTS CAN BE ORDERED AS FULL ASSEMBLIES OR AS SEPARATE SUB-ASSEMBLIES
2. PACKAGING:
 - PANEL ASSEMBLY: TRAYS
 - COVER ASSEMBLY: IN BOXES
 - SEE PACKAGING SPECIFICATION: PK-93170-001
3. ASSEMBLIES WITH CABLES COME WITH 1 POSITIVE AND 1 NEGATIVE CABLE ATTACHED
4. FOR SELF ASSEMBLED CABLES NUTS SHOULD BE TIGHTENED TO TORQUE OF 1.25-1.50Nm

SEE SHEET 1 EC NO: E2009-0584 DRAWN: SMCREEVY 2009/09/01 CHKD: 2009/09/02 APPR: E.FOLAN 2009/09/02	QUALITY SYMBOLS	GENERAL TOLERANCES (UNLESS SPECIFIED)	DIMENSION STYLE	SCALE	DESIGN UNITS	THIRD ANGLE PROJECTION
	▽=0	mm INCH	MM ONLY	1:1	METRIC	
	▽=0	4 PLACES ± --- ± ---	DRAWN BY DATE	TITLE		
		3 PLACES ± --- ± ---	MSHANAHAN 2008/7/11	JUNCTION BOX FOR P.V. SOLAR PANEL		
	2 PLACES ± 0.10 ± ---	CHECKED BY DATE	MATERIAL NO.			
	1 PLACE ± 0.2 ± ---	SMCGREEVY 2008/7/11	DOCUMENT NO.			
	ANGULAR ± 2 °	APPROVED BY DATE	SHEET NO.			
		E.FOLAN 2008/7/11	6 OF 7			
	DRAFT WHERE APPLICABLE MUST REMAIN WITHIN DIMENSIONS		MOLEX INCORPORATED			
			SD-93170-001			
			THIS DRAWING CONTAINS INFORMATION THAT IS PROPRIETARY TO MOLEX INCORPORATED AND SHOULD NOT BE USED WITHOUT WRITTEN PERMISSION			

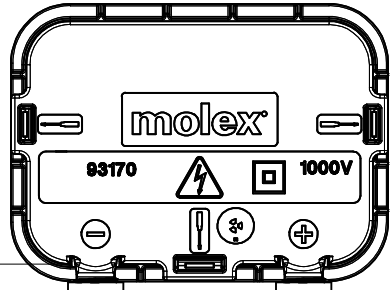

DIMENSION *A* (x2)

NEGATIVE
CONNECTOR

POSITIVE
CONNECTOR

NOTES:

1. CABLE LENGTH MEASURED FROM BOX TO BACK END OF CONNECTOR.
2. DIMENSION *A* CONTROLLED BY CHOSEN PART NUMBER. SEE SHEET 6 FOR DETAILS OF HOW TO SELECT REQUIRED LENGTH.

SEE SHEET 1 EC NO: E2009-0584 DRAWN: SMCREEVY 2009/09/01 CHKD: 2009/09/02 APPR: EFOLAN 2009/09/02	DESCRIPTION REV	QUALITY SYMBOLS ▽=0 ▽=0		GENERAL TOLERANCES (UNLESS SPECIFIED) <table border="1"> <thead> <tr> <th></th> <th>mm</th> <th>INCH</th> </tr> </thead> <tbody> <tr> <td>4 PLACES</td> <td>± ---</td> <td>± ---</td> </tr> <tr> <td>3 PLACES</td> <td>± ---</td> <td>± ---</td> </tr> <tr> <td>2 PLACES</td> <td>± 0.10</td> <td>± ---</td> </tr> <tr> <td>1 PLACE</td> <td>± 0.2</td> <td>± ---</td> </tr> <tr> <td colspan="3">ANGULAR ± 2 °</td> </tr> </tbody> </table>			mm	INCH	4 PLACES	± ---	± ---	3 PLACES	± ---	± ---	2 PLACES	± 0.10	± ---	1 PLACE	± 0.2	± ---	ANGULAR ± 2 °			DIMENSION STYLE MM ONLY		SCALE 1:1	DESIGN UNITS METRIC	THIRD ANGLE PROJECTION
			mm	INCH																								
4 PLACES	± ---	± ---																										
3 PLACES	± ---	± ---																										
2 PLACES	± 0.10	± ---																										
1 PLACE	± 0.2	± ---																										
ANGULAR ± 2 °																												
DRAFT WHERE APPLICABLE MUST REMAIN WITHIN DIMENSIONS				DRAWN BY MSHANAHAN		DATE 2008/7/11		TITLE JUNCTION BOX FOR P.V. SOLAR PANEL																				
				CHECKED BY SMCREEVY		DATE 2008/7/11																						
				APPROVED BY EFOLAN		DATE 2008/7/11		MOLEX INCORPORATED																				
				MATERIAL NO.		DOCUMENT NO.		SHEET NO.																				
				SHEET 6		SD-93170-001		7 OF 7																				
				SIZE A2 THIS DRAWING CONTAINS INFORMATION THAT IS PROPRIETARY TO MOLEX INCORPORATED AND SHOULD NOT BE USED WITHOUT WRITTEN PERMISSION																								