

MPR SERIES

32332628
Issue K

MicroPressure Board Mount Pressure Sensors Compact, High Accuracy, Compensated/Amplified

DESCRIPTION

The MPR Series is a very small piezoresistive silicon pressure sensor offering a digital output for reading pressure over the specified full scale pressure span and temperature range. It is calibrated and compensated over a specific temperature range for sensor offset, sensitivity, temperature effects, and non-linearity using an on-board Application Specific Integrated Circuit (ASIC). This product is designed to meet the requirements of higher volume medical (consumer and non-consumer) devices, commercial appliance, and industrial/HVAC applications.

DIFFERENTIATION

- Application-specific design addresses various application needs and challenges.
- Digital output: Plug and play feature enables ease of implementation and system level connectivity.
- Total Error Band: Provides a more comprehensive measurement of performance over the compensated temperature range, which minimizes testing and calibrating every sensor, thereby potentially reducing manufacturing cost; improves sensor accuracy and offers ease of sensor interchangeability due to minimal part-to-part variation. (See Figure 1.)

VALUE TO CUSTOMERS

- Very small form factor: Enables portability by addressing weight, size, and space restrictions; occupies less area on the PCB.
- Wide pressure ranges simplify use.
- Enhances performance: Output accelerates performance through reduced conversion requirements and direct interface to microprocessors.
- Value solution: Cost-effective, higher volume solution with configurable options.

- Meets IPC/JEDEC J-STD-020D.1 Moisture Sensitivity Level 1 requirements: Allows avoidance of thermal and mechanical damage during solder reflow attachment and/or repair that lesser rated sensors may incur; allows long floor life when stored as specified (simplifying storage and reducing scrap); eliminates lengthy bakes prior to reflow, and allows for lean manufacturing due to stability and usability shortly after reflow.
- Meets food safety certification for North America, Europe and Asia (see Table 2).

POTENTIAL APPLICATIONS

- **Consumer medical:** Non-invasive blood pressure monitoring, negative-pressure wound therapy, breast pumps, mobile oxygen concentrators, airflow monitors, CPAP water tanks, and medical wearables
- **Non-consumer medical:** Invasive blood pressure monitors, ambulatory blood pressure measurement, urine analyzers
- **Industrial:** Air braking systems, gas and water meters, natural gas metering, process gas monitoring, gas burner control, air compressors, gray water tank level measurement
- **Consumer:** Coffee machines, humidifiers, air beds, washing machines, dishwashers
- **Transportation:** CNG level monitoring, fuel level measurement

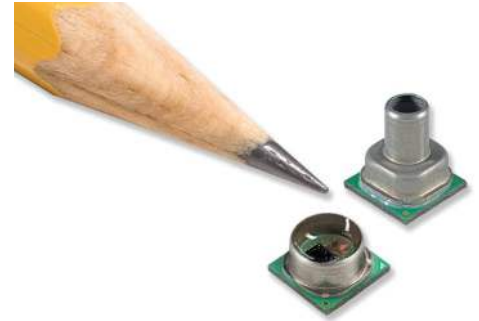

FEATURES

- 5 mm x 5 mm [0.20 in x 0.20 in] package footprint
- Calibrated and compensated
- 60 mbar to 2.5 bar | 6 kPa to 250 kPa | 1 psi to 30 psi
- 24-bit digital I²C or SPI-compatible output
- IoT (Internet of Things) ready interface
- Stainless steel pressure port
- Compatible with a variety of liquid media
- Absolute and gage pressure types
- Total Error Band after customer auto-zero: As low as ± 1.25 %FSS
- Compensated temperature range: 0°C to 50°C [32°F to 122°F]
- REACH and RoHS compliant
- Meets IPC/JEDEC J-STD-020D.1 Moisture Sensitivity Level 1
- Select sensors available on breakout board for easy evaluation and testing
- Ultra-low power consumption (as low as 0.01 mW typ. average power, 1 Hz measurement frequency)
- Sensor materials have been tested and certified for these food safety standards: BPA Free, LFGB, NSF-169

PORTFOLIO



The MPR Series joins an extensive line of board mount pressure sensors for potential use in medical, industrial, and consumer applications. To view the entire product portfolio, [click here](#).

Honeywell

MICROPRESSURE BOARD MOUNT PRESSURE SENSORS

MPR SERIES

Table of Contents

General Specifications	3-4
Power Consumption and Standby Mode	5-6
Product Nomenclature and Order Guide	7
Pressure Range Specifications:	
60 mbar to 2.5 bar	8
6 kPa to 250 kPa	9
1 psi to 30 psi	10
0 mmHg to 300 mmHg	10
1.0 GENERAL INFORMATION	11
2.0 PINOUT AND FUNCTIONALITY	11
3.0 START-UP TIMING	11
4.0 POWER SUPPLY REQUIREMENT	11
5.0 REFERENCE CIRCUIT DESIGN	12
5.1 I ² C and SPI Circuit Diagrams	12
5.2 Bypass Capacitor Use	12
6.0 I²C COMMUNICATIONS	
6.1 I ² C Bus Configuration	13
6.2 I ² C Data Transfer	13
6.3 I ² C Sensor Address	13
6.4 I ² C Pressure Reading	14
6.5 I ² C Status Byte	14
6.6 I ² C Communications	14
6.6.1 Output Measurement Command	14
6.6.2 I ² C Sensor Address of 0x18	15
6.7 I ² C Timing and Level Parameters	15
6.8 Reference Code (Arduino/Genuino Uno) for I ² C Interface	16
7.0 SPI COMMUNICATIONS	
7.1 SPI Definition	17
7.2 SPI Data Transfer	17
7.3 SPI Pressure Reading	17
7.4 SPI Status Byte	18
7.5 SPI Communications	18
7.6 SPI Timing and Level Parameters	18
7.7 Reference Code (Arduino/Genuino Uno) for SPI Interface	19
8.0 MPR SERIES DIGITAL OUTPUT PRESSURE CALCULATION	20
Long Port Dimensions and Recommended PCB Pad Layout	21
Short Port Dimensions and Recommended PCB Pad Layout	22
Tape and Reel Dimensions	23
Reflowable Protective Silicone Cap	24
Reflowable Protective Silicone Cap Removal	24
Recommended Tubing	24
Recommended O-Rings	25
Additional Information	back

MICROPRESSURE BOARD MOUNT PRESSURE SENSORS MPR SERIES

FIGURE 1. TEB COMPONENTS FOR THE MPR SERIES

Total Error Band (TEB) is a single specification that includes the major sources of sensor error. TEB should not be confused with accuracy, which is actually a component of TEB. TEB is the worst error that the sensor could experience.

Honeywell uses the TEB specification in its datasheet because it is the most comprehensive measurement of a sensor’s true accuracy. Honeywell also provides the accuracy specification in order to provide a common comparison with competitors’ literature that does not use the TEB specification.

Many competitors do not use TEB—they simply specify the accuracy of their device. Their accuracy specification, however, may exclude certain parameters. On their datasheet, the errors are listed individually. When combined, the total error (or what would be TEB) could be significant.

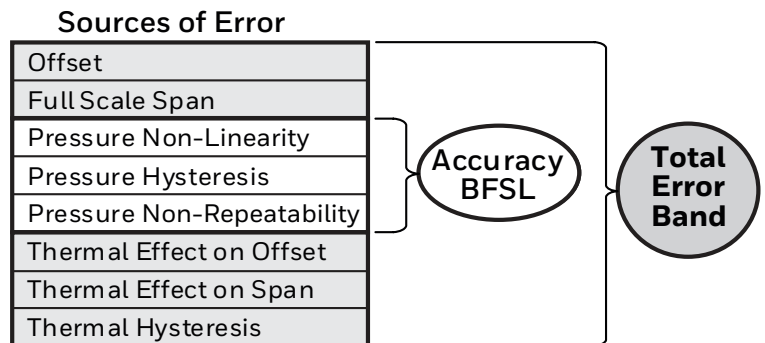

TABLE 1. ABSOLUTE MAXIMUM RATINGS¹

Characteristic	Minimum	Maximum	Unit
Supply voltage (V_{supply})	-0.3	3.6	Vdc
Voltage on any pin	-0.3	$V_{supply} + 0.3$	V
ESD susceptibility (human body model)	—	4	kV
Storage temperature	-40 [-40]	85 [185]	°C [°F]
Soldering peak reflow temperature and time	15 s max. at 250°C [482°F]		

¹Absolute maximum ratings are the extreme limits the device will withstand without damage.

TABLE 2. ENVIRONMENTAL SPECIFICATIONS

Characteristic	Parameter
Humidity: external surfaces internal surfaces	0 %RH to 95 %RH, non-condensing 0 %RH to 100 %RH, condensing
Vibration	10 g, 10 Hz to 2 kHz
Shock	50 g, 6 ms duration
Solder reflow	J-STD-020-D.1 Moisture Sensitivity Level 1 (unlimited shelf life when stored at $\leq 30^{\circ}\text{C}/85\% \text{RH}$)
Certification (food grade gel coating option)	NSF-169, BPA Free, LFGB

TABLE 3. WETTED MATERIALS

Component	Material
Port	304 stainless steel
Adhesives	epoxy, silicone gel, fluorosilicone gel
Electronic components	silicon, glass, gold, aluminum
Metal gel ring	304 stainless steel

MICROPRESSURE BOARD MOUNT PRESSURE SENSORS

MPR SERIES

TABLE 4. SENSOR PRESSURE TYPES

Pressure Type	Description
Absolute	Output is proportional to the difference between applied pressure and a built-in vacuum reference.
Gage	Output is proportional to the difference between applied pressure and atmospheric (ambient) pressure.

TABLE 5. OPERATING SPECIFICATIONS

Characteristic	Minimum	Typical	Maximum	Unit
Supply voltage (V_{supply}): ¹	1.8	3.3	3.6	Vdc
Current consumption:				
I ² C sleep/standby mode	3.0	33.8	211	nA
SPI sleep/standby mode	13.0	43.8	221.0	nA
Power consumption	—	10	—	mW
Operating temperature range ²	-40 [-40]	—	85 [185]	°C [°F]
Compensated temperature range ³	0 [32]	—	50 [122]	°C [°F]
Startup time (power up to data ready)	—	—	2.5	ms
Data rate (assumes command AA _{HEX})	161	204	—	samples per second
I ² C/SPI voltage level:				
low	—	—	20	% V_{supply}
high	80	—	—	
Pull up on MISO, SCLK, SS, MOSI	1	—	—	kOhm
Accuracy ⁴	—	—	±0.25	%FSS BFSL ⁵
Resolution:				
transfer function A	14.0	—	—	bits
transfer function B	13.5	—	—	
transfer function C	14.0	—	—	

¹The sensor is not reverse polarity protected. Incorrect application of supply voltage or ground to the wrong pin may cause electrical failure.

²**Operating temperature range:** The temperature range over which the sensor will produce an output proportional to pressure.

³**Compensated temperature range:** The temperature range over which the sensor will produce an output proportional to pressure within the specified performance limits (Total Error Band).

⁴**Accuracy:** The maximum deviation in output from a Best Fit Straight Line (BFSL) fitted to the output measured over the pressure range. Includes all errors due to pressure non-linearity, pressure hysteresis, and non-repeatability.

⁵**Full Scale Span (FSS):** The algebraic difference between the output signal measured at the maximum (Pmax.) and minimum (Pmin.) limits of the pressure range. (See Figure 4 for pressure ranges.)

MICROPRESSURE BOARD MOUNT PRESSURE SENSORS MPR SERIES

POWER CONSUMPTION AND STANDBY MODE

The sensor is normally in Standby Mode and is only turned on in response to a user command, thus minimizing power consumption. Upon receiving the user command, the sensor wakes up from Standby Mode, runs a measurement in Active State, and automatically returns to Standby Mode, awaiting the next command. The resulting sensor power consumption is a function of the sampling rate (samples per second) as shown in Tables 6 and 7 and Figures 2 and 3.

TABLE 6. AVERAGE POWER CONSUMPTION AT 1.8 V_{SUPPLY} (ASSUMES COMMAND AA_{HEX})

Sampling Rate (samples per second)	Average Power (mW)	Active Time (ms)	Active Power (mW)	Idle Time (ms)	Idle Power (mW)
Minimum Average Power					
1	0.0068	3.625	1.884	996.375	0.0000054
2	0.0137	7.25	1.884	992.75	0.0000054
5	0.0341	18.125	1.884	981.875	0.0000054
10	0.0683	36.25	1.884	963.75	0.0000054
20	0.1366	72.5	1.884	963.75	0.0000054
50	0.3414	181.25	1.884	818.75	0.0000054
100	0.6829	362.5	1.884	637.5	0.0000054
160	1.0926	580	1.884	420	0.0000054
Typical Average Power					
1	0.0094	4.157	2.248	995.843	0.00006084
2	0.0187	8.314	2.248	991.686	0.00006084
5	0.0468	20.785	2.248	979.215	0.00006084
10	0.0935	41.57	2.248	958.43	0.00006084
20	0.1870	83.14	2.248	916.86	0.00006084
50	0.4673	207.85	2.248	792.15	0.00006084
100	0.9345	415.7	2.248	584.3	0.00006084
160	1.4592	665.12	2.248	334.88	0.00006084
Maximum Average Power					
1	0.0129	4.839	2.588	995.161	0.0003798
2	0.0254	9.678	2.588	990.322	0.0003798
5	0.0630	24.195	2.588	975.805	0.0003798
10	0.1256	48.39	2.588	951.61	0.0003798
20	0.2508	96.78	2.588	903.22	0.0003798
50	0.6264	241.95	2.588	758.05	0.0003798
100	1.2524	483.9	2.588	516.1	0.0003798
160	2.0036	774.24	2.588	225.76	0.0003798

FIGURE 2. AVERAGE POWER CONSUMPTION VS SAMPLING RATE AT 1.8 V_{SUPPLY}

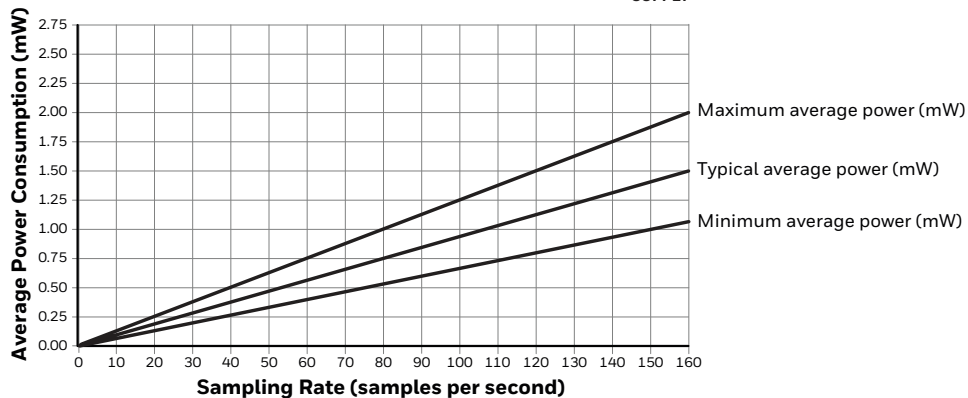

MICROPRESSURE BOARD MOUNT PRESSURE SENSORS

MPR SERIES

TABLE 7. AVERAGE POWER CONSUMPTION AT 3.3 V_{SUPPLY} (ASSUMES COMMAND AA_{HEX})

Sampling Rate (Samples per second)	Average Power (mW)	Active Time (ms)	Active Power (mW)	Idle Time (ms)	Idle Power (mW)
Minimum Average Power					
1	0.0114	3.625	3.134	996.375	0.0000099
2	0.0227	7.25	3.134	992.75	0.0000099
5	0.0568	18.125	3.134	981.875	0.0000099
10	0.1136	36.25	3.134	963.75	0.0000099
20	0.2272	72.5	3.134	963.75	0.0000099
50	0.5680	181.25	3.134	818.75	0.0000099
100	1.1361	362.5	3.134	637.5	0.0000099
160	1.8177	580	3.134	420	0.0000099
Typical Average Power					
1	0.0156	4.157	3.729	995.843	0.00011154
2	0.0311	8.314	3.729	991.686	0.00011154
5	0.0776	20.785	3.729	979.215	0.00011154
10	0.1551	41.57	3.729	958.43	0.00011154
20	0.3101	83.14	3.729	916.86	0.00011154
50	0.7751	207.85	3.729	792.15	0.00011154
100	1.5501	415.7	3.729	584.3	0.00011154
160	2.4800	665.12	3.729	334.88	0.00011154
Maximum Average Power					
1	0.0214	4.839	4.275	995.161	0.0006963
2	0.0421	9.678	4.275	990.322	0.0006963
5	0.1041	24.195	4.275	975.805	0.0006963
10	0.2075	48.39	4.275	951.61	0.0006963
20	0.4144	96.78	4.275	903.22	0.0006963
50	1.0349	241.95	4.275	758.05	0.0006963
100	2.0692	483.9	4.275	516.1	0.0006963
160	3.3103	774.24	4.275	225.76	0.0006963

FIGURE 3. AVERAGE POWER CONSUMPTION VS SAMPLING RATE AT 3.3 V_{SUPPLY}

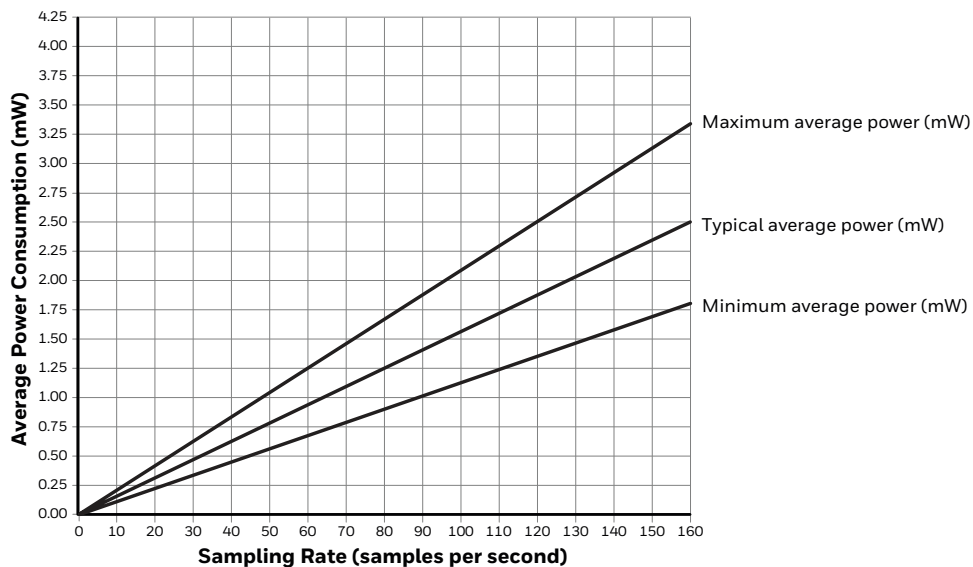

MICROPRESSURE BOARD MOUNT PRESSURE SENSORS MPR SERIES

FIGURE 4. PRODUCT NOMENCLATURE AND ORDER GUIDE

For example, **MPRLS0025PA00001A** defines an MPR Series pressure sensor, long port, silicone gel, 0 psi to 25 psi absolute pressure range, I²C, address 0x18, 10% to 90% of 2²⁴ counts transfer function, no breakout board.

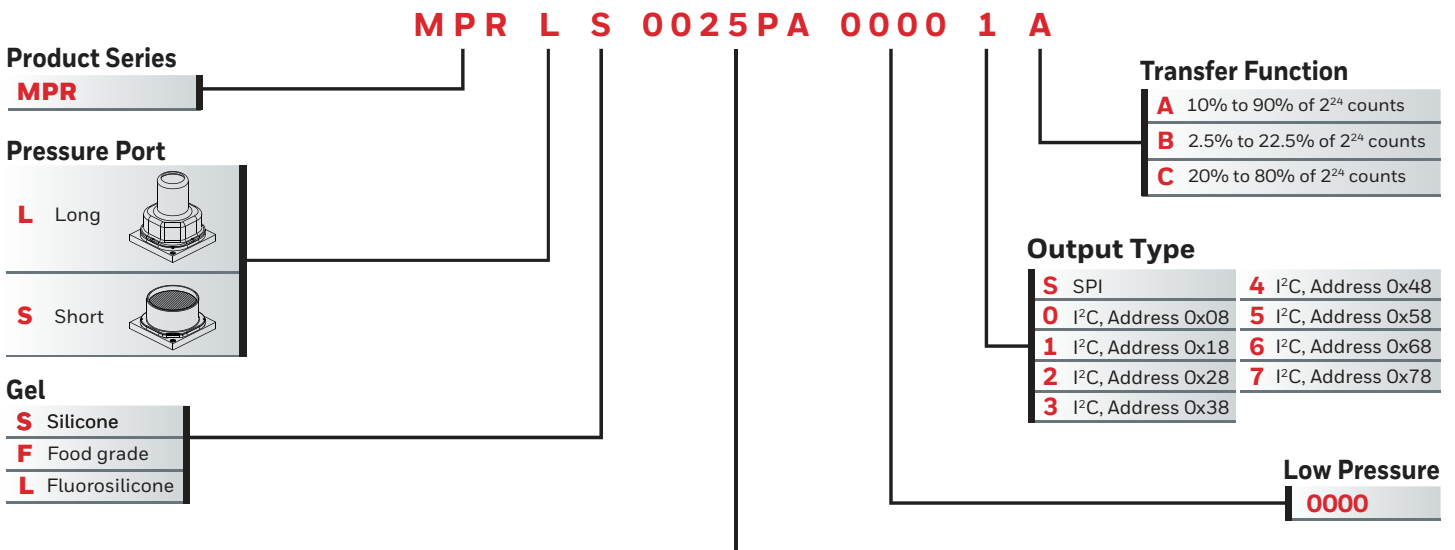

Pressure Range, Unit and Reference¹

Absolute		Absolute		Absolute		Gage	
0001BA	0 bar to 1 bar	0100KA	0 kPa to 100 kPa	0015PA	0 psi to 15 psi		
01.6BA	0 bar to 1.6 bar	0160KA	0 kPa to 160 kPa	0025PA	0 psi to 25 psi		
02.5BA	0 bar to 2.5 bar	0250KA	0 kPa to 250 kPa	0030PA	0 psi to 30 psi		
Gage		Gage		Gage		Gage	
0060MG	0 mbar to 60 mbar	0006KG	0 kPa to 6 kPa	0001PG	0 psi to 1 psi	0300YG	0 mmHg to 300 mmHg
0100MG	0 mbar to 100 mbar	0010KG	0 kPa to 10 kPa	0005PG	0 psi to 5 psi		
0160MG	0 mbar to 160 mbar	0016KG	0 kPa to 16 kPa	0015PG	0 psi to 15 psi		
0250MG	0 mbar to 250 mbar	0025KG	0 kPa to 25 kPa	0030PG	0 psi to 30 psi		
0400MG	0 bar to 400 mbar	0040KG	0 kPa to 40 kPa				
0600MG	0 bar to 600 mbar	0060KG	0 kPa to 60 kPa				
0001BG	0 bar to 1 bar	0100KG	0 kPa to 100 kPa	N	inH ₂ O	Other calibration units may be specified.	
01.6BG	0 bar to 1.6 bar	0160KG	0 kPa to 160 kPa	G	MPa		
02.5BG	0 bar to 2.5 bar	0250KG	0 kPa to 250 kPa	H	hPa		
				C	cmH ₂ O		

¹ Custom pressure ranges are available. Contact Honeywell Customer Service for more information.

MPR Series Sensor Mounted on a Breakout Board

Breakout boards, designed for use with the Honeywell SEK002 Sensor Evaluation Kit, are available with the sensor already mounted.

MPR Series with long port mounted on a breakout board.



MPR Series with short port mounted on a breakout board.



TABLE 8. ORDER GUIDE FOR MPR SERIES SENSOR ON BREAKOUT BOARD

Catalog Listing	Description
MPRLS0025PA00001AB	Breakout board with 0 psi to 25 psi absolute sensor, long port, with gel, I ² C = 0x18, transfer function A
MPRLS0015PA0000SAB	Breakout board with 0 psi to 15 psi absolute sensor, long port, with gel, SPI, transfer function A
MPRLS0300YG00001BB	Breakout board with 0 mmHg to 300 mmHg gage sensor, long port, with gel, I ² C = 0x18, transfer function B
MPRSS0001PG00001CB	Breakout board with 0 psi to 1 psi gage sensor, short port, with gel, I ² C = 0x18, transfer function C

MICROPRESSURE BOARD MOUNT PRESSURE SENSORS

MPR SERIES

TABLE 9. PRESSURE RANGE SPECIFICATIONS FOR 60 MBAR TO 2.5 BAR

Pressure Range (See Figure 4.)	Pressure Range		Unit	Over Pressure ¹	Burst Pressure ²	Total Error Band After Customer Auto-Zero ³ (%FSS)	Total Error Band, Typical (%FSS)	Transfer Function
	P _{MIN.}	P _{MAX.}						
Absolute								
0001BA	0	1	bar	4	8	±1.5 ⁴	±1.5	A, B
01.6BA	0	1.6	bar	4	8	±1.5 ⁴	±1.5	A, B
02.5BA	0	2.5	bar	4	8	±1.5 ⁴	±1.5	A, B
Gage								
0060MG	0	60	mbar	350	700	±1.25	±2.5	C
0100MG	0	100	mbar	350	700	±1.25	±2.5	C
0160MG	0	160	mbar	350	700	±1.25	±2.5	C
0250MG	0	250	mbar	350	700	±1.25	±2.5	C
0400MG	0	400	mbar	4000	8000	±2.0	±2.5	A, B
0600MG	0	600	mbar	4000	8000	±2.0	±2.5	A, B
0001BG	0	1	bar	4	8	±1.5	±2.5	A, B
01.6BG	0	1.6	bar	4	8	±1.5	±2.5	A, B
02.5BG	0	2.5	bar	4	8	±1.5	±2.5	A, B

¹ **Overpressure:** The maximum pressure which may safely be applied to the product for it to remain in specification once pressure is returned to the operating pressure range. Exposure to higher pressures may cause permanent damage to the product. Unless otherwise specified this applies to all available pressure ports at any temperature with the operating temperature range. The customer's pressure connection system (tubing or O-rings) must be specified to be equal to, or greater than, the rated overpressure limit. Due to the possibility of light sensitivity, opaque tubing is recommended.

² **Burst Pressure:** The maximum pressure that may be applied to any port of the product without causing escape of pressure media. Product should not be expected to function after exposure to any pressure beyond the burst pressure.

³ **Total Error Band after Customer Auto-Zero:** The maximum deviation from the ideal transfer function over the entire compensated pressure range for a minimum of 24 hours after an auto-zero operation. Includes all errors due to full scale span, pressure non-linearity, pressure hysteresis, and thermal effect on span. Low pressure MPR sensors may exhibit offset shifts after reflow solder. See Technical Note "Auto-Zero Calibration Technique for Pressure Sensors" (008326-1-EN) if this shift is significant in a particular application.

⁴ Because atmospheric pressure is continually changing, autozeroing an absolute pressure sensor requires a reference standard. If the actual absolute pressure is important in an application (such as for a barometer), an external precision reference is needed to set the offset to the correct current value of atmospheric pressure. In applications where the difference between multiple absolute sensors is important, any reference may be used (such as one of the other absolute pressure sensors in a system, or even an arbitrary pressure like 14.7 psia), as long as it is consistent and repeatable.

MICROPRESSURE BOARD MOUNT PRESSURE SENSORS

MPR SERIES

TABLE 10. PRESSURE RANGE SPECIFICATIONS FOR 6 KPA TO 250 KPA

Pressure Range (See Figure 4.)	Pressure Range		Unit	Over Pressure ¹	Burst Pressure ²	Total Error Band After Customer Auto-Zero ³ (%FSS)	Total Error Band, Typical (%FSS)	Transfer Function
	P _{MIN.}	P _{MAX.}						
Absolute								
0100KA	0	100	kPa	400	800	±1.5 ⁴	±1.5	A, B
0160KA	0	160	kPa	400	800	±1.5 ⁴	±1.5	A, B
0250KA	0	250	kPa	400	800	±1.5 ⁴	±1.5	A, B
Gage								
0006KG	0	6	kPa	35	70	±1.25	±2.5	C
0010KG	0	10	kPa	35	70	±1.25	±2.5	C
0016KG	0	16	kPa	35	70	±1.25	±2.5	C
0025KG	0	25	kPa	35	70	±1.25	±2.5	C
0040KG	0	40	kPa	400	800	±2.0	±2.5	A, B
0060KG	0	60	kPa	400	800	±2.0	±2.5	A, B
0100KG	0	100	kPa	400	800	±1.5	±2.5	A, B
0160KG	0	160	kPa	400	800	±1.5	±2.5	A, B
0250KG	0	250	kPa	400	800	±1.5	±2.5	A, B

¹ **Overpressure:** The maximum pressure which may safely be applied to the product for it to remain in specification once pressure is returned to the operating pressure range. Exposure to higher pressures may cause permanent damage to the product. Unless otherwise specified this applies to all available pressure ports at any temperature with the operating temperature range. The customer's pressure connection system (tubing or O-rings) must be specified to be equal to, or greater than, the rated overpressure limit. Due to the possibility of light sensitivity, opaque tubing is recommended.

² **Burst Pressure:** The maximum pressure that may be applied to any port of the product without causing escape of pressure media. Product should not be expected to function after exposure to any pressure beyond the burst pressure.

³ **Total Error Band after Customer Auto-Zero:** The maximum deviation from the ideal transfer function over the entire compensated pressure range for a minimum of 24 hours after an auto-zero operation. Includes all errors due to full scale span, pressure non-linearity, pressure hysteresis, and thermal effect on span. Low pressure MPR sensors may exhibit offset shifts after reflow solder. See Technical Note "Auto-Zero Calibration Technique for Pressure Sensors" (008326-1-EN) if this shift is significant in a particular application.

⁴ Because atmospheric pressure is continually changing, autozeroing an absolute pressure sensor requires a reference standard. If the actual absolute pressure is important in an application (such as for a barometer), an external precision reference is needed to set the offset to the correct current value of atmospheric pressure. In applications where the difference between multiple absolute sensors is important, any reference may be used (such as one of the other absolute pressure sensors in a system, or even an arbitrary pressure like 14.7 psia), as long as it is consistent and repeatable.

MICROPRESSURE BOARD MOUNT PRESSURE SENSORS

MPR SERIES

TABLE 11. PRESSURE RANGE SPECIFICATIONS FOR 1 PSI TO 30 PSI

Pressure Range (See Figure 4.)	Pressure Range		Unit	Over Pressure ¹	Burst Pressure ²	Total Error Band After Customer Auto-Zero ³ (%FSS)	Total Error Band, Typical (%FSS)	Transfer Function
	P _{MIN.}	P _{MAX.}						
Absolute								
0015PA	0	15	psi	60	120	±1.5 ⁴	±1.5	A, B
0025PA	0	25	psi	60	120	±1.5 ⁴	±1.5	A, B
0030PA	0	30	psi	60	120	±1.5 ⁴	±1.5	A, B
Gage								
0001PG	0	1	psi	5	10	±1.25	±2.5	C
0005PG	0	5	psi	60	120	±2.0	±2.5	A, B
0015PG	0	15	psi	60	120	±1.5	±2.5	A, B
0030PG	0	30	psi	60	120	±1.5	±2.5	A, B

¹**Overpressure:** The maximum pressure which may safely be applied to the product for it to remain in specification once pressure is returned to the operating pressure range. Exposure to higher pressures may cause permanent damage to the product. Unless otherwise specified this applies to all available pressure ports at any temperature with the operating temperature range. The customer's pressure connection system (tubing or O-rings) must be specified to be equal to, or greater than, the rated overpressure limit. Due to the possibility of light sensitivity, opaque tubing is recommended.

²**Burst Pressure:** The maximum pressure that may be applied to any port of the product without causing escape of pressure media. Product should not be expected to function after exposure to any pressure beyond the burst pressure.

³**Total Error Band after Customer Auto-Zero:** The maximum deviation from the ideal transfer function over the entire compensated pressure range for a minimum of 24 hours after an auto-zero operation. Includes all errors due to full scale span, pressure non-linearity, pressure hysteresis, and thermal effect on span. Low pressure MPR sensors may exhibit offset shifts after reflow solder. See Technical Note "Auto-Zero Calibration Technique for Pressure Sensors" (008326-1-EN) if this shift is significant in a particular application.

⁴Because atmospheric pressure is continually changing, autozeroing an absolute pressure sensor requires a reference standard. If the actual absolute pressure is important in an application (such as for a barometer), an external precision reference is needed to set the offset to the correct current value of atmospheric pressure. In applications where the difference between multiple absolute sensors is important, any reference may be used (such as one of the other absolute pressure sensors in a system, or even an arbitrary pressure like 14.7 psia), as long as it is consistent and repeatable.

TABLE 12. PRESSURE RANGE SPECIFICATIONS FOR 0 MMHG TO 300 MMHG

Pressure Range (See Figure 4.)	Pressure Range		Unit	Over Pressure ¹	Burst Pressure ²	Total Error Band After Customer Auto-Zero ³ (%FSS)	Total Error Band, Typical (%FSS)	Transfer Function
	P _{MIN.}	P _{MAX.}						
Gage								
0300YG	0	300	mmHg	3100	6200	±2.0	±2.5	B

¹**Overpressure:** The maximum pressure which may safely be applied to the product for it to remain in specification once pressure is returned to the operating pressure range. Exposure to higher pressures may cause permanent damage to the product. Unless otherwise specified this applies to all available pressure ports at any temperature with the operating temperature range. The customer's pressure connection system (tubing or O-rings) must be specified to be equal to, or greater than, the rated overpressure limit. Due to the possibility of light sensitivity, opaque tubing is recommended.

²**Burst Pressure:** The maximum pressure that may be applied to any port of the product without causing escape of pressure media. Product should not be expected to function after exposure to any pressure beyond the burst pressure.

³**Total Error Band after Customer Auto-Zero:** The maximum deviation from the ideal transfer function over the entire compensated pressure range for a minimum of 24 hours after an auto-zero operation. Includes all errors due to full scale span, pressure non-linearity, pressure hysteresis, and thermal effect on span. Low pressure MPR sensors may exhibit offset shifts after reflow solder. See Technical Note "Auto-Zero Calibration Technique for Pressure Sensors" (008326-1-EN) if this shift is significant in a particular application.

MICROPRESSURE BOARD MOUNT PRESSURE SENSORS MPR SERIES

1.0 GENERAL INFORMATION

Please see pages 19-22 for product dimensions, pinouts, tape and reel dimensions, Recommended Pick and Place Geometry, and recommended tubing.

2.0 PINOUT AND FUNCTIONALITY (SEE TABLE 13.)

TABLE 13. PINOUT AND FUNCTIONALITY

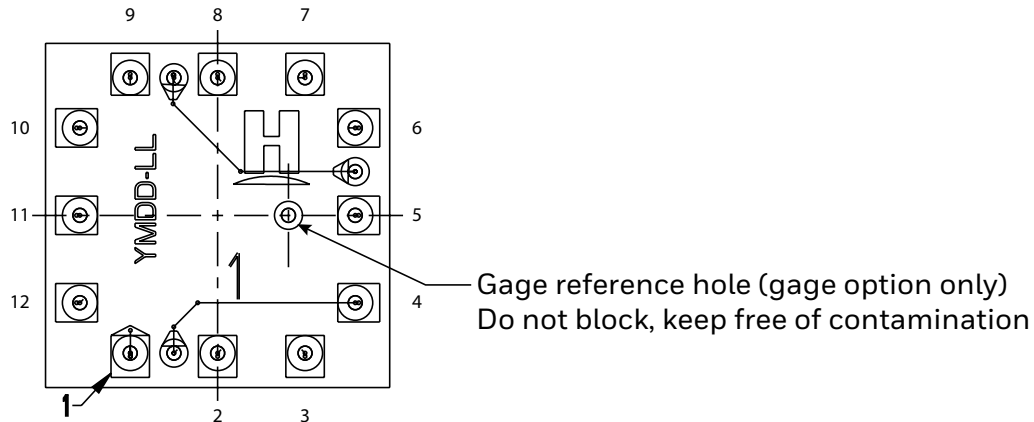

Pad Number	Name	Description
1	SS	Sensor Select: Chip select for SPI sensor
2	MOSI/SDA	Master Out Sensor In: Data in for SPI sensor; data in/out for I ² C sensor
3	SCLK/SCL	Clock input for SPI and I ² C sensor
4	VO+	V _{OUT+} pin in piezoresistive Wheatstone Bridge: Anti-aliasing filter can be connected between VO+ and VO-
5	NC	No connection
6	VO-	V _{OUT-} pin in piezoresistive Wheatstone Bridge: Anti-aliasing filter can be connected between VO- and VO+
7	MISO	Master In Sensor Out: Data output for SPI sensor
8	EOC	End-of-conversion indicator: This pin is set high when a measurement and calculation have been completed and the data is ready to be clocked out
9	RES	Reset: This pin can be connected and used to control safe resetting of the sensor. RES is active-low; a V _{DD} -V _{SS} -V _{DD} transition at the RES pin leads to a complete sensor reset
10	V _{SS}	Ground reference voltage signal
11	NC	No connection
12	V _{DD}	Positive supply voltage

3.0 START-UP TIMING

On power-up, the MPR Series sensor is able to receive the first command after 1 ms from when the V_{DD} supply is within operating specifications. The MPR Series sensor can begin the first measurement after 2.5 ms from when the V_{DD} supply is operational. Alternatively, instead of a power-on reset, a reset and new power-up sequence can be triggered by an IC-reset signal (high low) at the RES pin.

4.0 POWER SUPPLY REQUIREMENT

Verify that system power to the sensor meets the V_{DD} rising slope requirement (minimum V_{DD} rising slope is at least 10 V/ms). If not, use the RES pin to bring the sensor out of reset once the system power has stabilized.

MICROPRESSURE BOARD MOUNT PRESSURE SENSORS MPR SERIES

5.0 REFERENCE CIRCUIT DESIGN

5.1 I²C AND SPI CIRCUIT DIAGRAMS (SEE FIGURES 5 AND 6.)

FIGURE 5. I²C CIRCUIT DIAGRAM

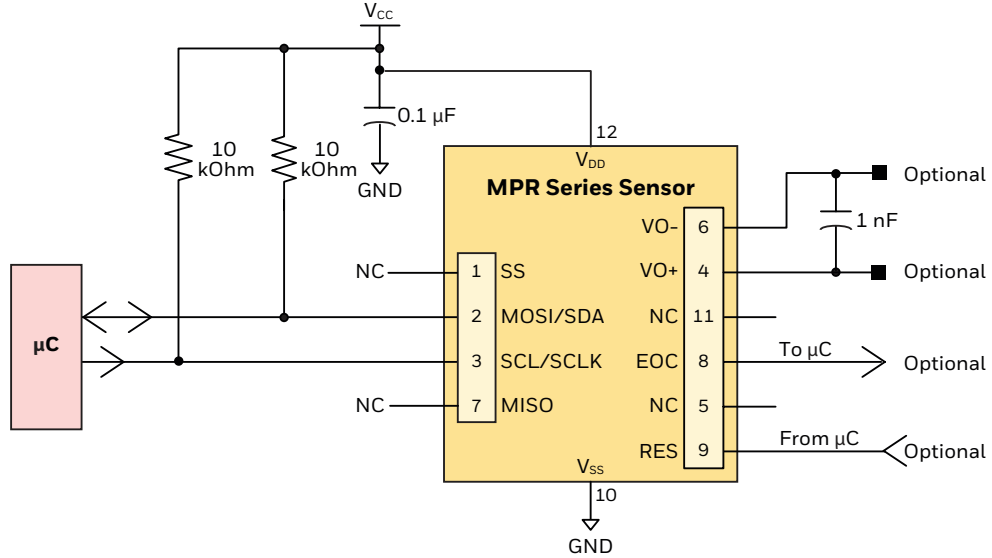
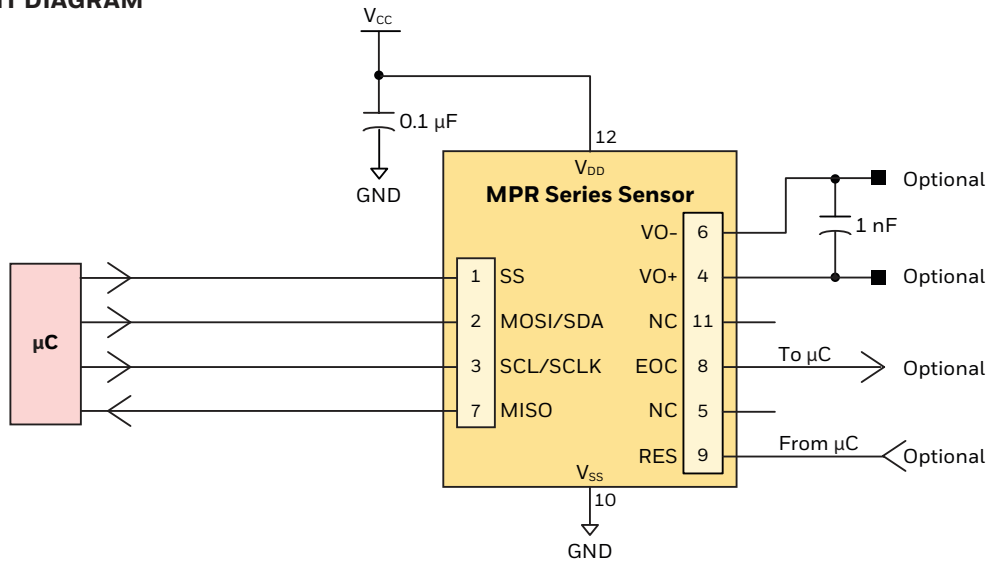

FIGURE 6. SPI CIRCUIT DIAGRAM



5.2 BYPASS CAPACITOR USE

NOTICE

Ensure bypass capacitors are integrated into the end user design to ensure output noise suppression.

MICROPRESSURE BOARD MOUNT PRESSURE SENSORS MPR SERIES

6.0 I²C COMMUNICATIONS

6.1 I²C BUS CONFIGURATION (SEE FIGURE 7.)

The I²C bus is a simple, serial 8-bit oriented computer bus for efficient I²C (Inter-IC) control. It provides good support for communication between different ICs across short circuit-board distances, such as interfacing microcontrollers with various low speed peripheral devices. For detailed specifications of the I²C protocol, see Rev. 6 (April 2014) of the I²C Bus Specification (source: NXP Semiconductor at <https://www.nxp.com/docs/en/user-guide/UM10204.pdf>).

Each device connected to the bus is software addressable by a unique address and a simple Master/Sensor relationship that exists at all times. The output stages of devices connected to the bus are designed around an open collector architecture. Because of this, pull-up resistors to +V_{DD} must be provided on the bus. Both SDA and SCL are bidirectional lines, and it is important to system performance to match the capacitive loads on both lines. In addition, in accordance with the I²C specification, the maximum allowable capacitance on either line is 400 pF to ensure reliable edge transitions at 400 kHz clock speeds.

When the bus is free, both lines are pulled up to +V_{DD}. Data on the I²C bus can be transferred at a rate up to 100 kbit/s in the standard-mode, or up to 400 kbit/s in the fast-mode.

FIGURE 7. I²C BUS CONFIGURATION

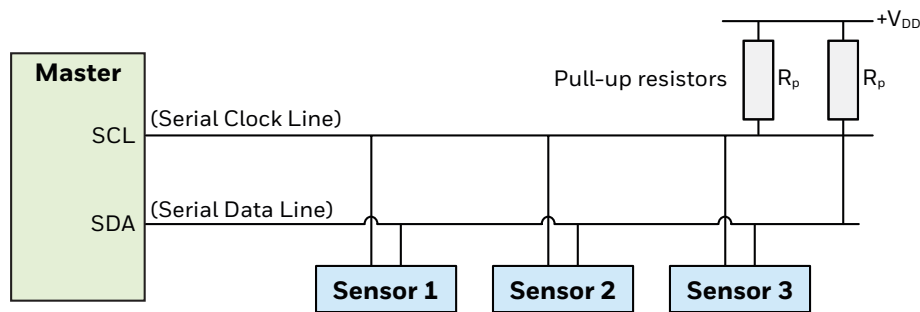

6.2 I²C DATA TRANSFER

The MPR Series I²C Sensors will only respond to requests from a Master device. Following the address and read bit from the Master, the MPR Series Sensors are designed to output up to 4 bytes of data. The first data byte is the Status Byte (8-bit) and the second to fourth bytes are the compensated pressure output (24-bit).

6.3 I²C SENSOR ADDRESS

Each MPR Series I²C Sensor is referenced on the bus by a 7-bit sensor address. The default address for the MPR Series is 24 (0x18). Other available standard addresses are: 08 (0x08), 40 (0x28), 56 (0x38), 72 (0x48), 88 (0x58), 104 (0x68), 120 (0x78). (Other custom values are available. Please contact Honeywell Customer Service with questions regarding custom Sensor addresses.)

6.4 I²C PRESSURE READING

To read out a compensated pressure reading, the Master generates a START condition and sends the Sensor address followed by a read bit (1). After the Sensor generates an acknowledge, it will transmit up to 4 bytes of data. The first data byte is the Status Byte (8-bit) and the second to fourth bytes are the compensated pressure output (24-bit). The Master must acknowledge the receipt of each byte, and can terminate the communication by sending a Not Acknowledge (NACK) bit followed by a Stop bit after receiving the required bytes of data.

MICROPRESSURE BOARD MOUNT PRESSURE SENSORS MPR SERIES

6.5 I²C STATUS BYTE (SEE TABLE 14.)

TABLE 14. I ² C STATUS BYTE EXPLANATION		
Bit (Meaning)	Status	Comment
7	always 0	—
6 (Power indication)	1 = device is powered 0 = device is not powered	Needed for the SPI Mode where the Master reads all zeroes if the device is not powered or in power-on reset (POR).
5 (Busy flag)	1 = device is busy	Indicates that the data for the last command is not yet available. No new commands are processed if the device is busy.
4	always 0	—
3	always 0	—
2 (Memory integrity/error flag)	0 = integrity test passed 1 = integrity test failed	Indicates whether the checksum-based integrity check passed or failed; the memory error status bit is calculated only during the power-up sequence.
1	always 0	—
0 (Math saturation)	1 = internal math saturation has occurred	—

6.6 I²C COMMUNICATIONS

6.6.1 I²C Output Measurement Command

To communicate with the MPR Series I²C output sensor using an Output Measurement Command of “0xAA”, followed by “0x00” “0x00”, follow the steps shown in Table 15. This command will cause the device to exit Standby Mode and enter Operating Mode. At the conclusion of the measurement cycle, the device will automatically re-enter Standby Mode.

TABLE 15. I ² C OUTPUT MEASUREMENT COMMAND		
Step	Action	Notes
1	<p>Write bit</p>	<ul style="list-style-type: none"> Master to Sensor Sensor to Master
2	<p>Option 1: Wait until the busy flag in the Status Byte clears.</p> <p>Option 2: Wait for at least 5 ms for the data conversion to occur.</p> <p>Option 3: Wait for the EOC indicator.</p> <p>Read bit</p>	<ul style="list-style-type: none"> S Start condition P Stop condition A Acknowledge N Not acknowledge
3	<p>To read the 24-bit pressure output along with the 8-bit Status Byte:</p> <p>Read bit</p>	

MICROPRESSURE BOARD MOUNT PRESSURE SENSORS MPR SERIES

6.6.2 I²C Sensor Address of 0x18

To communicate with the MPR Series I²C output sensor with an I²C Sensor Address of 0x18 (hex), follow the steps shown in Table 16.

TABLE 16. I²C SENSOR ADDRESS OF 0X18 COMMUNICATIONS

Step	Action	Notes
1	<p>Write bit</p>	<ul style="list-style-type: none"> Master to Sensor Sensor to Master Start condition Stop condition Acknowledge Not acknowledge
2	<p>Option 1: Wait until the busy flag in the Status Byte clears.</p> <p>Option 2: Wait for at least 5 ms for the data conversion to occur.</p> <p>Option 3: Wait for the EOC indicator.</p> <p>Read bit</p>	
3	<p>To read the 24-bit pressure output along with the 8-bit Status Byte:</p> <p>Read bit</p>	

6.7 I²C TIMING AND LEVEL PARAMETERS (SEE TABLE 17.)

TABLE 17. I²C BUS TIMING DIAGRAM AND PARAMETERS

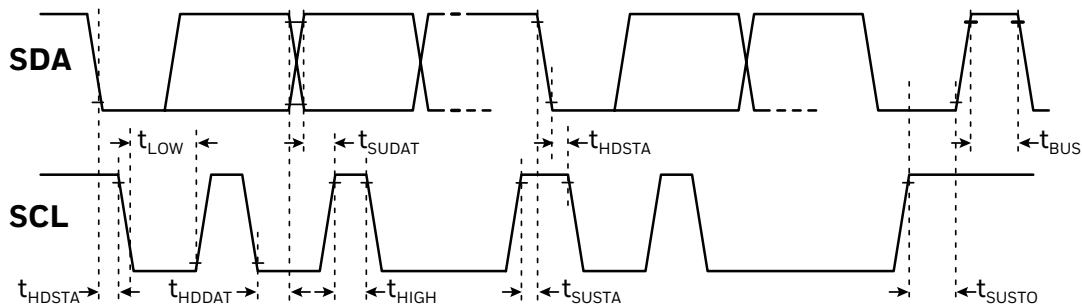

Characteristic	Abbreviation	Min.	Typ.	Max.	Unit
SCLK clock frequency	f_{SCL}	100	—	400	kHz
Start condition hold time relative to SCL edge	t_{HDSTA}	0.1	—	—	μ s
Minimum SCLK clock low width ¹	t_{LOW}	0.6	—	—	μ s
Minimum SCLK clock high width ¹	t_{HIGH}	0.6	—	—	μ s
Start condition setup time relative to SCL edge	t_{SUSTA}	0.1	—	—	μ s
Data hold time on SDA relative to SCL edge	t_{HDDAT}	0	—	—	μ s
Data setup time on SDA relative to SCL edge	t_{SUDAT}	0.1	—	—	μ s
Stop condition setup time on SCL	t_{SUSTO}	0.1	—	—	μ s
Bus free time between stop condition and start condition	t_{BUS}	2	—	—	μ s
Output level low	Out_{low}	—	0	0.2	V_{DD}
Output level high	Out_{high}	0.8	1	—	V_{DD}
Pull-up resistance on SDA and SCL	R_p	1	—	50	kOhm

¹Combined low and high widths must equal or exceed minimum SCLK period.

MICROPRESSURE BOARD MOUNT PRESSURE SENSORS MPR SERIES

6.8 REFERENCE CODE (ARDUINO/GENUINO UNO) FOR I²C INTERFACE

See also Section 8.0 for details and examples of MPR Series Pressure and Temperature output calculations.

```
#include<Arduino.h>
#include<Wire.h>

uint8_t id = 0x28; // i2c address
uint8_t data[7]; // holds output data
uint8_t cmd[3] = {0xAA, 0x00, 0x00}; // command to be sent
double press_counts = 0; // digital pressure reading [counts]
double temp_counts = 0; // digital temperature reading [counts]
double pressure = 0; // pressure reading [bar, psi, kPa, etc.]
double temperature = 0; // temperature reading in deg C
double outputmax = 15099494; // output at maximum pressure [counts]
double outputmin = 1677722; // output at minimum pressure [counts]
double pmax = 1; // maximum value of pressure range [bar, psi, kPa, etc.]
double pmin = 0; // minimum value of pressure range [bar, psi, kPa, etc.]
double percentage = 0; // holds percentage of full scale data
char printBuffer[200], cBuff[20], percBuff[20], pBuff[20], tBuff[20];
void setup() {
  Serial.begin(9600);
  while (!Serial) {
    delay(10);
  }
  Wire.begin();
  sprintf(printBuffer, "\nStatus Register, 24 - bit Sensor data, Digital Pressure Counts,\
  Percentage of full scale pressure, Pressure Output, Temperature\n");
  Serial.println(printBuffer);
}
void loop() {
  Wire.beginTransmission(id);
  int stat = Wire.write (cmd, 3); // write command to the sensor
  stat |= Wire.endTransmission();
  delay(10);
  Wire.requestFrom(id, 7); // read back Sensor data 7 bytes
  int i = 0;
  for (i = 0; i < 7; i++) {
    data [i] = Wire.read();
  }
  press_counts = data[3] + data[2] * 256 + data[1] * 65536; // calculate digital pressure counts
  temp_counts = data[6] + data[5] * 256 + data[4] * 65536; // calculate digital temperature counts
  temperature = (temp_counts * 200 / 16777215) - 50; // calculate temperature in deg c
  percentage = (press_counts / 16777215) * 100; // calculate pressure as percentage of full scale
  //calculation of pressure value according to equation 2 of datasheet
  pressure = ((press_counts - outputmin) * (pmax - pmin)) / (outputmax - outputmin) + pmin;
  dtostrf(press_counts, 4, 1, cBuff);
  dtostrf(percentage, 4, 3, percBuff);
  dtostrf(pressure, 4, 3, pBuff);
  dtostrf(temperature, 4, 3, tBuff);
  /*
  The below code prints the raw data as well as the processed data
  Data format : Status Register, 24-bit Sensor Data, Digital Counts, percentage of full scale
  pressure,
  pressure output, temperature
  */
  sprintf(printBuffer, " %x\t% 2x % 2x % 2x\t% s\t% s\t% s\t% s \n", data[0], data[1], data[2],
    data[3],
    cBuff, percBuff, pBuff, tBuff);
  Serial.print(printBuffer);
  delay(10);
}
```



MICROPRESSURE BOARD MOUNT PRESSURE SENSORS MPR SERIES

7.0 SPI COMMUNICATIONS

7.1 SPI DEFINITION

The Serial Peripheral Interface (SPI) is a simple bus system for synchronous serial communication between one Master and one or more Sensors. It operates either in full-duplex or half-duplex mode, allowing communication to occur in either both directions simultaneously, or in one direction only. The Master device initiates an information transfer on the bus and generates clock and control signals. Sensors are controlled by the Master through individual Sensor Select (SS) lines and are active only when selected. The MPR Series SPI sensors operate in full-duplex mode only, with data transfer from the Sensor to the Master. This data transmission uses four, unidirectional bus lines. The Master controls SCLK, MOSI and SS; the Sensor controls MISO. (See Figure 8.)

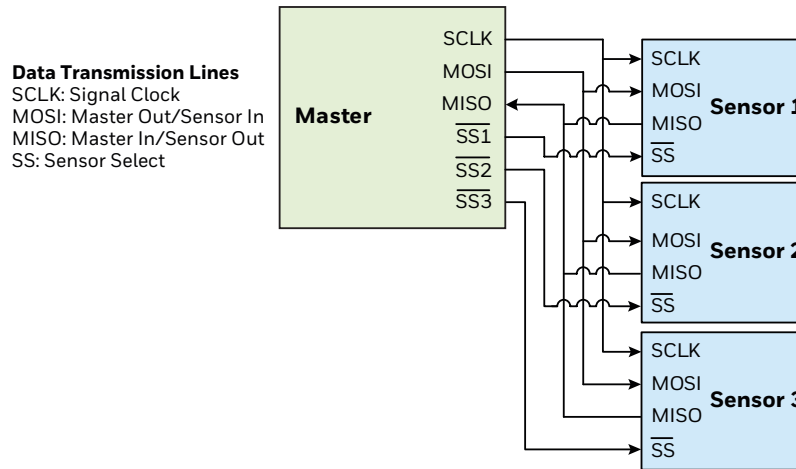
FIGURE 8. SPI BUS CONFIGURATION



7.2 SPI DATA TRANSFER

Start communication with the MPR Series SPI sensors by de-asserting the Sensor Select (SS) line. At this point, the sensor is no longer idle, and will begin sending data once a clock is received. MPR Series SPI sensors are configured for SPI operation in mode 0 (clock polarity is 0 and clock phase is 0). (See Figure 9.)

FIGURE 9. EXAMPLE OF 1 BYTE SPI DATA TRANSFER

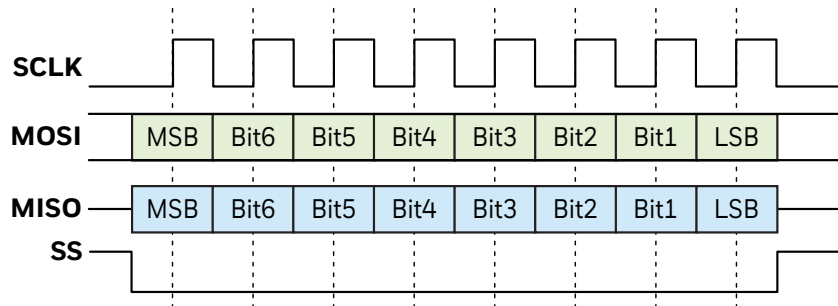

Once the clocking begins, the MPR Series SPI sensor is designed to output up to 4 bytes of data. The first data byte is the Status Byte (8-bit) and the second to fourth bytes are the compensated pressure output (24-bit).

7.3 SPI PRESSURE READING

To read out a compensated pressure reading, the Master generates the necessary clock signal after activating the sensor with the Sensor Select (SS) line. The sensor will transmit up to 4 bytes of data. The first data byte is the Status Byte (8-bit) and the second to fourth bytes are the compensated pressure output (24-bit). The Master can terminate the communication by stopping the clock and deactivating the SS line.

7.4 SPI STATUS BYTE

The SPI status byte contains the bits shown in Table 18.

MICROPRESSURE BOARD MOUNT PRESSURE SENSORS MPR SERIES

7.5 SPI COMMUNICATION

To communicate with the MPR Series SPI output sensor using an Output Measurement Command of “0xAA”, followed by “0x00” “0x00”, follow the steps shown in Table 18. This command will cause the device to exit Standby Mode and enter Operating Mode. At the conclusion of the measurement cycle, the device will automatically re-enter Standby Mode.

TABLE 18. SPI OUTPUT MEASUREMENT COMMAND

Step	Action				Notes	
1	The data on MISO depend on the preceding command. Discard the data on the MISO line.					
	MOSI	0xAA	0x00	0x00	<div style="display: flex; flex-direction: column; align-items: center;"> <div style="width: 15px; height: 15px; background-color: #d9ead3; border: 1px solid #ccc; margin-bottom: 5px;"></div> Master to Sensor <div style="width: 15px; height: 15px; background-color: #d9ead3; border: 1px solid #ccc; margin-bottom: 5px; margin-left: 20px;"></div> <div style="width: 15px; height: 15px; background-color: #d9ead3; border: 1px solid #ccc; margin-bottom: 5px; margin-left: 40px;"></div> <div style="width: 15px; height: 15px; background-color: #f4cccc; border: 1px solid #ccc; margin-bottom: 5px; margin-left: 20px;"></div> Sensor to Master <div style="width: 15px; height: 15px; background-color: #f4cccc; border: 1px solid #ccc; margin-bottom: 5px; margin-left: 40px;"></div> </div>	
		Command other than NOP	CmdData <15:8>	CmdData <7:0>		
MISO	Status	Data	Data			
2	Option 1: Wait until the busy flag in the Status Byte clears. Option 2: Wait for at least 5 ms for the data conversion to occur. Option 3: Wait for the EOC indicator.					
	MOSI	0xFO				<ul style="list-style-type: none"> NOP Command is “0xFO”.
		Command = NOP				
MISO	Status					
3	To read the 24-bit pressure output along with the 8-bit Status Byte:					
	MOSI	0xFO	0x00	0x00	0x00	
		Command = NOP	00Hex	00Hex	00Hex	
MISO	Status	SensorDat <24:16>	SensorDat <15:8>	SensorDat <7:0>		

7.6 SPI TIMING AND LEVEL PARAMETERS (SEE TABLE 19.)

TABLE 19. SPI BUS TIMING DIAGRAM AND PARAMETERS

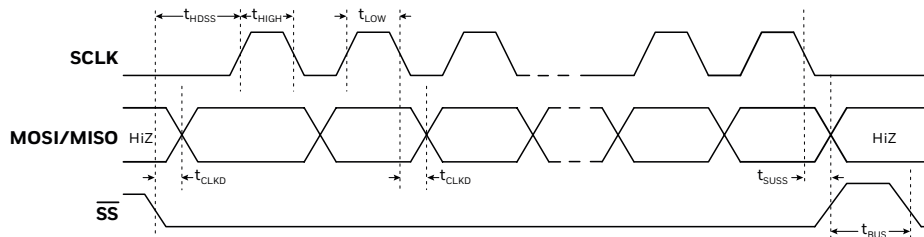

Characteristic	Abbreviation	Min.	Typ.	Max.	Unit
SCLK clock frequency	f_{SCL}	50	—	800	kHz
SS drop to first clock edge	t_{HDSS}	2.5	—	—	μ S
Minimum SCLK clock low width ¹	t_{LOW}	0.6	—	—	μ S
Minimum SCLK clock high width ¹	t_{HIGH}	0.6	—	—	μ S
Clock edge to data transition	t_{CLKD}	0	—	—	μ S
Rise of SS relative to last clock edge	t_{SUSS}	0.1	—	—	μ S
Bus free time between rise and fall of SS	t_{BUS}	2	—	—	μ S
Output level low	Out_{low}	—	0	0.2	V_{DD}
Output level high	Out_{high}	0.8	1	—	V_{DD}

¹Combined low and high widths must equal or exceed minimum SCLK period.

MICROPRESSURE BOARD MOUNT PRESSURE SENSORS MPR SERIES

7.7 REFERENCE CODE (ARDUINO/GENUINO UNO) FOR SPI INTERFACE

See also Section 8.0 for details and examples of MPR Series Pressure and Temperature output calculations.

```
#include<Arduino.h>
#include<SPI.h>

double press_counts = 0; // digital pressure reading [counts]
double temp_counts = 0; // digital temperature reading [counts]
double pressure = 0; // pressure reading [bar, psi, kPa, etc.]
double temperature = 0; // temperature reading in deg C
double outputmax = 15099494; // output at maximum pressure [counts]
double outputmin = 1677722; // output at minimum pressure [counts]
double pmax = 1; // maximum value of pressure range [bar, psi, kPa, etc.]
double pmin = 0; // minimum value of pressure range [bar, psi, kPa, etc.]
double percentage = 0; // holds percentage of full scale data
char printBuffer[200], cBuff[20], percBuff[20], pBuff[20], tBuff[20];
void setup() {
  Serial.begin(9600);
  while (!Serial) {
    delay(10);
  }
  sprintf(printBuffer, "\nStatus Register, 24-bit Sensor data, Digital Pressure Counts,\
Percentage of full scale pressure,Pressure Output, Temperature\n");
  Serial.println(printBuffer);
  SPI.begin();
  pinMode(10, OUTPUT); // pin 10 as SS
  digitalWrite(10, HIGH); // set SS High
}
void loop() {
  delay(1);
  while (1) {
    uint8_t data[7] = {0xFA, 0x00, 0x00, 0x00, 0x00, 0x00, 0x00}; // holds output data
    uint8_t cmd[3] = {0xAA, 0x00, 0x00}; // command to be sent
    SPI.beginTransaction(SPISettings(200000, MSBFIRST, SPI_MODE0)); //SPI at 200kHz
    digitalWrite(10, LOW); // set SS Low
    SPI.transfer(cmd, 3); // send Read Command
    digitalWrite(10, HIGH); // set SS High
    delay(10); // wait for conversion
    digitalWrite(10, LOW);
    SPI.transfer(data, 7);
    digitalWrite(10, HIGH);
    SPI.endTransaction();
    press_counts = data[3] + data[2] * 256 + data[1] * 65536; // calculate digital pressure counts
    temp_counts = data[6] + data[5] * 256 + data[4] * 65536; // calculate digital temperature counts
    temperature = (temp_counts * 200 / 16777215) - 50; // calculate temperature in deg c
    percentage = (press_counts / 16777215) * 100; // calculate pressure as percentage of full scale
    //calculation of pressure value according to equation 2 of datasheet
    pressure = ((press_counts - outputmin) * (pmax - pmin)) / (outputmax - outputmin) + pmin;
    dtostrf(press_counts, 4, 1, cBuff);
    dtostrf(percentage, 4, 3, percBuff);
    dtostrf(pressure, 4, 3, pBuff);
    dtostrf(temperature, 4, 3, tBuff);
    /*
     The below code prints the raw data as well as the processed data
     Data format : Status Register, 24-bit Sensor Data, Digital Counts, percentage of full scale
     pressure, pressure output,
     temperature
    */
    sprintf(printBuffer, "%x\t%2x %2x %2x\t%s\t%s\t%s\t%s \n", data[0], data[1], data[2], data[3],
      cBuff, percBuff, pBuff, tBuff);
    Serial.print(printBuffer);
    delay(10);
  }
}
```

MICROPRESSURE BOARD MOUNT PRESSURE SENSORS MPR SERIES

8.0 MPR SERIES SENSOR OUTPUT PRESSURE CALCULATION

The MPR Series sensor output can be expressed by the transfer function of the device as shown in Equation 1:

Equation 1: Pressure Sensor Transfer Function

$$\text{Output} = \frac{\text{Output}_{\text{max.}} - \text{Output}_{\text{min.}}}{P_{\text{max.}} - P_{\text{min.}}} * (\text{Pressure} - P_{\text{min.}}) + \text{Output}_{\text{min.}}$$

Rearranging this equation to solve for Pressure, we get Equation 2:

Equation 2: Pressure Output Function

$$\text{Pressure} = \frac{(\text{Output} - \text{Output}_{\text{min.}}) * (P_{\text{max.}} - P_{\text{min.}})}{\text{Output}_{\text{max.}} - \text{Output}_{\text{min.}}} + P_{\text{min.}}$$

Where:

Output_{max.} = output at maximum pressure [counts]

Output_{min.} = output at minimum pressure [counts]

P_{max.} = maximum value of pressure range [bar, psi, kPa, etc.]

P_{min.} = minimum value of pressure range [bar, psi, kPa, etc.]

Pressure = pressure reading [bar, psi, kPa, etc.]

Output = digital pressure reading [counts]

Example: Calculate the pressure for a -1 psi to 1 psi gage sensor with a 10% to 90% calibration, and a pressure output of 14260634 (decimal) counts:

Output_{max.} = 15099494 counts (90% of 2²⁴ counts or 0xE66666)

Output_{min.} = 1677722 counts (10% of 2²⁴ counts or 0x19999A)

P_{max.} = 1 psi

P_{min.} = -1 psi

Pressure = pressure in psi

Output = 14260634 counts

$$\text{Pressure} = \left[\frac{(14260634 - 1677722) * (1 - (-1))}{15099494 - 1677722} \right] + (-1)$$

$$\text{Pressure} = \frac{25165824}{13421772} + (-1)$$

$$\text{Pressure} = 0.875 \text{ psi}$$

MICROPRESSURE BOARD MOUNT PRESSURE SENSORS MPR SERIES

FIGURE 10. LONG PORT AND RECOMMENDED PCB PAD LAYOUT DIMENSIONS (FOR REFERENCE ONLY: MM [IN.]

Sensor

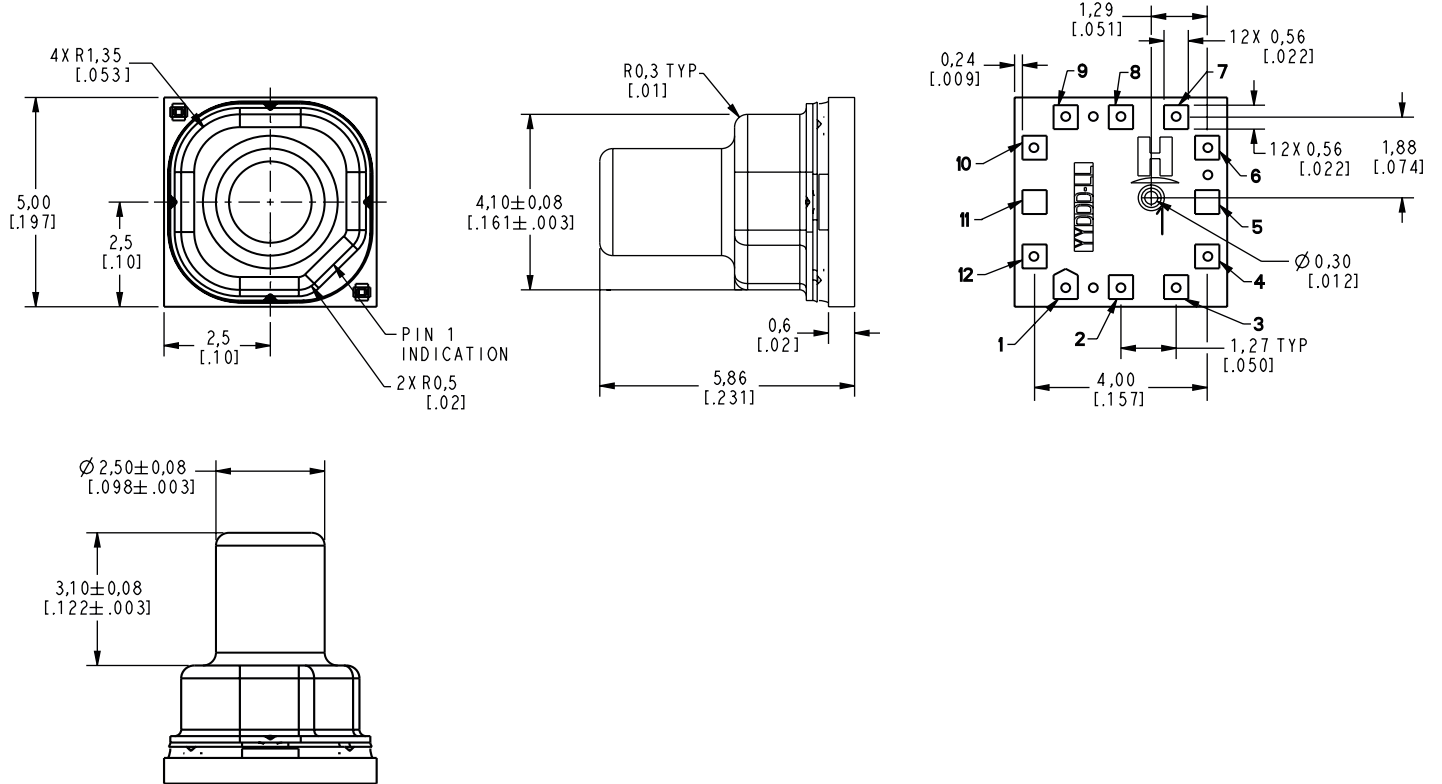

Recommended PCB pad layout

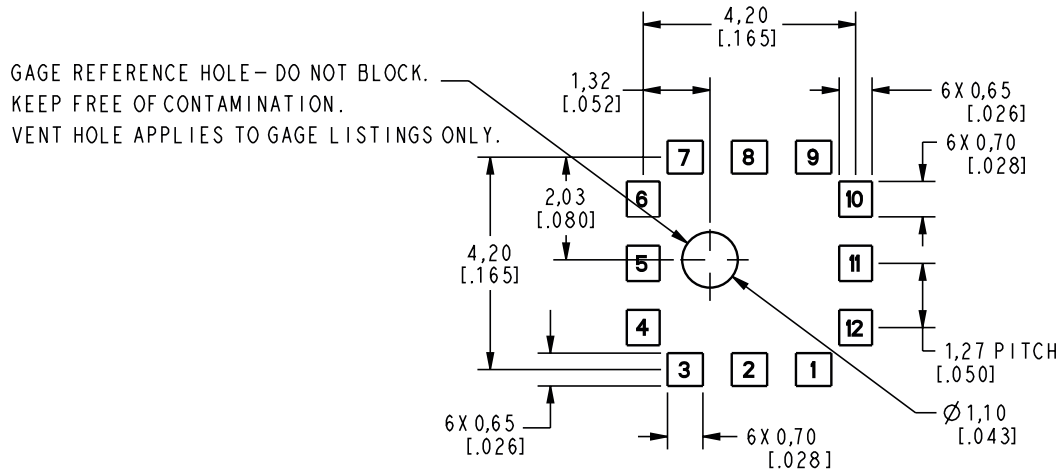

MICROPRESSURE BOARD MOUNT PRESSURE SENSORS MPR SERIES

FIGURE 11. SHORT PORT AND RECOMMENDED PCB PAD LAYOUT DIMENSIONS (FOR REFERENCE ONLY: MM [IN.]

Sensor

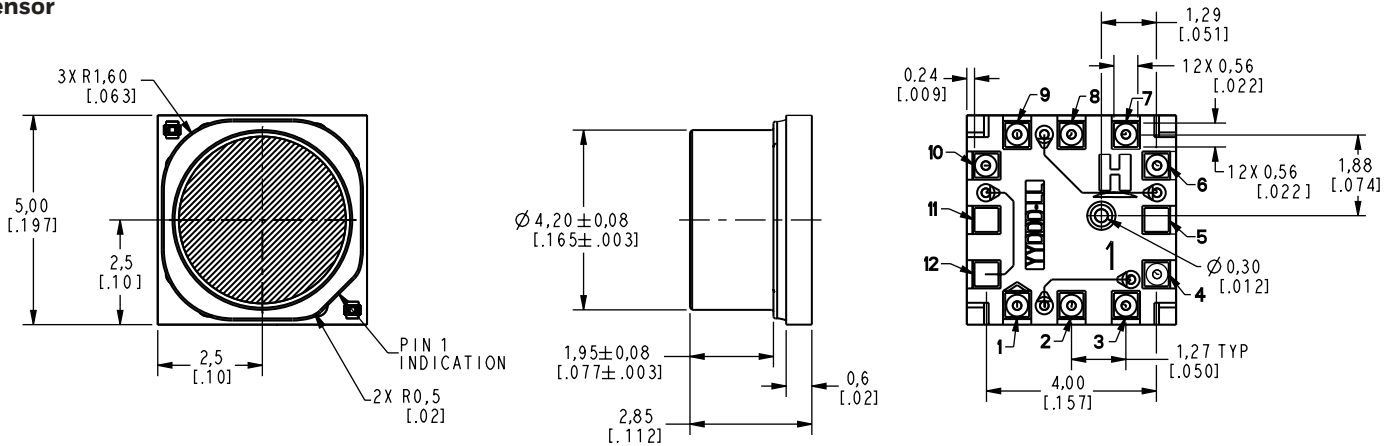

Reflowable protective silicone cap

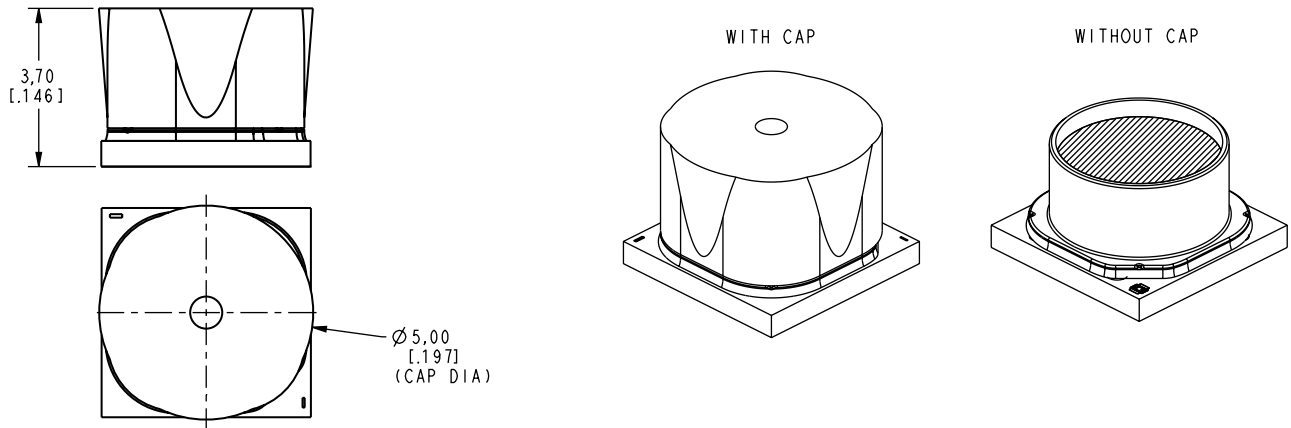

Recommended PCB pad layout

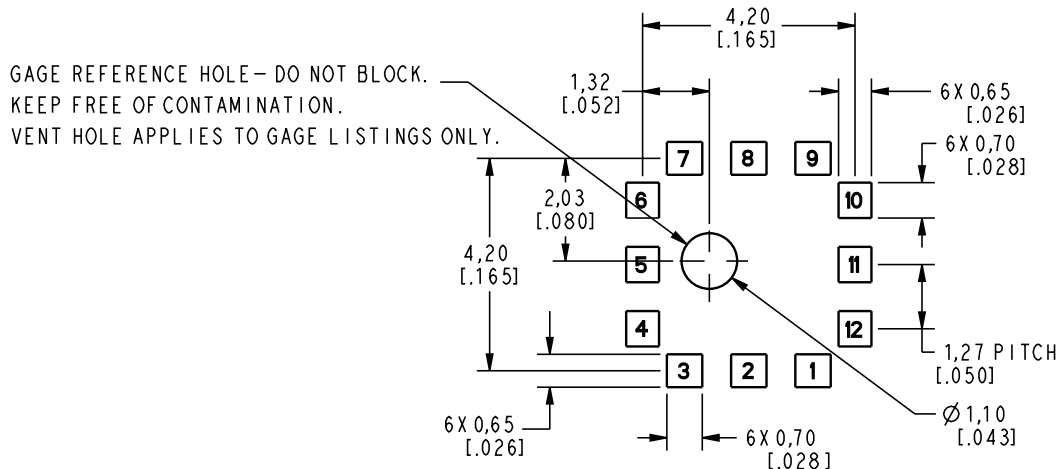

MICROPRESSURE BOARD MOUNT PRESSURE SENSORS MPR SERIES

FIGURE 12. TAPE AND REEL DIMENSIONS (FOR REFERENCE ONLY: MM.)

Long Port Tape

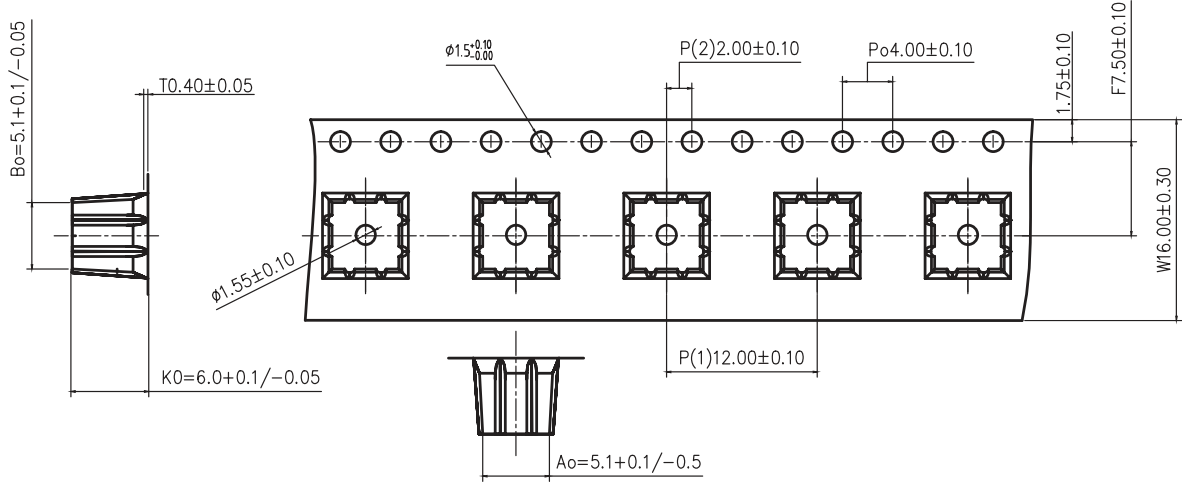

Short Port Tape

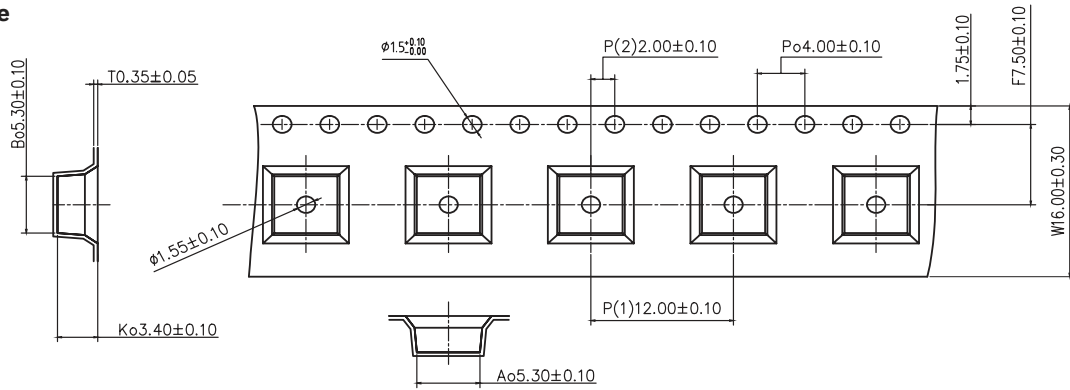

Reel

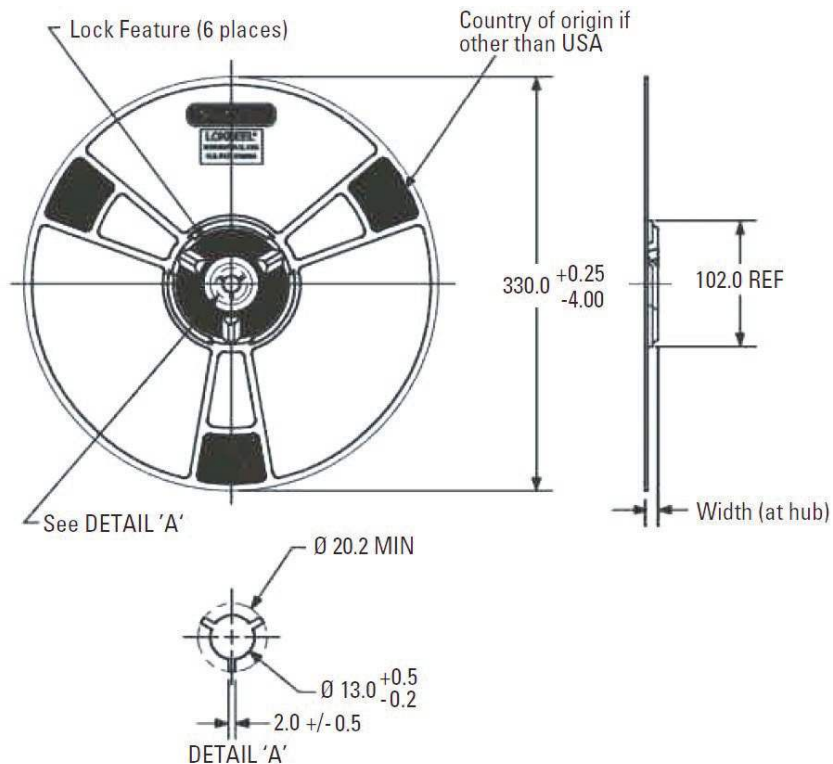

MICROPRESSURE BOARD MOUNT PRESSURE SENSORS MPR SERIES

REFLOWABLE PROTECTIVE SILICONE CAP

Every short port MPR Series sensor is shipped with a reflowable protective silicone cap intended to protect the sensor's protective gel throughout the assembly process (see Figure 10). This cap can withstand lead-free, reflow temperatures and is intended to be removed after the end-user has completed assembly of the MPR sensor to the mating assembly.

REFLOWABLE PROTECTIVE SILICONE CAP REMOVAL

Removal of the cap may easily be done manually using ESD-safe tweezers; however, if possible, and to eliminate possible sensor protective gel damage, the cap removal process should be done in a semi-automated or automated manner. If the cap must be removed manually, follow this removal process:

- Using ESD-safe tweezers, grasp the silicone cap midway up the straight port and lift the cap up vertically until it is no longer supported by the sensor housing.
- At this point, stop the vertical movement and relieve the grasp of the tweezers.
- Regrasp the cap in the unsupported area and continue the vertical movement until the cap is free and clear of the sensor's protective gel.
- Ensure that the sensor's protective gel is not damaged during the cap removal process.

RECOMMENDED TUBING

See Table 20 for recommended tubing information.

RECOMMENDED O-RINGS

For O-Ring location, size and recommended part numbers, see the following:

- Short port sensor: Figure 13 and Table 21.
- Long port sensor: Figure 14 and Table 22.

TABLE 20. RECOMMENDED TUBING

Manufacturer	Type	Part Number	ID (in)	OD (in)	Pressure at 25°C (psi)
Frelin-Wade	Fre-Thane® (polyurethane)	1A-156-11	0.093	0.156	210
Frelin-Wade	nylon	1A-200-01	0.093	0.125	270
NewAge Industries	PVC	1100225	0.094	0.156	42
NewAge Industries	silicone	2800315	0.094	0.156	20

MICROPRESSURE BOARD MOUNT PRESSURE SENSORS MPR SERIES

FIGURE 13. RECOMMENDED MANIFOLD DESIGN FOR SHORT PORT SENSOR WITH O-RING

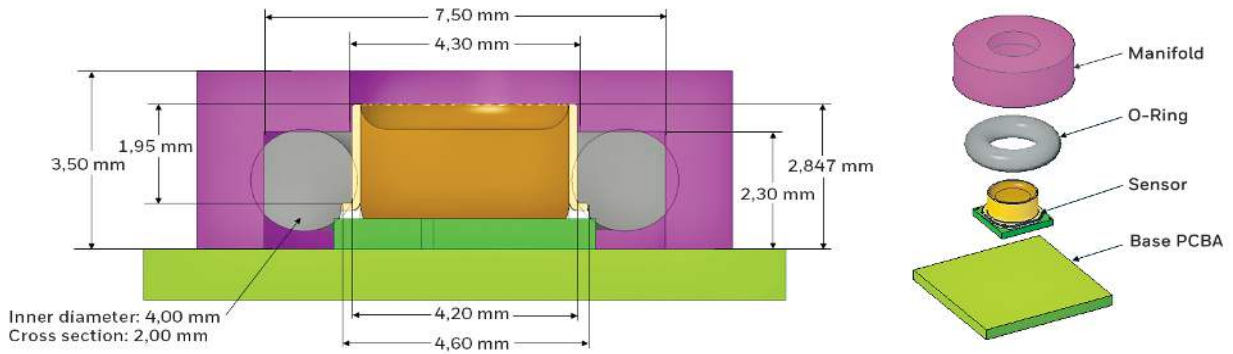

TABLE 21. RECOMMENDED O-RINGS FOR SHORT PORT SENSOR

ID (mm)	Cross Section (Width) (mm)	Supplier	Part Number	Material	Hardness
4.00	2.00	McMaster	9262K163	Buna-N	Durometer 70A
4.00	2.00	McMaster	1174N421	Buna-N	Durometer 50A
4.00	2.00	McMaster	1185N82	Viton® Fluoroelastomer	Durometer 75A
4.00	2.00	McMaster	9263K163	Viton® Fluoroelastomer	Durometer 75A
4.00	2.00	McMaster	5233T47	silicone	Durometer 70A
4.00	2.00	McMaster	1295N222	Viton® Fluoroelastomer	Durometer 75A
4.00	2.00	McMaster	1278N15	Kalrez 4079	Durometer 75A

FIGURE 14. RECOMMENDED MANIFOLD DESIGN FOR LONG PORT SENSOR WITH O-RING

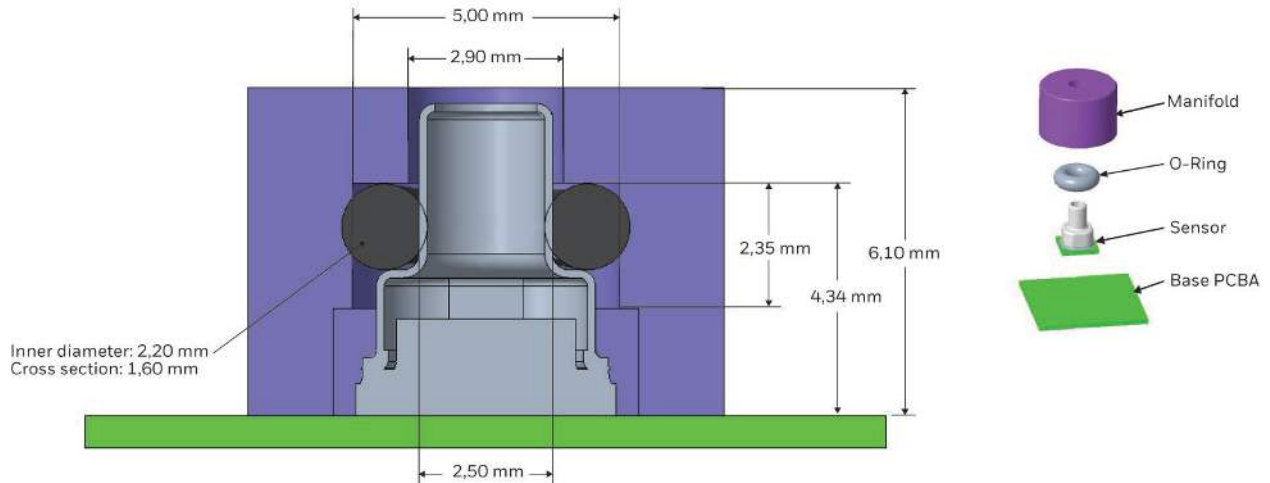

TABLE 22. RECOMMENDED O-RINGS FOR LONG PORT SENSOR

ID (mm)	Cross Section (Width) (mm)	Supplier	Part Number	Material	Hardness
2.20	1.60	McMaster	9262K131	Buna-N	Durometer 70A
2.20	1.60	McMaster	9263K131	Viton® Fluoroelastomer	Durometer 75A
2.20	1.60	McMaster	5233T142	silicone	Durometer 70A

WARRANTY/REMEDY

Honeywell warrants goods of its manufacture as being free of defective materials and faulty workmanship during the applicable warranty period. Honeywell's standard product warranty applies unless agreed to otherwise by Honeywell in writing; please refer to your order acknowledgment or consult your local sales office for specific warranty details. If warranted goods are returned to Honeywell during the period of coverage, Honeywell will repair or replace, at its option, without charge those items that Honeywell, in its sole discretion, finds defective.

The foregoing is buyer's sole remedy and is in lieu of all other warranties, expressed or implied, including those of merchantability and fitness for a particular purpose. In no event shall Honeywell be liable for consequential, special, or indirect damages.

While Honeywell may provide application assistance personally, through our literature and the Honeywell web site, it is buyer's sole responsibility to determine the suitability of the product in the application.

Specifications may change without notice. The information we supply is believed to be accurate and reliable as of this writing. However, Honeywell assumes no responsibility for its use.

FOR MORE INFORMATION

Honeywell Advanced Sensing Technologies services its customers through a worldwide network of sales offices and distributors. For application assistance, current specifications, pricing or the nearest Authorized Distributor, visit [our website](#) or call:

USA/Canada	+1 302 613 4491
Latin America	+1 305 805 8188
Europe	+44 1344 238258
Japan	+81 (0) 3-6730-7152
Singapore	+65 6355 2828
Greater China	+86 4006396841

Honeywell Advanced Sensing Technologies

830 East Arapaho Road
Richardson, TX 75081
sps.honeywell.com/ast

Fre-Thane® is a registered trademark of Freelin-Wade Co.
Viton® is a registered trademark The Chemours Company.

32332628-K-EN | K | 05/22
©2022 Honeywell International Inc. All rights reserved.

WARNING PERSONAL INJURY

DO NOT USE these products as safety or emergency stop devices or in any other application where failure of the product could result in personal injury.

Failure to comply with these instructions could result in death or serious injury.

WARNING MISUSE OF DOCUMENTATION

- The information presented in this product sheet is for reference only. Do not use this document as a product installation guide.
- Complete installation, operation, and maintenance information is provided in the instructions supplied with each product.

Failure to comply with these instructions could result in death or serious injury.

Honeywell