



380kHz, 2A Asynchronous DC-DC Buck Converter

AP3201A

General Description

The AP3201A is a 380kHz fixed frequency, current mode, PWM buck (step-down) DC-DC converter, capable of driving a 2A load with high efficiency, excellent line and load regulation. The device integrates N-channel power MOSFET switch with low on-resistance. Current mode control provides fast transient response and cycle-by-cycle current limit.

A standard series of inductors are available from several different manufacturers optimized for use with the AP3201A. This feature greatly simplifies the design of switch-mode power supplies.

This IC is available in HMSOP-10 package.

Features

- Input Voltage Range: 4.75V to 18V
- Fixed 380kHz Frequency
- High Efficiency: up to 93%
- Output Current: 2A
- Current Mode Control
- Built-in Over Current Protection
- Built-in Thermal Shutdown Function
- Built-in UVLO Function
- Built-in Over Voltage Protection
- Programmable Soft-start

Applications

- LCD TV
- Set Top Box
- Portable DVD
- Digital Photo Frame



Figure 1. Package Type of AP3201A

380kHz, 2A Asynchronous DC-DC Buck Converter
AP3201A
Pin Configuration

Figure 2. Pin Configuration of AP3201A (Top View)

Pin Description

Pin Number	Pin Name	Function
1, 3	NC	No connection or tied to ground
2	BS	Bootstrap pin. A bootstrap capacitor is connected between the BS pin and SW pin. The voltage across the bootstrap capacitor drives the internal high-side power MOSFET
4	IN	Supply input pin. A capacitor should be connected between the IN pin and GND pin to keep the input voltage constant
5	SW	Power switch output pin. This pin is connected to the inductor and bootstrap capacitor
6	GND	Ground pin
7	FB	Feedback pin. This pin is connected to an external resistor divider to program the system output voltage. When the FB pin voltage exceeds 20% of the nominal regulation value of 0.920V, the over voltage protection is triggered. When the FB pin voltage is below 0.6V, the oscillator frequency is lowered to realize short circuit protection
8	COMP	Compensation pin. This pin is the output of the transconductance error amplifier and the input to the current comparator. It is used to compensate the control loop. Connect a series RC network from this pin to GND. In some cases, an additional capacitor from this pin to GND pin is required
9	EN	Control input pin. Forcing this pin above 1.5V or set this pin floating enables the IC. Forcing this pin below 0.5V shuts down the IC. When the IC is in shutdown mode, all functions are disabled to decrease the supply current below 1 μ A
10	SS	Soft-start control input pin. SS controls the soft start period. Connect a capacitor from SS to GND to set the soft-start period. A 0.1 μ F capacitor sets the soft-start period to 10ms. To disable the soft-start feature, leave SS unconnected

**380kHz, 2A Asynchronous DC-DC Buck Converter****AP3201A****Absolute Maximum Ratings (Note 1)**

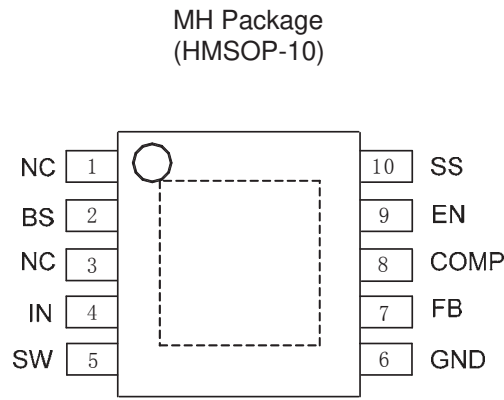
Parameter	Symbol	Value	Unit
IN Pin Voltage	V_{IN}	-0.3 to 20	V
EN Pin Voltage	V_{EN}	-0.3 to V_{IN}	V
SW Pin Voltage	V_{SW}	20	V
BS Pin Voltage	V_{BS}	-0.3 to $V_{SW}+6$	V
FB Pin Voltage	V_{FB}	-0.3 to 6	V
COMP Pin Voltage	V_{COMP}	-0.3 to 6	V
SS Pin Voltage	V_{SS}	-0.3 to 6	V
Thermal Resistance	θ_{JA}	60	°C/W
Operating Junction Temperature	T_J	150	°C
Storage Temperature	T_{STG}	-65 to 150	°C
Lead Temperature (Soldering, 10sec)	T_{LEAD}	260	°C
ESD (Machine Model)		200	V
ESD (Human Body Model)		2000	V

Note 1: Stresses greater than those listed under “Absolute Maximum Ratings” may cause permanent damage to the device. These are stress ratings only, and functional operation of the device at these or any other conditions beyond those indicated under “Recommended Operating Conditions” is not implied. Exposure to “Absolute Maximum Ratings” for extended periods may affect device reliability.

Recommended Operating Conditions

Parameter	Symbol	Min	Max	Unit
Input Voltage	V_{IN}	4.75	18	V
Maximum Output Current	$I_{OUT(Max)}$	2		A
Operating Ambient Temperature	T_A	-40	85	°C

**380kHz, 2A Asynchronous DC-DC Buck Converter****AP3201A****Electrical Characteristics**

$V_{IN}=V_{EN}=12V$, $V_{OUT}=3.3V$, unless otherwise specified. Specification with standard typeface are for $T_A=25^\circ C$, and those in **boldface type** apply over the full operating temperature range ($T_A=-40^\circ C$ to $85^\circ C$)

Parameter	Symbol	Conditions	Min	Typ	Max	Unit
Input Voltage	V_{IN}		4.75		18	V
Quiescent Current	I_Q	$V_{FB}=1.0V$, $V_{EN}=2V$		1.0	1.5	mA
Shutdown Supply Current	I_{SHDN}	$V_{EN}=0V$		1	10	μA
Feedback Voltage	V_{FB}		0.902	0.920	0.938	V
Feedback Over Voltage Threshold	V_{FBOV}			1.1		V
Feedback SCP Voltage Threshold	V_{FBSCP}			0.6		V
Feedback Bias Current	I_{FB}	$V_{FB}=1V$	-0.1		0.1	μA
High-side Switch On-resistance (Note 2)	R_{DSONH}	$I_{SW}=0.5A$		0.22		Ω
Low-side Switch On-resistance (Note 2)	R_{DSONL}	$I_{SW}=0.05A$		10		Ω
High-side Switch Leakage Current	I_{LEAKH}	$V_{IN}=18V$, $V_{EN}=0V$ $V_{SW}=0V$		0.1	10	μA
High-side Switch Current Limit	I_{LIMH}		2.8	3.8		A
Low-side Switch Current Limit	I_{LIML}	From drain to source		0.15		A
EN Pin Threshold	V_{ENH}		1.5			V
	V_{ENL}				0.5	
EN Pull-up Current	I_{EN-PH}	$V_{EN}=0V$		1.0		μA
Input UVLO Threshold	V_{UVLO}	V_{IN} Rising	3.5	3.9	4.4	V
Input UVLO Hysteresis	V_{HYS}			0.3		V
Oscillator Frequency	F_{OSC1}			380		kHz
Short Circuit Oscillator Frequency	F_{OSC2}			90		kHz
Maximum Duty Cycle	D_{MAX}	$V_{FB}=0.8V$		90		%
Minimum Duty Cycle	D_{MIN}	$V_{FB}=1.0V$			0	%
Error Amplifier Voltage Gain (Note 3)	A_{EA}			400		V/V
Error Amplifier Transconductance	G_{EA}			700		$\mu A/V$
COMP to Current Sense Transconductance	G_{CS}			2.4		A/V
Thermal Shutdown (Note 3)	T_{OTSD}			160		$^\circ C$
Thermal Shutdown Hysteresis (Note 3)	T_{HYS}			30		$^\circ C$
Soft-start Time (Note 3)	t_{SS}	$I_{OUT}=500mA$ $C_{SS}=0.1\mu F$		10		ms
Soft-start Current	I_{SS}			6		μA



380kHz, 2A Asynchronous DC-DC Buck Converter

AP3201A

Note 2: $R_{\text{DSON}} = \frac{V_{\text{SW1}} - V_{\text{SW2}}}{I_{\text{SW1}} - I_{\text{SW2}}}$

Note 3: Not tested, guaranteed by design.

Typical Performance Characteristics

$T_A = 25^\circ\text{C}$, $V_{\text{IN}} = 12\text{V}$, $V_{\text{OUT}} = 3.3\text{V}$, unless otherwise noted.

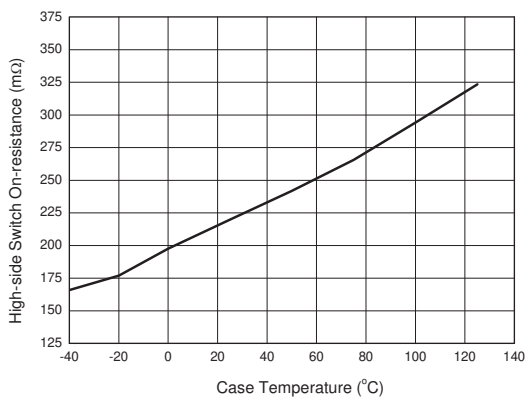

Figure 4. High-side Switch On-resistance vs. Case Temperature

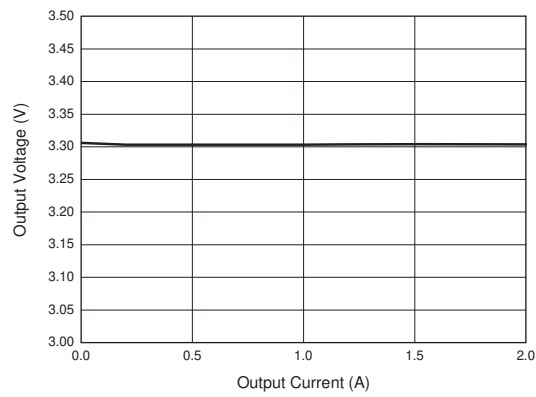

Figure 5. Output Voltage vs. Output Current

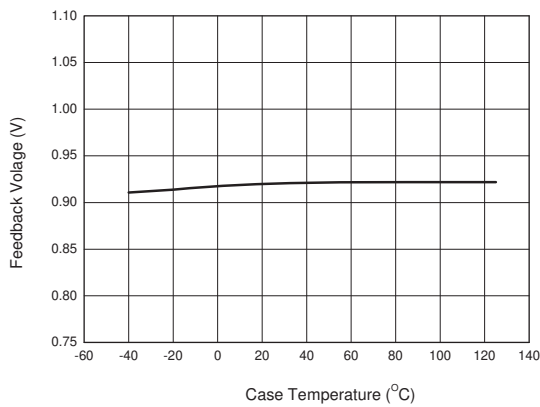

Figure 6. Feedback Voltage vs. Case Temperature

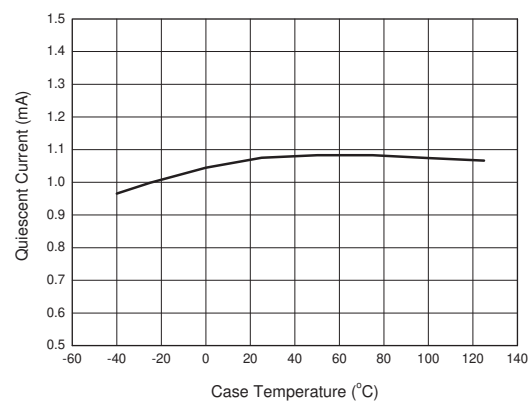

Figure 7. Quiescent Current vs. Case Temperature



380kHz, 2A Asynchronous DC-DC Buck Converter

AP3201A

Typical Performance Characteristics (Continued)

$T_A=25^\circ\text{C}$, $V_{IN}=12\text{V}$, $V_{OUT}=3.3\text{V}$, unless otherwise noted.

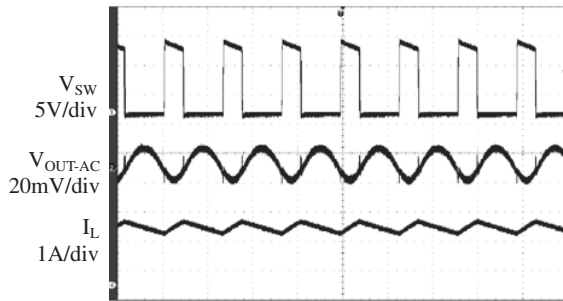

Time (2µs/div)

Figure 8. Output Ripple ($I_{OUT}=2\text{A}$)

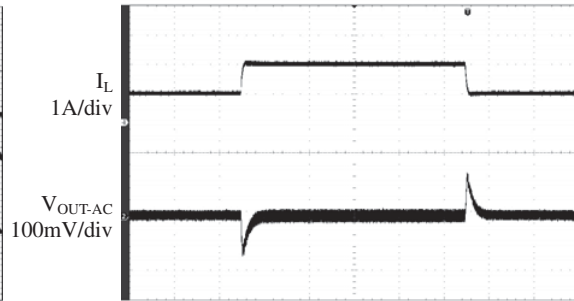

Time (200µs/div)

Figure 9. Load Transient ($I_{OUT}=1$ to 2A)

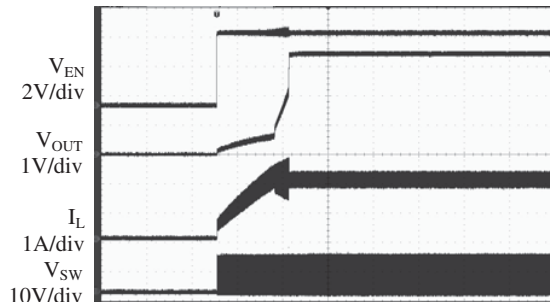

Time (10ms/div)

Figure 10. Enable Turn on Characteristic ($I_{OUT}=2\text{A}$, CC Mode)

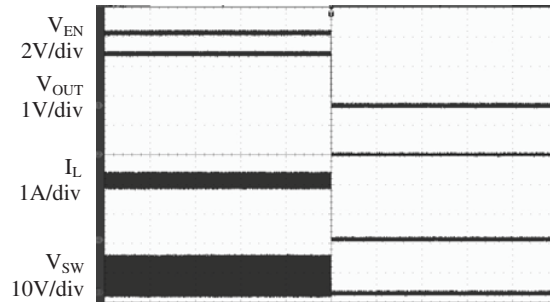

Time (10ms/div)

Figure 11. Enable Turn off Characteristic ($I_{OUT}=2\text{A}$, CC Mode)



Typical Performance Characteristics (Continued)

$T_A=25^\circ\text{C}$, $V_{IN}=12\text{V}$, $V_{OUT}=3.3\text{V}$, unless otherwise noted.

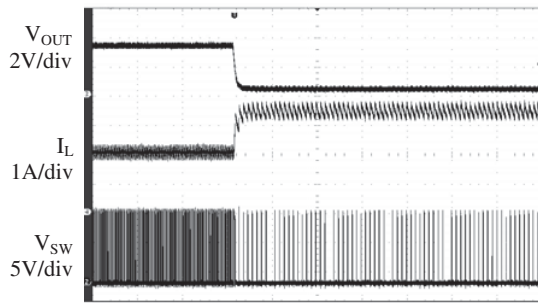

Time (100 $\mu\text{s}/\text{div}$)

Figure 12. Short Circuit Protection
($I_{OUT}=2\text{A}$)

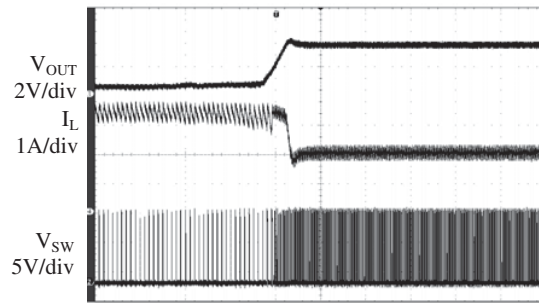

Time (100 $\mu\text{s}/\text{div}$)

Figure 13. Short Circuit Recovery
($I_{OUT}=2\text{A}$)

Typical Application

Figure 14. Typical Application of AP3201A



BCD Semiconductor Manufacturing Limited

<http://www.bcdsemi.com>

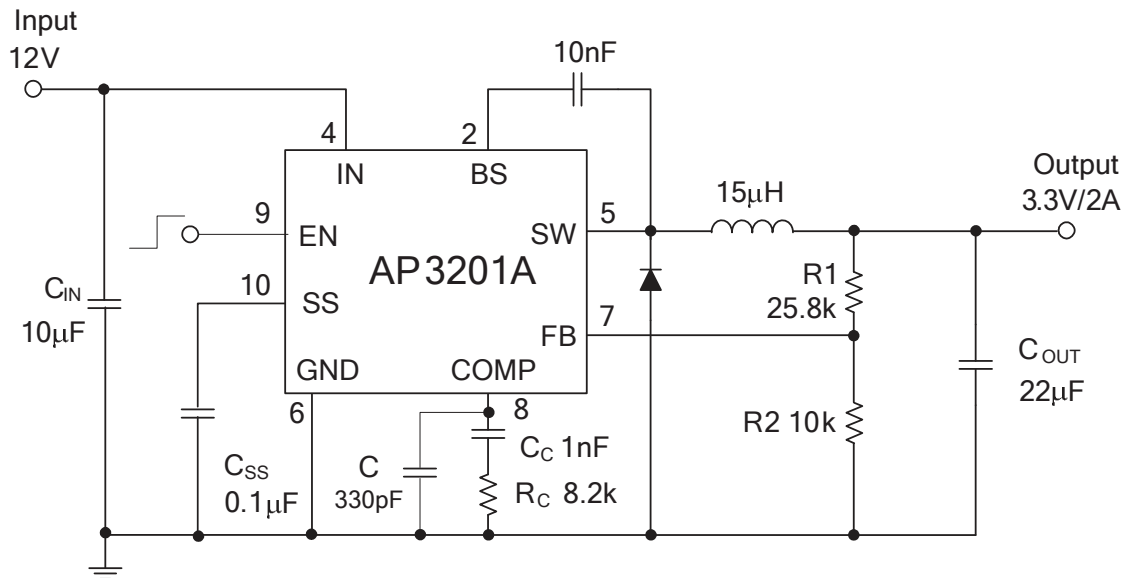
IMPORTANT NOTICE

BCD Semiconductor Manufacturing Limited reserves the right to make changes without further notice to any products or specifications herein. BCD Semiconductor Manufacturing Limited does not assume any responsibility for use of any its products for any particular purpose, nor does BCD Semiconductor Manufacturing Limited assume any liability arising out of the application or use of any its products or circuits. BCD Semiconductor Manufacturing Limited does not convey any license under its patent rights or other rights nor the rights of others.

MAIN SITE

- Headquarters
BCD Semiconductor Manufacturing Limited
No. 1600, Zi Xing Road, Shanghai Zizhu Science-based Industrial Park, 200241, China
Tel: +86-21-24162266, Fax: +86-21-24162277

- Wafer Fab
Shanghai SIM-BCD Semiconductor Manufacturing Co., Ltd.
800 Yi Shan Road, Shanghai 200233, China
Tel: +86-21-6485 1491, Fax: +86-21-5450 0008

REGIONAL SALES OFFICE

Shenzhen Office
Shanghai SIM-BCD Semiconductor Manufacturing Co., Ltd., Shenzhen Office
Unit A Room 1203, Skyworth Bldg., Gaoxin Ave.1.S., Nanshan District, Shenzhen, China
Tel: +86-755-8826 7951
Fax: +86-755-8826 7865

Taiwan Office
BCD Semiconductor (Taiwan) Company Limited
4F, 298-1, Rui Guang Road, Nei-Hu District, Taipei, Taiwan
Tel: +886-2-2656 2808
Fax: +886-2-2656 2806

USA Office
BCD Semiconductor Corp.
30920 Huntwood Ave. Hayward, CA 94544, USA
Tel: +1-510-324-2988
Fax: +1-510-324-2788