



Features

- Transformer signal coupling
- Complete ring detector circuit
- Low power hookswitch
- Electronic inductor/gyrator circuit
- Surge protection
- Caller ID pinout to external relay (optional)
- Transient protection zeners
- V.32 compatible
- FCC Compatible
- PC board mountable
- Parallel telephone off-hook detection

Description

The CYG2911 is a Data Access Arrangement (DAA) module providing a complete telephone line interface circuit in a small 1.07" x 1.07" x 0.4" plastic package. This module incorporates a circuit which signals HIGH when another phone in parallel has been taken off-hook when the CYG2911 is off-hook. This feature is important for cable TV set-top boxes and direct broadcast satellite units which must hang-up (go on-hook) when a consumer needs the phone line to place a 911 or emergency call. The module is designed to meet FCC Part 68 requirements thus providing a low-risk design solution.

Applications

- Home medical devices
- Plant monitoring equipment
- Security/alarm systems
- Utility meters
- Network routers
- PBX systems
- Telephony applications
- Set top boxes

Approvals

- UL 1950/UL1459
- Compatible with U.S. and Canadian phone lines

Ordering Information

Part #	Description
CYG2911	DAA Module

Block Diagram

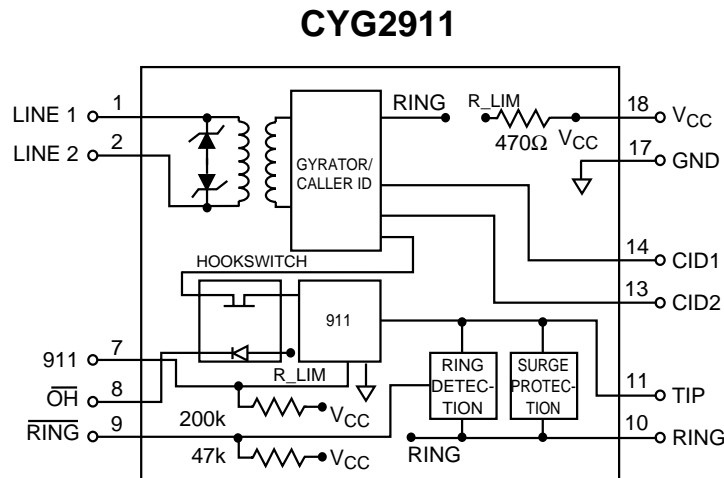

Handling and Assembly Recommendations

The CYG2911 products are not hermetically sealed and should not be exposed to any liquid-based rinsing processes. Clare recommends two (2) approaches. The modem should either use a no clean soldering flux that would mostly evaporate during the normal wave soldering processes, or be soldered in by hand after the rest of the card is wave soldered.

Absolute Maximum Ratings (@ 25° C)

Parameter	Min	Typ	Max	Units
Isolation Voltage	-		1000	V _{RMS}
Operational Temperature	0		+70	°C
Storage Temperature	0	-	+100	°C
Relative Humidity (Non-Condensing)	10	-	85	%
Soldering Temperature	-	-	+260	°C
Tip/Ring (5, 6) Load Current (continuous)	-	-	120	mA
Hookswitch LED Drive Current	-	-	50	mA
Hookswitch LED Reverse Voltage	-	-	5	V
Ring Detect Phototransistor Voltage V _{CC}	-	-	20	V

Absolute Maximum Ratings are stress ratings. Stresses in excess of these ratings can cause permanent damage to the device. Functional operation of the device at these or any other conditions beyond those indicated in the operational sections of this data sheet is not implied. Exposure of the device to the absolute maximum ratings for an extended period may degrade the device and effect its reliability.

Electrical Characteristics

Parameter	Conditions	Min	Typ	Max	Unit
DC Electrical Characteristics					
On-Hook Impedance	@100VDC across pins 10,11 (R,T), per FCC 68.312	10	-	-	MΩ
Off-Hook Line Leakage Current	@100VDC across pins 10,11 (R,T), per FCC 68.312	-	-	10	μA
Hookswitch Resistance	-	-	-	15	Ω
Off-Hook Supply Current	@+5V, V _{CC}	7	8	9	mA
Hookswitch Power Source, Pin 8	-	4.75	5.0	20	V
DC Loop Current	-	20	-	120	mA
AC Signal Path Electrical Characteristics					
Return Loss	300-3500Hz	18	25	-	dB
Insertion Loss					
Transmit	Test Circuit 1	-	-	9	dB
Receive	Test Circuit 2	-	-	9	dB
Frequency Response	300-3500Hz	-0.25	-	+0.25	dB
Longitudinal Balance					
On-Hook	Per FCC 68.310	60	-	-	dB
Off-Hook	Per FCC 68.310	40	-	-	dB
DC Loop Current	-	20	-	120	mA
Total Harmonic Distortion + N	@600Hz and -10dBm	-	-45	-	dBm
Secondary Load Impedance	Line 1 and Line 2	-	294	-	Ω
Primary Source Impedance	Tip and Ring	-	600	-	Ω
Ring Detection Circuit Characteristics					
Ringing Voltage Detection Range	-	20	-	150	V _{RMS}
Ringing Frequency Detection Range	-	15	-	70	Hz
Ringer Equivalence Number	-	-	0.8B	-	
RING (Pin 9) Output Voltage (Pulsed)	V _{CC} @+5V				
Logic '0', Ring present	-	-	-	0.8	V
Logic '1', Ring not present	-	-	-	V _{CC}	V
Surge, Transient, and Isolation Characteristics					
Surge Protection Voltage Tip and Ring (Pins 11,10)	-	-	-	300	
Transient Voltage Protection on Line 1 and Line 2 (Pins 1,2)	-	-5	-	+5	V
Isolation Voltage (Pins 1,2,7,8,9,17,18 to 10,11,13,14)	Per FCC 68.302	-	-	1000	V _{RMS}

Electrical Characteristics (Continued)

Parameter	Conditions	Min	Typ	Max	Unit
911 Detection Characteristics (Pin 7)					
Pulse Voltage					
External phone off-hook	-	2.4	-	V_{CC}	V
External phone on-hook	-	-	-	0.8	V
Pulse Width	Telephone DCR 200 Ω	20	40	60	mS
Internal pull-up resistor	-	-	200K	-	Ω

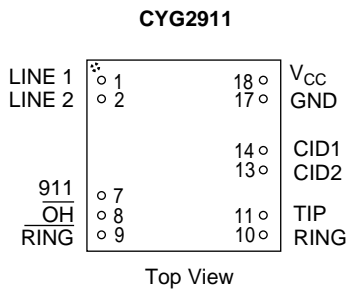
Package Pinout

CYG2911 Pinouts & Definitions

PIN#	I/O	Name	Function
1	I/O	LINE1	Transformer isolated audio signal coupling path for the telephone line.
2	I/O	LINE2	Transformer isolated audio signal coupling path for the telephone line.
7	O	911	Signals HIGH for 20-60ms when the CYG2911 is off-hook and another phone goes off-hook. Glitches may appear on this pin when the CYG2911 first goes off-hook, and should be ignored for a minimum of 200ms.
8	I	OH	Driving this pin LOW asserts the off-hook condition. The hookswitch LED is current limited by an internal 470 Ω resistor.
9	O	RING	Active LOW indicates an incoming ring signal. This is pulsed LOW by the AC ring signal at the ring frequency from 15-40Hz.
10	I/O	RING	Connection to telephone line Ring conductor.
11	I/O	TIP	Connection to telephone line Tip conductor.
13	O	CID2	Caller ID connection. CID1/CID2 connect to an external 1-Form-A solid state relay (Clare LCA110). When the SSR is closed (connecting CID1 to CID2), Caller ID information is presented to LINE1/LINE2 after the first telephone ring burst.
14	O	CID1	Caller ID connection. See CID2 above.
17	I	GND	Connected to host system ground.
18	I	V_{CC}	Provides power to the hookswitch LED. Typically +5V for \approx 8mA LED current. LED is current limited by an internal 470 Ω resistor. V_{CC} should not exceed 20V.

CYG2911
Caller ID Connections

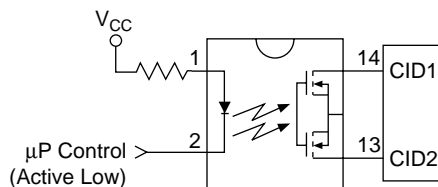
Pins 13 & 14 should be connected to a 1-Form-A relay (Clare LCA110), as follows:





CLARE

For additional information please visit our website at: www.clare.com

Clare, Inc. makes no representations or warranties with respect to the accuracy or completeness of the contents of this publication and reserves the right to make changes to specifications and product descriptions at any time without notice. Neither circuit patent licenses nor indemnity are expressed or implied. Except as set forth in Clare's Standard Terms and Conditions of Sale, Clare, Inc. assumes no liability whatsoever, and disclaims any express or implied warranty, relating to its products including, but not limited to, the implied warranty of merchantability, fitness for a particular purpose, or infringement of any intellectual property right.

The products described in this document are not designed, intended, authorized or warranted for use as components in systems intended for surgical implant into the body, or in other applications intended to support or sustain life, or where malfunction of Clare's product may result in direct physical harm, injury, or death to a person or severe property or environmental damage. Clare, Inc. reserves the right to discontinue or make changes to its products at any time without notice.

Specification: DS-CYG2911-R1.0
©Copyright 2002, Clare, Inc.
All rights reserved. Printed in USA.
6/25/02