

ADVANCE INFORMATION

All information in this data sheet is preliminary and subject to change.

8/97



Low-Power, Dual, 13-Bit Voltage-Output DACs with Configurable Output

General Description

The MAX5152/MAX5153 low-power, serial, voltage-output, dual, 13-bit digital-to-analog converters (DACs) consume only 500µA from a single +5V (MAX5152) or +3V (MAX5153) supply. These devices feature Rail-to-Rail® output swing and are available in a space-saving 16-pin QSOP package. Access to the output amplifier's inverting input allows for specific gain configurations, remote sensing, and high output current capability, making these devices ideal for industrial process controls. They are also well suited for digitally programmable, 4-20mA current loops.

The 3-wire serial interface is SPI™/QSPI™ and Microwire™ compatible. Each DAC has a double-buffered input organized as an input register followed by a DAC register, which allows the input and DAC registers to be updated independently or simultaneously. Additional features include a 2µA programmable shutdown, a hardware-shutdown lockout, a separate voltage reference input for each DAC that accepts AC and DC signals, and an active-low clear input (CL) that resets all registers and DACs to zero. These devices provide a programmable logic pin for added functionality and a serial-data output pin for daisy-chaining.

Applications

Industrial Process Control Motion Control
 Digital Offset and Gain Remote Industrial Controls
 Adjustment µP-Controlled Systems
 Digitally Programmable, Automatic Test Equipment
 4-20mA Current Loops

Features

- ◆ 13-Bit Dual DAC with Configurable Output Amplifiers
- ◆ Rail-to-Rail Output Swing
- ◆ 16µs Settling Time
- ◆ Single-Supply Operation: +5V (MAX5152)
+3V (MAX5153)
- ◆ Low Quiescent Current: 500µA (normal operation)
2µA (shutdown mode)
- ◆ SPI/QSPI and Microwire Compatible
- ◆ Space-Saving 16-Pin QSOP Package
- ◆ Power-On Reset Clears DAC Outputs to Zero

Ordering Information

PART	TEMP. RANGE	PIN-PACKAGE	INL (LSB)
MAX5152ACPE	0°C to +70°C	16 Plastic DIP	±1/2
MAX5152BCPE	0°C to +70°C	16 Plastic DIP	±1
MAX5152ACEE	0°C to +70°C	16 QSOP	±1/2
MAX5152BCPE	0°C to +70°C	16 QSOP	±1
MAX5152BC/D	0°C to +70°C	Dice*	±1

Ordering Information continued on next page.
 *Dice are tested at T_A = +25°C, DC parameters only.

Functional Diagram

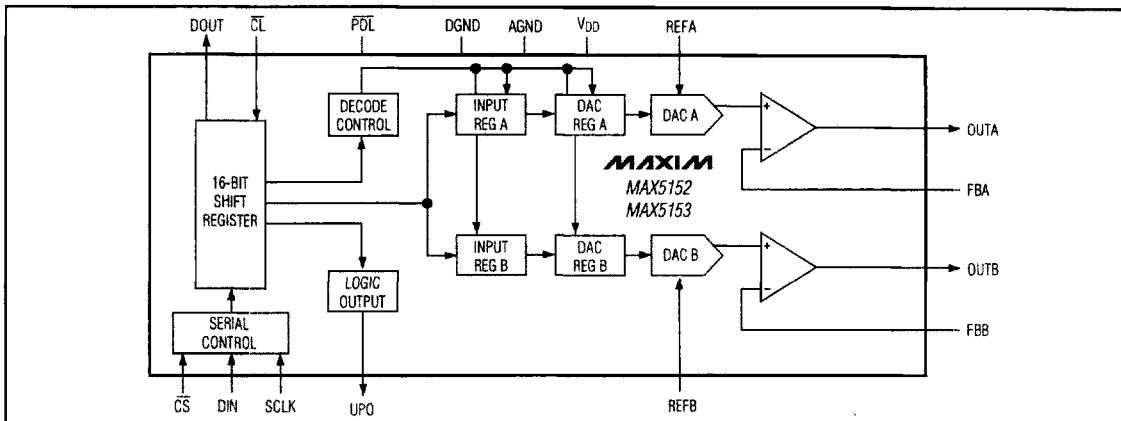

Rail-to-Rail is a registered trademark of Nippon Motorola Ltd. Microwire is a trademark of National Semiconductor Corp. SPI and QSPI are trademarks of Motorola, Inc.



Maxim Integrated Products 9-101

For free samples & the latest literature: <http://www.maxim-ic.com>, or phone 1-800-998-8800
 For small orders, phone 408-737-7600 ext. 3468.

MAX5152/MAX5153

Low-Power, Dual, 13-Bit Voltage-Output DACs with Configurable Output

Ordering Information (continued)

PART	TEMP. RANGE	PIN-PACKAGE	INL (LSB)
MAX5152AEPE	-40°C to +85°C	16 Plastic DIP	±1/2
MAX5152BEPE	-40°C to +85°C	16 Plastic DIP	±1
MAX5152AESEE	-40°C to +85°C	16 QSOP	±1/2
MAX5152BEEE	-40°C to +85°C	16 QSOP	+1
MAX5152BMJE	-55°C to +125°C	16 CERDIP	±1
MAX5153 ACPE	0°C to +70°C	16 Plastic DIP	±1
MAX5153BCPE	0°C to +70°C	16 Plastic DIP	±2
MAX5153ACEE	0°C to +70°C	16 QSOP	±1
MAX5153BCPE	0°C to +70°C	16 QSOP	±2
MAX5153BC/D	0°C to +70°C	Dice*	±2
MAX5153AEPE	-40°C to +85°C	16 Plastic DIP	±1
MAX5153BEPE	-40°C to +85°C	16 Plastic DIP	±2
MAX5153AESEE	-40°C to +85°C	16 QSOP	±1
MAX5153BEEE	-40°C to +85°C	16 QSOP	±2
MAX5153BMJE	-55°C to +125°C	16 CERDIP	±2

*Dice are tested at $T_A = +25^\circ\text{C}$, DC parameters only.

Pin Configuration

